

# **Monitoring report**

**Version 01**

**28MW Jinkouba Hydropower Project**  
**(CDM Registration Reference Number: 1633)**

**Monitoring Period: 18/02/2009-26/02/2010**

**Date: 31/03/2010**

## **1. Introduction**

This document reports the emission reductions generated by 28MW Jinkouba Hydropower Project (hereafter refers to “JHP” or “the project”) during the following period (including start and end days):

**18/02/2009 – 26/02/2010**

The Project Design Document (PDD) of the project activity was registered as a CDM project on February 18<sup>th</sup> 2009 with UNFCCC Registration Reference Number 1633.

This monitoring report has been prepared in accordance with the monitoring plan contained in the registered PDD and will serve as the basis for verification, certification and issuance of the emission reductions during the monitoring period indicated above.

## **2. Project implementation in relation to registered PDD**

### **2.1 Description of the project activity**

The 28MW Jinkouba Hydropower Project, a run-of-river hydropower project, is located on Baishuijiang River in Gansu Province, China. The total installed capacity of JHP is 28 MW, provided by two 14MW turbines, with an annual net output of 127,900MWh. Generated electricity will be exported to Northwest Region Power Grid (“NWPG”) through Gansu Grid to displace part of the electricity generated by fuel fired power plants, and thus reduce CO<sub>2</sub> emissions from thermal power plants. The estimated annual GHG emission reductions are 108,689 tCO<sub>2</sub>e.

The project is operated by Jintai Hydropower Co. Ltd of Wen County in Gansu Province (hereinafter referred as “the Company” or “JHCL”).

### **2.2 Project location**

The project is located on the Baishuijiang River in Wen County, south of Gansu Province. The pivotal project is located in the Jinkouba village, 28 kilometres away from Wen County seat, and 750 km away from Lanzhou City (capital of Gansu province). JHP has geographical with the north latitude of 32°50'52" and east longitude of 104°53'18". Detailed information please refers to the PDD of the project.

### **2.3 Operation of the project**

#### **◆ Current Status**

After more than two years’ construction, including a sand washing sluice, a flood discharge sluice, a gravity dam, an open ditch, a tunnel, a forebay, a penstock, a powerhouse, a tail water ditch and a booster station etc., the project with an installed capacity of 28MW became operational on 1<sup>st</sup> Feb 2008. During the first monitoring period, JHP operates smoothly.

#### **◆ Project performance**

The project is expected to supply electricity 127,900MWh to the grid annually. In the first monitoring period the actual generation is 136287.348MWh.

#### **◆ Emergencies**

During the monitoring period there have been no occurrences of emergencies.

#### **◆ Corrective actions**

During the operation of the project activity during the monitoring period there have been no

events that required corrective actions.

### 3. Monitoring methodology

The project activity uses the approved consolidated baseline methodology ACM0002 (Version 6): “Consolidated baseline methodology for grid-connected electricity generation from renewable sources” and the approved consolidated monitoring methodology: “Consolidated monitoring methodology for zero-emissions grid-connected electricity generation from renewable sources”. For more information regarding the baseline methodology and monitoring methodology, please refer to:

[http://cdm.unfccc.int/UserManagement/FileStorage/CDMWF\\_AM\\_BW759ID58ST5YEEV6WUCN5744MN763](http://cdm.unfccc.int/UserManagement/FileStorage/CDMWF_AM_BW759ID58ST5YEEV6WUCN5744MN763)

### 4. Monitoring plan

Monitoring Plan for this project has been developed to ensure that the project is well operation and management in terms of the collection and archiving of complete and reliable data. Monitoring plan includes the management and implementation structures of monitoring activity, data collection procedures, parameter to be monitored and quality control process. JHP has implemented an operational and management structure in order to monitor and record emission reductions accurately. The control centre provides the operation reports of the project activity. The project’s operation and monitoring manual including responsibilities and authorities for project management, procedures for monitoring and reporting, QA/QC procedures, procedures for calibration of metering equipment and procedures for training and maintenance.

#### 4.1 Operational and Management Structure

In order to operate and manage the CDM project activities, the project entity-JHCL had constituted detailed rules on CDM project management, the special CDM project manager authorized by the project entity will be in charge of all the management works, training and the fulfillment of the Monitoring Plan. There set up a CDM project team comprised of five persons, the team assigns qualified persons to measure, compile and archive the necessary data of monitoring plan. Detailed structure as follows:

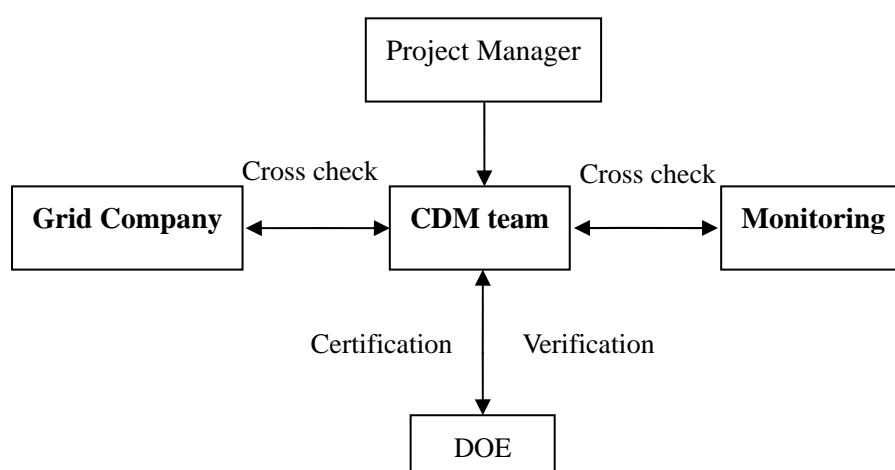

#### 4.2 Parameters to be monitored

Data/Parameters	Electricity Exports (EG <sub>Ex</sub> )
-----------------	---

Data Unit	MWh
Description	Annual electricity supplied to the NWPG by the project
Source of data to be used	Records of meter according to monitoring plan
Description of measurement methods and procedures to be applied	Electricity will be measured directly and continuously by computed and precise ammeters. Recording frequency will be hourly measurement and monthly recording; Proportion of data to be monitored would be 100% throughout whole year; The data will be archived both in electronic and paper; Data monitored are to be kept for two years after the last issuance of CERs for the project.
QA/QC procedures to be applied	Set up a special CDM project team; Constitute detailed rules on monitoring management; Introduce precision ammeters; Two ammeters were proofread each other both in booster station and substation; To calibrate the meters periodically in accordance with related measure standard in China. The meter(s) will be read frequently jointly by the project developer and the grid company. Keep the invoice of electricity sales as a hard proof for data quality control etc.

Data/Parameters	Electricity Imports ( $EG_{Im}$ )
Data Unit	MWh
Description	Annual electricity imported to the project from the NWPG
Source of data to be used	Records of meter according to monitoring plan
Description of measurement methods and procedures to be applied	The similar measurement methods and procedures as electricity exports.
QA/QC procedures to be applied	The meter(s) will be read frequently jointly by the project developer and the grid company. Keep the invoice of electricity purchase as a hard proof for data quality control.

Data/Parameters	Net Electricity Exports ( $EG_y$ )
Data Unit	MWh
Description	Net electricity supplied to the NWPG by the project in year y.
Source of data to be used	Subtract electricity imports ( $EG_{Im}$ ) from electricity exports ( $EG_{Ex}$ ), viz. $EG_y = EG_{Ex} - EG_{Im}$
Description of measurement methods and procedures to be applied	To monitor electricity exports and electricity imports with bidirectional meters synchronously, calculated through subtracting electricity imports from electricity exports by the CDM team of the project.
QA/QC procedures to be applied	Directed and inspected by CDM project team leader, calculated and finished by monitoring charge and monitoring person, keep all original recorders for verification.

### 4.3 Calibration of Meters

In accordance with the registered PDD, calibration is carried out annually by Gansu Electric Power Company (GEPC), then lead seals to ensure the accuracy and impartiality of the meters. Before the project operates formally, calibration of meters was carried out by GEPC. Calibration tests records will be maintained for verification.

## 4.4 Monitoring systems and procedures

### 4.4.1 Metering of the electricity delivered to the grid and imported electricity

The electricity delivered to the grid is the key data needed for monitoring. The monthly electricity delivered to the grid by the project and import electricity by it are monitored on the interface between Jinkouba hydropower station and the grid by automatic monitoring equipment by Gansu Electric Power Company and the project entity mutually.

- According to the requirements in metering of Gansu Electric Power Company, two-way meters and control equipments will be installed in the substation and the power plant respectively. The accuracy of meters is 0.2s.
- The electricity delivered to the grid by the project and imported electricity of the project is mainly based on the monitoring data coming from the main meter (M2) installed at 110kV Yulei Transformer Substation which monitored regularly by Gansu Electric Power Company. And the data is measured hourly, recorded monthly and archived both electronically. Every month the designated staff of Longnan Electric Power Company, a subsidiary company of Gansu Electric Power Company and the project entity jointly record the main meter (M2). At 24:00 of the third day from end of each month, the grid company reads the main meter (M2) and supplies readings to the project entity. Upon this, the monthly power purchase settlement notice is prepared and the sales invoice is issued based on it.
- To ensure maximum availability of monitoring data and quality controls of the CDM data, the backup (auxiliary) meter (M1) was installed at 10.5kV Jinkouba Booster Station. At the station site, the project entity read the meter (M1) every hour and record data every month. Furthermore, the records would be kept in electronic form, and monthly generation data would be printed out for a back up for the improbable event of a computer hazard.

The detailed metering figure was shown below:

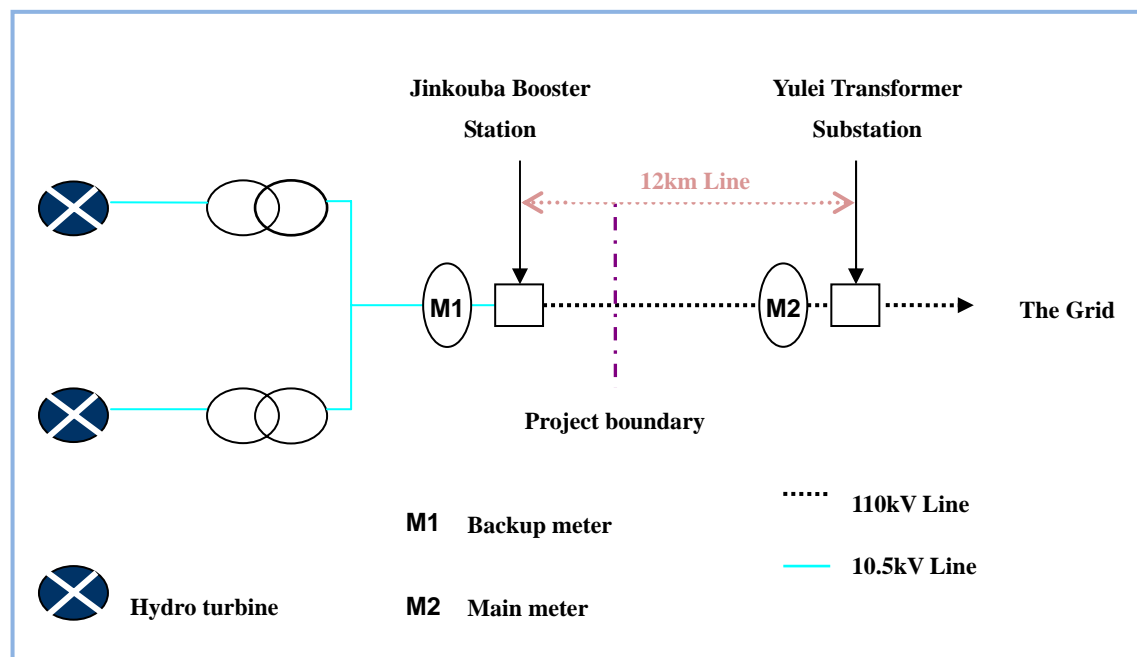

#### 4.4.2 Quality Assurance (QA) and Quality Control (QC)

The quality assurance and quality control procedures for reading, maintaining and archiving data shall be improved as part of this CDM project activity. In order to ensure the accuracy and rationality of metering data, the CDM project team will take charge of the audit tasks. All the records (include the electronic files, paper documents, maintenance and calibration data etc.), should be reported to the team, so as to judge whether there is bias on plant operation and ensure the on-going process through the defined crediting period in terms of the need for verification on an annual basis. At the same time, the metering data by the plant can be cross-checked with the Electricity Sales Invoices issued by Electricity Power Company. In addition, the data required for the calculations of reduce emission for verification, should mainly based on the metering data by the substation, and secondary to the data metered by the power plant.

### 5. Calculation of emission reductions

#### 5.1 Emission factors

According to baseline methodology, baseline emission factor  $EF_y$  is calculated as the weighted average of the Operating Margin emission factor ( $EF_{OM,y}$ ) and the Build Margin emission factor ( $EF_{BM,y}$ ):

$$EF_y = 0.5 \times EF_{OM,y} + 0.5 \times EF_{BM,y} = 0.8498 \text{ tCO}_2/\text{MWh}$$

Table3: calculation of baseline emission factor  $EF_y$

Emission factor	Operating Margin emission factor ( $EF_{OM,y}$ )	Build Margin emission factor ( $EF_{BM,y}$ )	Baseline emission factor $EF_y$
Unit	tCO <sub>2</sub> /MWh	tCO <sub>2</sub> /MWh	tCO <sub>2</sub> /MWh
Data	1.1257	0.5739	0.8498

The emission factor was determined ex-ante in the registered PDD and is fixed for the whole crediting period.

#### 5.2 Emission reductions calculation equation

According to the methodology ACM0002:  $ER_y = BE_y - PE_y - Ly$

The JHP is a run-of-river hydropower project, the GHG emissions by sources from the project equal to zero, then  $PE_y = 0$ .

The JHP is a grid-connected renewable project, referring to the description in methodology ACM0002, there no leakage, then  $Ly = 0$ .

The emission reduction  $ER_y$  by the project activity during a given year  $y$  is calculated as follows:

$$ER_y = BE_y - PE_y - Ly = EG_y \times EF_y$$

Where:

$BE_y$  —Baseline emissions of China Northwest Power Grid in year  $y$

$EG_y$  —Net electricity supplied by the project to the grid in year  $y$ .

$EF_y$  —Emission factor in year  $y$ . From the PDD, it is calculated that  $EF_y = 0.8498 \text{ tCO}_2/\text{MWh}$

#### 5.3 Net electricity supply and Emission reductions

According to the data available from GEPC and the project entity, during the 1<sup>st</sup> monitoring period, the electricity supplied to the grid by the project is 136287.348 MWh, the

imported electricity is 0 MWh. The net electricity supplied to the grid by the project is 136287.348 MWh.

Emission reductions generated in the 1<sup>st</sup> monitoring period is: 115,816 tCO<sub>2</sub>e.

monitoring period (Month)	Electricity supplied to the grid(MWh)	Electricity imported (MWh)	Net electricity supply (MWh)	ER factor (tCO <sub>2</sub> /MWh)	Emission reductions (tCO <sub>2</sub> e)
18/02/2009--26/02/2009	1390.112	0	1390.112	0.8498	1,181.32
27/02/2009--29/03/2009	4684.268	0	4684.268	0.8498	3,980.69
30/03/2009--28/04/2009	9295.744	0	9295.744	0.8498	7,899.52
29/04/2009--29/05/2009	17260.980	0	17260.980	0.8498	14,668.38
30/05/2009--28/06/2009	13687.608	0	13687.608	0.8498	11,631.73
29/06/2009--29/07/2009	10386.552	0	10386.552	0.8498	8,826.49
30/07/2009--29/08/2009	14931.048	0	14931.048	0.8498	12,688.40
30/08/2009--28/09/2009	14641.176	0	14641.176	0.8498	12,442.07
29/09/2009--29/10/2009	17513.760	0	17513.760	0.8498	14,883.19
30/10/2009--28/11/2009	12166.968	0	12166.968	0.8498	10,339.49
29/11/2009--29/12/2009	8687.920	0	8687.920	0.8498	7,382.99
30/12/2009--29/01/2010	6801.828	0	6801.828	0.8498	5,780.19
30/01/2010--26/02/2010	4839.384	0	4839.384	0.8498	4,112.51
<b>Total</b>	<b>136287.348</b>	<b>0</b>	<b>136287.348</b>	<b>0.8498</b>	<b>115,816</b>

*Comment: Data come from the power purchase settlement notice to the project by GEPC and the company's invoice for sold power to the grid.*

#### **5.4 Comparison of the actual emission reductions with the estimated in the registered PDD**

According to the registered PDD of the project, the estimated annual emission reductions are 108,689 tCO<sub>2</sub>e. This monitoring period covers 18/02/2009-26/02/2010 which is 374 days in total. Then the estimated emission reductions for this monitoring period should be:

$$108,689/365*374=111,369 \text{ tCO}_2\text{e}$$

The actual emission reductions of this monitoring period (115,816 tCO<sub>2</sub>e) is larger than the estimation (111,369 tCO<sub>2</sub>e) in the registered PDD, which is due to the feasibility study in the PDD is based on a long term average for hydrological conditions. It is highly unlikely that the hydrological conditions in a single monitoring period are identical to the long term average.