



3.5 MW SMALL HYDRO PROJECT IN HIMACHAL PRADESH



Document Prepared by EKI Energy Services Limited

Project Title	3.5 MW Small Hydro Project In Himachal Pradesh
Version	04
Report ID	2033
Date of Issue	11-November-2022
Project ID	2033
Monitoring Period	01-September-2021 to 31-July-2022 (Both days included)
Prepared By	Bhavini Pandey
Contact	Senior Executive Operations – GHG Services EKI Energy Services Limited Email ID : registry@enkingint.org , bhavini.pandey@enkingint.org +91 9532180246 Address: Office no. 201, Plot 48, Scheme 78 part 2 Vijay Nagar, Near Brilliant Convention Centre Indore - 452010 (M.P, India) Website www.enkingint.org

CONTENTS

1	PROJECT DETAILS.....	3
1.1	Summary Description of the Implementation Status of the Project	3
1.2	Sectoral Scope and Project Type	4
1.3	Project Proponent	4
1.4	Other Entities Involved in the Project	4
1.5	Project Start Date	5
1.6	Project Crediting Period	5
1.7	Project Location	5
1.8	Title and Reference of Methodology	6
1.9	Participation under other GHG Programs	7
1.10	Other Forms of Credit.....	7
1.11	Sustainable Development Contributions	7
2	SAFEGUARDS.....	9
2.1	No Net Harm	9
2.2	Local Stakeholder Consultation	9
2.3	AFOLU-Specific Safeguards	10
3	IMPLEMENTATION STATUS.....	10
3.1	Implementation Status of the Project Activity	10
3.2	Deviations	13
3.3	Grouped Projects	13
4	DATA AND PARAMETERS.....	13
4.1	Data and Parameters Available at Validation	13
4.2	Data and Parameters Monitored.....	16
4.3	Monitoring Plan.....	22
5	QUANTIFICATION OF GHG EMISSION REDUCTIONS AND REMOVALS	25
5.1	Baseline Emissions	25
5.2	Project Emissions	26
5.3	Leakage.....	27
5.4	Net GHG Emission Reductions and Removals.....	27
	APPENDIX 1: CALIBRATION AND METER DETAILS.....	29
	APPENDIX 2: BREAKDOWN DETAILS.....	30

1 PROJECT DETAILS

1.1 Summary Description of the Implementation Status of the Project

The project activity involves generation of 3.5 MW hydro power by utilizing naturally available potential energy of water in the Sarwari nullah (tributary of river Beas) / Riavi river located in Kullu and Chamba district respectively in the state of Himachal Pradesh.

The 3.5 MW bundled small hydro project is a greenfield hydroelectric power project located in the state of Himachal Pradesh, India comprising of two hydroelectric projects – Sarwari-III Hydro Electric Project of capacity 2 MW by Gaur Hydro Power Pvt. Ltd and Siunr Hydro Electric Project of capacity 1.5 MW by Gopal Powerpro Private Limited Sarwari –III Hydro Electric Project is located in Kullu district while Siunr Hydro Electric Project is located in Chamba district of Himachal Pradesh. Both the projects are run-of-river (RoR) type hydropower projects built on the Sarwari Nallah (a tributary of river Beas) and river Ravi respectively.

The details of the project and the state of installation are mentioned in the table:

Name of the SPVs investing in HEPs	Capacity in MW	Connection with Grid	State	Usage of Electricity	Date of Commissioning
Gaur Hydro Power Pvt. Ltd.	2 MW	Indian Grid	Himachal Pradesh	Sale to grid	23-February-2018
Gopal Powerpro Private Limited	1.5 MW	Indian Grid	Himachal Pradesh	Sale to grid	05-May-2019
Total	3.5 MW				

Both the project components included in this bundled project activity are run-of-river hydroelectric projects. Electricity generated by using kinetic energy of water which is a renewable source of energy. Electricity generated from 2 MW Gaur HEP is fed in to 33kV Switchyard at Suman sarwari HEP and Siunr HEP via newly constructed 2.7 km long 33 kV overhead transmission line between Sarwari-III and Suman Sarwari switchyard and henceforth taken to the sub-station of Himachal Pradesh State Electricity Board (HPSEB) at Kullu and In case of 1.5 MW Gopal HEP, the electricity generated is sold to HPSEB through connection with 33 /11 kV Grid sub-station at Garola, Himachal Pradesh. The project activity is a renewable energy power project which uses potential energy for power Generation. The energy flow is as follows: potential energy at the project location is converted into mechanical energy using the turbines and subsequently into electrical energy by the generator. The project activity is running very smoothly with scheduled maintenance activity since commissioning.

Hence, it results in reduction of GHG emissions. Estimated GHG emission reductions from the project activity is 14,462 tCO_{2e} and total GHG emission reductions for the chosen 10 year crediting period is 144,622 tonnes of CO_{2e}. During the Current Monitoring Period from 01-September-2021 to 31-July-2022 (First and last date included) the project activity has contributed 8,652 tCO_{2e} GHG reductions.

1.2 Sectoral Scope and Project Type

The project activity falls under the following Sectoral scope and Project Type:

Sectoral Scope : 01 - Energy industries (renewable / non-renewable sources)

Project Type : I - Renewable Energy Projects

Methodology :AMS-I.D. -Grid Connected renewable electricity generation –

Version 18.0.¹

The project is not a grouped project activity

1.3 Project Proponent

Organization name	Gaur Hydro Power Pvt. Ltd
Contact person	Mr. Yugal Kishore Garg
Title	VP Finance
Address	339, Functional Industrial Estate Patparganj Delhi DL 110092 IN
Telephone	09818055221
Email	yugalkishore.garg@gopalcop.com

Organization name	Gopal Power Pro Pvt. Ltd
Contact person	Mr. Yugal Kishore Garg
Title	VP Finance
Address	339, Functional Industrial Estate Patparganj Delhi DL 110092 IN
Telephone	09818055221
Email	yugalkishore.garg@gopalcop.com

1.4 Other Entities Involved in the Project

Organization name	EKI Energy Services Limited
Role in the Project	Project Consultancy

¹ <https://cdm.unfccc.int/UserManagement/FileStorage/2P7FS6ZQAR84LG3NMKYUH50WI9ODBC>

Contact person	Manish Dabkara
Title	CEO
Address	Office No 201, Plot No 48, Scheme 78, Part 2, Vijay Nagar, Indore-452010, Madhya Pradesh
Telephone	+91 9907534900
Email	regsitry@enkingint.org

1.5 Project Start Date

23-February-2018² which is the date of commissioning of first phase of the Project.

1.6 Project Crediting Period

Crediting Period Start date: 23-February-2018

Crediting Period End date: 22-February-2028

The project activity adopts renewable crediting period of 10 years period which can be renewed for maximum 2 times.

1.7 Project Location

The bundled hydro electric project is located in the state of Himachal Pradesh in districts of Kullu and Chamba.

S. No.	Name of the Project Proponent	Village	Tehsil	District	State	Latitude	Longitude
1.	Gaur Hydro Power Private Limited	Dadka, Sarwari nallah	Kullu	Kullu	Himachal Pradesh	31°57'34.9" N	77°03'55.2" E
2.	Gopal Powerpro Private Limited	Garola	Bharmour	Chamba	Himachal Pradesh	32°26'17.8"N	76°28'03.9"E

² As per the commissioning certificate.

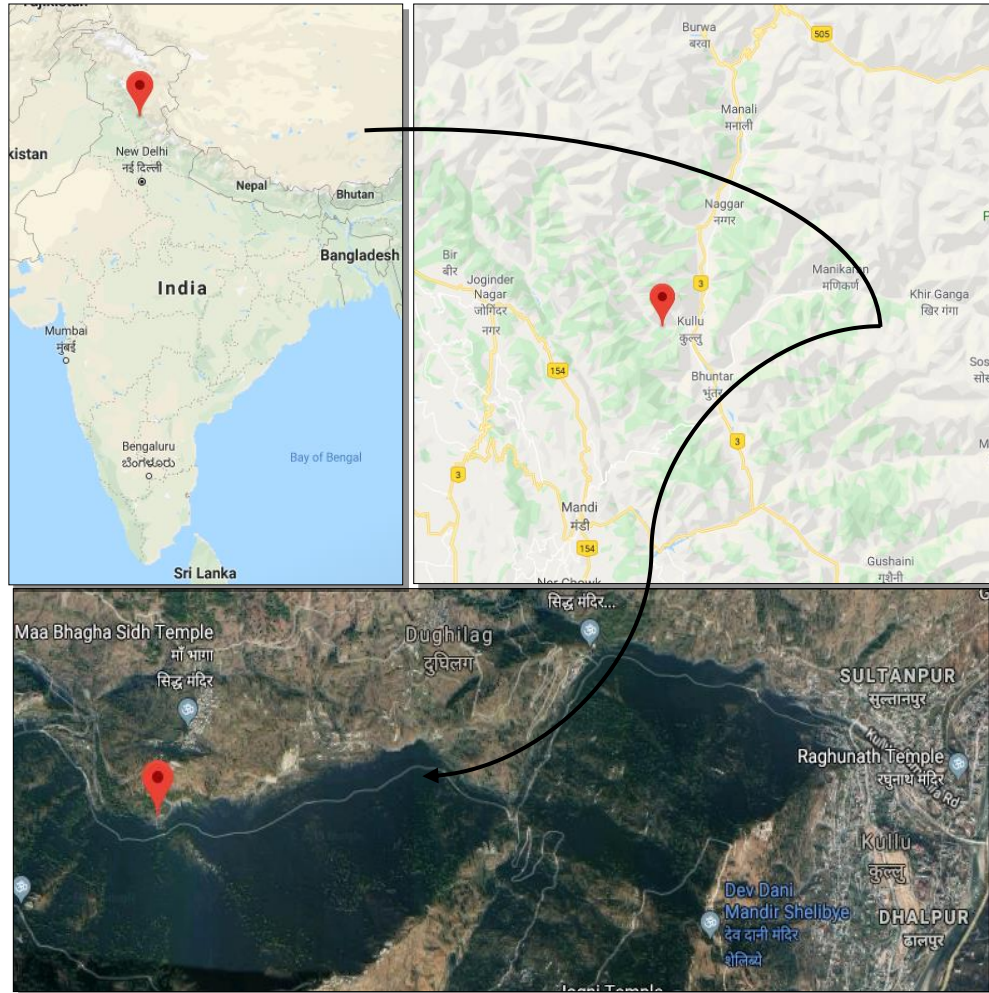

1.8 Title and Reference of Methodology

Title : Grid connected renewable electricity generation

Reference : The project activity meets the eligibility criteria of small scale projects as it is less than 15MW

Methodology : AMS I.D: Grid connected renewable electricity generation (Version 18, EB 81, Annex 24)³

Type I : Energy industries (renewable / non-renewable sources)

Category : Approved Consolidated Methodology (AMS I.D)

Tools referred with above methodology and applicable for project activity are:

- Tool to calculate the emission factor for an electricity system - Version 07.0 (EB 100, Annex 04)⁴

³<https://cdm.unfccc.int/UserManagement/FileStorage/2P7FS6ZQAR84LG3NMKYUH50WI9ODBC>

⁴<https://cdm.unfccc.int/methodologies/PAMethodologies/tools/am-tool-07-v7.0.pdf>

- Methodological Tool- Tool for the demonstration and assessment of additionality- Version 07.0.0 (EB 70, Annex 08)⁵

1.9 Participation under other GHG Programs

The proposed project activity has not been registered and is not seeking registration under any other GHG programs.

This project activity is not participating in any other GHG program.

1.10 Other Forms of Credit

The proposed project activity neither has nor intends to generate any other form of GHG related environmental credit for GHG emission reductions or removals claimed under the VCS Program. The project activity is neither has nor intends to generate any other form of GHG related environmental credit for GHG emission reductions or removals claimed under the VCS Program. As such, the project is registered under VCS program only.

However, it can be crosschecked that PP is not claiming REC benefits, the same can be verified with the REC accreditation body of India.⁶

1.11 Sustainable Development Contributions

Contribution to sustainable development:

The project activity has beneficial effect on the local environment and employment in the nearby region. Clean Electricity generation through hydro project result in avoidance of consumption of fossil fuels which results in contribution to SDG 7. The emission avoidance through these activities results in contribution to SDG 13. All the workers at site are trained which results in increase of skills, which contributes to SDG 4. The project activity generates permanent and temporary employment opportunity within the vicinity of the project. Detailed indicators are mentioned in table 1. This is a voluntary project activity doesn't contribute to achieving any nationally stated sustainable development.

⁵<https://cdm.unfccc.int/methodologies/PAMethodologies/tools/am-tool-01-v7.0.0.pdf>

⁶ https://www.recregistryindia.nic.in/index.php/publics/registered_regens

Table 1: Sustainable Development Contributions

Row number	SDG Target	SDG Indicator	Net Impact on SDG Indicator	Current Project Contributions	Contributions Over Project Lifetime
1)	7.2	7.2.1: Renewable energy share in the total final energy consumption	Implemented activities to increase	About 9,539.71 MWh renewable electricity has supplied to Indian grid during the reported period that helps to increase the renewable energy share in the energy mix.	About 28,033.83 (18,494.12+9,539.71) MWh renewable electricity has supplied to Indian grid that helps to increase the renewable energy share in the energy mix.
2)	13.0	Tonnes of greenhouse gas emissions avoided or removed	Implemented activities to increase	By supplying 9,539.71 MWh clean electricity to Indian grid, the project avoided release of 8,652 tCO ₂ in to the atmosphere during the reporting period.	Prevented the release of 25,528 (16,876+8,652) tCO ₂ e into the atmosphere.
3)	4.4	4.4.1 Proportion of youth and adults with information and communications technology (ICT) skills, by type of skill	Implemented activities to increase	Together with the technology supplier, the Project organize 11 training during current monitoring period. Training related to soft and technical skills.	Overall, 11 trainings are provided during over project lifetime. Current project contribution and lifetime contributions are same as SDG 4 is being reported from this monitoring period only.

2 SAFEGUARDS

2.1 No Net Harm

The facility does not produce any pollution in process of power generation as it utilizes renewable energy source that is hydro energy to generate electricity for captive consumption. Hence there is positive impact on the environment due to this small-scale project activity of reducing the pollution caused by fossil fuels would have been used in baseline scenario. Further this project have no air pollution, no water pollution and no noise pollution. The project activity has obtained the No Objection Certificate for Consent to Establish from the concern agencies.

The project activity does not cause any harm to the local ecology. It primarily requires the installation of the Hydropower project, interfacing the generators with the State Electricity Board by setting up HT transmission lines and installation of other accessories.

Also, as per the Central Pollution Control Board of India notification small hydro project of less than 25 MW falls under White Category and are practically non-polluting⁷.

2.2 Local Stakeholder Consultation

As a part of continual improvement process, feedback from the associated stakeholders is vital, therefore a dedicated Visitor register cum grievance register has been placed at the project site which is accessible to stakeholders to provide their feedback on the project. It is appropriate publicly accessible location at which local stakeholders can provide their feedback on the project. This location is also conducive to continuous and regular checks for stakeholder comments. For the global stakeholders, the suggestion and the grievance can be submitted to yugalkishore.garg@gopalcop.com.

Stakeholder meetings were organized at the time of registration of project activity in order to identify the major challenges around the area, stakeholders were invited well in advance through printed invitation, calls, meeting and a notice is placed around the local common areas. Various CSR activities around site are carried out. The stakeholder is also request to share their experiences and grievances on continuous basis. Registers is used to records the grievances and feedback.

During the current monitoring period, positive feedback is received regarding site operation. No any grievances received during the current monitoring period, therefore, no any mitigation measures are required. In case of grievances, the nature of probable resolution is discussed with

⁷ https://cpcb.nic.in/uploads/Latest_Final_Directions.pdf pg8

the plant head office and implemented by the site in charge. The grievance copies have been submitted to DOE.

2.3 AFOLU-Specific Safeguards

Not applicable to this as this is not an AFOLU project activity.

3 IMPLEMENTATION STATUS

3.1 Implementation Status of the Project Activity

The project activity involves Hydro Electric Projects. The total capacity of the project is 3.5MW. The bundled hydroelectric project is promoted by Gaur Hydro Power Pvt. Ltd. and Gopal Power Pro Pvt. Ltd. The project activity uses hydro energy to generate direct current from turbine that is converted into alternating current by inverters. The project activity has installed a new power plant (i.e. Hydro Electric) at a site where no renewable power plant was operating prior to the implementation of the project activity (green-field plant). The generated electricity is supplied to the INDIAN grid. The project activity follows AMS-I.D. Version 18.0 methodology.

Baseline Scenario:

As per the applicable methodology, a Greenfield power plant is defined as “a new renewable energy power plant that is constructed and operated at a site where no renewable energy power plant was operated prior to the implementation of the project activity”.

As the project activity falls under the definition of a Greenfield power plant, the baseline scenario as per applied methodology is the following:

The baseline scenario is that the electricity delivered to the grid by the project activity would have otherwise been generated by the operation of grid-connected power plants and by the addition of new generation sources into the grid. Hence, pre-project scenario and baseline scenario are the same. The estimated lifetime of the project activity is considered as 40 years for hydro technology. This may increase depending on the operation & maintenance of the plant. The bundled project activity is a new facility (Greenfield) and the electricity generated by the Project is exported to the Indian Grid. The Project therefore displaces an equivalent amount of electricity which would have otherwise been generated by fossil fuel dominant electricity grid. The Project Proponent plans to avail the carbon credits from VCS i.e. VCU benefits for the project.

Emission Reductions from anthropogenic sources:

The solar power generated from the Project is displacing the electricity generated from thermal power stations feeding into Indian grid and is replacing the usage of diesel generators for meeting

the power demand during shortage periods. Since, the hydroelectric electricity is Green House Gas (GHG) emissions free, the power generated is preventing the anthropogenic GHG emissions generated by the fossil fuel based thermal power stations comprising coal, diesel, furnace oil and gas. The estimation of GHG reductions by this project is limited to carbon dioxide (CO₂) only.

The commissioning details of the project are as follows:

Sl.No.	Name of the Project Owner	Capacity (MW)	Commissioning Dates
1.	Gaur Hydro Power Pvt. Ltd	2.0	23-February-2018
2.	Gopal Powerpro Private Limited	1.5	05-May-2019
Total		3.5	

The technical specifications of the plants are described below⁸:

M/S Gaur Hydro Power Pvt Ltd. (2 MW)

Hydrology & Water Area	
Catchment area	138 Sq. Km.
Annual Rainfall	2653 mm
Atmospheric temperature in °C	Min -2°C, Max+ 35°C
Humidity (%)	98%
Head Works	
Diversion Weir	Trench type weir
Weir level	EL 1421 m
Design Discharge	6 cumecs
Flood Discharge	460 cumecs
Bottom level of trench	Carries from EL 1420 to EL 1419
Power Duct	
Shape of Power Duct	Rectangular
Size of Power Duct	1.8 m x 2.6 m
Length of Power duct	130 m
Water Conductor System	
Shape of water conductor	Circular
Size of water conductor	950 m
Desilting tank cum forebay	
Size of Setting Basin	8.5 m wide x 68 m long
Transition (Expansion) from 2.6 m to 8.5 m	18 m
Maximum Flow	8.97 Cumecs
Design discharge	6 Cumecs
Inlet Bottom elevation	EL 1418.94 m
Center elevation of water conductor	EL 1416.88 m

⁸It is to be noted that in future there is possibility of slight change in configuration of projects implemented; however total project capacity of each project will remain same as above.

Penstock	
Diameter of Bifurcation	1.28 m
Length of Bifurcated Penstock	25 m
Turbine / Generator	
Design Flow	3 Cumecs
Gross head	48 m
Design net head	41 m
Design discharge of Machine	6 Cumecs (For two units)
Output at "Design Net Head" & "Design Discharge"	100 kW at Generator Terminals + 20% continuous overload capacity
Type of turbine	Horizontal Francis Machine
Type of Speed Regulation	Multi regulation using Digital Electro Hydraulic Type turbine governor.
Type of Generator	Horizontal, synchronous, Brushless excited, Air cooled open ventilated, 3 phase, having sufficient shaft extension to mount turbine runner.
Rated Speed	750 rpm
Generation voltage	3.3 kV Ph-Ph
Generator Rating	1000 kW, 3.3KV, 0.9 pf, +20% cont. overload capacity.
Power Evacuation	
Voltage rating of setup (Generation) transformer	3.3 kV/ 33kV, ONAN, OLTC
Power rating of generating transformer	2800KVA
Type of tap changer	On Load Tap Changer
Transmission Line Voltage	33 kV
Substation	33KV Grid Substation at Suman Sarwari PH
Length of 33KV single transmission line from PH to substation	2.7 Km long, DOF conductor & XLPE cable if necessary

Gopal Power Pro Pvt. Ltd.

1. Plant Capacity = 2x 0.750 MW (synchronous Generator),
 Generating Voltage 3.3kV
 Voltage 3.3kV
 Current = 154.4A
 PF = 0.85Lag
 Frequency = 50Hz
2. Turbine = 2nosPelton Horizontal
 Model = CJA237-W-105/1x4.5
 Capacity = 789kW
 Speed 750rpm
 Rated Output= 789kW

Rated Speed= 1000rpm
 Runaway Speed= 1732rpm for 10 min.
 Maximum Head =675mtr.
 Rated discharge= 0.163m³/Sec
 Net Head = 675 Mtr

3. Transformer = 2500 kVA
 3.3KV/33KV ONAN OLTC
 Rating = 2500kVA
 IS :2026
 HV voltage 33kV
 LV Voltage 3.3 kV
 HV Current 43.74A
 LV Current 437.40A

4. DG = 25 kVA

There is no technology transfer from Annex-I countries for this project activity.

3.2 Deviations

3.1.1 Methodology Deviations

Not Applicable

3.1.2 Project Description Deviations

There has not been any project description deviation applied during the current monitoring period (01-September-2021 to 31-July-2022).

3.3 Grouped Projects

The project activity is not a grouped project activity.

4 DATA AND PARAMETERS

4.1 Data and Parameters Available at Validation

Data / Parameter	EF _{grid,OM,y}
Data unit	tCO ₂ /MWh
Description	Operating Margin CO ₂ emission factor in year y

Source of data	Calculated from CEA database, Version 14, December 2018 ⁹
Value applied	0.9610
Justification of choice of data or description of measurement methods and procedures applied	Calculated as per “Tool to calculate the emission factor for an electricity system, version 07” as 3-year generation weighted average using data for the years 2015-2016, 2016-2017& 2017-2018. The data are obtained from “CO ₂ Baseline Database for Indian Power Sector” version 14, published by the Central Electricity Authority, Ministry of Power, Government of India.
Purpose of Data	For the calculation of the Baseline Emission
Comments	This parameter is fixed ex-ante for the entire crediting period.

Data / Parameter	$EF_{grid, BM, y}$
Data unit	tCO ₂ /MWh
Description	Build Margin CO ₂ emission factor in year y
Source of data	Calculated from CEA database, Version 14, December 2018
Value applied	0.8644
Justification of choice of data or description of measurement methods and procedures applied	Calculated as per “Tool to calculate the emission factor for an electricity system, version 07” as per the latest data available for the most recent year 2018. The data is obtained from “CO ₂ Baseline Database for Indian Power Sector” version 14, published by the Central Electricity Authority, Ministry of Power, Government of India.
Purpose of Data	For the calculation of the Baseline Emission
Comments	This parameter is fixed ex-ante for the entire crediting period.

Data / Parameter	$EF_{grid, y}$
Data unit	tCO ₂ /MWh
Description	Combined Margin CO ₂ emission factor in year y
Source of data	Calculated from CEA database, Version 14, December 2018
Value applied	0.9127

⁹http://cea.nic.in/reports/others/thermal/tpece/cdm_co2/user_guide_ver14.pdf

Justification of choice of data or description of measurement methods and procedures applied	<p>The combined margin emissions factor is calculated as follows:</p> $EF_{grid,CM,y} = EF_{grid,OM,y} * W_{OM} + EF_{grid, BM,y} * W_{BM}$ <p>Where:</p> <p>$EF_{grid,BM,y}$ = Build margin CO₂ emission factor in year y (tCO₂/MWh) $EF_{grid,OM,y}$ = Operating margin CO₂ emission factor in year y (tCO₂/MWh) W_{OM} = Weighting of operating margin emissions factor (%) = 50% W_{BM} = Weighting of build margin emissions factor (%) = 50%</p> <p>Calculated as per “Tool to calculate the emission factor for an electricity system, version 07.0.0”. The data is obtained from “CO₂ Baseline Database for Indian Power Sector” Version 14, December 2018, published by the Central Electricity Authority, Ministry of Power, Government of India.</p>
Purpose of Data	For the calculation of the Baseline Emission
Comments	This parameter is fixed ex-ante for the entire crediting period.

Data / Parameter	NCV _{Diesel,y}
Data unit	GJ per mass or volume unit (e.g. GJ/m ³ , GJ/ton)
Description	net calorific value of Diesel
Source of data	IPCC default values at the upper limit of the uncertainty at a 95% confidence interval as provided in table 1.2 of Chapter1 of Vol. 2 (Energy) of the 2006 IPCC Guidelines on National GHG Inventories
Value applied	43.3 GJ/Ton
Justification of choice of data or description of measurement methods and procedures applied	<p>Fuel supplier does not provide emission factor in their invoices and also this parameter value is not available top through measurement. Also Regional or national default values are not available.</p> <p>Hence IPCC default values at the upper limit of the uncertainty at a 95% confidence interval as provided in table 1.4 of Chapter1 of Vol. 2 (Energy) of the 2006 IPCC Guidelines on National GHG Inventories.</p> <p>This is in line with Methodological tool “Tool to calculate project or leakage CO₂ emissions from fossil fuel combustion” (Version 3.0). In case of density is required, the same is considered as 0.83 Kg/Lit as per CEA database version 12</p>

Purpose of Data	For the calculation of the Project Emission
Comments	This parameter is fixed ex-ante for the entire crediting period.

Data / Parameter	EF _{CO₂,Diesel,y}
Data unit	tCO ₂ /TJ
Description	CO ₂ Emission Factor of Diesel
Source of data	IPCC default values at the upper limit of the uncertainty at a 95% confidence interval as provided in table 1.4 of Chapter1 of Vol. 2 (Energy) of the 2006 IPCC Guidelines on National GHG Inventories
Value applied	74.8
Justification of choice of data or description of measurement methods and procedures applied	<p>Fuel supplier does not provide emission factor in their invoices and also this parameter value is not available top through measurement. Also Regional or national default values are not available.</p> <p>Hence IPCC default values at the upper limit of the uncertainty at a 95% confidence interval as provided in table 1.4 of Chapter1 of Vol. 2 (Energy) of the 2006 IPCC Guidelines on National GHG Inventories.</p> <p>This is in line with Methodological tool “Tool to calculate project or leakage CO₂ emissions from fossil fuel combustion” (Version 3.0).</p>
Purpose of Data	For the calculation of the Project Emission
Comments	This parameter is fixed ex-ante for the entire crediting period.

4.2 Data and Parameters Monitored

Data / Parameter	EG _{Export,y}
Data unit	MWh
Description	Quantity of electricity exported to the grid in year y
Source of data	Joint Meter Reading issued by HPSEB

Description of measurement methods and procedures to be applied	For measuring the energy delivered by the project activity at the interconnection point, one set of Main meter (part of interconnection facility) and check meter is provided by the company and the HPSEB at the interconnection point. Monthly joint meter readings of the main meter and check meter at the interconnection point has been taken by the designated officials of the company and HPSEB. The joint meter readings has been recorded and signed by the authorized representative of both the parties on each of the above instances.																								
Frequency of monitoring/recording	Continuous Metering, and monthly recording has been done.																								
Value monitored	9,546.25																								
Monitoring equipment	<p>For the uninterrupted metering system the PP has kept 2 identical meters which are used as the two sets of Main and Check Meter as mentioned below:</p> <table border="1" data-bbox="634 821 1300 1066"> <tr> <td data-bbox="634 821 857 951">Gaur Hydro Power Private Limited</td> <td data-bbox="857 821 1078 877">HPU 06256</td> <td data-bbox="1078 821 1300 877">Meter 1</td> </tr> <tr> <td data-bbox="634 877 857 951"></td> <td data-bbox="857 877 1078 951">HPU 06255</td> <td data-bbox="1078 877 1300 951">Meter 2</td> </tr> <tr> <td data-bbox="634 951 857 1066">Gopal Powerpro Private Limited</td> <td data-bbox="857 951 1078 1008">13193404</td> <td data-bbox="1078 951 1300 1008">Meter 1</td> </tr> <tr> <td data-bbox="634 1008 857 1066"></td> <td data-bbox="857 1008 1078 1066">13193345</td> <td data-bbox="1078 1008 1300 1066">Meter 2</td> </tr> </table> <p>These 2 sets of meters are used alternatively after 6 months. While the one set of meters are in function the other set of meters are kept idle after laboratory tests in ready to use condition. The detail of each meter have been provided below:</p> <table border="1" data-bbox="634 1234 1414 1472"> <thead> <tr> <th data-bbox="634 1234 889 1291"></th> <th data-bbox="889 1234 1154 1291">Gaur HEP</th> <th data-bbox="1154 1234 1414 1291">Gopal HEP</th> </tr> </thead> <tbody> <tr> <td data-bbox="634 1291 889 1348">Meter Type</td> <td data-bbox="889 1291 1154 1348">ABT Meter</td> <td data-bbox="1154 1291 1414 1348">ABT Meter</td> </tr> <tr> <td data-bbox="634 1348 889 1404">Manufacturer</td> <td data-bbox="889 1348 1154 1404">Secure Make</td> <td data-bbox="1154 1348 1414 1404">L & T Make</td> </tr> <tr> <td data-bbox="634 1404 889 1461">Accuracy Class</td> <td data-bbox="889 1404 1154 1461">0.2s</td> <td data-bbox="1154 1404 1414 1461">0.2s</td> </tr> </tbody> </table> <p>The main and check meters in each sets are also exchanged on the rotational basis. The summary of Meters used as the main and check meter has been provided in Appendix 2.</p>	Gaur Hydro Power Private Limited	HPU 06256	Meter 1		HPU 06255	Meter 2	Gopal Powerpro Private Limited	13193404	Meter 1		13193345	Meter 2		Gaur HEP	Gopal HEP	Meter Type	ABT Meter	ABT Meter	Manufacturer	Secure Make	L & T Make	Accuracy Class	0.2s	0.2s
Gaur Hydro Power Private Limited	HPU 06256	Meter 1																							
	HPU 06255	Meter 2																							
Gopal Powerpro Private Limited	13193404	Meter 1																							
	13193345	Meter 2																							
	Gaur HEP	Gopal HEP																							
Meter Type	ABT Meter	ABT Meter																							
Manufacturer	Secure Make	L & T Make																							
Accuracy Class	0.2s	0.2s																							
QA/QC procedures to be applied	<p>The meters have been tested by the Power Grid Corporation of India Ltd, (An external entity and a Government owned enterprises), in the Regional Test Laboratory i.e. Northern Region II (Jalandhar). The meter test records have been maintained in the plant.</p> <p>The meters is approved, tested & sealed by the State Utility. The meters are in the custody of State Utility. The frequency of</p>																								

	calibration is once in 5 years. ¹⁰ The monthly electricity supplied/exported by the project activity in the form of JMR report is cross checked with the monthly invoices of sale to the State SEB. In the absence or delay in the meter calibration appropriate Guidelines would be applied appropriately to confirm the conservativeness of metering
Purpose of the data	Calculation of baseline emissions
Calculation method	Electricity exported to grid by the project activity has been directly monitored by the main meter. Thus, calculation is not necessary for this parameter.
Comments	The data is being archived electronically and kept for 2 years beyond the Crediting Period or last issuance whichever is later

Data / Parameter	EG _{Import, y}										
Data unit	MWh										
Description	Quantity of electricity imported from the grid in year y										
Source of data	Joint Meter Reading issued by HPSEB										
Description of measurement methods and procedures to be applied	<p>For measuring the energy imported by the project activity at the interconnection point, one set of Main meter (part of interconnection facility) and check meter is provided by the company and the HPSEB at the interconnection point.</p> <p>Monthly joint meter readings of the main meter and check meter at the interconnection point has been taken by the designated officials of the company and HPSEB. The joint meter readings has been recorded and signed by the authorized representative of both the parties on each of the above instances.</p>										
Frequency of monitoring/recording	Continuous Metering, and monthly recording has been done										
Value monitored	6.54										
Monitoring equipment	<p>For the uninterrupted metering system the PP has kept 4 identical meters which are used as the two sets of Main and Check Meter as mentioned below:</p> <table border="1"> <tr> <td rowspan="2">Gaur Hydro Power Private Limited</td> <td>HPU 06256</td> <td>Meter 1</td> </tr> <tr> <td>HPU 06255</td> <td>Meter 2</td> </tr> <tr> <td rowspan="2">Gopal Powerpro Private Limited</td> <td>13193404</td> <td>Meter 1</td> </tr> <tr> <td>13193345</td> <td>Meter 2</td> </tr> </table>	Gaur Hydro Power Private Limited	HPU 06256	Meter 1	HPU 06255	Meter 2	Gopal Powerpro Private Limited	13193404	Meter 1	13193345	Meter 2
Gaur Hydro Power Private Limited	HPU 06256		Meter 1								
	HPU 06255	Meter 2									
Gopal Powerpro Private Limited	13193404	Meter 1									
	13193345	Meter 2									

¹⁰http://www.aegcl.co.in/Metering_Regulations_Of_CEA_17_03_2006.pdf

	<p>These 2 sets of meters are used alternatively after 6 months. While the one set of meters are in function the other set of meters are kept idle after laboratory tests in ready to use condition. The detail of each meter have been provided below:</p> <table border="1"> <thead> <tr> <th></th> <th>Gaur HEP</th> <th>Gopal HEP</th> </tr> </thead> <tbody> <tr> <td>Meter Type</td> <td>ABT Meter</td> <td>ABT Meter</td> </tr> <tr> <td>Manufacturer</td> <td>Secure Make</td> <td>L & T Make</td> </tr> <tr> <td>Accuracy Class</td> <td>0.2s</td> <td>0.2s</td> </tr> </tbody> </table> <p>The main and check meters in each sets are also exchanged on the rotational basis. The summary of Meters used as the main and check meter has been provided in Appendix 1.</p>		Gaur HEP	Gopal HEP	Meter Type	ABT Meter	ABT Meter	Manufacturer	Secure Make	L & T Make	Accuracy Class	0.2s	0.2s
	Gaur HEP	Gopal HEP											
Meter Type	ABT Meter	ABT Meter											
Manufacturer	Secure Make	L & T Make											
Accuracy Class	0.2s	0.2s											
QA/QC procedures to be applied	<p>The meters have been tested by the Power Grid Corporation of India Ltd, (An external entity and a Government owned enterprises), in the Regional Test Laboratory i.e. Northern Region II (Jalandhar). The meter test records have been maintained in the plant.</p> <p>The meters are approved, tested & sealed by the State Utility. The meters are in the custody of State Utility. The frequency of calibration is once in 5 years.¹¹ The monthly electricity supplied/exported by the project activity in the form of JMR report is cross checked with the monthly invoices of sale to the State SEB. In the absence or delay in the meter calibration appropriate Guidelines is applied appropriately to confirm the conservativeness of metering.</p>												
Purpose of the data	Calculation of baseline emissions												
Calculation method	Electricity imported from the grid by the project activity has been directly monitored by the main meter. Thus, calculation is not necessary for this parameter.												
Comments	The data is being archived electronically and kept for 2 years beyond the Crediting Period or last issuance whichever is later												
Data / Parameter	EG _{PJ,y}												
Data unit	MWh												
Description	Quantity of net electricity exported to the grid in year y												
Source of data	Calculated												

¹¹http://www.aegcl.co.in/Metering_Regulations_Of_CEA_17_03_2006.pdf

Description of measurement methods and procedures to be applied	<p>For measuring the net energy export by the project activity at the interconnection point,</p> <p>Following Formula is being used:</p> $EG_{PJ,y} = EG_{Export,y} - EG_{Export,y}$ <p>This net export reading is calculated in through the Monthly joint meter readings of the main meter and check meter at the interconnection point, taken by the designated officials of the company and HPSEB. The joint meter readings have been recorded and signed by the authorized representative of both the parties on each of the above instances.</p>																						
Frequency of monitoring/recording	Continuous Metering, and monthly recording has been done																						
Value monitored	9,539.71																						
Monitoring equipment	<p>For the uninterrupted metering system the PP has kept 4 identical meters which are used as the two sets of Main and Check Meter as mentioned below:</p> <table border="1" data-bbox="634 919 1308 1167"> <tr> <td rowspan="2">Gaur Hydro Power Private Limited</td> <td>HPU 06256</td> <td>Meter 1</td> </tr> <tr> <td>HPU 06255</td> <td>Meter 2</td> </tr> <tr> <td rowspan="2">Gopal Powerpro Private Limited</td> <td>13193404</td> <td>Meter 1</td> </tr> <tr> <td>13193345</td> <td>Meter 2</td> </tr> </table> <p>These 2 sets of meters are used alternatively after 6 months. While the one set of meters are in function the other set of meters are kept idle after laboratory tests in ready to use condition. The detail of each meter have been provided below:</p> <table border="1" data-bbox="634 1335 1414 1535"> <tr> <td></td> <td>Gaur HEP</td> <td>Gopal HEP</td> </tr> <tr> <td>Meter Type</td> <td>ABT Meter</td> <td>ABT Meter</td> </tr> <tr> <td>Manufacturer</td> <td>Secure Make</td> <td>L & T Make</td> </tr> <tr> <td>Accuracy Class</td> <td>0.2s</td> <td>0.2s</td> </tr> </table> <p>The main and check meters in each sets are also exchanged on the rotational basis. The summary of Meters used as the main and check meter has been provided in Appendix 1.</p>	Gaur Hydro Power Private Limited	HPU 06256	Meter 1	HPU 06255	Meter 2	Gopal Powerpro Private Limited	13193404	Meter 1	13193345	Meter 2		Gaur HEP	Gopal HEP	Meter Type	ABT Meter	ABT Meter	Manufacturer	Secure Make	L & T Make	Accuracy Class	0.2s	0.2s
Gaur Hydro Power Private Limited	HPU 06256		Meter 1																				
	HPU 06255	Meter 2																					
Gopal Powerpro Private Limited	13193404	Meter 1																					
	13193345	Meter 2																					
	Gaur HEP	Gopal HEP																					
Meter Type	ABT Meter	ABT Meter																					
Manufacturer	Secure Make	L & T Make																					
Accuracy Class	0.2s	0.2s																					
QA/QC procedures to be applied	<p>The meters have been tested by the Power Grid Corporation of India Ltd, (An external entity and a Government owned enterprises), in the Regional Test Laboratory i.e. Northern Region II (Jalandhar). The meter test records have been maintained in the plant.</p>																						

	The meters is approved, tested & sealed by the State Utility. The meters are in the custody of State Utility. The frequency of calibration is once in 5 years. ¹² The monthly electricity supplied/exported by the project activity in the form of JMR report is cross checked with the monthly invoices of sale to the State SEB. In the absence or delay in the meter calibration appropriate Guidelines are applied appropriately to confirm the conservativeness of metering.
Purpose of the data	Calculation of baseline emissions
Calculation method	Electricity imported from the grid by the project activity has been directly monitored by the main meter. Thus, calculation is not necessary for this parameter
Comments	The data is archived electronically and it is kept for 2 years beyond the Crediting Period or last issuance whichever is later

Data / Parameter	FC _{diesel, y}
Data unit	Tons
Description	Quantity of Diesel consumed by the standby DG set in year y
Source of data	Records of levels in the diesel storage tanks as per the plant log book.
Description of measurement methods and procedures to be applied	Measurement Procedure: The diesel quantity available in the diesel storage tanks is recorded daily by PP in the plant log book. The diesel consumption has been recorded in the logbook in litres. However, based on the density of diesel of about 0.88 ¹³ kg/litre, the diesel consumption in tons has been calculated for use in the equation to compute project emissions (PE) as mentioned in above section. Accuracy of the Measurement Method: To confirm the accuracy on measurement of quantity of diesel consumed in the project activity can be cross checked against the fuel purchase receipts. Responsibility: Log book has been maintained by the shift in charge and same has been cross checked by the General Manager of the project activity.
Frequency of monitoring/recording	Frequency: Continuously monitored.

¹²http://www.aegcl.co.in/Metering_Regulations_Of_CEA_17_03_2006.pdf

¹³Reference: Requirement of High Speed Diesel (HSD) fuel as per IS 1460: 1995 as specified under Motor spirit and High Speed Diesel Control Orders by the Ministry and Petroleum and Natural Gas (MoPNG) dated 28 December 1998 available at <http://petroleum.nic.in/newgazette/GN%20No.511%20dtd%2029-12-98.p>

	Recording frequency: monthly and aggregated annually Archiving Policy: Paper & Electronic
Value monitored	0.01629 kt (18,514 litres)
Monitoring equipment	Manually Monitoring
QA/QC procedures to be applied	The data recorded can be cross checked against the fuel purchase receipts
Purpose of the data	Calculation of project emissions
Calculation method	It has been directly monitored. Thus, calculation is not necessary for this project.
Comments	The above parameter is being monitored ex-post and the values will be updated accordingly. The data will be archived electronically and will be kept for 2 years beyond the Crediting Period or last issuance whichever is later

4.3 Monitoring Plan

The data monitoring involves the parameters mentioned in the section 3.2. Due care has been taken for the measurement of all these parameters and maintenance of records. Proper training has been imparted to concerned personnel for accurate measurement:

Metering:

Electricity export and import are metered by main and check tri-vector energy meters with an accuracy class of 0.2s installed at the grid interconnection point. The main meter reading is taken jointly on a fixed day of every month for the preceding month and signed by the representatives of state utility and PP. In the event of failure of main meter installed at the substation, the check meter is used in monitoring the electricity data. All the meters are under the custody of HPSEB who is responsible for the calibration of the energy meters as per the industry standards. PP has proposed calibration of meter once in three year. All data is archived electronically and are kept for a minimum of 2 years beyond the crediting period or last issuance whichever is later.

Monitoring Organization:

The Project is being managed by the Managing Director (MD), General Manager, Manager (Operations), Technical in-charge and Manager (finance). The authority and responsibility for registration, monitoring, measurement, reporting and reviewing of the data rests with the MD (through a dedicated identified person) The identified person is in charge of GHG monitoring activities and prepare necessary audit reports for review by the management. The identified person in charge is also assisted by a team of experienced personnel indisciplines such as mechanical and electrical with experience in plant operation, measurements and

management. The primary responsibility of the team is to collect, measure, monitor, record and reports the information on various data items to the person in charge and the General Manager, in accordance with the applicable standards. Periodic calibration of various instruments used in the monitoring of the data and recordkeeping of the same is also the responsibility of this team. The responsibility of storage and archiving of information in good condition also lies with the designated person in charge. The person in-charge also undertake periodic verifications and onsite inspections to ensure the quality of the data collected by the team.

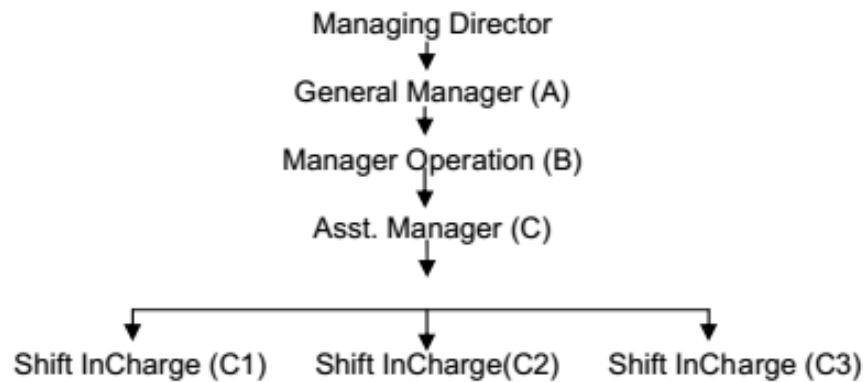

Where,

- A : General Manager is the responsible for the overall project activities
- B : Manger Operation is responsible for the technical aspects of the project including calibration of the energy in due time.
- C : Asst. Manager (C) will assist the Manager Operation and looks after the day-to-day shift activity of the project.
- C1, C2, C3 : 3 Shift In Charge who are placed in 3 shifts and also take care of the technical faults occurring in the plant

Monitoring equipment comprises of energy meters, which monitor the energy fed by the plant to grid system by the proposed project. Project proponents has installed two energy meters. One is main meter and the other is check meter. Both the meters are calibrated at regular intervals. The baseline emission factor is taken from the official data published by the Central Electricity Authority for the Integrated Indian grid. GHG Data Collection System: The data flow of the collected GHG data is mentioned in below line diagram:

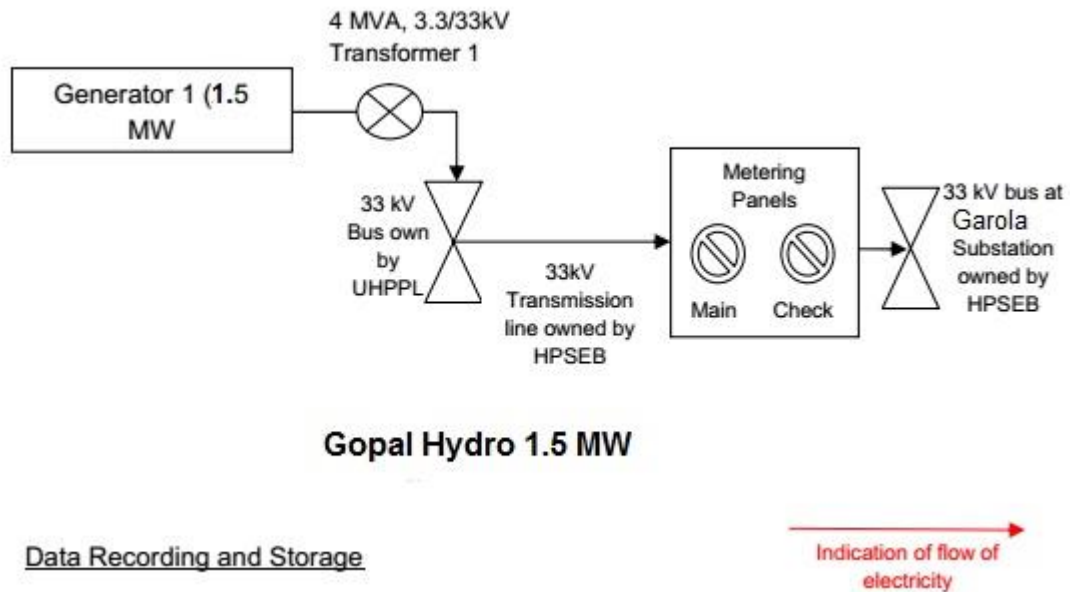
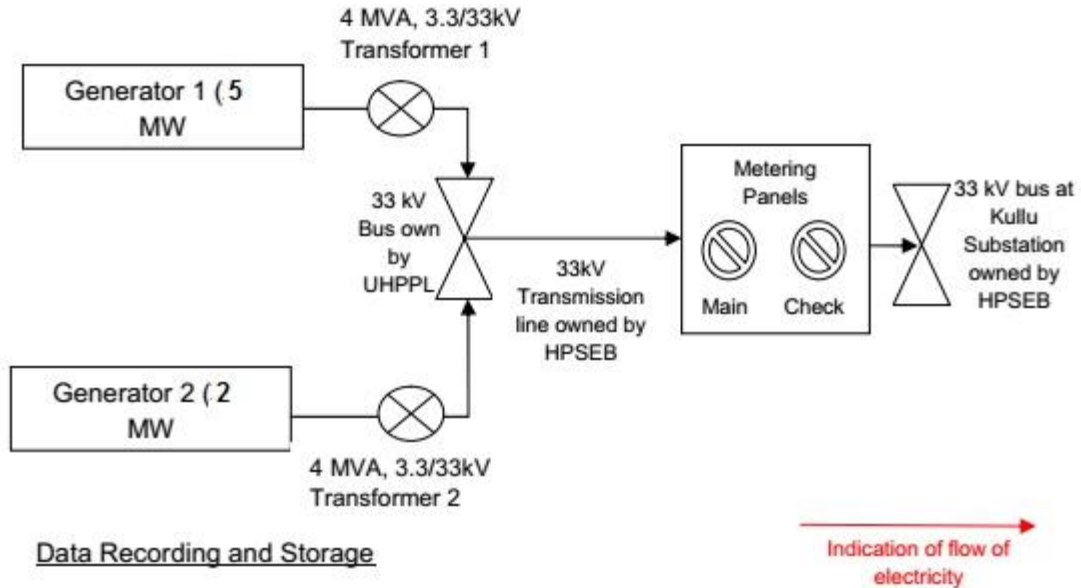

The net energy fed to the grid system by the project activity is recorded by project proponents using Main Meter. However, at the time of non-performance of main meter, the check meter is referred. The document which contains all details such as the equipment data, calibration status, previous readings, current reading, export, net billable units, date and time of recording etc. This document is used as a basic document for monitoring and verification of the net energy exported to the grid. The State Electricity Board pays to the project proponent based on this document.

QA & QC Procedures to be followed:

There has not been a single instance of meter failure during the monitoring period considered, hence no such process was applied. However, the scheduled calibrations were done as per the industry standard.

5 QUANTIFICATION OF GHG EMISSION REDUCTIONS AND REMOVALS

5.1 Baseline Emissions

According to the paragraph 22 of the 18th version of AMS I.D, the baseline emissions are the product of electrical energy baseline $EG_{PJ,y}$ expressed in MWh of electricity produced by the renewable generating unit multiplied by the grid emission factor.

$$BE_y = EG_{PJ,y} \times EF_{grid,y}$$

Where,

BE_y = Baseline Emissions in year y; tCO₂

$EG_{PJ,y}$ = Quantity of net electricity supplied to the grid as a result of the implementation of the CDM project activity in year y (MWh)

$EF_{CO_2,grid,y}$ = CO₂ Emission Factor of the grid in year y; tCO₂/MWh

Thus, baseline emissions can be calculated as

$$\begin{aligned} BE_y &= EG_{PJ,y} \times EF_{grid,y} \\ &= (9,539.71) \times 0.9127 \\ &= 8,706 \text{ tCO}_2\text{e.} \end{aligned}$$

Baseline Emissions from (01-September-2021 to 31-July-2022)

Parameter Period	Quantity of net electricity supplied to the grid as a result of the implementation of the project activity in year y (MWh) ($EG_{BL,y}$)	CO ₂ Emission Factor of the grid in year y (tCO ₂ /MWh) ($EF_{CO_2,grid,y}$)	Baseline Emissions in year y (tCO ₂) (BE_y)
01-September-2021 to 31-December-2021	2,787.48	0.9127	2,544
01-January-2022 to 31-July-2022	6,752.23	0.9127	6,162

5.2 Project Emissions

Since one diesel generator is also being utilized to supply the emergency requirement for the project activity, diesel consumption is monitored in plant log records. Emissions resulting from usage of diesel in the backup diesel generator is accounted as project emissions based on the following equation as provided in the “Tool to calculate project or leakage CO₂ emissions from fossil fuel combustion” version.3¹⁴. CO₂ emissions from fossil fuel combustion in process are calculated based on the quantity of fuels combusted and the CO₂ emission coefficient of those fuels, as follows:

CO₂ emissions from fossil fuel combustion in process j are calculated based on the quantity of fuels combusted and the CO₂ emission coefficient of those fuels, as follows:

$$PE_{FC, j, y} = \sum FC_{i, j, y} \times COEF_{i, y}$$

Where:

$PE_{FC, j, y}$ = Are the CO₂ emissions from diesel combustion in process j during the year y (tCO₂/yr);

$FC_{i, j, y}$ = Is the quantity of diesel combusted in process j during the year y (mass or volume unit/yr);

$COEF_{i, y}$ = Is the CO₂ emission coefficient of diesel in year y (tCO₂/mass or volume unit)

i = Are the fuel types combusted in process j during the year y

The CO₂ emission coefficient $COEF_{i, y}$: PP has selected the option B as COEF (CO₂emission coefficient of fuel) testing facility for “Weighted average mass fraction of carbon in fuel type i in year y” under option A is not available to PP.

Option B: The CO₂ emission coefficient $COEF_{i, y}$ is calculated based on net calorific value and CO₂ emission factor of the diesel, as follows:

$$COEF_{i, y} = NCV_{diesel, y} \times EF_{CO_2, diesel, y}$$

Where:

$COEF_{i, y}$ = CO₂ emission coefficient of diesel in year y (tCO₂/mass or volume unit)

$NCV_{diesel, y}$ = weighted average net calorific value of the diesel in year y (GJ/mass or volume unit)

$EF_{CO_2, diesel, y}$ = weighted average CO₂ emission factor of diesel in year y (tCO₂/GJ)

Hence, the project emissions for the proposed project activity can be calculated as follows:

$$PE_{diesel, j, y} = FC_{diesel, j, y} \times NCV_{diesel, y} \times EF_{CO_2, diesel, y}$$

¹⁴<https://cdm.unfccc.int/methodologies/PAmethodologies/tools/am-tool-03-v3.pdf>

Where,

$FC_{diesel, j, y}$ = quantity of diesel used during the year

$NCV_{diesel, y}$ = weighted average net calorific value of diesel in year y

$EF_{CO_2, diesel, y}$ = weighted average CO₂ emission factor of fuel type diesel in year y

Hence for the Monitoring Period 02-01-September-2021 to 31-July-2022.

Parameter Period	Quantity of Diesel consumed by the standby DG set in year y ($FC_{diesel, y}$) (Lts)	Weighted Average net Calorific Value of Diesel combusted in the project activity during the year, y ($NCV_{Diesel, y}$) (GJ/Ton)	Weighted average CO ₂ emission factor of the diesel consumed in the project activity in year y ($EF_{CO_2, diesel, y}$) (tCO ₂ /TJ)	Project Emission (after rounding up) (tCO ₂)
01-September-2021 to 31-December-2021	2,524	43.3	74.8	8
01-January-2022 to 31-July-2022	15,990	43.3	74.8	46

5.3 Leakage

As per AMS ID version 18 “If the energy generating equipment is transferred from another activity, leakage is to be considered”. It is denoted by LE_y , However there is no equipment transferred from another activity hence, Hence $LE_y=0$

5.4 Net GHG Emission Reductions and Removals

The emission reductions (ER_y) by the Project activity during a given year y is the difference between baseline emissions (BE_y), project activity emissions (PE_y) and leakage (LE_y), as follows:

$$ER_y = BE_y - PE_y - LE_y$$

Therefore emission reductions generated by the Project during this monitoring period (01-September-2021 to 31-July-2022) are calculated as:

Year	Baseline emissions or removals (tCO ₂ e)	Project emissions or removals (tCO ₂ e)	Leakage emissions (tCO ₂ e)	Net GHG emission reductions or removals (tCO ₂ e)
01-September-2021 to 31-December-2021	2,544	8	0	2,536

01-January-2022 to 31-July-2022	6,162	46	0	6,116
Total	8,706	54	0	8,652

$$ER_y = BE_y - PE_y - LE_y$$

$$= 8,706 - 54 - 0$$

$$= 8,652 \text{ tCO}_2\text{e}$$

There was no breakdown of the bundled project activity during the current monitoring period.

Based upon the annual estimated emission reduction from the project activity, the estimated emission reduction for the current monitoring period is 13,234 tCO₂e, whereas actual emission reductions achieved are 8,652 tCO₂e, which is approximately 34.62% lower than the estimated emission reductions. The generation of electricity depends upon many other climatic conditions, which are not within the control of the project participant. The lower generation during the current verification period is low due to certain natural conditions like water flow etc. Hence, it is acceptable.

Apart from above comparison, the estimated emission reduction comparison with actual emission reductions based on operation days of each PP. Based on actual operational days, the estimation for operational days and actual emission reductions are compared and found that for the project activity the power generation was on a lower side and witnessed downfall in PLF.

APPENDIX 1: CALIBRATION AND METER DETAILS

Metering arrangement, monitoring practice, accuracy class, calibration frequency are under control of state electricity board, the PPs do not have any control on monitoring practice and calibration of meters. Being Greenfield project activity and commissioned within 2 years, all meters are used for monitoring purpose are pre calibrated before installation as per state electricity board regulations, thus installed pre calibrated meters have validity of calibration till 5 years of commissioning date.

The Energy Meters details used for the respective project proponents are given below:

Name of the SPVs	Site	Capacity (MW)	Main Meter Details	Check Meter Details	Calibration Date	Due date
Gaur Hydro Power Pvt. Ltd.	Dadka, Kullu	2.0	SL. No. : HPU06256 Make: Secure I Accuracy class: 0.2s	SL. No. : HPU06255 Make: Secure	25-August-2018	06-August-2026
					07-August-2021	
Gopal Power Pro Pvt. Ltd.	Garola, Chamb a	1.5	SL. No. : 13193404 Make: L&T Accuracy class: 0.2s	SL. No. : 13193345 Make: L & T	23-January-2020	06-September-2026
					06-September-2021	

APPENDIX 2: BREAKDOWN DETAILS

In Gopal Power Pro Private Limited, plant was shut-down from 14-January 2022 to 09-March-2022 due to water conduct, damaged channel and from 12-March-2022 to 18-March-2022 due to grid failure from Pilli Substation. For rest of the monitoring period plant worked fine.

No major breakdown happened during the current monitoring period in Gaur Hydro Power Private Limited.