



Gold Standard[®]
for the Global Goals

Climate Security & Sustainable Development

TEMPLATE

KEY PROJECT INFORMATION & PROJECT DESIGN DOCUMENT (PDD)

PUBLICATION DATE 14.10.2020

VERSION v. 1.2

RELATED SUPPORT

- **TEMPLATE GUIDE Key Project Information & Project Design Document v.1.2**

This document contains the following Sections

Key Project Information

SECTION A – Description of project

SECTION B - Application of approved Gold Standard Methodology (ies) and/or demonstration of SDG Contributions

SECTION C – Duration and crediting period

SECTION D – Summary of Safeguarding Principles and Gender Sensitive Assessment

SECTION E – Outcome of Stakeholder Consultations

Appendix 1 – Safeguarding Principles Assessment (mandatory)

Appendix 2 - Contact information of Project participants (mandatory)

Appendix 3 - LUF Additional Information (project specific)

Appendix 3 - Summary of Approved Design Changes (project specific)

KEY PROJECT INFORMATION

GS ID of Project	GS5519
Title of Project	70 MW Bhadla Solar power plant by Fortum FinnSurya Energy Pvt Ltd (EKIESL-CDM-APRIL-16-01)
Time of First Submission Date	08/08/2022
Date of Design Certification	03/01/2018
Version number of the PDD	03
Completion date of version	04/01/2023
Project Developer	Fortum FinnSurya Energy Pvt. Ltd.
Project Representative	Infinite Solutions
Project Participants and any communities involved	Fortum FinnSurya Energy Pvt. Ltd.
Host Country (ies)	India
Activity Requirements applied	<input type="checkbox"/> Community Services Activities <input checked="" type="checkbox"/> Renewable Energy Activities <input type="checkbox"/> Land Use and Forestry Activities/Risks & Capacities <input type="checkbox"/> N/A
Scale of the project activity	<input type="checkbox"/> Micro scale <input type="checkbox"/> Small Scale <input checked="" type="checkbox"/> Large Scale
Other Requirements applied	NA
Methodology (ies) applied and version number	ACM0002 Version 20 Grid-connected electricity generation from renewable sources
Product Requirements applied	<input checked="" type="checkbox"/> GHG Emissions Reduction & Sequestration <input type="checkbox"/> Renewable Energy Label <input type="checkbox"/> N/A
Project Cycle:	<input type="checkbox"/> Regular <input checked="" type="checkbox"/> Retroactive

Table 1 – Estimated Sustainable Development Contributions

Sustainable Development Goals Targeted	SDG Impact (defined in B.6.)	Estimated Annual Average	Units or Products
7 Affordable and Clean Energy	MWh of renewable energy generated	121,420 MWh/Annum	
8 Decent Work and Economic Growth	Trainings Employees Income Generation	1 No of Training 10 No of Employees The income to all the unskilled workers are made on day-to-day basis better than the minimum wage requirements: 357 INR.	
13 Climate Action (mandatory)	Emission Reduction	112,980 tCO2/Annum	

SECTION A. DESCRIPTION OF PROJECT

A.1 Purpose and general description of project

>>

Start date of project activity 29/07/2016¹

The main purpose of this project activity is to generate clean form of electricity through renewable solar energy source. Fortum FinnSurya Energy Pvt. Ltd. is the promoter of the project activity. The project activity involves installation of 70 MW (AC) (88.2 MWp) solar power project at Bhadla, Jodhpur, Rajasthan. The annual average of estimated electricity generation and estimated emission reduction over 5 years of crediting period is 121,420 MWh/year and 112,980 tCO₂e per year. The project replaces anthropogenic emissions of greenhouse gases (GHG's) by displacing equivalent amount of electricity from the generation-mix of power plants connected to the Indian grid, which is mainly dominated by thermal/fossil fuel based power plant.

The details of the project and the state of installation are mentioned in the table: -

Project Promoters' Name	Capacity in MW (AC)	Connection with Grid	State
Fortum FinnSurya Energy Pvt. Ltd.	70 MW	INDIAN	Rajasthan

Sectoral Scope: 01: "Grid-connected electricity generation from renewable sources", ACM0002- Version 20.0"

Project Type: (i) : Renewable energy projects

Scenario existing prior to the implementation of project activity:

¹ Purchase order provided for documentary evidence of start date.

The scenario existing prior to the implementation of the project activity, is electricity delivered to the grid by the project activity that would have otherwise been generated by the operation of grid- connected power plants and by the addition of new generation sources, as reflected in the combined margin (CM) calculations described in the “Tool to calculate the emission factor for an electricity system”.

Baseline Scenario:

As per the applicable methodology, a Greenfield power plant is defined as “a new renewable energy power plant that is constructed and operated at a site where no renewable energy power plant was operated prior to the implementation of the project activity”.

As the project activity falls under the definition of a Greenfield power plant, the baseline scenario as per applied methodology is the following:

The baseline scenario is that the electricity delivered to the grid by the project activity would have otherwise been generated by the operation of grid-connected power plants and by the addition of new generation sources into the grid.

Hence, pre-project scenario and baseline scenario are the same.

Sustainable development indicators

The National CDM Authority (NCDMA), which is the Designated National Authority (DNA) for the Government of India (GOI) under the Ministry of Environment and Forests (MoEF), has mentioned four indicators for the sustainable development in the interim approval guidelines for Clean Development Mechanism (CDM) projects from India. Thus, the project’s contribution towards sustainable development has been addressed based on the following sustainable development aspects:

Social well-being

The project activity provided / provides job opportunity to local people during erection, commissioning and maintenance of the solar project. Frequency of visiting villages and nearby areas by skilled, technical and industrialist increase due to installation /site visit/operation and maintenance work related to solar plant. This directly and indirectly positively effects the economy of villages and nearby area.

Environmental well-being

Solar power is one of the cleanest renewable energy powers and does not involve any fossil fuel. There are no GHG emissions. The impact on land, water, air and soil is negligible. Thus, the project activity contributes to environmental well-being without causing any negative impact on the surrounding environment.

Economic well-being

The project activity generates permanent and temporary employment opportunity within the vicinity of the project. The electricity supply in the nearby area improves which directly and indirectly improves the economy and lifestyle of the area.

Technological well-being

The project activity is step forward in harnessing the untapped solar potential and further diffusion of the solar technology in the region. The project activity leads to the promotion and demonstrates the success of solar projects in the region which further motivate more investors to invest in solar power projects. Hence, the project activity leads to technological well-being.

As a part of Sustainability Policy, Fortum wants to excel in sustainability and believes that balanced management of economic, environmental and social responsibility brings us a competitive advantage, is beneficial to our stakeholders and is necessary for the development of future societies. We continuously improve our sustainability performance by assessing our impacts and by addressing sustainability throughout the value chain.

Economic responsibility

For Fortum, economic responsibility means competitiveness, performance excellence and market- driven production that creates long-term value and enables sustainable growth. We promote market- based policies and measures that help to solve global sustainability challenges and targets in the most efficient way. We understand that our operations provide both direct and indirect economic benefits to our stakeholders, and we continuously review our impact and the well-being generated.

Environmental responsibility

Fortum’s aim is to provide our customers with environmentally benign energy products and services. We are committed to environmentally sound business practices and to the responsible use of natural resources. We take into account the life-cycle of our energy products and continuously aim to mitigate our environmental impact by utilizing best practices and best available technologies. We want to minimize environmental non-compliances and incidents caused by our operations. Mitigation of climate change and the preservation of natural resources are key priorities in our environmental approach. Our competence in CO₂-free hydro and nuclear power production and in energy-efficient combined heat and power production support the development of low-carbon societies.

Social responsibility

For Fortum, excellence in safety is the foundation of our business and safe performance is a sign of professionalism. We believe that all work-related injuries, illnesses and safety incidents can be prevented. Fortum’s goal is to provide a safe working place for all, and everyone is expected to take responsibility for safety. We have common targets and strive for continuous improvement. Fortum has indirect responsibility for its supply chain. We conduct business with viable companies that act responsibly and comply with the Fortum Code of Conduct and Supplier Code of Conduct. Social responsibility also includes being a good corporate citizen and taking care of the community around us. We believe that our innovations and the secure supply of low-carbon power and heat will enable social development and increase overall well-being.

A.1.1. Eligibility of the project under Gold Standard

>>

The project activity meets the eligibility criteria as per section 3.1.1 of GS4GG Renewable-Energy-Activity-Requirements document as described below.

Eligibility Criteria Category	Description	Justification	Criterion met?
Types of Projects	The project type is a large-scale Solar Power Plant which generates power using Solar Energy. The project activity belongs to the type of Renewable energy that generate and deliver power to the Indian grid.	The Solar Power Plant Project is conceived as a grid connected solar power plant within the category of renewable energy supply. See section A.1.	Yes

	The project applies methodology ACM0002 Version 20. which is an approved methodology under Gold Standard.		
Location of Project:	The Project activity will be located in Bhadla, Rajasthan. Further details have been provided in section A.4 of this report.	The Power purchase agreement between PP and NTPC.	Yes
Project Area, Project Boundary and Scale:	Project Area and Boundary are defined in line with the applicable Methodology ACM0002 Version 20. The project activity includes 70 MW installed capacity and is greenfield large scale solar power plants with an installed capacity above 15 MW to be qualified as a large-scale solar plant (in accordance with UNFCCC rules).	The Project is located at Bhadla, Rajasthan. The project has an installed capacity of 70 MW which is More than 15 MW, therefore applies as a large-Scale project. See section A.1	Yes
Host Country Requirements:	The project activity follows the Social wellbeing, Environmental wellbeing, Economic wellbeing and Technological wellbeing.	Projects is in compliance with India's legal, environmental, ecological and social regulations.	Yes
Contact Details:	Project Participant: Fortum FinnSurya Energy Pvt. Ltd. Name of the contact person: Mr. Atishay Jain Email: atishay.jain@fortum.com	GS4GG-Cover Letter	
Legal Ownership and Other Rights:	The project activity is developed by the PPs	The PPA is in the name of Fortum FinnSurya Energy Pvt. Ltd. Limited and has been submitted to the DOE. Name of the contact person: Mr. Atishay Jain Email: atishay.jain@fortum.com	Yes
Official Development Assistance (ODA) Declaration:	The project had private funding and funding from bank. The PP hereby confirms that there is no public funding from Annex 1 countries and no diversion of Official Development	The Project Owner declares that the project has not directly or indirectly received or benefited from official development assistance.	Yes

	Assistance (ODA) involved in the project activity. The project is funded by bank.		
--	--	--	--

A.1.2. Legal ownership of products generated by the project and legal rights to alter use of resources required to service the project

>>

Fortum FinnSurya Energy Pvt. Ltd. is Project Participant of the proposed project activity.

A.2 Location of project

>>

Host party: India

Region/State/Province: Rajasthan

Village: Bhadla

District: Jodhpur

Project Participants Name	Latitude	Longitude	Date of Commissioning
Fortum FinnSurya Energy Pvt. Ltd.	N 27° 28' 7.00"	E 71° 58' 17.00"	31/03/2017

Item	Description
District Headquarter	Jodhpur
Nearest Airport	Jodhpur, (227 km, 4 hrs drive)
Nearest railway station	Phalodi (83 km)
Road	National Highway
Nearest Port	Kandla (~800 km)
Water resource	Indira Gandhi Nahar Canal (2 km)



The location of the project activity as visible in the Google maps is shown below:



A.3 Technologies and/or measures

>>

Sectoral Scope: 01 - Energy industries (renewable / non-renewable sources)

Project Type: I - Renewable Energy Projects

Project Category: ACM0002: Grid-connected electricity generation from renewable sources- Version 20.0

Technical detail of the equipment	Remark
Technology	Solar PV Module
Solar photovoltaic module	First solar series 4TM PV Module
No of Modules	112.5Wp: - 88800, 115Wp: -587000, 117.5Wp: - 85200
Make	First Solar
Capacity	112.5Wp, 115Wp,117.5Wp
No of inverters	70
Capacity	1000KVA
No. of transformers	18 (ITD) + 2 (PT)
Technical & Operational Lifetime	25 years

The data to be monitored includes the electricity exported to the grid and electricity imported from the grid, which is measured by Main & Check meters installed at the substation.

The project activity results in displacing the grid power, thus resulting in reduction of CO₂ emissions that would have occurred at fossil fuel fired power plants connected to the Indian grid in the baseline scenario. The baseline scenario for the project activity is “electricity delivered to the grid by the project activity that otherwise would have been generated by the operation of grid- connected power plants and by the addition of new generation sources”. Thus, the project activity provides the same type and levels of service as would have been provided in the baseline scenario.

Solar energy is a pollution-free sustainable form of energy. It does not produce greenhouse gases in its operation, and it does not produce toxic or radioactive waste. Therefore, the technology for the project is environmentally safe and sound. It is procured from world’s renowned manufacturers. Further, there is no technology transfer associated with the project activity.

A.4 Scale of the project

>>

Renewable energy project activities with a maximum output capacity of 15 megawatts (or an appropriate equivalent) are small scale project activity and project activities of more than 15 MW are considered as large-scale CDM project activity.

As the project activity is of 70MW capacity, hence clearly it is large Scale project.

A.5 Funding sources of project

>>

The PP hereby confirms that there is no public funding from Annex 1 countries and no diversion of Official Development Assistance (ODA) involved in the project activity.

SECTION B. APPLICATION OF APPROVED GOLD STANDARD METHODOLOGY (IES) AND/OR DEMONSTRATION OF SDG CONTRIBUTIONS

B.1. Reference of approved methodology (ies)

>>

Title: Grid-connected electricity generation from renewable sources²

Reference: The project activity meets the eligibility criteria of large-scale project as it is more than 15MW

Methodology: ACM0002: Grid-connected electricity generation from renewable sources --- Version 20.0³

Type I: Energy industries (renewable / non-renewable sources)

Category: Approved Consolidated Methodology (ACM0002)

Tools referred with above methodology and applicable for project activity are:

- Tool to calculate the emission factor for an electricity system - Version 07.0 (EB 100, Annex 4)
- Tool for the demonstration and assessment of additionality 7- Version 07.0.0 (EB 70, Annex 08)
- Assessment of the validity of the original/current baseline and update of the baseline at the renewal of the crediting period – Version 03.0.1 (EB 66, Annex 47)

B.2. Applicability of methodology (ies)

>>

The project activity involves generation of grid connected electricity from renewable solar energy. The project activity has an installed capacity of 70 MW (AC) which qualifies for a large project activity under Type-I of the large-scale methodologies. The project status is corresponding to the methodology ACM0002 version 20.0 and applicability of methodology are discussed below.

Applicability Criterion	Project Case
-------------------------	--------------

² <http://cdm.unfccc.int/methodologies/PAmethodologies/approved>

³ <http://cdm.unfccc.int/methodologies/DB/8W400U6E7LFHHYH2C4JR1RJWWO4PVN>

<p>1) This methodology is applicable to grid connected renewable energy power generation project activities that:</p> <ul style="list-style-type: none"> a) Install a Greenfield power plant; b) Involve a capacity addition to (an) existing plant(s); c) Involve a retrofit of (an) existing operating plants/units; d) Involve a rehabilitation of (an) existing plant(s)/unit(s); or 	<p>The project activity is a Renewable Energy Project i.e. Solar Power Project which falls under applicability criteria option 1 (a) i.e., "Install a Greenfield power plant". Hence the project activity meets the given applicability criterion.</p>
<p>2) The methodology is applicable under the following conditions:</p> <ul style="list-style-type: none"> a) The project activity may include renewable energy power plant/unit of one of the following types: hydro power plant/unit with or without reservoir, wind power plant/unit, geothermal power plant/unit, solar power plant/unit, wave power plant/unit or tidal power plant/unit; b) In the case of capacity additions, retrofits, rehabilitations or replacements (except for wind, solar, wave or tidal power capacity addition projects) the existing plant/unit started commercial operation prior to the start of a minimum historical reference period of five years, used for the calculation of baseline emissions and defined in the baseline emission section, and no capacity expansion, retrofit, or rehabilitation of the plant/unit has been undertaken between the start of this minimum historical reference period and the implementation of the project activity. 	<p>The option (a) of applicability criteria 2 is applicable as project is renewable energy solar power plant/unit.</p>

<p>3) In case of hydro power plants, one of the following conditions shall apply:</p> <ul style="list-style-type: none"> a) The project activity is implemented in existing single or multiple reservoirs, with no change in the volume of any of the reservoirs; or b) The project activity is implemented in existing single or multiple reservoirs, where the volume of the reservoir(s) is increased and the power density, calculated using equation (7), is greater than 4 W/m²; or c) The project activity results in new single or multiple reservoirs and the power density, calculated using equation (7), is greater than 4 W/m²; or d) The project activity is an integrated hydro power project involving multiple reservoirs, where the power density for any of the reservoirs, calculated using equation (7), is lower than or equal to 4 W/m², all of the following conditions shall apply: <ul style="list-style-type: none"> e) The power density calculated using the total installed capacity of the integrated project, as per equation (8), is greater than 4 W/m²; <ul style="list-style-type: none"> i) Water flow between reservoirs is not used by any other hydropower unit which is not a part of the project activity; ii) Installed capacity of the power plant(s) with power density lower than or equal to 4 W/m² shall be: <ul style="list-style-type: none"> iii) Lower than or equal to 15 MW; and <p>Less than 10 per cent of the total installed capacity of integrated hydro power project.</p>	<p>The project is installation of new solar based electricity generation plants (not a hydro power plant). Hence this criterion is not applicable.</p>
--	--

<p>4) In the case of integrated hydro power projects, project proponent shall:</p> <ul style="list-style-type: none"> a) Demonstrate that water flow from upstream power plants/units spill directly to the downstream reservoir and that collectively constitute to the generation capacity of the integrated hydro power project; or b) Provide an analysis of the water balance covering the water fed to power units, with all possible combinations of reservoirs and without the construction of reservoirs. The purpose of water balance is to demonstrate the requirement of specific combination of reservoirs constructed under CDM project activity for the optimization of power output. This demonstration has to be carried out in the specific scenario of water availability in different seasons to optimize the water flow at the inlet of power units. Therefore, this water balance will take into account seasonal flows from river, tributaries (if any), and rainfall for minimum of five years prior to the implementation of the CDM project activity 	<p>The project is installation of new solar based electricity generation plants (not a hydro power plant). Hence this criterion is not applicable.</p>
<p>5) The methodology is not applicable to:</p> <ul style="list-style-type: none"> a) Project activities that involve switching from fossil fuels to renewable energy sources at the site of the project activity, since in this case the baseline may be the continued use of fossil fuels at the site; b) Biomass fired power plants/units. 	<p>The project activity is a greenfield project and is installation of new solar based electricity generation plants. Hence this does not fall under either category.</p>

<p>6) In the case of retrofits, rehabilitations, replacements, or capacity additions, this methodology is only applicable if the most plausible baseline scenario, as a result of the identification of baseline scenario, is “the continuation of the current situation, that is to use the power generation equipment that was already in use prior to the implementation of the project activity and undertaking business as usual maintenance”.</p>	<p>Not Applicable since this solar project is a Green field project activity and this project is not the enhancement or up gradation project.</p>
<p>7) In addition, the applicability conditions included in the tools referred to below apply.</p>	<p>Please refer tables below.</p>

Tool to calculate the emission factor for an electricity system - Version 07.0 (EB 100 annex 4)

<p>Applicability Criterion</p>	<p>Project Case</p>
<p>1) This tool may be applied to estimate the OM, BM and/or CM when calculating baseline emissions for a project activity that substitutes grid electricity that is where a project activity supplies electricity to a grid or a project activity that results in savings of electricity that would have been provided by the grid (e.g. demand-side energy efficiency projects).</p>	<p>The project is a grid connected Greenfield Solar power project and thus the tool is applicable.</p>

<p>2) Under this tool, the emission factor for the project electricity system can be calculated either for grid power plants only or, as an option, can include off-grid power plants. In the latter case, two sub-options under the step 2 of the tool are available to the project participants, i.e. option IIa and option IIb. If option IIa is chosen, the conditions specified in "Appendix 1: Procedures related to off-grid power generation" should be met. Namely, the total capacity of off-grid power plants (in MW) should be at least 10 per cent of the total capacity of grid power plants in the electricity system; or the total electricity generation by off-grid power plants (in MWh) should be at least 10 per cent of the total electricity generation by grid power plants in the electricity system; and that factors which negatively affect the reliability and stability of the grid are primarily due to constraints in generation and not to other aspects such as transmission capacity.</p>	<p>Steps involved in calculation of Emission Factor is included in PDD as per the requirement of the tool</p>
<p>3) In case of CDM projects the tool is not applicable if the project electricity system is located partially or totally in an Annex I country.</p>	<p>Project is located in non-Annex I country and hence the tool is applicable</p>
<p>4) Under this tool, the value applied to the CO₂ emission factor of biofuels is zero.</p>	<p>The project is a Solar project and there is no involvement of biofuels.</p>

Tool for the demonstration and assessment of additionality- Version 07.0.0 (EB 70, Annex 08)

Applicability Criteria has been demonstrated in section on additionality below.

The project activity qualifies as Type I during every year of the crediting period in accordance with applicable provisions for project activity eligibility as discussed above. Also, the total installed capacity of project activity is 70 MW which is applicable as per large scale project activities methodology ACM0002: Grid-connected electricity generation from renewable sources Version 20.0. The project capacity will be always remaining the same and hence the project activity will always be large scale project activities throughout the crediting period and thereafter.

B.3. Project boundary

>>

As per ACM002 version 20 - "The spatial extent of the project boundary includes the project power plant and all power plants connected physically to the electricity system that the CDM project power plant is connected to".

The project boundary includes the solar project, sub-stations, grid and all power plants connected to grid. The proposed project activity is evacuating power to the Indian grid. Therefore, the entire Indian grid and all connected power plants have been considered in the project boundary for the proposed CDM project activity.

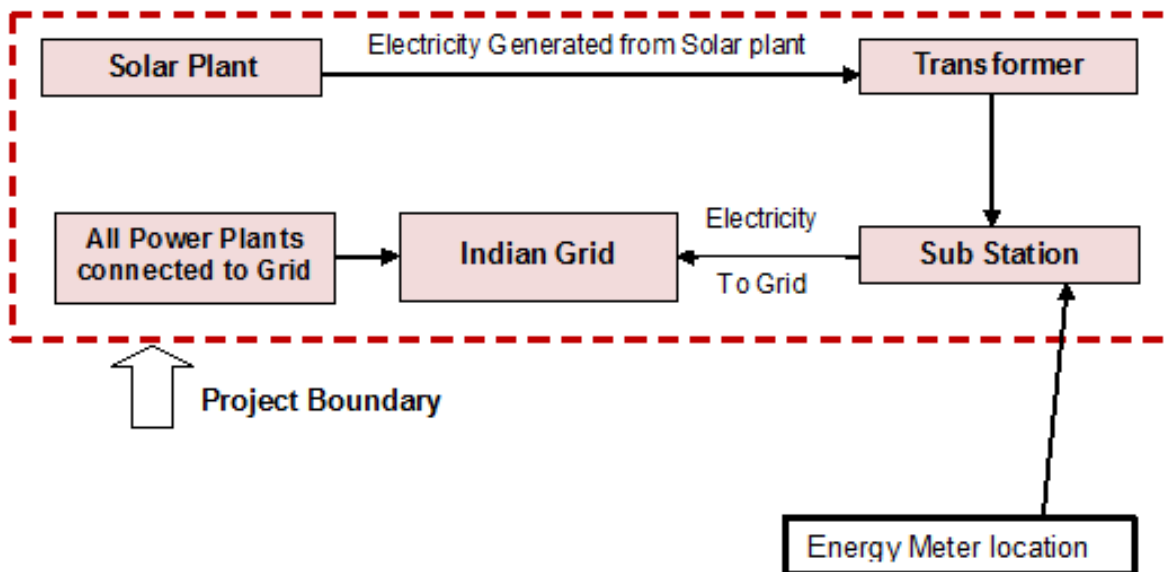

The GHG emission sources considered for the project boundary and their explanations are as follows:

Source		GHGs	Included?	Justification/Explanation
Baseline	Grid connected electricity generation	CO ₂	Yes	Main emission source
		CH ₄	No	Minor emission source
		N ₂ O	No	Minor emission source
Project	Greenfield Solar PV Power Project Activity.	CO ₂	No	No CO ₂ emissions are emitted from the project
		CH ₄	No	Project activity does not emit CH ₄
		N ₂ O	No	Project activity does not emit N ₂ O

B.4. Establishment and description of baseline scenario

>>

As per tool 11 “Assessment of the validity of the original/current baseline and update of the baseline at the renewal of the crediting period”

Step 1: Assess the validity of the current baseline for the next crediting period

Step 1.1: Assess compliance of the current baseline with relevant mandatory national and/or sectoral policies

The baseline scenario remains unchanged and is in compliance with all the relevant mandatory national and/or sectoral policies

Step 1.2: Assess the impact of circumstances

The baseline scenario identified at the validation of the project activity was “The electricity delivered to the grid by the project activity would have otherwise been generated by the operation of grid connected power plants and by the addition of new generation sources into the grid”. Thus, this project activity was a voluntary investment which intends to replace equivalent amount of electricity at grid from renewable source. PD was not bound to incur this investment; hence absence of project activity (i.e., the investment) does not lead to any continued baseline practice for PD within their scope whereas the continued operation of the project activity would continue to replace equivalent amount of electricity at grid. Hence, the same baseline as identified in the previous crediting period is still valid for the project. Therefore, the assessment of the changes in market characteristics is not required for the renewal of the project's crediting period under CDM.

Step 1.3: Assess whether the continuation of the use of current baseline equipment(s) or an investment is the most likely scenario for the crediting period for which renewal is requested.

As explained in step 1.2, the baseline scenario was the electricity import/generation from the power plants connected to the electricity grid. The project activity in green field project and there is not any baseline equipment or investment involved in project activity. Therefore, this condition is not applicable to the project activity.

Step 1.4: Assessment of the validity of the data and parameters

This step stipulates that “Where emission factors, values or emission benchmarks are used and determined only once for the crediting period, they should be updated, except if the emission factors, values or emission benchmarks are based on the historical situation at the site of the project activity prior to the implementation of the project and cannot be updated because the historical situation does not exist anymore as a result of the CDM project activity.” In the context of the present project activity the emission factor has been updated along with the approach used to calculate the emission factor

Step 2: Update the current baseline and the data and parameters

As evident from the explanation provided above the baseline scenario remains unchanged. Only the approach used to calculate the baseline emission factor is updated as per the latest version of database available at the time of PDD submission for renewal. In line with the project standard version 03.0, the impact of new relevant national and/or sectoral policies and circumstances on the baseline taking into account relevant EB guidance with regard to renewal of the crediting period at the time of requesting renewal of crediting period; and the correctness of the application of an approved baseline methodology for the determination of the continued validity of the baseline or its update, and the estimation of emission reductions for the applicable crediting period.

As per the approved consolidated Methodology ACM0002 (Version 20.0, EB 105, Annex 3) para 22: If the project activity is the installation of a Greenfield power plant, the baseline scenario is electricity delivered to the grid by the project activity would have otherwise been generated by the operation of grid-connected power plants and by the addition of new generation sources, as reflected in the combined margin (CM) calculations described in “TOOL07: Tool to calculate the emission factor for an electricity system”.

The project activity involves setting up of solar projects to harness the power of sun to produce electricity and supply to the grid. In the absence of the project activity, the equivalent amount of power would have been supplied by the Indian grid, which is fed mainly by fossil fuel fired plants. Hence, the baseline for the project activity is the equivalent amount of power from the Indian grid.

The combined margin ($EF_{grid, CM,y}$) is the result of a weighted average of two emission factor pertaining to the electricity system: the operating margin (OM) and build margin (BM). Calculations for this combined margin must be based on data from an official source (where available) and made publicly available. The CEA database version 17 was the latest available data at the time of PDD submission to DOE for validation, hence same is considered for emission factor calculations.

The combined margin of the Indian grid used for the project activity is as follows:

Parameter	Value	Nomenclature	Source
-----------	-------	--------------	--------

EF _{grid,CM,y}	0.9305 tCO ₂ /MWh	Combined margin CO ₂ emission factor for the project electricity system in year y	Calculated as the weighted average of the operating margin (0.75) & build margin(0.25) values, sourced from Baseline CO ₂ Emission Database, Version 17.0 , Oct 2021 published by Central Electricity Authority (CEA), Government of India
EF _{grid,OM,y}	0.9522 tCO ₂ /MWh	Operating margin CO ₂ emission factor for the project electricity system in year y	Calculated as the last 3 year (2018-19. 2019-20 and 2020-21) generation-weighted average, sourced from Baseline CO ₂ Emission Database, Version 17.0, October 2021 published by Central Electricity Authority (CEA), Government of India
EF _{grid,BM,y}	0.8653 tCO ₂ /MWh	Build margin CO ₂ emission factor for the project electricity system in year y	Baseline CO ₂ Emission Database, Version 17.0. Oct 2021 published by Central Electricity Authority (CEA), Government of India

B.5. Demonstration of additionality

>>

The project is retroactive and is registered under CDM; hence additional. The same can be referred from the registered CDM PDD⁴.

B.5.1 Prior Consideration

>>

There is no design change in the project. The project is undergoing renewal of crediting period. During registration of the project under CDM host country approval was taken. The date chronology for the project is as follows:

Local Stakeholder Consultation	25/05/2016
Start Date of Project Activity	29/07/2016
Host Country Approval	24/05/2017

⁴ <https://cdm.unfccc.int/Projects/DB/Applus1506003422.59/view>

CDM Registration Date	06/11/2017
Commissioning Date	31/03/2017
Date of Design Certification	03/01/2018
Date of Transition Renewable from GSCER to GSVER	02/05/2022

B.5.2 Ongoing Financial Need

>>

In line with the guidance, this information need only for those projects that are required to demonstrate financial additionality. The project activity has demonstrated the additionality at the time of project registration for 25 years of life of the project. The IRR of the project is 5% whereas the benchmark is 15.28%. Hence, the project is justifying the ongoing financial need from the Carbon revenue. Since the commissioning of project, carbon revenues are obtained which supported the project. Hence, the carbon revenue derived from project activity have been playing an important role in helping project owner in operating the project and contributing to SDGs, e.g providing renewable electricity, employment and decent work and integrating to climate change measures.

B.6. Sustainable Development Goals (SDG) outcomes

Relevant Target/Indicator for each of the three SDGs

Sustainable Development Goals Targeted	Most relevant SDG Target	SDG Impact
		Indicator (Proposed or SDG Indicator)
13 Climate Action (mandatory)	13.2: Integrate climate change measures into national policies, strategies and planning	Emission reductions in tCO ₂
SDG 7 – Affordable and Clean Energy: Ensure access to affordable, reliable, sustainable and modern energy for all	7.2 -By 2030, increase substantially the share of renewable energy in the global energy mix	Electricity produced and supplied to the grid

<p>SDG 8 – Decent Work and Economic Growth: Promote inclusive and sustainable economic growth, employment, Income Generation and decent work for all</p>	<p>8.5 - By 2030, achieve full and productive employment and decent work for all women and men, including for young people and persons with disabilities, and equal pay for work of equal value</p>	<p>10 people employed and more than 1 training will be conducted and The income to all the unskilled workers are made on day-to-day basis better than the minimum wage requirements: 357 INR</p>
--	---	--

B.6.1 Explanation of methodological choices/approaches for estimating the SDG Impact

>>

<p>SDG Goal</p>	<p>Methodological choices/approaches for estimating the SDG outcome</p>
<p>SDG 7 – Affordable and Clean Energy: Ensure access to affordable, reliable, sustainable and modern energy for all</p>	<p>Measurement Method: - Electricity produced and supplied to the grid is monitored through energy meter. Net electricity will be calculated by state electricity board and O&M operator on monthly basis and provided in the share certificate/monthly report or equivalent. The other parameters used for net electricity supplied to grid are mentioned in monitoring plan.</p>
<p>SDG 8 – Decent Work and Economic Growth: Promote inclusive and sustainable economic growth, employment, income generation and decent work for all</p>	<p>Measurement Method: - Training and employment generation is monitored through training records, staff register or letter from O&M contractor for training, income generation and employment details or HSE/HR records.</p> <p>QA/QC Process: This parameter is based on records, data and no any QA/QC procedure required. The DOE can confirm this parameter with interview with PP or Site incharge or employees for training, income generation and employment generation.</p>

<p>SDG 13 – Climate Action : Take urgent action to combat climate change and its impacts</p>	<p>Measurement Method: - The emission reduction parameter is calculated as product of net electricity supplied to grid and grid emission factor. The grid emission factor is ex-ante parameter and determined based on data obtained from “CO2 Baseline Database for Indian Power Sector” version 17, published by the Central Electricity Authority, Ministry of Power, Government of India. This is in line with “Tool to calculate the emission factor for an electricity system, version 7”</p> <p>The emission reductions are calculated as per registered PDD and as per methodology requirement.</p> <p>QA/QC Process: This parameter is calculated, and no QA/QC procedure required.</p>
---	--

B.6.2 Data and parameters fixed ex ante

SDG13

Data/parameter	EF _{grid,OM,y}
Unit	tCO ₂ /MWh
Description	Operating Margin CO ₂ emission factor in year y
Source of data	Calculated from CEA database, Version 17, October 2021
Value(s) applied	0.9522
Choice of data or Measurement methods and procedures	Calculated as per “Tool to calculate the emission factor for an electricity system, version 07” as 3-year generation weighted average using data for the years 2018-19, 2019-20, & 2020-21. The data are obtained from “CO2 Baseline Database for Indian Power Sector” version 17, published by the Central Electricity Authority, Ministry of Power, Government of India.
Purpose of data	For the calculation of the Baseline Emission

Additional comment	This parameter is fixed ex-ante for the entire crediting period.
--------------------	--

Data/parameter	$EF_{grid,BM,y}$
Unit	tCO2/MWh
Description	Build Margin CO2 emission factor in year y
Source of data	Calculated from CEA database, Version 17, October 2021
Value(s) applied	0.8653
Choice of data or Measurement methods and procedures	Calculated as per "Tool to calculate the emission factor for an electricity system, version 07". As such the latest value of build margin, 2020-21 is taken. The data are obtained from "CO2 Baseline Database for Indian Power Sector" version 17, published by the Central Electricity Authority, Ministry of Power, Government of India.
Purpose of data	For the calculation of the Baseline Emission
Additional comment	This parameter is fixed ex-ante for the entire crediting period.

Data/parameter	$EF_{grid,y}$
Unit	tCO2/MWh
Description	Combined Margin CO2 emission factor in year y
Source of data	Calculated from CEA database, Version 17, October 2021
Value(s) applied	0.9305
Choice of data or Measurement methods and procedures	<p>The combined margin emissions factor is calculated as follows: $EF_{grid,CM,y} = EF_{grid,OM,y} * W_{OM} + EF_{grid,BM,y} * W_{BM}$</p> <p>Where:</p> <p>$EF_{grid,BM,y}$ = Build margin CO2 emission factor in year y (tCO2/MWh)</p>

	<p>$EF_{grid,OM,y}$ = Operating margin CO2 emission factor in year y (tCO₂/MWh)</p> <p>W_{OM} = Weighting of operating margin emissions factor (%) = 75%</p> <p>W_{BM} = Weighting of build margin emissions factor (%) = 25%</p>
Purpose of data	For the calculation of the Baseline Emission
Additional comment	This parameter is fixed ex-ante for the entire crediting period.

B.6.3 Ex ante estimation of SDG Impact

>>

SDG 7: Affordable and Clean Energy- Project expected to generate 121,420 MWh clean energy every year

SDG 8: Decent Work and Economic Growth- Minimum 1 training to be carried out annually, apart from providing employment to 10 persons for income generation.

SDG13: Climate Action- The project leads to mitigation of 112,980 tCO₂ per annum.

Baseline Emissions BE_y

As per the approved consolidated Methodology ACM0002 (Version 20.0, EB 105, Annex 03), Emission reductions are calculated as follows:

$$ER_y = BE_y - PE_y$$

Where:

ER_y = Emission reductions in year y (t CO₂e/yr)

BE_y = Baseline emissions in year y (t CO₂e/yr)

PE_y = Project emissions in year y (t CO₂e/yr)

Baseline Emissions:

Baseline Emissions for the amount of electricity supplied by project activity, BE_y is calculated as

$$BE_y = EG_{PJ,y} \times EF_{grid,CM,y}$$

Where:

BE_y = Baseline emissions in year y (t CO₂/yr)

$EG_{PJ,y}$ = Quantity of net electricity generation that is produced and fed into the grid as a result of the implementation of the CDM project activity in year y (MWh/yr)

$EF_{grid,CM,y}$ = Combined margin CO₂ emission factor for grid connected power generation in year y calculated using the latest version of the "Tool to calculate the emission factor for an electricity system" (t CO₂/MWh).

Using the values for operating and build margin emission factor provided in the CEA database and their respective weights for calculation of combined margin emission factor, the baseline carbon emission factor (CM) is 0.9305 tCO₂e/MWh.

$$EG_{PJ,y} = 121,420 \text{ MWh/yr}$$

$$EF_{grid,CM,y} = 0.9305 \text{ tCO}_2/\text{MWh}$$

$$BE_y = EG_{PJ,y} \times EF_{grid,CM,y}$$

$$BE_y = 121,420 \times 0.9305 \text{ tCO}_2/\text{yr}$$

$$BE_y = 112,980 \text{ tCO}_2/\text{yr}$$

Project Emission

As per the ACM0002 ver-20.0, Project Emission for most renewable energy power generation project activities, $PE_y = 0$. However, some project activities may involve project emissions that can be significant. These emissions shall be accounted for as project emissions by using the following equation:

$$PE_y = PE_{FF,y} + PE_{GP,y} + PE_{HP,y}$$

Where:

PE_y = Project emissions in year y (tCO₂e/yr)

$PE_{FF,y}$ = Project emissions from fossil fuel consumption in year y (tCO₂/yr)

$PE_{GP,y}$ = Project emissions from the operation of geothermal power plants due to the release of non-condensable gases in year y (tCO₂e/yr)

$PE_{HP,y}$ = Project emissions from water reservoirs of hydro power plants in year y (tCO₂e/yr).

The project activity involves the generation of electricity from the installation of solar projects. Hence, as per ACM0002, Version 20.0, there is no project emission for solar projects. Therefore, project emissions are zero.

Leakage Emissions

No leakage emissions are considered in the project activity. The main emissions potentially giving rise to leakage in the context of electric sector projects are emissions arising due to activities such as power plant construction and upstream emissions from fossil fuel use (e.g. extraction, processing, transport). Since the emissions sources are small, it is neglected.

Emission Reductions

Emission reductions are calculated as follows

$$ER_y = BE_y - PE_y - LE_y$$

Where:

ER_y = Emission reductions in year y (tCO₂/y)

BE_y = Baseline emissions in year y (tCO₂/y)

PE_y = Project emissions in year y (tCO₂/y)

LE_y = Leakage emissions in year y (tCO₂/y)

$$ER_y = BE_y - PE_y - LE_y$$

$$ER_y = 112,980 - 0 - 0$$

$$ER_y = 112,980 \text{ (tCO}_2\text{/y)}$$

For ER estimation, 0.5% degradation factor per year is applied from second year and emission reductions are determined as mentioned in the section below.

B.6.4 Summary of ex ante estimates of each SDG Impact

SDG 7: Affordable and Clean Energy

Year	Baseline estimate	Project estimate	Net benefit
Year 1	0	122,640	122,640
Year 2	0	122,027	122,027
Year 2	0	121,417	121,417
Year 4	0	120,810	120,810
Year 5	0	120,206	120,206
Total	0	607,099	607,099
Total number of crediting years	5		

Annual average over the crediting period	0	121,420	121,420
---	----------	----------------	----------------

SDG13: Climate Action

Year	Baseline estimate	Project estimate	Net benefit
Year 1	114,116	0	114,116
Year 2	113,545	0	113,545
Year 2	112,978	0	112,978
Year 4	112,413	0	112,413
Year 5	111,851	0	111,851
Total	564,903	0	564,903
Total number of crediting years	5		
Annual average over the crediting period	112,980		112,980

SDG 8: Decent Work and Economic Growth

Year	Baseline estimate	Project estimate	Net benefit
Year 1	0 Training, 0 Jobs, 0 income generation	1 Training, 10 Jobs, income better than the minimum wage.	1 Training, 10 Jobs, income better than the minimum wage.
Year 2	0 Training, 0 Jobs, 0 income generation	1 Training, 10 Jobs, income better than the minimum wage.	1 Training, 10 Jobs, income better than the minimum wage.
Year 2	0 Training, 0 Jobs, 0 income generation	1 Training, 10 Jobs, income better than the minimum wage.	1 Training, 10 Jobs, income better than the minimum wage.
Year 4	0 Training, 0 Jobs, 0 income generation	1 Training, 10 Jobs, income better than the minimum wage.	1 Training, 10 Jobs, income better than the minimum wage.

Year 5	0 Training, 0 Jobs, 0 income generation	1 Training, 10 Jobs, income better than the minimum wage.	1 Training, 10 Jobs, income better than the minimum wage.
Total	0 Training, 0 Jobs, 0 income generation	1 Training, 10 Jobs, income better than the minimum wage.	1 Training, 10 Jobs, income better than the minimum wage.
Total number of crediting years	5		
Annual average over the crediting period	0 Training, 0 Jobs, 0 income generation	1 Training, 10 Jobs, income better than the minimum wage.	1 Training, 10 Jobs, income better than the minimum wage.

B.7. Monitoring plan

>>

B.7.1 Data and parameters to be monitored

SDG 7: Affordable and Clean Energy

Data / Parameter	EG _{PJ,y}
Unit	MWh/y
Description	Quantity of net electricity generation supplied by the project plant/unit to the grid in year y in MWh
Source of data	Monthly joint meter reading reports (70MW)
Value(s) applied	121,420 (Estimated Value)
Measurement methods and procedures	<p>Plant end dedicated metering: The electricity exported / supplied by the plant is first metered by plant end dedicated meter. This can be considered as stand by meter.</p> <p>Common metering at the substation: All the plants (including the project activity solar plant and other investors solar plant) are further connected to a common metering point at Pooling substation 132/220 KV GSS II</p>

	<p>and further electricity is transferred to 220/400 KV RRVPNL substation. The common metering point consists of both main & check meters (ABT Meters) having accuracy class of 0.2s. The export/import losses between these two substations are apportioned based on pooling substation readings.</p> <p>The difference of final apportioned value of export and import is used for monthly values of net electricity supplied to the grid by the project activity and same value will be considered for ER calculations.</p>
Monitoring frequency	Continuous measurement & monthly recording
QA/QC procedures	<p>The meters are approved, tested & sealed by the State Utility. The meters are in the custody of State Utility. The frequency of calibration is once in 5 years. The monthly electricity supplied/exported by the project activity in the JMR report is cross checked with the monthly invoices of sale. In the absence or delay in the meter calibration appropriate Guidelines will be applied appropriately to confirm the conservativeness of metering.</p> <p>The metering arrangement, accuracy class of meters, calibration frequency and apportioning approach is under control of state electricity board and PP do not have any control on it. PP is getting value of net electricity supplied to grid and the same is considered the monitoring parameter.</p>
Purpose of data	Calculation of baseline emissions
Additional comment	Data will be archived in paper & electronic form for two years after the end of crediting period or of the last issuance of VERs for this project activity, whichever occurs later.

SDG 8: Decent Work and Economic Growth

Data / Parameter	Quantitative employment and income generation
Unit	Number
Description	Number of people employed directly due to the project activity. Number of men and number of women employed by the project activity.

	Type of job like temporary/permanent or skilled/unskilled, etc. are also monitored and it is ensured that peoples will get equal payment for equal work.
Source of data	Plant records / Letter from O&M contractor for employment generation/ DOE interview with employees, local stakeholders etc
Value(s) applied	10
Measurement methods and procedures	<p>The total number of persons working in the plant would be calculated based on the daily log available at site. This parameter also monitors number of men/women employed by the project activity. The project activity ensures that "equal pay for work of equal value" for both men and women and there is no discrimination of any kind against women.</p> <p>"The employment covers number of men and number of women employed by the project activity. The job is of type temporary/permanent or skilled/unskilled, etc. Also, it is ensured that peoples will get equal payment for equal work. The payment will be based on work and no gender inequality for payment for work of equal value.</p> <p>The employment generated refers to overall jobs created during project implementation and during project Operation and Maintenance. This is primary and direct effect on employment generated due to project activity. The effect of employment generation is not 'one off' or an effect generated in design, construction, distribution or start-up or decommissioning of the Project."</p>
Monitoring frequency	Monthly monitoring and annual compilation
QA/QC procedures	The number of persons employed would be mentioned in the plant register, which can be crossed checked with daily attendance register.
Purpose of data	To Monitor the SDG 8 Indicator
Additional comment	-

SDG 8 : Decent Work and Economic Growth

Data / Parameter	Quality of employment
Unit	-
Description	Training of staff

Source of data	The training records for all the employees/Letter from O&M contractor for employment generation/ DOE interview with employees, local stakeholders etc
Value(s) applied	1 training per year
Measurement methods and procedures	Together with the technology supplier, the Project organize training for the staff on the technology and the monitoring of the plant operation, and the emergency and safety procedures.
Monitoring frequency	Annually
QA/QC procedures	The training records for all the employees
Purpose of data	To Monitor the SDG 8 Indicator
Additional comment	-

SDG13: Climate Action

Data / Parameter	ER y
Unit	tCO2/year
Description	Emission reductions achieved per year
Source of data	Calculated as per registered PDD and as per methodology
Value(s) applied	112,980
Measurement methods and procedures	The baseline emissions are the product of electrical energy baseline $EG_{P,J,y}$ expressed in MWh of electricity produced by the renewable generating unit multiplied by an emission factor.
Monitoring frequency	As per monitoring period
QA/QC procedures	Not Applicable
Purpose of data	Calculation of emission reductions
Additional comment	Data will be archived in paper & electronic form for two years after the end of crediting period or of the last issuance of CERs for this project activity, whichever occurs later.

B.7.2 Sampling plan

>>

Not Applicable

B.7.3 Other elements of monitoring plan

>>

The monitoring plan is developed in accordance with the modalities and procedures for CDM project activities and is proposed for grid-connected solar power project being implemented in Rajasthan, India. The monitoring plan, which is implemented by the project participant describes about the monitoring organization, parameters to be monitored, monitoring practices, quality assurance, quality control procedures, data storage and archiving.

The authority and responsibility for registration, monitoring, measurement, reporting and reviewing of the data rests with the project participant. PP proposed the following structure for data monitoring, collection, data archiving and calibration of equipment's for this project activity. The team comprises of the following members:

Gold Standard®

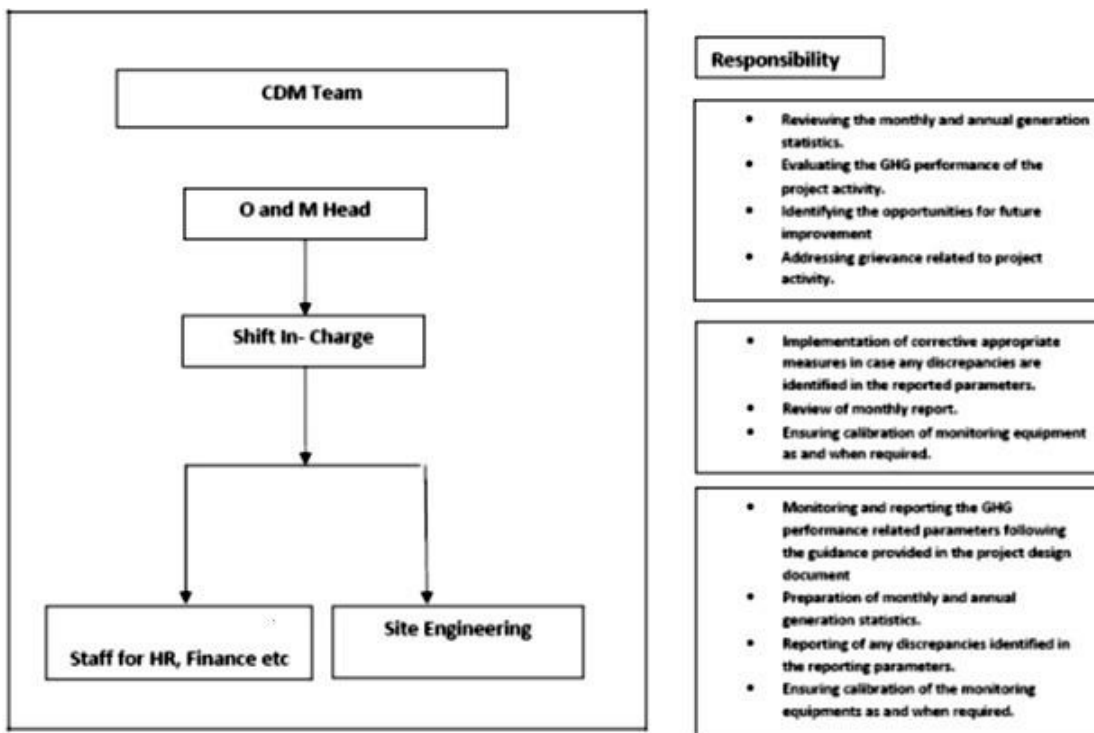

Data Measurement

The export and import energy will be measured continuously using above mentioned Main and Check meters located at the substation. Readings of meters shall be taken on monthly basis by authorized officer of SEB in the presence of PP or representative of PP. Based on the Meter Reading Statement to Fortum FinnSurya Energy Pvt. Ltd,

invoices will be raised. These invoices can be used for cross checking the meter readings taken for the respective project activity.

In case of billing cycle and monitoring period cycle does not match, then daily generation data will be used to determine net electricity export for particular period.

Data collection and archiving

Readings from meters will be collected in the presence of the plant in-charge. Export and Import data would be recorded and stored in logs as well as in electronic form on a daily basis. The records are checked periodically by the Plant Manager and discussed thoroughly with the plant supervisor. The period of storage of the monitored data will be 2 years after the end of crediting period or till the last issuance of CERs for the project activity whichever occurs later.

Emergency preparedness

The project activity will not result in any unidentified activity that can result in substantial emissions from the project activity. No need for emergency preparedness in data monitoring is visualized.

Personnel training

In order to ensure a proper functioning of the project activity and a properly monitoring of emission reductions, the staff (CDM team) will be trained. The plant helpers will be trained in equipment operation, data recording, reports writing, operation and maintenance and emergency procedures in compliance with the monitoring plan.

SECTION C. DURATION AND CREDITING PERIOD

C.1. Duration of project

C.1.1 Start date of project

>>

29/07/2016⁵

C.1.2 Expected operational lifetime of project

>>

25 Years 00 Months

C.2. Crediting period of project

C.2.1 Start date of crediting period

>>

06/11/2022⁶

C.2.2 Total length of crediting period

>>

5 Years renewable crediting period⁷

SECTION D. SUMMARY OF SAFEGUARDING PRINCIPLES AND GENDER SENSITIVE ASSESSMENT

D.1 Safeguarding Principles that will be monitored

A completed Safeguarding Principles Assessment is in [Appendix 1](#), ongoing monitoring is summarized below.

Principles	Mitigation Measures added to the Monitoring Plan
Principle 2. Gender Equality	The project proponent is committed to the employee's equal pay for equal work during all phases of the project.

⁵ As per the registered PDD, Project activity is a Retroactive Project. The same can be referred from publicly available PDD

⁶ End date of First Crediting Period is 05/11/2022, hence Start date of second crediting period 06/11/2022

⁷ As per Transition Requirements "Transition project, PoA/CPAs shall follow GS4GG certification cycle for crediting period renewal (e. g.5 years) in order to issue or convert issued emission reductions to GSVERs under GS4GG." Crediting Period under CDM is from 06/11/2017 to 05/11/2024 (Renewable)

Hence Crediting period in GS are as follows:

CP1: 06/11/2017 to 05/11/2022

CP2: 06/11/2022 to 05/11/2027 (Renewable of Crediting Period is undergoing)

	Please refer section B.7.2.1 above, same has been considered as monitoring parameter under SDG 8 (8.5.1)
Principle 6.1 Labor Rights	The Project Developer ensures the training of workers, documentation and reporting of accidents and incidents, and emergency preparedness and response measures.
Principle 9.5 Hazardous and Non-hazardous Waste	The waste will be disposed to the waste handlers and the firm will comply with all the local laws for monitoring and disposal.

D.2. Assessment that project complies with GS4GG Gender Sensitive requirements

Question 1 - Explain how the project reflects the key issues and requirements of Gender Sensitive design and implementation as outlined in the Gender Policy?	<p>Project participants do not involve and promote any discrimination about the gender differences. As per Gold Standard Gender Policy, para 13(i) “Foundational gender-sensitive requirement - This strengthens Gold Standard’s ‘do no harm’ approach and addresses safeguard to prevent or mitigate adverse impacts on women or men and girls and boys. Such action is mandatory for all projects seeking Gold Standard certification and includes compliance with the gender ‘do no harm’ safeguards, gender gap analysis and gender sensitive stakeholder consultations.”.</p> <p>The project does not seek to graduate to gender-grade GS certification and thus foundational gender sensitive requirements have been described.</p> <p>The Foundational gender-sensitive minimum standards have been demonstrated as per the below: HR Policy takes into account various gender sensitive measures such as:</p> <ol style="list-style-type: none"> 1. There is no gender pay gap and there is transparency in pay and opportunities for promotion
---	--

	<p>and advancement. There is no discrimination between employees by: (1) paying a wage to employees of one sex or gender identity at an equal rate; and (2) providing equivalent employment opportunities as defined by the law, based on sex and gender identity.</p> <p>2. There are Gender Unbiased Leave policies, working hours, compliance to minimum wage standards, no harassment policy in the organization. Thus, the project does not involve and is not complicit in any form of discrimination based on gender difference.</p>
<p>Question 2 - Explain how the project aligns with existing country policies, strategies and best practices</p>	<p>India is party to “Convention on the Elimination of All Forms of Discrimination against Women” and the project has aligned its policies which does not discriminate on gender.</p>
<p>Question 3 - Is an Expert required for the Gender Safeguarding Principles & Requirements?</p>	<p>The project does not seek to graduate to gender-grade GS certification and thus foundational gender sensitive requirements have been justified.</p> <p>As per GS4GG GENDER EQUALITY REQUIREMENTS & GUIDELINES, “Gold Standard may require that the Project seek the input of an Expert Stakeholder and to include their recommendations in the Project design. For projects seeking gender-responsive certification, the Gold Standard VVBs audit teams shall include gender consultants with relevant sector expertise to verify the gender claims of the project”. The Project participants do not involve and promote any discrimination about the gender differences. The same is ensured into HR Policy, hence no expert Stakeholder inputs are required. Further the questions raised in the Gold Standard Safeguarding</p>

	<p>Principles & Requirements document are described under Appendix 1.</p>
<p>Question 4 - Is an Expert required to assist with Gender issues at the Stakeholder Consultation?</p>	<p>No Expert is required to assist with Gender issues at the Stakeholder Consultation as the stakeholders were invited in a 'gender-sensitive' manner and efforts has been made to solicit input from women and marginalised groups.</p> <p>As per the GS Stakeholder guidelines, section 1.1.2 "All Gold Standard projects shall "take gender issues into account". This requires local stakeholder consultation processes to reach a wide range of community representatives in ways that ensure equal and effective participation of both women and men, and that gender issues are fully factored into comprehensive social and environmental impact assessments."</p> <p>The Local Stakeholder Consultation Meeting had an overall healthy participation in the meeting. It was held during the day, as women tend to circulate more freely and safely than after sunset. All the villagers were invited for the consultation through invitation pasted in public places (local administration Offices, Bus Stand, Market etc.) The meeting was conducted in local language and English translation is prepared for the purpose of reporting.</p> <p>The project representative explained how the power projects help in providing clean energy and thereby help in mitigating impacts due to Global Warming and the impacts of solar power projects which lead to providing clean energy, increase in employment opportunities both long term and short term,</p>

increased income and thereby leading to improvement in living standard of the people.

SECTION E. SUMMARY OF LOCAL STAKEHOLDER CONSULTATION

The below is a summary of the 2 step GS4GG Consultation for monitoring purposes. Please refer to the separate Stakeholder Consultation Report for a complete report on the initial consultation and stakeholder feedback round.

E.1 Summary of stakeholder mitigation measures

>>

The Local Stakeholder Meetings were organized for local stakeholder consultation and informed local stakeholder regarding the meeting. The followings are the local stakeholders for the project activity:

- Local community
- Local village administration
- Technology suppliers
- Local vendors

Date of invitation – 14/05/2016

Date of Meeting – 25/05/2016

Location of Meeting - Solar power project site Bhadla, Jodhpur - Rajasthan

All the stakeholders have been invited through public notice to attend the stakeholders meeting.

The stakeholders gathered at the venue, as per the scheduled time. The meeting was opened by Mr. Chinmay Samantha from Fortum FinnSurya Energy Pvt. Ltd. In the introductory speech, the representatives welcomed the gathering and given a brief about the CDM project activity. Subsequent to the introductory speech, stakeholders were explained about the electricity generation from solar project is an environmentally friendly power generation technology contributing to reduction in GHG emissions. They were also explained about the benefits of the solar power projects like, increasing

energy availability and improving quality of power and its assistance to the local population by providing employment opportunities to both skilled & unskilled labors.

Meeting started with opening speech by representative of project participant. He introduced all guests on dais. The representative of project participant explained technical aspects of project to stakeholders. He also explained about social, environmental & economic benefits of the project. He also elaborated about CDM & its requirement for the current project. After the presentation, the session was open for questions/feedback from stakeholders.

The villagers raised various queries as summarized below:

Q: Will the operation of the plant result in increased temperature in the surroundings?

A: There will be no impact on ambient temperature due to operation of the plant.

Q: Does the project provides employment opportunities or improve economic development of the area?

A: Yes, the project will provide economic development of the area and will provide employment opportunities to the local people depending upon their skill and qualification.

Q: Will the project help in improving the electricity supply to the villagers or neighborhood areas?

A: The electricity generated from the project shall be sold to NTPC under 25-year PPA who in turn shall sell it to state discom whose responsibility is to distribute electricity in their respective jurisdiction including surrounding villages. It is envisaged that this would improve the electricity availability situation in the neighborhood area.

Q: How the project activity benefits the villages around the project site and their residents?

A: The project activity will benefit the nearby villagers by providing employment opportunities to local or nearby people and also provides immense opportunity for economic development of the area like increase in business opportunities in the form of

works for module cleaning, hiring of vehicle etc., improvement in transportation; and various social activities shall help to uplift the standard of living.

All the above queries have been suitably and satisfactorily replied / clarified by project participant's representatives.

The stakeholder Feedback Round (SFR) was planned from 24/01/2017. The email has been sent to relevant stakeholders like NGOs, DNA officials, Gold Standard officials along with project documents.

PDD and initial GS passport made available in public domain (GS website) for 60 days to enable the local stakeholders to make comments.

The process for the SFR was as follows:

- E mail and Invitations send to relevant stakeholders
- The non-technical summary of project activity along with Registered PDD, web link of UNFCCC web page for the same registered project in CDM, draft GS passport submission to relevant stakeholders, GS Public view section web link.
- Grievance Mechanism Feedback/Questions from Stakeholders

Answers for questions received from stakeholders during online SFR process.

Identification of Stakeholders:

The Stakeholder feedback round has been planned to consider and to receive feedback from the possible stakeholders to the project, i.e. NGOs. Apart from these, the stakeholders as identified by Gold standard Board, i.e. Gold standard partnered NGOs in India and DNA of India (MoEF).

The nearby local villagers were considered for Stakeholder Feedback Round.

Invitations to Stakeholders:

The Stakeholder feedback round has been done online method. Email invitations were sent to GS partnered NGO's, GS officials, and MoEF on 24/12/2016. For local stakeholders like villagers, public notice has been put and feedback is requested for the project activity.

The Mandatory Continuous Input & Grievance Expression Methods applied are described below

The below national/international NGO Supporters have been identified for stakeholder feedback round and e mail has been sent for below NGO supporters and other stakeholders. The C and D category stakeholders are invited through online SFR. For category A and B, the public notice has been put at project site.

Organisation	Country	Name	First Name	e-mail
Carbon Watch	India	Mawandia	Deepak	deepak.mawandia@carbonwatch.com
EnerGHG India	India	Paruchuri	Narendra	narendra@energhg.in
Fair Climate Network	India	Dr. Padmanabha	Sudha	sudha@fairclimate.com
Non-Conventional Energy and Rural Development Society (NERD SOCIETY Coimbatore)	India	Mrs. Kamaraj	Sathiajothi	info@nerdsocietycoimbatore.org nerdsocietycoimbatore@hotmail.com
SKG Sangha	India	Devabhaktuni	Vidya Sagar	skgsangha@gmail.com
Winrock International India	India	Das	Debajit	debajit@winrockindia.org

The other stakeholders identified are as below

Name : Organisation
 Ayushi Jain : Gold Standard
 Neha Rao : Gold Standard
 Abhishek Bansal : Gold Standard
 Abhishek Goyal : Gold Standard

National CDM Authority: Ministry of Environment, Forest and Climate Change

The monitoring of project shall be carried out periodically and the auditors would be visiting or interviewing the stakeholders and in case any concerns the same can also be discussed with them.

DOE who has appointed as the auditor for the project, interacted with stakeholders and observe their views regarding the SFR process and the project activity.

Question/Comments session:

There are no comments received during the 2 months period of stakeholder feedback round.

E.2 Final continuous input / grievance mechanism

Method	Include all details of Chosen Method (s) so that they may be understood and, where relevant, used by readers.
Continuous Input / Grievance Expression Process Book (mandatory)	Input/Grievance Register to be maintained at project site O&M provider office. The format of receiving inputs/ complaints is as per GS requirements and is attached as annex 1.
GS Contact (mandatory)	help@goldstandard.org
Other	PP Representative Email address mentioned in the Grievance Book: Atishay Jain and his mobile number is +91 8527694527 shall be available for any stakeholder to comment. Email id: atishay.jain@fortum.com SustainCert: info@sustain-cert.com

The comments mentioned shall be recorded in the grievance register and shall be processed.

APPENDIX 1 - SAFEGUARDING PRINCIPLES ASSESSMENT

Complete the Assessment below and copy all Mitigation Measures for each Principle into [SECTION D](#) above. Please refer to the instructions in the [Guide to Completing](#) this Form.

Assessment Questions/ Requirements	Justification of Relevance (Yes/potentially/no)	How Project will achieve Requirements through design, management or risk mitigation.	Mitigation Measures added to the Monitoring Plan (if required)
Principle 1. Human Rights			

<p>1. The Project Developer and the Project shall respect internationally proclaimed human rights and shall not be complicit in violence or human rights abuses of any kind as defined in the Universal Declaration of Human Rights</p> <p>2. The Project shall not discriminate with regards to participation and inclusion</p>	<p>No</p>	<p>1) The Project is not in conflict with the economic livelihood or other issue of the local community. Thus, the Project does not cause any human rights abuse and respects internationally proclaimed human rights issue.</p> <p>2) Project activities are not expected to cause any human rights abuse. As a member of United Nations⁸ and part of UN Agreement on Human Rights⁹, it is ensured by law in India that no action can be taken against human rights. The Human Rights Policy also states that the PP will embrace the diversity of individuals, always treat one another with dignity and respect, and not engage in any acts of direct or indirect discrimination based on protected characteristics; Also, will take action when others engage in conduct that violates this policy.</p>	<p>Not Required</p>
<p>Principle 2. Gender Equality</p>			

<p>1. The Project shall not directly or indirectly lead to/contribute to adverse impacts on gender equality and/or the situation of women.</p> <p>2. Projects shall apply the principles of non-discrimination, equal treatment, and equal pay for equal work.</p> <p>3. The Project shall refer to the country’s national gender strategy or equivalent national commitment to aid in assessing gender risks</p>	<p>No</p>	<p>1) The Project do not directly or indirectly lead to/contribute to adverse impacts on gender equality and/or the situation of women. For this project, every employee is treated with respect and afforded equitable treatment. The grievance register has maintained at site to take stakeholder feedback.</p> <p>There is no any sexual harassment and/or any forms of violence against women.</p> <p>2) Projects shall apply the principles of nondiscrimination, equal treatment, and equal pay for equal work. The project has equal opportunity for both men and women.</p> <p>3) India ratified the International Convention on the Elimination of All Forms of Racial Discrimination¹⁰ on 03/12/1968 with certain reservation. The</p>	<p>Not required</p>
---	-----------	--	---------------------

⁸ <https://labour.gov.in/lcandilasdivision/india-ilo>

⁹ <https://www.ilo.org/newdelhi/lang--en/index.htm>

¹⁰ https://nhrc.nic.in/documents/india_ratification_status.pdf

<p>4. (Where required) Summary of opinions and recommendations of an Expert Stakeholder(s)</p>		<p>project activity is in line with strategy of elimination of discrimination.</p> <p>4) Summary of opinions and recommendations of an Expert Stakeholder is required in case of Gender responsive project activity.</p>	
<p>Principle 3. Community Health, Safety and Working Conditions</p>			
<p>1. The Project shall avoid community exposure to increased health risks and shall not adversely affect the health of the workers and the community.</p>	<p>No</p>	<p>1) The project proponent is committed to the employee’s workplace health & safety during all phases of the project.</p> <p>The company ensures to provide safe and healthy workplaces for employees and protecting the safety of the communities. All employees will attend health & safety trainings. This is issued in the Labor code on Occupational Safety, Health and Working Conditions and UN Agreement on Human Rights¹¹.</p>	<p>Not required</p>

¹¹ <https://www.ohchr.org/EN/Countries/AsiaRegion/Pages/INIndex.aspx>

Principle 4.1 Sites of Cultural and Historical Heritage			
Does the Project Area include sites, structures, or objects with historical, cultural, artistic, traditional or religious values or intangible forms of culture?	No	There is no designated archaeological or cultural heritage site within 10 Km radius of the study area village. Law on Cultural heritage is protected against alteration, damage or removal by the “law on cultural heritage ¹² ”.	Not Required
>>		No monument of cultural or historical importance is affected by the route of the transmission line. No cultural heritage/ indigenous people are replaced by the project.	
Principle 4.2 Forced Eviction and Displacement			
Does the Project require or cause the physical or economic relocation of	No		Not required

¹² <https://cpwd.gov.in/Publication/ConservationHertBuildings.pdf>

peoples (temporary or permanent, full or partial)?		Project activity is a solar power plant planned in the land acquired by the project activity is mostly barren land.	
>>			
Principle 4.3 Land Tenure and Other Rights			
Does the Project require any change, or have any uncertainties related to land tenure arrangements and/or access rights, usage rights or land ownership?	No	There are no uncertainties regarding land tenure, access rights, usage rights or land ownership.	Not Required
>>			
Principle 5. Corruption			
1. The Project shall not involve, be complicit in or inadvertently contribute to or reinforce corruption or corrupt Projects	No	The project is renewable energy technology and does not contribute to or reinforce corruption of any kind. The consequences for violating Anti-Corruption Laws can be severe, including significant fines, imprisonment and loss of reputation and business.	Not Required

		India has ratified UN convention against Corruption in 2011 ¹³ .	
Principle 6.1 Labour Rights			
<p>1. The Project Developer shall ensure that all employment is in compliance with national labour occupational health and safety laws and with the principles and standards embodied in the ILO fundamental conventions.</p> <p>2. Workers shall be able to establish and join labour organisations</p>	No	<p>1) The project proponent is committed to the employee's workplace health & safety during all phases of the project. All employees will attend health & safety trainings. This is issued in the Labour code on Occupational Safety, Health and Working Conditions and UN Agreement on Human Rights¹⁴.</p> <p>2) The project respects fundamental right of employee. There is law in India since 1926 by The Trade Unions Act, 1926¹⁵ which protects rights of industrial trade unions and their members. PP and appointed contractors will not involve in any form</p>	Not required

¹³ https://treaties.un.org/Pages/ViewDetails.aspx?src=IND&mtdsg_no=XVIII-14&chapter=18&clang=en#EndDec

¹⁴ <https://www.ohchr.org/EN/Countries/AsiaRegion/Pages/INIndex.aspx>

¹⁵ <http://ncw.nic.in/acts/TheTradeUnionsAct1926.pdf>

<p>3. Working agreements with all individual workers shall be documented and implemented and include:</p> <p>a) Working hours (must not exceed 48 hours per week on a regular basis), AND</p> <p>b) Duties and tasks, AND</p> <p>c) Remuneration (must include provision for payment of overtime), AND</p> <p>d) Modalities on health insurance, AND</p> <p>e) Modalities on termination of the contract with provision for voluntary resignation by employee, AND</p>		<p>of forced or compulsory labor. India has ratified ILO “C029 – Forced Labor Convention”¹⁶</p> <p>3) The working agreements with all individual workers are available which contains the guidelines that define how employees work, and the working environment to feel safe and free to learn, explore and discover.</p> <p>4) The notice at every site is displayed containing abstract of sections 3 A & 14 of The Child and Adolescent Labour (Prohibition and Regulation) Act, 1986.¹⁷</p> <p>5) The project owner is committed to the safe and healthy working conditions all phases of the project. All employees will attend trainings health</p>	
--	--	--	--

¹⁶ https://www.ilo.org/dyn/normlex/en/f?p=1000:11200:0::NO:11200:P11200_COUNTRY_ID:102691

¹⁷ The notice displayed containing abstract of sections 3 A & 14 of The Child and Adolescent Labour (Prohibition and Regulation) Act, 1986 is submitted to the DOE

<p>f) Provision for annual leave of not less than 10 days per year, not including sick and casual leave.</p> <p>4.No child labour is allowed (Exceptions for children working on their families' property requires an <u>Expert Stakeholder</u> opinion)</p> <p>5.The Project Developer shall ensure the use of appropriate equipment, training of workers, documentation and reporting of accidents and incidents, and emergency preparedness and response measures.</p>		<p>& safety. This issue is protected by Labor code¹⁸ and UN Agreement on Human Rights¹⁹.</p>	
<p>Principle 6.2 Negative Economic Consequences</p>			

¹⁸ <https://www.ohchr.org/EN/Countries/AsiaRegion/Pages/INIndex.aspx>

¹⁹ <https://www.ohchr.org/EN/Countries/AsiaRegion/Pages/INIndex.aspx>

<p>1. Does the project cause negative economic consequences during and after project implementation?</p>	<p>No</p>	<p>The project activity is a renewable solar power generation project and generates various employment opportunity for the locals throughout its lifetime. Thus, there is no negative economic consequences during and after project implementation.</p>	<p>Not Required</p>
<p>>></p>			
<p>Principle 7.1 Emissions</p>			
<p>Will the Project increase greenhouse gas emissions over the Baseline Scenario?</p>	<p>No</p>	<p>a. The project reduces Greenhouse Gas (GHG) emissions and fossil fuel usage compared to the baseline scenario.</p>	<p>Not Required</p>
<p>>></p>			
<p>Principle 7.2 Energy Supply</p>			
<p>Will the Project use energy from a local grid or power supply (i.e., not connected to a national or regional grid) or fuel resource (such as wood, biomass) that provides for other local users?</p>	<p>No</p>	<p>No. The project activity is a grid connected renewable energy based Solar power generation project. There is no use of Wood or Biomass in the project activity. On the contrary the project generates renewable energy and supplies to the grid. Hence, it's not required to be monitored.</p>	<p>Not required</p>
<p>>></p>			
<p>Principle 8.1 Impact on Natural Water Patterns/Flows</p>			

<p>Will the Project affect the natural or pre-existing pattern of watercourses, ground-water and/or the watershed(s) such as high seasonal flow variability, flooding potential, lack of aquatic connectivity or water scarcity?</p>	<p>No</p>	<p>The project being a solar power project thus there is no impact of water resources. The plant area does not have large rivers and streams, only small gaps flow. In the dry season, there is almost no water, only water in the rainy season.</p>	<p>Not Required</p>
<p>>></p>			
<p>Principle 8.2 Erosion and/or Water Body Instability</p>			
<p>Could the Project directly or indirectly cause additional erosion and/or water body instability or disrupt the natural pattern of erosion?</p>	<p>No</p>	<p>There is absence of sensitive ecological area (Reserve Forest area) in the core area of project. The removal of herbaceous vegetation from the soil and loosening of the topsoil generally causes soil erosion. However, such impacts would be primarily confined to the project site during initial periods of the construction phase and would be minimized through adoption of mitigation measures like paving and surface treatment and water sprinkling.</p>	<p>Not Required</p>
<p>>></p>			
<p>Principle 9.1 Landscape Modification and Soil</p>			

Does the Project involve the use of land and soil for production of crops or other products?	No	The project will be established at the desert/barren land which was not used for production of crops and other products for a long time.	Not Required
>>			
Principle 9.2 Vulnerability to Natural Disaster			
Will the Project be susceptible to or lead to increased vulnerability to wind, earthquakes, subsidence, landslides, erosion, flooding, drought or other extreme climatic conditions?	No	The project is susceptible to decreased vulnerability to wind, earthquakes, subsidence, landslides, erosion, flooding, drought or other extreme conditions.	Not Required
>>			
Principle 9.3 Genetic Resources			
Could the Project be negatively impacted by or involve genetically modified organisms or GMOs (e.g., contamination, collection and/or harvesting, commercial development, or take place in	No	The solar plant does not affect the herbal life.	Not Required

<p>facilities or farms that include GMOs in their processes and production)?</p>			
<p>>></p>			
<p>Principle 9.4 Release of pollutants</p>			
<p>Could the Project potentially result in the release of pollutants to the environment?</p>	<p>No</p>	<p>Being a Solar power project activity, it falls under the list of White category projects declared by Central Pollution Control Board of India, Govt of India. This means project activity does not potentially result in release of pollutants to the environment.</p>	<p>Not Required</p>
<p>>></p>		<p>Nevertheless, the project takes a precautionary approach regarding environmental challenges and is not complicit in practices contrary to the precautionary principle. The environment is protected by several Laws and Regulations in India. The purpose of the “Law on Environmental Protection” is to protect the environment with principles of sustainable development and</p>	

		environment ²⁰ . The project owner also follows necessary procedures for environmental safety at the project.	
Principle 9.5 Hazardous and Non-hazardous Waste			
Will the Project involve the manufacture, trade, release, and/ or use of hazardous and non-hazardous chemicals and/or materials?	No	All hazardous and non-hazardous wastes will be disposed as per the local regulations. Hazardous waste viz. waste oil used oil, used grease, wastes or residues containing oil, empty barrels/ containers/ liners wastes or residues Containing oil etc. will be collected and stored in paved and enclosed area with secondary containment and subsequently sold to authorized recyclers/ Transfer storage disposal facility (TSDF) in compliance with RSPCB norms. Hazardous Waste authorization as per Hazardous and Other Wastes (Management and Transboundary	Not Required
>>			

²⁰ file:///C:/Users/hp/Downloads/The-Environment-Protection-Act-1986.pdf

		Movement) Rules, 2016 should be obtained from RSPCB.	
Principle 9.6 Pesticides & Fertilisers			
Will the Project involve the application of pesticides and/or fertilisers?	No	Not applicable for solar power plants.	Not Required
>>			
Principle 9.7 Harvesting of Forests			
Will the Project involve the harvesting of forests?	No	No, the project does not involve harvesting of forest. The Solar Panels are all developed on government & private land and all of them will belongs to PP under the lease agreement for the project lifetime only. Moreover, the project is not located with close proximity of any forest.	Not Required
>>			
Principle 9.8 Food			
Does the Project modify the quantity or nutritional quality of food	No	No. The project does not modify the quantity or nutritional quality of food available.	Not Required

available such as through crop regime alteration or export or economic incentives?			
>>			
Principle 9.9 Animal husbandry			
Will the Project involve animal husbandry?	No	No. Not applicable for solar project.	Not required
>>			
Principle 9.10 High Conservation Value Areas and Critical Habitats			
Does the Project physically affect or alter largely intact or High Conservation Value (HCV) ecosystems, critical habitats, landscapes, key biodiversity areas or sites identified?	No	There is no source of surface water in the Project area or its vicinity. No reserve forest / protected forest or ecological sensitive area is located near the Project site. Further as per the consultation with villagers no wild species are observed in the area. Also, no forest land is involved in this project. There is no direct threat to wild species. Nevertheless, measures must be taken to avoid all forms of man animal conflict. Adequate safeguards	Not Required
>>			

		must be followed during construction and operation phase to prevent unwanted utilization of fertile land, forest land and forest resources.	
Principle 9.11 Endangered Species			
<p>Are there any endangered species identified as potentially being present within the Project boundary (including those that may route through the area)?</p> <p>AND/OR</p> <p>Does the Project potentially impact other areas where endangered species may be present through transboundary affects?</p>	No	No. There were no endangered species or ecologically significant animal and plant species found in the project boundary.	Not required

APPENDIX 2- CONTACT INFORMATION OF PROJECT PARTICIPANTS

Organization name	Fortum FinnSurya Energy Pvt. Ltd.
Registration number with relevant authority	U40300DL2013FTC259011
Street/P.O. Box	Unit No. 8-12,
Building	Ground Floor, World Trade Centre, Baber Road,
City	New Delhi
State/Region	New Delhi
Postcode	110001
Country	India
Telephone	+91-85276-94527
E-mail	atishay.jain@fortum.com
Website	fortum.india@fortum.com
Contact person	Mr. Atishay Jain
Title	Vice President
Salutation	Mr
Last name	Jain
Middle name	
First name	Atishay
Department	
Mobile	
Direct tel.	+91-124-4418827
Personal e-mail	atishay.jain@fortum.com

APPENDIX 3- LUF ADDITIONAL INFORMATION

NA

APPENDIX 4-SUMMARY OF APPROVED DESIGN CHANGES

NA

Revision History

Version	Date	Remarks
1.2	14 October 2020	Hyperlinked section summary to enable quick access to key sections Improved clarity on Key Project Information Inclusion criteria table added Gender sensitive requirements added Prior consideration (1 yr rule) and Ongoing Financial Need added Safeguard Principles Assessment as annex and a new section to include applicable safeguards for clarity Improved Clarity on SDG contribution/SDG Impact term used throughout Clarity on Stakeholder Consultation information required Provision of an accompanying Guide to help the user understand detailed rules and requirements
1.1	24 August 2017	Updated to include section A.8 on 'gender sensitive' requirements
1.0	10 July 2017	Initial adoption