



**Verified Carbon
Standard**

ALAÇATI WIND POWER PROJECT, TURKEY

Document Prepared by Sekans Danismanlik

Project Title	Alaçatı Wind Power Project, Turkey
Version	4
Report ID	ALACAT11
Date of Issue	10.08.2021
Project ID	1437
Monitoring Period	03-Jun-2016 to 28-February-2021
Prepared By	SEKANS DANIŞMANLIK
Contact	Konaklar Mah.34330, Yeni Levent-İstanbul E-mail: sila@sekansdanismanlik.com Phone: +90 532 438 30 29

CONTENTS

1	PROJECT DETAILS.....	3
1.1	Summary Description of the Implementation Status of the Project.....	3
1.2	Sectoral Scope and Project Type.....	5
1.3	Project Proponent	5
1.4	Other Entities Involved in the Project	5
1.5	Project Start Date	6
1.6	Project Crediting Period	6
1.7	Project Location.....	6
1.8	Title and Reference of Methodology	8
1.9	Participation under other GHG Programs	8
1.10	Other Forms of Credit.....	8
1.11	Sustainable Development	8
2	SAFEGUARDS	9
2.3	AFOLU-Specific Safeguards	11
3	IMPLEMENTATION STATUS	11
3.1	Implementation Status of the Project Activity	11
3.2	Deviations	12
3.3	Grouped Projects	12
4	DATA AND PARAMETERS.....	12
4.1	Data and Parameters Available at Validation.....	12
4.2	Data and Parameters Monitored.....	17
4.3	Monitoring Plan.....	19
5	QUANTIFICATION OF GHG EMISSION REDUCTIONS AND REMOVALS	21
5.1	Baseline Emissions	21
5.2	Project Emissions	24
5.3	Leakage.....	24
5.4	Net GHG Emission Reductions and Removals.....	24

1 PROJECT DETAILS

1.1 Summary Description of the Implementation Status of the Project

The Alaçatı Wind Power Project, Turkey (hereafter referred to as the “Project” or “Alaçatı WPP”), which is developed by Egenda Ege Enerji Üretim A.Ş. (hereafter referred to as the “project owner”) is a wind power plant in İzmir Province of Turkey.

The Project has been implemented and operated by Egenda Ege Enerji Üretim A.Ş. The project aims to generate electricity from wind energy and feed it to the national electricity grid.

Total installed power generation capacity of the project is 16 MW, consisting of 8 wind turbines, with an estimated power supply to the grid of 49,822 MWh of net electricity generation per annum. The project is connected to 380 kV Çeşme Havza TM’s OG and then Çeşme is connected to the 380 kV Çeşme Havza TM. The estimated amount of GHG emission reduction is 29,062 tonnes CO₂e per year in the registered PDD. During its operation during this monitoring period, the actualized net electricity generation is 227,658.31 MWh. The actual emission reduction has been calculated as 132,790 tonnes CO₂ for this monitoring period.

The project has produced positive environmental benefits as displacing the electricity generated by fossil fuel fired power plants by utilising the renewable resources so as to avoid environmental pollution and GHG emissions.

The project includes 8 units of Enercon E82 E2 type turbines, each having a capacity of 2 MW.¹

The start date of the project activity is 03/06/2016.

Please see the vintage-based comparison of expected and achieved emission reductions for this monitoring period:

Table 1 - Expected vs achieved emission reductions

¹ Ministry Acceptance Protocols are available to the DOE.

Vintage	Period	Total Days	Amount achieved during this monitoring period (tCO ₂ e)	Amount estimated ex ante (tCO ₂ e)	Difference (tCO ₂ e)	Difference (%)
2016	03.06.2016 - 31.12.2016	212	17,231	16,880	351	2.1%
2017	01.01.2017 - 31.12.2017	365	27,366	29,062	-1,696	-5.8%
2018	01.01.2018 - 31.12.2018	365	26,038	29,062	-3,024	-10.4%
2019	01.01.2019 - 31.12.2019	365	27,725	29,062	-1,337	-4.6%
2020	01.01.2020 - 31.12.2020	365	27,950	29,062	-1,112	-3.8%
2021	01.01.2021 - 28.02.2021	59	6,480	4,698	1,782	37.9%
Total		1731	132,790	137,826	-5,036	-3.7%

Table 2 - Monitoring timeline of the Project Activity

Date (Period)	Activity
18/05/2009	Issuance of "EIA not Required Certificate"
27/08/2018	Land Permit
27/10/2015	Construction Start Date (Construction Agreement)
03/06/2016	Commisioning of the Project
03/06/2016 – 28/02/2021	1 st Monitoring Report

Table 3 - Key technical specifications of wind turbines

Parameter	Value
Rated Power	2000 kW
Rotor Diameter	82 m
Number of Blades	3
Swept Area	5281 m ²
Hub Height	78 m

Rotor Speed	18.0 U/min
Generator	Synchronous, direct-drive ringgenerator
Cut out wind speed	28/34 m/s

1.2 Sectoral Scope and Project Type

According to UNFCCC sectoral scopes definition for CDM projects, the Project Activity is included in the Sectoral Scope 1, category “Energy industries (renewable - / nonrenewable sources)”. The project is a single green field investment and is not part of a project group or bundle.

1.3 Project Proponent

Organization name	Egenda Ege Enerji Üretim A.Ş.
Contact person	Mr. Fatih Çandır
Title	Energy Trade and Corporate Relations Department
Address	–Şehir Nevres Bulvarı, No:10, Kat:7, Deren Plaza, Montrö / İzmir
Telephone	+90 232 463 98 11
Email	fatih.candir@endaeneerji.com.tr

1.4 Other Entities Involved in the Project

Organization name	Sekans Danışmanlık
Role in the Project	Consultant
Contact person	Sıla Duran
Title	Consultant

Address	Konaklar Mah. 34330,4. Levent - Istanbul
Telephone	-
Email	sil@sekansdanismanlik.com

1.5 Project Start Date

The project start date is 03/06/2016 which is the commissioning date of the project.²

1.6 Project Crediting Period

The Project's total crediting period is ten years renewable twice: 03/06/2016 – 02/06/2026 (both days are included).

1.7 Project Location

The wind power plant is located about 5.8 km southeast of Çeşme town of İzmir in Turkey.

Aegean Sea is located 2.4 km north of the project, Ovacık and Alaçatı are located respectively 2.8 km and 2 km east of the project, 1.1 km south of the project is Çeşme-İzmir road.

The closest settlement to the project site is Ilıca which is about 1.6 km away to the north of the wind farm and Reisdere Neighbourhood which is about 1.3 km away to the north of the plant.

² Ministry Acceptance Protocols are available to the DOE.



Figure 1. Location of Alaçatı Wind Power Project

Table 4 – Geographical coordinates of the wind turbines of the project activity³

Wind Turbine No	Latitude (N)	Longitude (E)
1	442997	4238651
2	442866	4238287
3	442803	4237919
4	443005	4237510
5	442756	4237510
6	442880	4237153

³ Generation license is available to the DOE.

7	442800	4236763
8	443029	4238000

1.8 Title and Reference of Methodology

For the determination of the baseline, the official methodology ACM0002 version 16.0.0, “Largescale Consolidated baseline methodology for grid-connected electricity generation from renewable sources”, is applied, using conservative options and data as presented in the following section. This methodology refers to five Tools, which are:

1. Tool to calculate the emission factor for an electricity system (Version 04.0.0)
2. Tool for the demonstration and assessment of additionality (Version 07.0.0)
3. Combined tool to identify the baseline scenario and demonstrate additionality (Version 05.0.0)
4. Tool to calculate project or leakage CO₂ emissions from fossil fuel combustion (Version 02.0.0)
5. Tool to determine the remaining lifetime of the equipment

For baseline calculation the first tool, for additionality assessment the second tool is used. As third tool is the combination of the first and second tool, it is not used. Since no project emission or leakage calculation is required for wind power project fourth tool is not used, and finally to determine the remaining lifetime of the equipment fifth tool is used.

1.9 Participation under other GHG Programs

The project has never been included in an emissions trading program or any other binding limits. It has neither received any kind of environmental credits nor been registered under any other GHG programs.

1.10 Other Forms of Credit

The project has not created another form of credit.

1.11 Sustainable Development

The project produces electricity from renewable energy sources using wind as the power source and to contribute to Turkey's growing electricity demand through a sustainable and low carbon technology. The project displaces the same amount of electricity generated by the grid dominated with fossil fired power plants. The project generates 49,822 MWh annually. The project contributes to the Sustainable Development Goal, Affordable and Clean Energy. During this monitoring period, the project has generated 227,658.31 MWh as contributing to SGD 7 Affordable and Clean Energy.

The annual emission reduction estimated by the project is 29,062 tonnes CO₂eq, approximately. While this amount of emissions is mitigated, technology transfer is also realized as benefitting from windpower. During this monitoring period, the project has contributed to SDG 13 Climate Action as reducing 132,790 tonnes CO₂.

The project contributes to improve the environmental situation in the region and in the country as avoiding fossil fuel-based electricity enhanced the air quality and help to reduce the negative effects on the climate. Through renewable technologies and wind-based electricity sustainable and climate friendly development is promoted. The project contributes to the Sustainable Development Goal, Climate Action.

During construction and operational period, the project has created employment opportunities for the local community. As contributing to SGD 8 Decent Work and Economic Growth, one Plant Manager and one chief technician are responsible for all five projects of the project owner. Besides this, eight control operators are working in shifts for the Project Activity.

The project contributes the economic development of the region by providing sustainable energy resources. The project provides workers with a safe and healthy work environment and is not complicit in exposing workers to unsafe or unhealthy work environments. Thus, the project contributes to the Sustainable Development Goal, Decent Work and Economic Growth.

2 SAFEGUARDS

2.1 No Net Harm

Within the scope of the project, all precautions have been taken for the environment during the design phase and the project will be implemented in line with the environmental law and related regulations.

The purpose of the project activity is to generate power in an efficient, clean, reliable and sustainable way with maximum respect on social and environmental aspects and to reduce emissions by partially substituting the electricity supply of fossil fuel fired power plants in

Turkey. The consequences of the Project Activity with regards to economic, social and environmental impacts have been assessed during EIA process.

There is no agricultural area in the project area and the lands were owned by the state. The land permit was taken from the General Directorate of Forestry on 18/02/2015 and 09/08/2018.

Regarding the wastes, hazardous wastes are handled appropriately in closed containers and transported by licensed transporters to the licensed processing and disposal facilities⁴.

Wastewater is collected through within the septic tank and is transferred through the sewage truck⁵.

The domestic wastes are taken to the containers of the Municipality by the site personnel. The signed declaration of the PP is available to the DOE.

There is not any negative environmental or socio-economic impact.

2.2 Local Stakeholder Consultation

According to the regulation declared by the Ministry of Environment and Forestry and published on the Official Gazete (dated 17th July 2008, numbered 26939), projects which have EIA is not required certificate are not obligated to hold Stakeholder Meetings. Nevertheless, a stakeholder meeting held on 08/11/2012 in Alaçatı Municipality meeting hall which is the closest settlement area to the project area. However, as it is explained above no one participated in the meeting. To reach the local stakeholders and hear their opinions, project proponent went to their shops and talked with them in the street.

Locals of the Alaçatı are not stranger to the wind power plants. In that region there are many wind power plants, that's way most of the locals did not pay attention to the local stakeholder meeting of the Alaçatı WPP. Also, locals supported to wind power plants as it can be understood from the evaluation forms.

Local people were employed during construction and are being employed during operation. This contributes to local economy and leads to improvement in living standards.

The Project has resulted in the creation of new jobs in the project region and improvement in local roads, contributing to living standards in the region. Moreover, the project owner has provided contribution in kind to the local community, although these activities are not required legally. As a result, the community is supporting the project and they believe that it

⁴ Hazardous waste transfer records are available to the DOE.

⁵ The wastewater transfer receipts are available to the DOE.

creates a momentum for local sustainable development. Any complaint or need from the local community could directly be received by the project owner and appropriate contributions or improvements are made to the local community. An announcement (dated on 02/03/2021) stating the contact details of the Project relevant staff in case of any complaint by close surroundings has been put up on the Mosque of the Alaçatı town to be seen by the villagers. Regarding the monitoring period, no complaint has been received from the villagers.

There was no specific environmental problem that concerned the locals more than others, and environmental issues need to be solved by the government. All people considered clear signs of climate change in the region in recent years.

The contact information of the plant responsible exist at the Mukhtar, the project owner and local community are always in touch. The project owner regularly checks with the Mukhtar if any complaint or a request exists. Any complaint or need from the local community could directly be received by the project owner and appropriate contributions or improvements are made to the local community.

There is no update on project design.

2.3 AFOLU-Specific Safeguards

N/A

3 IMPLEMENTATION STATUS

3.1 Implementation Status of the Project Activity

The description of the implementation and operational status of the project and the installed technology(ies), technical process and equipment are detailed in Section 1.1.

The Egenda Ege Enerji Üretim A.Ş. is the owner of the Project. Shareholder structure has been changed a few times. The latest structure change was on 20/05/2019 as the main shareholder Enda Enerji Holding A.S.

Other entity involved in the project was Lifenerji Ltd. Şti. in the project description. However, it's been changed as Sekans Danışmanlık during the 1st Monitoring Period.

3.2 Deviations

3.2.1 Methodology Deviations

There are no methodology deviations applied during this monitoring period.

3.2.2 Project Description Deviations

The first 10-year crediting period was planned as from 1st of June 2016 to 31st of May 2026 as in registered PD. But the project started its operation in 03/06/2016, since the project processes took more time than it was expected. Thus, the project start date is 03/06/2016. And the Project's crediting period is: 03/06/2016 – 02/06/2026, currently.

The Egenda Ege Enerji Üretim A.Ş. is the owner of the Project. Shareholder structure has been changed a few times. The latest structure change was on 20/05/2019 as the main shareholder Enda Enerji Holding A.S.

Other entity involved in the project was Lifenerji Ltd. Şti. in the project description. However, it has been changed as Sekans Danışmanlık during the 1st Monitoring Period.

3.3 Grouped Projects

This is not a grouped project.

4 DATA AND PARAMETERS

4.1 Data and Parameters Available at Validation

Data / Parameter	Gross electricity generation
Data unit	MWh
Description	Gross Electricity supplied to the grid by relevant sources (2009-2011)
Source of data	Turkish Electricity Transmission Company (TEİAŞ), Annual Development of Turkey's Gross Electricity Generation of Primary Energy Resources (1975-2011) TEİAŞ https://www.teias.gov.tr/tr-TR/turkiye-elektrik-uretim-iletimistatistikleri
Value applied	Please refer to Table 13 in the PDD

Justification of choice of data or description of measurement methods and procedures applied	TEIAS annually publishes official data regarding electricity generation. Average share of each source in the overall generation has been calculated.
Purpose of Data	Data used for emission reduction calculation
Comments	-

Data / Parameter	EF_{grid, CM, y}
Data unit	tCO ₂ /MWh
Description	Combined margin CO ₂ emission factor for the project electricity system in year 2011
Source of data	As per “Tool to calculate the emission factor for an electricity system”
Value applied	0.5833 tCO ₂ /MWh
Justification of choice of data or description of measurement methods and procedures applied	As per “Tool to calculate the emission factor for an electricity system” Calculated from data provided by the TEIAS for Turkish Power Sector; Operating Margin = 0.6542 KgCO ₂ e/kWh Build Margin = 0.3707 KgCO ₂ e/kWh Combined Margin = 0.5833 KgCO ₂ /kWh
Purpose of Data	Used for baseline emissions
Comments	-

Data / Parameter	Eg_y
Data unit	MWh
Description	Net electricity generated by project electricity system in year 2009, 2010 and 2011
Source of data	Turkish Electricity Transmission Company (TEIAS), Annual Development of Electricity Generation- Consumption and Losses in Turkey (1984-2011) TEIAS

	https://www.teias.gov.tr/tr-TR/turkiye-elektrik-uretim-iletimistatistikleri
Value applied	Please refer to Table 14 and Table 15 in the PDD
Justification of choice of data or description of measurement methods and procedures applied	TEIAS annually publishes official data regarding total net electricity generation, but its breakdown by fuel type is unavailable.
Purpose of Data	Data used for emission reduction calculation
Comments	-

Data / Parameter	EF_{CO2,i,y}
Data unit	tCO ₂ /GJ
Description	CO ₂ emission factor of fuel type i used in power unit m in year 2011
Source of data	PCC default values at the lower limit of the uncertainty at a 95% confidence interval as provided in table 1.4 of Chapter1 of Vol. 2 (Energy) of the IPCC Guidelines on National GHG Inventories. http://www.ipccnggip.iges.or.jp/public/2006gl/pdf/2_Volume2/V2_1_Ch1_Introduction.pdf
Value applied	Please refer to Table 18 and Table 21 in the PDD
Justification of choice of data or description of measurement methods and procedures applied	No plant specific and national emission factor data is available in Turkey. So, IPCC default data is used. For Fuel Oil Power Plants: 'Gas/Diesel Oil' data is used for conservativeness. For Coal Power Plants: In the 205 th page of official document given in the link below, it is stated that Çolakoğlu and İçdaş utilizes 'Taşkömürü' (Hardcoal). And at the Table-2 in page 157 of the same document, Taşkömürü is divided in two groups: Bituminous and Anthracite. Since Sub-Bituminous Coal is under Brown Coal in the same table and since Other Bituminous Coal has lower EF than Anthracite in 1.4 of IPCC Guidelines, EF for 'Other Bituminous Coal' is used. See: http://www.dpt.gov.tr/DocObjects/Icerik/4225/Enerji_Hammadeleri_(Linyit_Taşkömuru-Jeotermal)
Purpose of Data	Data used for emission reduction calculation
Comments	-

Data / Parameter	Sample Group for BM emission factor
Data unit	Name of the plants, MW capacities, fuel types, annual electricity generations and dates of commissioning.
Description	Most recent power plants which compromise 20% of total generation
Source of data	Annual Development Of Fuels Consumed In Thermal Power Plants In Turkey By The Electric Utilities, TEIAS: http://www.epdk.org.tr/yayin_rapor/elektrik/yayin/uretimKapasiteProjeksiyonu.pdf http://www.epdk.org.tr/yayin_rapor/elektrik/yayin/uretimKapasiteProjeksiyonu2008_2017.pdf http://www.teias.gov.tr/projeksiyon/KAPASITEPROJEKSİYONU2009.pdf http://www.teias.gov.tr/projeksiyon/KAPASITE%20PROJEKSİYONU%202010.pdf http://www.epdk.org.tr/documents/10157/8edb1470-7667-4ce1-8ce5-21d1ce4e4761 http://www.teias.gov.tr/KAPASITEPROJEKSİYONU2012.pdf
Value applied	Please refer to table 23 in the PDD
Justification of choice of data or description of measurement methods and procedures applied	The Turkish Electricity Distribution Company. TEIAS is the national electricity transmission company, which makes available the official data of all power plants in Turkey. The latest data available during PDD preparation was for 2011.
Purpose of Data	Data used for emission reduction calculation
Comments	-

Data / Parameter	$\eta_{i,y}$
Data unit	-
Description	Average energy conversion efficiency of power unit m in year y
Source of data	Annex I the “Tool to calculate the emission factor for an electricity system”
Value applied	Please refer to table 18 in the PDD

Justification of choice of data or description of measurement methods and procedures applied	For efficiency rates of Coal and Lignite Power Plants See Annex-1 of the Tool (highest rate is applied to be conservative) For Natural Gas and Oil plants efficiencies, default value given in the tool is applied: http://cdm.unfccc.int/methodologies/PAMethodologies/tools/am-tool-07-v2.pdf
Purpose of Data	Data used for emission reduction calculation
Comments	-

Data / Parameter	HV_{i,y}
Data unit	Mass or volume unit
Description	Heating Values of fuels consumed for electricity generation in the years of 2009, 2010 and 2011
Source of data	TEİAŞ (Turkish Electricity Transmission Company) http://www.teias.gov.tr/istatistikler.aspx
Value applied	Please refer to Table 19 in the PDD
Justification of choice of data or description of measurement methods and procedures applied	TEİAŞ is the national electricity transmission company, which makes available the official data of all power plants in Turkey. There is no national NVC data in Turkey. However, TEİAŞ announces Heating values of fuels. This data is used to calculate annual NCVs for each fuel type.
Purpose of Data	Data used for emission reduction calculation
Comments	-

Data / Parameter	FC_{i,y}
Data unit	Mass or volume unit
Description	Amount of fuel type i consumed by relevant power plants in Turkey in the years of 2009, 2010 and 2011
Source of data	TEİAŞ (Turkish Electricity Transmission Company) http://www.teias.gov.tr/istatistikler.aspx
Value applied	Please refer to Table 20 in the PDD
Justification of choice of data or description of measurement methods and procedures applied	TEİAŞ is the national electricity transmission company, which makes available the official data of all power plants in Turkey.
Purpose of Data	Data used for emission reduction calculation

Comments	-
Data / Parameter	NCV_{i,y}
Data unit	TJ/kton, TJ/million m3
Description	Net calorific value (energy content) of fuel type i in years of 2009, 2010 and 2011
Source of data	Calculated by using HVi,y to FCi,y as Net Calorific Values of fuel types are not directly available in Turkey.
Value applied	Please refer to section Table 21 in the PDD
Justification of choice of data or description of measurement methods and procedures applied	According to “Turkish Statistics Law and Official Statistics Program” TEIAS, the Turkish Electricity Transmission Company is the official source for the related data, hence providing the most up-to-date and accurate information available. Calculation of NCVs from national HVi,y and FCi,y data is preferred to default IPCC data as these are more reliable.
Purpose of Data	Used to calculate the combined margin emission factor
Comments	-

4.2 Data and Parameters Monitored

Data / Parameter	EG_{facility,y}
Data unit	MWh/yr
Description	Quantity of net electricity generation supplied to the grid in year y
Source of data	The data from the Electricity Meters are the basis for the settlement notification of EPIAS ⁶ . Data are gathered electronically from the meters by TEIAS and stored in secured website of EPIAS, which is accessible to project developer with a private password. For monitoring, the monthly settlement notification of EPIAS shall be used as source of data.

⁶ PMUM has been replaced by EPIAS as of 01/09/2015 in Turkey. Retrospective data is accessible via EPIAS

Description of measurement methods and procedures to be applied	Alaçatı WPP is connected to 380 kV Çeşme Havza TM's OG and then Çeşme is connected to the 380 kV Çeşme Havza TM. There are two metering instruments (power meters). These devices measure the net electricity supply to the national grid by the Project Activity, all losses before this point are on account of the project participant. Both metering instruments, which continuously monitor and measure the net electricity delivered by the Project Activity, are sealed and only accessible by TEIAS personnel. Official TEIAS data from the EPIAS web site was used for calculating EG _y .																		
Frequency of monitoring/recording	Continuously monitoring and monthly readings																		
Value monitored	29,540.86 MWh for 2016 46,916.94 MWh for 2017 44,639.81 MWh for 2018 47,531.51 MWh for 2019 47,918.45 MWh for 2020 11,110.75 MWh for 2021																		
Monitoring equipment	<p>Both exported and imported electricity are measured continuously by a power meter at the grid interface and recorded monthly.</p> <p>Power meters:</p> <table border="1" data-bbox="634 1115 1417 1455"> <thead> <tr> <th></th> <th>Main Meter</th> <th>Spare Meter</th> </tr> </thead> <tbody> <tr> <td>Name</td> <td>Ana Sayaç</td> <td>Yedek Sayaç</td> </tr> <tr> <td>Brand</td> <td>EMH (LZQJ-XC)</td> <td>EMH (LZQJ-XC)</td> </tr> <tr> <td>Serial Number</td> <td>4213173</td> <td>4213174</td> </tr> <tr> <td>Latest Test Date of the Meters</td> <td>19/09/2020</td> <td>19/09/2020</td> </tr> <tr> <td>Accuracy Class</td> <td>0.2S class</td> <td>0.2S class</td> </tr> </tbody> </table> <p>The dates of the meter tests are 04/06/2016, 21/12/2016, 08/12/2017, 14/08/2018 and 19/09/2020.</p>		Main Meter	Spare Meter	Name	Ana Sayaç	Yedek Sayaç	Brand	EMH (LZQJ-XC)	EMH (LZQJ-XC)	Serial Number	4213173	4213174	Latest Test Date of the Meters	19/09/2020	19/09/2020	Accuracy Class	0.2S class	0.2S class
	Main Meter	Spare Meter																	
Name	Ana Sayaç	Yedek Sayaç																	
Brand	EMH (LZQJ-XC)	EMH (LZQJ-XC)																	
Serial Number	4213173	4213174																	
Latest Test Date of the Meters	19/09/2020	19/09/2020																	
Accuracy Class	0.2S class	0.2S class																	
QA/QC procedures to be applied	<ul style="list-style-type: none"> • A spare meter is used for crosschecking the accuracy and both meters are calibrated if required. • EPIAS records are considered as the main source for the net electricity and the values are crosschecked with the Meter Reading Forms • TEIAS is responsible for calibration and maintenance of the devices. The periodic calibration or maintenance 																		

	is under the responsibility of TEİAŞ and has been fixed as once in 10 years ⁷ . Since TEİAŞ meters are sealed by TEİAŞ, the project proponent cannot intervene with the devices. The periodic tests are executed on annual basis.
Purpose of the data	Calculation of net electricity supplied to the grid and thus baseline emissions
Calculation method	Direct continuous measurement
Comments	-

4.3 Monitoring Plan

The objective of the monitoring plan is to ensure the complete, consistent, clear, and accurate monitoring and calculation of the emission reductions during the whole crediting period. The Project proponent is responsible for the implementation of the monitoring plan.

The Project Proponent is responsible for the overall management of the monitoring procedures including recording, data collection, calculating emission reductions and project emissions.

Please see below the management structure for the plant operation:

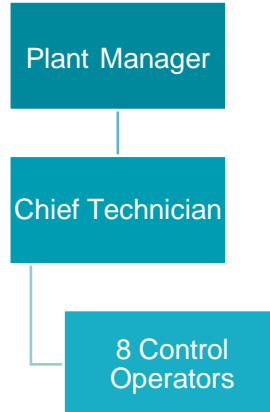

Figure 2. The management structure for the plant operation

⁷ 4 <http://www.mevzuat.gov.tr/Metin.Aspx?MevzuatKod=7.5.6381&MevzuatIliski=0&sourceXmlSearch>

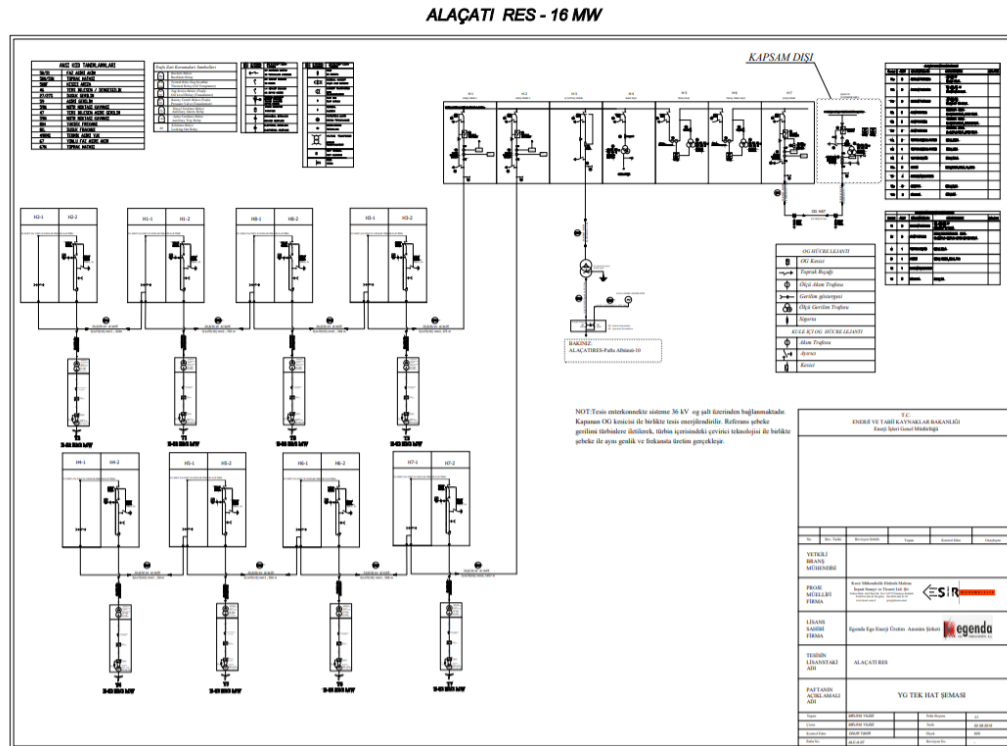

Figure 3. The Single Line Diagram of Alaçati WPP

One Plant Manager and one chief technician are responsible for all five projects of the project owner. Besides this, eight control operators are working in shifts for the Project Activity. Project Manager is responsible for all issues related to project and operation of the plant. Chief Technician is responsible for daily operational processes of the plant, management of the plant personnel, and other technical and management issues for the plant. Control Operators are responsible for monitoring of the plant and turbines for all day and night in the control room. In total, 10 employees are working for the project.

Two power meters are installed at the grid interface of the project. One is the main meter and the other is spare meter of the main meter for cross-checking. Both meters are jointly inspected and sealed in order to be protected from interference by any of the parties. Both the main and secondary meters are owned and installed by the grid operator (TEIAS). The grid operator's is the only one authorized to deal with fixing, calibrating, or changing the meters, which were done either by the grid operator or by a company authorized by the grid operator. During this monitoring period, there were no records of meter failure. In case of any urgent case TEIAS contacts the Plant Manager. Since the meters are within TEIAS' province, TEIAS executes all the procedures for handling non-conformities. Therefore, the Project Participant does not have any internal auditing for this purpose.

TEIAS is performing remote reading of the meters and monthly power meter readings are the basis for monitoring net electricity fed into the grid. A measuring protocol is prepared including day, peak and night hour electricity generation by the project owner and approved by governmental officers at the end of each month.

The primary source is the EPIAS records. Net electricity exported is crosschecked with Meter Reading Forms. EPIAS is the financial settlement center of TEIAS⁸. The Meter Reading Forms are filled by the project owner and approved by the governmental officers. Additionally, the remote reading by the governmental body is also available. The website of EPIAS is accessible to Project Proponent with their unique user ID and password. Once accessed, the Project Proponent is able to call electricity generation and consumption reports of their own projects. The same reports are used by the Project Proponent for invoicing TEIAS. The electricity generation data is reported monthly basis.

5 QUANTIFICATION OF GHG EMISSION REDUCTIONS AND REMOVALS

5.1 Baseline Emissions

The baseline emission BE_y (tCO₂e) during the monitoring period results from:

$$BE_y = EG_{PJ, y} * EF_{grid, CM, y}$$

Where:

BE _y	Baseline emissions in year y (tCO ₂ e/y)
EG _{PJ,y}	Quantity of net electricity supplied to the grid as a result of the implementation of the CDM project activity in year y (MWh)
EF _{grid,CM,y}	Combined margin CO ₂ emission factor for grid connected power generation in year y calculated by using the latest version of the “Tool to calculate the emission factor for an electricity system” (tCO ₂ /MWh)

⁸ PMUM has been replaced by EPIAS as of 01/09/2015 in Turkey during the verification period. Retrospective data is accessible via EPIAS.

Table 5 - Baseline emissions

Month	(A) Electricity supplied to the grid [MWh]	(B) Electricity consumption from the grid [MWh]	(C) = (A) - (B) EG (ID 8) Net electricity supplied to the grid [MWh]	EF [tCO ₂ /MWh]	Baseline emission: ER = EG * EF [t CO ₂ -eq]
Jun-16	2,859.85	1.42	2,858.43	0.5833	1,667
Jul-16	6,149.30	0.65	6,148.65	0.5833	3,587
Aug-16	3,865.33	1.66	3,863.67	0.5833	2,254
Sep-16	3,742.08	3.30	3,738.78	0.5833	2,181
Oct-16	3,252.79	1.84	3,250.96	0.5833	1,896
Nov-16	4,393.90	1.06	4,392.84	0.5833	2,562
Dec-16	5,288.66	1.12	5,287.54	0.5833	3,084
Jan-17	4,535.17	1.03	4,534.14	0.5833	2,645
Feb-17	5,112.36	0.65	5,111.71	0.5833	2,982
Mar-17	3,100.14	1.21	3,098.93	0.5833	1,808
Apr-17	2,517.81	2.01	2,515.80	0.5833	1,467
May-17	3,113.94	2.08	3,111.86	0.5833	1,815
Jun-17	2,271.82	4.05	2,267.77	0.5833	1,323
Jul-17	5,119.08	1.21	5,117.87	0.5833	2,985
Aug-17	5,431.71	1.26	5,430.45	0.5833	3,168
Sep-17	2,656.06	2.96	2,653.10	0.5833	1,548
Oct-17	4,223.80	1.52	4,222.28	0.5833	2,463
Nov-17	2,743.50	2.59	2,740.91	0.5833	1,599
Dec-17	6,112.74	0.64	6,112.10	0.5833	3,565
Jan-18	4,732.26	2.03	4,730.23	0.5833	2,759
Feb-18	3,864.42	1.13	3,863.30	0.5833	2,253
Mar-18	6,517.42	0.83	6,516.59	0.5833	3,801
Apr-18	2,125.47	2.40	2,123.07	0.5833	1,238
May-18	2,706.30	2.59	2,703.71	0.5833	1,577
Jun-18	2,295.16	2.55	2,292.61	0.5833	1,337
Jul-18	3,794.39	1.01	3,793.39	0.5833	2,213
Aug-18	3,561.36	1.87	3,559.49	0.5833	2,076
Sep-18	3,711.23	1.35	3,709.88	0.5833	2,164
Oct-18	2,592.54	1.14	2,591.41	0.5833	1,512
Nov-18	4,654.50	1.02	4,653.47	0.5833	2,714
Dec-18	4,104.63	1.96	4,102.67	0.5833	2,393
Jan-19	5,563.38	1.14	5,562.24	0.5833	3,244
Feb-19	4,701.15	0.98	4,700.17	0.5833	2,742

Mar-19	4,813.00	1.00	4,812.00	0.5833	2,807
Apr-19	3,833.38	1.03	3,832.36	0.5833	2,235
May-19	2,554.79	1.87	2,552.93	0.5833	1,489
Jun-19	4,055.42	0.64	4,054.78	0.5833	2,365
Jul-19	4,007.36	1.19	4,006.16	0.5833	2,337
Aug-19	4,894.81	0.57	4,894.24	0.5833	2,855
Sep-19	3,691.88	1.86	3,690.02	0.5833	2,152
Oct-19	2,233.59	3.74	2,229.85	0.5833	1,301
Nov-19	3,236.34	2.08	3,234.26	0.5833	1,887
Dec-19	3,964.58	2.08	3,962.51	0.5833	2,311
Jan-20	5,756.81	0.99	5,755.82	0.5833	3,357
Feb-20	4,986.59	1.04	4,985.55	0.5833	2,908
Mar-20	4,586.63	1.34	4,585.28	0.5833	2,675
Apr-20	3,478.92	1.55	3,477.37	0.5833	2,028
May-20	3,201.04	2.85	3,198.19	0.5833	1,866
Jun-20	2,387.79	1.85	2,385.94	0.5833	1,392
Jul-20	4,526.99	0.51	4,526.49	0.5833	2,640
Aug-20	4,501.60	0.83	4,500.77	0.5833	2,625
Sep-20	3,144.84	2.43	3,142.41	0.5833	1,833
Oct-20	2,010.10	2.70	2,007.40	0.5833	1,171
Nov-20	4,576.12	0.71	4,575.41	0.5833	2,669
Dec-20	4,778.93	1.10	4,777.83	0.5833	2,787
Jan-21	6,316.06	0.56	6,315.50	0.5833	3,684
Feb-21	4,796.72	1.48	4,795.24	0.5833	2,797
2016 Vintage (03.06.2016- 31.12.2016)	29,551.91	11.05	29,540.86	0.5833	17,231
2017 Vintage (01.01.2017- 31.12.2017)	46,938.13	21.20	46,916.94	0.5833	27,366
2018 Vintage (01.01.2018- 31.12.2018)	44,659.69	19.88	44,639.81	0.5833	26,038
2019 Vintage (01.01.2019- 31.12.2019)	47,549.68	18.17	47,531.51	0.5833	27,725
2020 Vintage (01.01.2020- 31.12.2020)	47,936.36	17.91	47,918.45	0.5833	27,950
2021 Vintage (01.01.2021- 28.02.2021)	11,112.78	2.03	11,110.75	0.5833	6,480
Total	227,748.55	90.23	227,658.31	0.5833	132,790

5.2 Project Emissions

In accordance with the methodology, no project emissions need to be considered. Project emissions apply only for geothermal power plants, solar thermal power plants and for some hydro power plants.

Therefore, PEy =0.

5.3 Leakage

No leakage is to be accounted by the Project Activity. This is in line with the registered PD and applicable methodology ACM0002 version 16.0.0. Therefore, the leakage from the Project Activity is zero.

5.4 Net GHG Emission Reductions and Removals

Year	Baseline emissions or removals (tCO ₂ e)	Project emissions or removals (tCO ₂ e)	Leakage emissions (tCO ₂ e)	Net GHG emission reductions or removals (tCO ₂ e)
2016	17,231	0	0	17,231
2017	27,366	0	0	27,366
2018	26,038	0	0	26,038
2019	27,725	0	0	27,725
2020	27,950	0	0	27,950
2021	6,480	0	0	6,480
Total	132,790	0	0	132,790