



**Verified Carbon
Standard**

AMBATOLAMPY 20 MW SOLAR PV

Document Prepared by AERA Group
On behalf of GreenYellow Madagascar



Project Title	Ambatolampy 20 MW solar PV
Version	1.1
Date of Issue	24-06-2020
Prepared By	AERA Group
Contact	28 Cours Albert 1er, 75008 Paris, France Ph +33 1 42 18 02 02 Fax +33 1 43 25 80 06 contact@aera-group.fr , www.aera-group.fr

CONTENTS

- 1.1 Summary Description of the Project 3
- 1.2 Sectoral Scope and Project Type 3
- 1.3 Project Eligibility 3
- 1.4 Project Design 3
- 1.5 Project Proponent 4
- 1.6 Other Entities Involved in the Project 4
- 1.7 Ownership..... 4
- 1.8 Project Start Date 4
- 1.9 Project Crediting Period 4
- 1.10 Project Scale and Estimated GHG Emission Reductions or Removals 4
- 1.11 Description of the Project Activity 5
- 1.12 Project Location 7
- 1.13 Conditions Prior to Project Initiation 8
- 1.14 Compliance with Laws, Statutes and Other Regulatory Frameworks 9
- 1.15 Participation under Other GHG Programs 9
- 1.16 Other Forms of Credit..... 9
- 1.17 Additional Information Relevant to the Project 9
- 2.1 No Net Harm 11
- 2.2 Local Stakeholder Consultation 11
- 2.3 Environmental Impact 11
- 2.4 Public Comments 11
- 2.5 AFOLU-Specific Safeguards 11
- 3.1 Title and Reference of Methodology 11
- 3.2 Applicability of Methodology 11
- 3.3 Project Boundary 11
- 3.4 Baseline Scenario 12
- 3.5 Additionality 12
- 3.6 Methodology Deviations 12
- 4.1 Baseline Emissions 12
- 4.2 Project Emissions 12
- 4.3 Leakage..... 12
- 4.4 Estimated Net GHG Emission Reductions and Removals..... 12
- 5.1 Data and Parameters Available at Validation 14
- 5.2 Data and Parameters Monitored..... 14
- 5.3 Monitoring Plan..... 14
- 6.1 Data and Parameters Monitored..... 14
- 6.2 Baseline Emissions 15
- 6.3 Project Emissions 16
- 6.4 Leakage..... 16
- 6.5 Net GHG Emission Reductions and Removals..... 16

1 PROJECT DETAILS

1.1 Summary Description of the Project

Ambatolampy 20 MW solar PV (“the project”) consists of the construction and operation of a greenfield 20 MW solar photovoltaic power plant by GreenYellow Madagascar (“GreenYellow”) in Ambatolampy, in the South-East of Vakinankaratra region, Madagascar. It involves the setting up of photovoltaic (PV) panels which will capture solar energy and convey such energy to the convertor station in order to produce electricity exported to the national grid.

Electricity in Madagascar is currently heavily reliant on imported fossil fuels currently consumed by thermal power stations (514 MW) versus hydropower plants (162 MW)¹, thus a baseline scenario also considered as the scenario prior to the implementation of the project activity leading to considerable greenhouse gas (GHG) emissions. The project activity undertaken by project promoter GreenYellow will therefore substitute grid electricity by clean and renewable energy, and cut down GHG emissions.

The project is the first large-scale solar PV power plant on the island and will generate approximately 23,431 tCO₂e emission reductions per year and 164,018 tCO₂e of emission reductions over the 7 years crediting period.

1.2 Sectoral Scope and Project Type

The sectoral scope is Scope 1 – Energy Industries (renewable sources) – ACM0002: Large-scale Consolidated Methodology: Grid-connected electricity generation from renewable sources, Version 19.0.

The project is a renewable energy type and is not a grouped project.

1.3 Project Eligibility

The project is eligible under the scope of the VCS Program because:

- It results in CO₂ emission reductions, one of the six Kyoto Protocol greenhouse gases
- It consists in grid-connected electricity generation using (large scale) solar power plant in a Least Developed Country

1.4 Project Design

The project has been designed to include a single installation of an activity.

Eligibility Criteria

N/A

¹ <https://www.africa-eu-renewables.org/market-information/madagascar/energy-sector/>

1.5 Project Proponent

Organization name	GreenYellow Madagascar
Contact person	Pierre Egot
Title	Managing Director
Address	Immeuble Score Route Digue, Analamanga, Antananarivo 101, Madagascar
Telephone	+262(0)693217391
Email	pegot@greenyellow.fr

1.6 Other Entities Involved in the Project

Organization name	AERA Group
Role in the project	Carbon consultant
Contact person	Alexandre Dunod
Title	Chief Operating Officer
Address	28 Cours Albert 1er, 75008 Paris, France
Telephone	+33 1 42 18 02 02
Email	a.dunod@aera-group.fr

1.7 Ownership

GreenYellow Madagascar has gained project ownership through a production licence and power purchase agreement with Madagascar public utility, JIRAMA.

1.8 Project Start Date

12-July-2018, as the date of commissioning, synchronization and start of GHG emission reductions.

1.9 Project Crediting Period

The project crediting period started on 12-July-2018 and lasts 7 years, until 11-July-2025.

1.10 Project Scale and Estimated GHG Emission Reductions or Removals

Project Scale	
Project	x
Large project	

Year	Estimated GHG emission reductions or removals (tCO _{2e})
2018 (from July 12 th)	11 101
2019	23 751
2020	23 632
2021	23 513
2022	23 393
2023	23 274
2024	23 155
2025 (until July 11 th)	12 199
Total estimated ERs	164 018
Total number of crediting years	7
Average annual ERs	23 431

1.11 Description of the Project Activity

The proposed project consists of setting-up 73,008 solar PV panels with an installed capacity of 20.003 MWp to produce electricity to be exported to RI-Tana grid operated by JIRAMA. This clean electricity development implies a substantial reduction in the production of carbon and its release in the atmosphere, thereby reducing the associated greenhouse impact upon the atmosphere.

The PV modules installed are new and of make Eagle 60 from Jinko Solar. They are of high-efficiency, polycrystalline silicon solar cells with high transmission and tempered glass, which results in module efficiency of up to 16.80%. According to the manufacturer's warranty, the average annual power output degradation of the module shall not exceed 0.5% per year, ending with 80.7% at the end of the 25th year, i.e. implying a life expectancy for at least this duration.² For the Balance of System components, including inverters, lifetime is also exceeding 25 years as per the extendable warranty.

Based on a mean annual global solar radiation of 2,072.1 kWh/m² in the project area and the specifications of the solar PV system (nominal annual output of 1,780 kWh/kWc and performance ratio of 81.6% including

² https://www.jinkosolar.com/product_detail_36.html

all losses & unavailability), the net annual output is expected at 35,612.88 MWh (minus yearly technical degradation of 0,5%, resulting in an average of 32,591 MWh/y over the 7-year crediting period) as provided to banks and/or equity financiers in the financial model, corresponding to a plant load factor of 20.3%³.

In the solar photovoltaic power plant, 14,832 modules JKM 270 PP-60 and 58,176 modules JKM 275 PP-60 are connected in strings of 24 modules, split between 3 inverters/transformers packs located on 5 Ingeteam skids (PTR1 to PTR5). These combined components feed a triple 20kV antenna towards the high-voltage sub-station comprising of an outdoor 20/63kV 17-20MVA transformer and its auxiliaries, protection equipment and control commands. The stepped power is then exported to JIRAMA Interconnected Grid through a 2.86 km overhead transmission line.

Table 1: Characteristics of Solar PV Modules

Manufacturer	Jinko Solar	
Model	Eagle 60 JKM 270 PP-60	Eagle 60 JKM 275 PP-60
Quantity	14,832	58,176
Peak Power (W)	270 W	275 W
Type of cells	Poly-crystalline 156×156mm (6 inch)	
Rated voltage (V_{mpp}) (V)	31.7	32.0
Rated current (I_{mpp}) (A)	8.52	8.61
Efficiency (%)	16.5	16.8
Dimensions (mm)	1650×992×40	

Table 2: Technical data of the inverters

Parameter	Unit	Description
Manufacturer	-	INGECON SUN
Model	-	1220TL
Quantity	-	15
Maximum DC input voltage	V	1,050
Maximum DC input current	A	2,000
AC output power @35 °C / @50 °C	kVA	1,219 kVA / 1,122 kVA
Output frequency range	Hz	50/60
Maximum efficiency	%	98.9
Average power consumption per day	W	1,400

Table 3: Technical data of transformers

Parameter	Unit	Description
Manufacturer	-	SEA

³ cf. 171107_PVSyst Madagascar_Ambatolampy_Note de productible_Ind E

Model	-	A0Bk
Quantity	-	5
Rated power	kVA	2,440 - 3,660
Voltage	V	440

The figure below provides an overview of the full solar PV system. The engineering, procurement and construction of the project is managed by GY Madagascar and its affiliates. All installed technologies, systems and equipment are new.

Figure 2: Solar PV System - From PV modules to grid connection

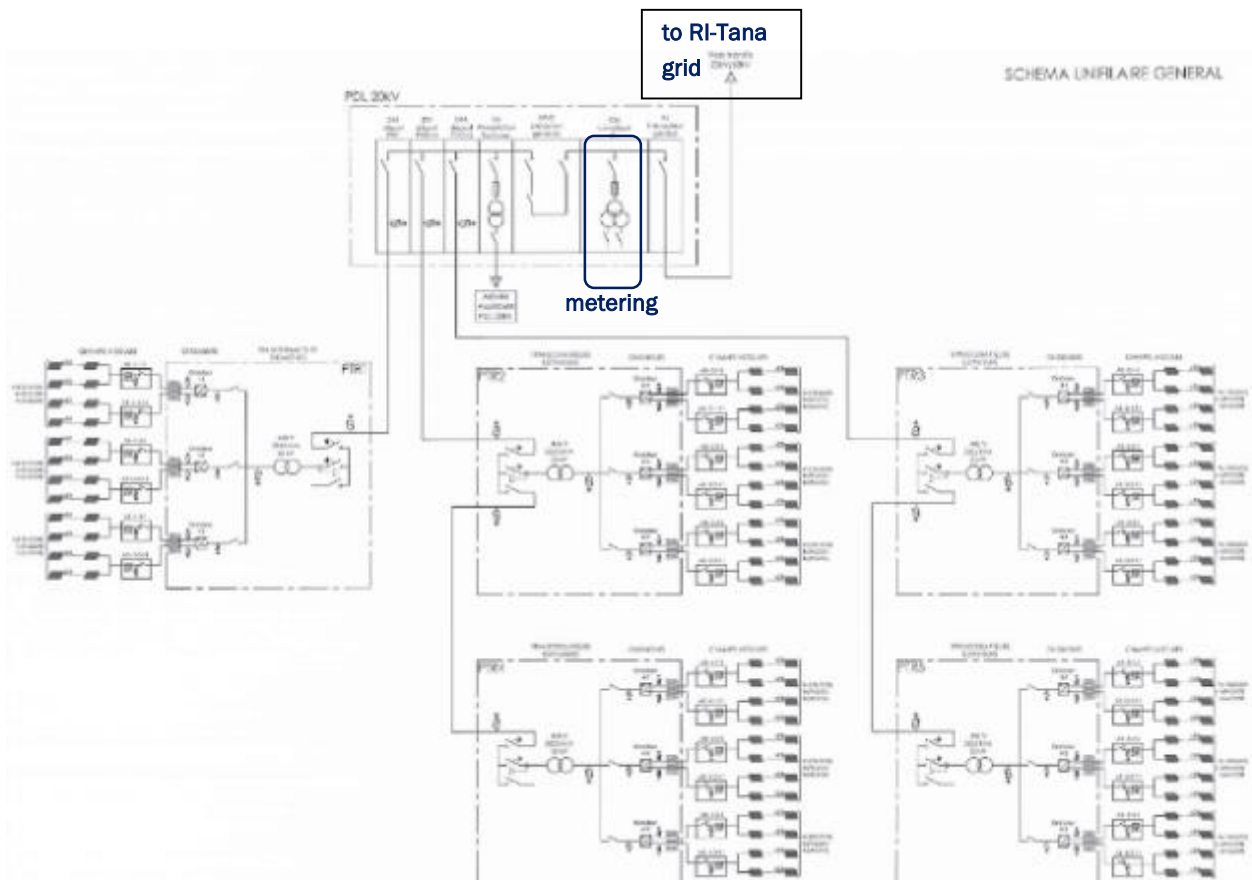

The monitoring equipment is composed of Landis+Gyr Dialog ZMD402/405CT main and back-up meters for import/export, located at the substation, after the auxiliary consumptions draw-down and before the step-up transformer. The main tariff meter's measurement accuracy is class 0.2 S.

1.12 Project Location

Host Party: Madagascar

Region/State/Province: Region of Vakinankaratra, District of Ambatolampy

City/Town/Community: The site is located in Ambatolampy, 90km South of Antananarivo, Madagascar.

The project surface is 28 ha and its geo-coordinates are: Latitude: 19° 29'22"S; Longitude: 47° 26'42"E.

Figure 1: Localisation of project site

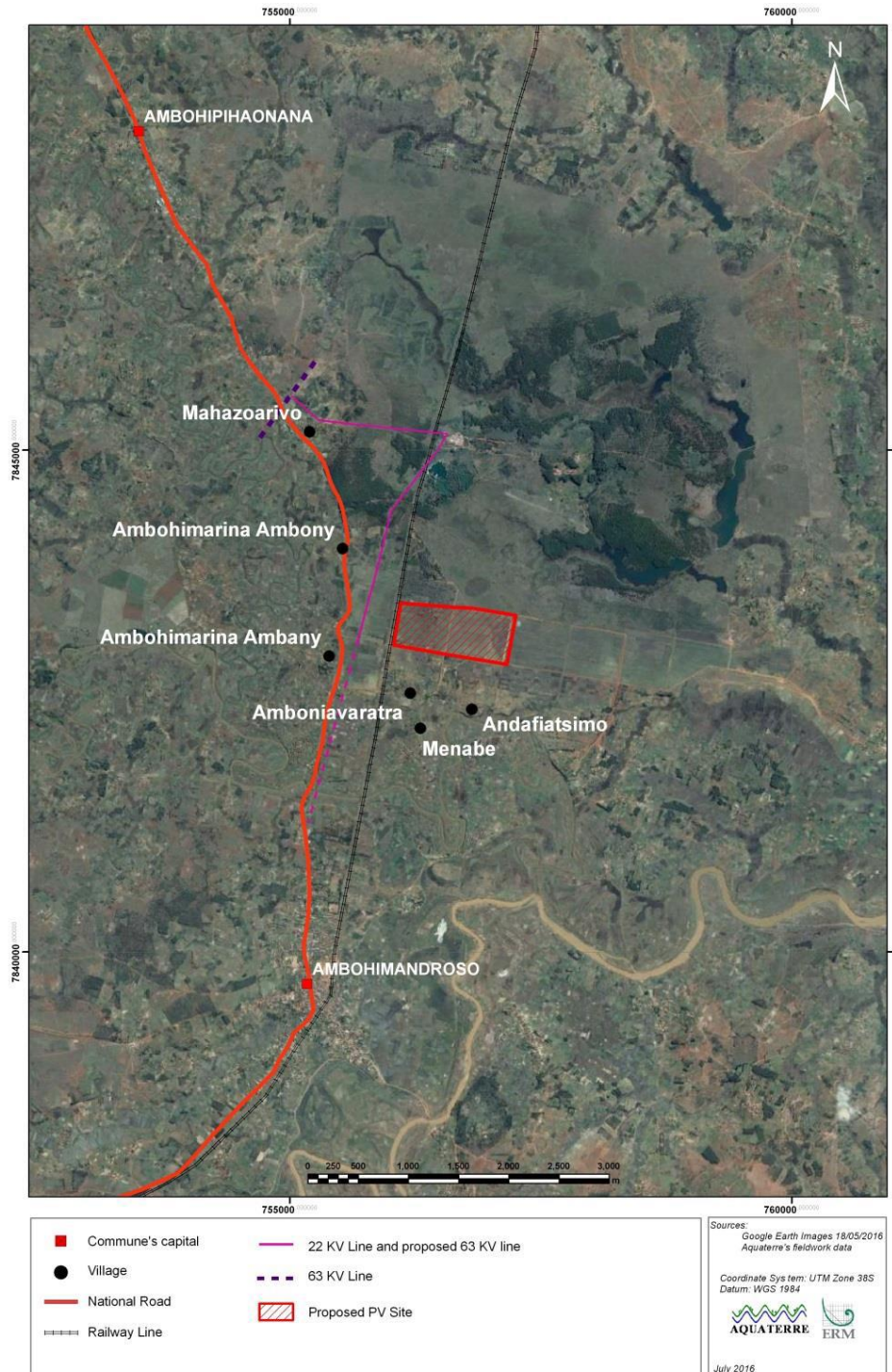

1.13 Conditions Prior to Project Initiation

According to ACM0002 Version 19 and since the project activity is the installation of a new grid-connected renewable power plant (Greenfield) the baseline scenario is the following:

“Electricity delivered to the grid by the project activity would have otherwise been generated by the operation of grid-connected power plants and by the addition of new generation sources, as reflected in the combined margin (CM) calculations described in the “Tool to calculate the emission factor for an electricity system.”

1.14 Compliance with Laws, Statutes and Other Regulatory Frameworks

To date, there are no regulations and policies preventing the implementation of the project activity, which is in line with the regulatory or legal requirements existing for power plants, essentially consisting of the following framework:

- Malagasy Environment Charter N°90.033 that precise the National Policy of the Environment
- Decree N°98-032 concerning the reform of the electricity sector
- MECIE Decree N°99-954 about Environmental Investments Compatibility
- Law n° 2017-020 acting as Electricity Code in Madagascar

1.15 Participation under Other GHG Programs

1.15.1 Projects Registered (or seeking registration) under Other GHG Program(s)

The project is registered under the Clean Development Mechanism⁴ (Project #10481) on 03-May-2019, although its GHG emission reduction will either be claimed under the VCS programme or the CDM programme, never both.

1.15.2 Projects Rejected by Other GHG Programs

The project has not been rejected by any other GHG program.

1.16 Other Forms of Credit

1.16.1 Emissions Trading Programs and Other Binding Limits

The project does not reduce GHG emissions from activities that are included in an emissions trading program or any other mechanism that includes GHG allowance trading.

1.16.2 Other Forms of Environmental Credit

The project has neither sought nor received another form of GHG-related environmental credits.

1.17 Additional Information Relevant to the Project

Leakage Management

⁴ <https://cdm.unfccc.int/Projects/DB/RWTUV1556909746.23/view>

As per approved methodology ACM0002 (Version 19.0), no leakage is considered for the proposed project.

Commercially Sensitive Information

There is no information deemed as commercially sensitive for this project activity.

Sustainable Development

The project participants are confident that the proposed project activity will make significant impact on Madagascar sustainable development.

Greenhouse Gas emissions reduction

The project will generate electricity from a renewable and clean energy source, thus avoiding the dispatch of the same amount of electricity produced by fossil-fuelled power plants to Madagascar grid. Besides, the SO_x emissions from coal-fired power plants would also be reduced.

Development of renewable energy

The project will form a major part of the country's approach to sustainable development also in helping to diversify energy supply away from non-renewable sources, in line with the objectives of the Madagascar Action Plan⁵ launched in 2006 (see development of the infrastructure and the rural areas, protection of the environment), complemented by the New Energy Policy 2015-2030 vision. The project will improve energy self-sufficiency of the country, alleviating the associated risks of price variations.

Employment opportunities

The project contributes to the local employment throughout its building and operation phases, its workforce consisting of up to 80 workers at the peak of construction phase and approximately 10 workers in the operations phase. It will also induce indirect employment by increasing the competitiveness of local industry from reducing the country's dependency on fossil fuels.

Therefore, Madagascar Government is supportive of the project because the development of solar PV power is in accordance with the national criteria for sustainable development and national policies relating to energy resources and the environment, which will push forward the use of renewable and clean energy across the country – where less than one person out of five currently has access to electricity.

Technology transfer

This type of renewable energy project will assist building capacities in the country, through advanced technology transfer from industrialized countries. The project will introduce solar PV technology, methods and skills in the island and demonstrate its applicability and efficiency, thus widening its accessibility. The technology is manufactured by Jinko Solar. The technology for large scale solar PV power generation is still at starting stage of consideration in the country, Ambatolampy 20 MW project being the first large-scale solar PV realization in Madagascar.

⁵ https://www.imf.org/~media/Websites/IMF/imported-publications/external/pubs/ft/scr/2007/fra/_cr0759f.ashx

Further Information

The project participants obtained all necessary clearances; hence no legislative, economic, sectoral, social, environmental, geographic, site-specific risks are anticipated which may have impact on the eligibility of the project activity and the net GHG emission reductions.

2 SAFEGUARDS

2.1 No Net Harm

Not applicable (see registered CDM-PDD)

2.2 Local Stakeholder Consultation

Not applicable (see registered CDM-PDD)

2.3 Environmental Impact

Not applicable (see registered CDM-PDD)

2.4 Public Comments

Not applicable (see registered CDM-PDD)

2.5 AFOLU-Specific Safeguards

Not applicable (see registered CDM-PDD)

3 APPLICATION OF METHODOLOGY

3.1 Title and Reference of Methodology

Not applicable (see registered CDM-PDD)

3.2 Applicability of Methodology

Not applicable (see registered CDM-PDD)

3.3 Project Boundary

Not applicable (see registered CDM-PDD)

3.4 Baseline Scenario

Not applicable (see registered CDM-PDD)

3.5 Additionality

Not applicable (see registered CDM-PDD)

3.6 Methodology Deviations

No methodology deviations were applied.

4 ESTIMATED GHG EMISSION REDUCTIONS AND REMOVALS

4.1 Baseline Emissions

Not applicable (see registered CDM-PDD)

4.2 Project Emissions

Not applicable (see registered CDM-PDD)

4.3 Leakage

Not applicable (see registered CDM-PDD)

4.4 Estimated Net GHG Emission Reductions and Removals

According to the approved methodology ACM0002 ver.19.0, emission reductions are calculated as follows:

$$ER_y = BE_y - PE_y$$

Where:

ER_y = Emission reductions in year y (t CO₂e)

BE_y = Baseline emissions in year y (t CO₂)

PE_y = Project emissions in year y (t CO₂e)

Table 8: Calculation of emission reductions

	Value/Result	Source/reference
Total installed capacity	20 MWc	Project documents
Net electricity delivered to the grid ($EG_{PJ,y}$)	32,591 MWh/yr	Project documents (nominal average) [$EG_{PJ,y} = EG_{facility,y}$]
Grid emission factor ($EF_{grid,CM,y}$)	0.6703 tCO _{2e} /MWh	CDM-PDD section B.6.1.
Baseline emissions (BE_y)	23,431 tCO _{2e}	Section 3.1 $BE_y = EG_{PJ,y} \cdot EF_{grid,CM,y}$
Project emissions (PE_y)	0 tCO _{2e}	Section 3.2
Emission reductions (ER_y)	23,431 tCO _{2e}	$ER_y = BE_y - PE_y$

Table 9: Summary of emission reductions

Year	Estimated baseline emissions or removals (tCO _{2e})	Estimated project emissions or removals (tCO _{2e})	Estimated leakage emissions (tCO _{2e})	Estimated net GHG emission reductions or removals (tCO _{2e})
2018 (from July 12th)	11 101	-	-	11 101
2019	23 751	-	-	23 751
2020	23 632	-	-	23 632
2021	23 513	-	-	23 513
2022	23 393	-	-	23 393
2023	23 274	-	-	23 274
2024	23 155	-	-	23 155
2025 (until July 11th)	12 199	-	-	12 199
Total	164 018	-	-	164 018

5 MONITORING

5.1 Data and Parameters Available at Validation

Not applicable (see registered CDM-PDD)

5.2 Data and Parameters Monitored

Not applicable (see registered CDM-PDD)

5.3 Monitoring Plan

Not applicable (see registered CDM-PDD)

6 ACHIEVED GHG EMISSION REDUCTIONS AND REMOVALS

6.1 Data and Parameters Monitored

Data / Parameter	$EG_{\text{facility},y}$																					
Data unit	MWh/yr																					
Description	Quantity of net electricity generation supplied by the project plant/unit to the grid in year y																					
Value applied:	2018 15,029	2019 31,958	2020 9,478	Total 56,465																		
Comments	<p>Electricity outputs is electronically recorded, stored and invoiced monthly to JIRAMA by GY Madagascar, based on main meter below (or back-up in case of main meter unavailability or default).</p> <p>The measurement devices of net electrical energy delivered to RI-Tana grid are both located before 20/63kV transformer at JIRAMA substation and feature the following specifications:</p> <table border="1"> <tr> <td>Meter designation:</td> <td>Main</td> <td>Back-up</td> </tr> <tr> <td>Meter ownership:</td> <td>JIRAMA</td> <td>GreenYellow</td> </tr> <tr> <td>Make:</td> <td>Landis+Gyr Dialog</td> <td>Landis+Gyr</td> </tr> <tr> <td>Model:</td> <td>ZMD402CT</td> <td>ZMD405CT</td> </tr> <tr> <td>Accuracy class:</td> <td>0.2S ($\pm 0.2\%$)</td> <td>0.5S ($\pm 0.2\%$)</td> </tr> <tr> <td>Serial number:</td> <td>38752127</td> <td>95766898</td> </tr> </table>				Meter designation:	Main	Back-up	Meter ownership:	JIRAMA	GreenYellow	Make:	Landis+Gyr Dialog	Landis+Gyr	Model:	ZMD402CT	ZMD405CT	Accuracy class:	0.2S ($\pm 0.2\%$)	0.5S ($\pm 0.2\%$)	Serial number:	38752127	95766898
Meter designation:	Main	Back-up																				
Meter ownership:	JIRAMA	GreenYellow																				
Make:	Landis+Gyr Dialog	Landis+Gyr																				
Model:	ZMD402CT	ZMD405CT																				
Accuracy class:	0.2S ($\pm 0.2\%$)	0.5S ($\pm 0.2\%$)																				
Serial number:	38752127	95766898																				

6.2 Baseline Emissions

The monitoring period for which GHG emission reductions were achieved spans 12/07/2018 to 30/04/2020. Baseline emissions are calculated according to §4.1 methodological approach as the product of (i) the quantity of net electricity generation that is produced and fed into the grid as a result of the implementation of the project activity in year y ($EG_{facility,y} = \text{Exports} - \text{Imports}$, in MWh/yr) and (ii) the combined margin CO₂ emission factor for grid connected power generation in year y ($EF_{grid,CM,y}$):

$$BE_y = EG_{PJ,y} \times EF_{grid,CM,y}$$

Where:

BE_y	Baseline emissions in year y (t CO ₂ /yr)
$EG_{PJ,y}$	Quantity of net electricity generation that is produced and fed into the grid as a result of the implementation of the project activity in year y (MWh/yr)
$EF_{grid,CM,y}$	Combined margin CO ₂ emission factor for grid connected power generation in year y calculated using the latest version of the “Tool to calculate the emission factor for an electricity system” (t CO ₂ /MWh)

$EG_{PJ,y} = EG_{facility,y}$ i.e. the quantity of net electricity generation supplied by the project plant to the grid, as monitored and displayed below on a monthly basis.

$EF_{grid,CM,y} = 0.6703$ tCO₂/MWh, as the Project Proponent have calculated, the DOE validated and the CDM-EB registered.

Year	Exports	Imports	$EG_{facility,y}$	$EF_{grid,CM,y}$	BE_y
	MWh	MWh	MWh	tCO ₂ /MWh	t CO ₂
juil-18	957 370	4 140	953	0,6703	639
août-18	3 108 940	3 440	3 106	0,6703	2 082
sept-18	3 171 550	2 150	3 169	0,6703	2 124
oct-18	3 216 780	1 230	3 216	0,6703	2 155
nov-18	1 927 210	1 300	1 926	0,6703	1 291
déc-18	2 660 790	1 470	2 659	0,6703	1 783
janv-19	2 456 900	2 010	2 455	0,6703	1 646
févr-19	2 547 020	2 200	2 545	0,6703	1 706
mars-19	2 622 970	2 880	2 620	0,6703	1 756
avr-19	2 654 630	1 890	2 653	0,6703	1 778
mai-19	2 328 640	2 410	2 326	0,6703	1 559
juin-19	1 690 850	2 680	1 688	0,6703	1 132
juil-19	2 541 360	3 650	2 538	0,6703	1 701
août-19	3 027 010	3 300	3 024	0,6703	2 027
sept-19	2 860 290	2 010	2 858	0,6703	1 916
oct-19	3 153 780	1 810	3 152	0,6703	2 113

nov-19	2 976 130	840	2 975	0,6703	1 994
déc-19	3 126 240	1 680	3 125	0,6703	2 094
janv-20	2 202 730	880	2 202	0,6703	1 476
févr-20	2 474 460	1 500	2 473	0,6703	1 658
mars-20	2 478 520	1 320	2 477	0,6703	1 660
avr-20	2 327 740	1 360	2 326	0,6703	1 559
TOTAL	56 511 910	46 150	56 465,8		37 847

6.3 Project Emissions

No project emissions are expected as the project activity only involves renewable electricity generation from the solar power plant. Hence according to ACM0002 guidelines PE_y = 0.

6.4 Leakage

As stated in the applicable methodology, no leakage emissions are considered, therefore LE_y = 0.

6.5 Net GHG Emission Reductions and Removals

The monitoring period for which GHG emission reductions were achieved spans 12/07/2018 to 30/04/2020, split by vintage as follows:

Year	Baseline emissions or removals (tCO ₂ e)	Project emissions or removals (tCO ₂ e)	Leakage emissions (tCO ₂ e)	Net GHG emission reductions or removals (tCO ₂ e)
2018 (from July 12 th)	10 073	-	-	10 073
2019	21 421	-	-	21 421
2020 (until April 30 th)	6 353	-	-	6 353
Total	37 847	-	-	37 847

