

MONITORING REPORT FORM (CDM-MR) *
Version 02.0 - in effect as of: 23/11/2012

CONTENTS

- A. General description of the project activity
 - A.1. Brief description of the project activity
 - A.2. Project participants
 - A.3. Location of the project activity
 - A.4. Technical description of the project
 - A.5. Title, reference and version of the baseline and monitoring methodology applied to the project activity
 - A.6. Registration date of the project activity
 - A.7. Crediting period of the project activity and related information
 - A.8. Name of responsible person(s)/entity(ies)

- B. Implementation of the project activity
 - B.1. Implementation status of the project activity
 - B.2. Revision of the monitoring plan
 - B.3. Request for deviation applied to this monitoring period
 - B.4. Notification or request of approval of changes

- C. Description of the monitoring system

- D. Data and parameters monitored
 - D.1. Data and parameters used to calculate baseline emissions
 - D.2. Data and parameters used to calculate project emissions
 - D.3. Data and parameters used to calculate leakage emissions
 - D.4. Other relevant data and parameters

- E. Emission reductions calculation
 - E.1. Baseline emissions calculation
 - E.2. Project emissions calculation
 - E.3. Leakage calculation
 - E.4. Emission reductions calculation
 - E.5. Comparison of actual emission reductions with estimates in the registered CDM-PDD
 - E.6. Remarks on difference from estimated value
 - E.7. Actual emission reductions or net anthropogenic GHG removals by sinks during the first commitment period and the period from 1 January 2013 onwards

MONITORING REPORT
Version 2.2, 30/03/2013
Biogas Utilization Project In Zhejiang Jingxing Paper Joint Stock Co. Ltd.
5042
The First Verification: 28/07/2011-31/08/2012

SECTION A. General description of the project activity

A.1. Brief description of the project activity: >>

>>

The main purpose of the project activity (hereafter also referred to as Project) is to install a **biogas-capturing device and a biogas based electricity generation** system in the existing wastewater treatment systems at the paper mill of Zhejiang Jingxing Paper Joint Stock Co. Ltd. Zhejiang Jingxing Paper Joint Stock Co. Ltd. has two production lines with total paper production capacity of 600,000 tons per year. The production process in this monitoring period produced 6,861,146 m³ of wastewater, which was sent to an onsite wastewater treatment system. As a part of the treatment process, the anaerobic digester system released a methane rich biogas. The current anaerobic wastewater treatment system reduced the COD concentration of the wastewater from 2,801 mg/l to 1282 mg/l. After the anaerobic digesters the wastewater passes through an aerobic treatment stage before it was discharged into the municipal wastewater treatment plant for further treatment through a channel.

The scenario existing prior to the start of the implementation of the project activity

Anaerobic digesters integrated generate 13,000~15,000m³ of biogas everyday and will be piped to the biogas power plant (3x500kW capacity with additional 500kW as standby capacity). The existing wastewater treatment systems at the paper mill of Zhejiang Jingxing Paper Joint Stock Co. Ltd. have no biogas recovery devices and the methane-rich gas was released to the atmosphere in the baseline scenario.

Construction Started in Feb. 4th. 2009, commissioning started in June 23rd. 2009 and continued operation started in October 8th. 2009. There is no long-term overhaul and equipment exchange during the monitoring period.

The project activity will lead to green house gas (GHG) emission reductions in a two fold manner: (a) it will avoid methane emissions by capturing the biogas and using it as a fuel, and (b) it will displace fossil fuel based electricity from the Grid. In this monitoring period, the registered project activity reduced 31,793 tCO₂e by capturing the biogas and around 5,453 tCO₂e through displacement of electricity from the grid. The total amount of emission reductions of this monitoring period is 37,246tCO₂e.

A.2. Project Participants

>>

Party involved ((host) indicates a host Party)	Private and/or public entity(ies) project participants (as applicable)	Indicate if the Party involved wishes to be considered as project participant (Yes/No)
P.R China	Zhejiang Jingxing Paper Joint Stock Co.,Ltd.	No
Switzerland	Swiss Carbon Assets Ltd.	No

A.3. Location of the project activity:

>> The proposed project is located at Pinghu, Jiaxing Municipality, Zhejiang Province, People’s Republic of China. The project has geographical coordinates of E120.9501 and N30.6992¹.



Figure 1. Location of the project activity

A.4. Technical description of the project

>>

Technology

Figure 2 in Section B.1 shows the schematic diagram of the project. The proposed project installs a biogas recovery and utilization system to the existing wastewater treatment facilities. It consists of a biogas recovery system (two biogas storage tanks and one flare device at plant 2, one biogas pocket and flare device at plant 1), a biogas purification system (a sulphur removal unit), and a power generation system at Plant 2 (four sets of methane/biogas fired internal combustion engines and generators have been installed).

Biogas recovery system

Biogas from the existing wastewater treatment systems is collected by the project’s recovery system in Plant 1 (where one biogas pocket is installed with flare device for emergency) and Plant 2 respectively. Biogas collected from Plant 1 is piped to Plant 2 (where two biogas storage tanks are installed with flare device for emergency). Biogas from Plant 1 and 2 is mixed together in Plant 2’s storage tanks before it goes to the sulphur removal system and gas pre-processing system. And finally the treated biogas is utilized at the power generations at the site of Plant 2.

Sulphur removal system

¹ Location of the powerhouse, which is the center of the project site.

A wet scrubber system has been applied to remove the sulphur in the captured biogas effectively. The H₂S containing gas enters the absorption section and is washed by scrubbing liquid. The liquid has an alkaline nature and absorbs the H₂S. The biogas exits the top of the absorber virtually free of H₂S. The sulfide containing liquid flows into the bioreactor. In the reactor bacteria oxidize the sulfide with oxygen. The sulfur is then removed by use of a settler. The sulfide free liquid returns to the absorption section.

Power generation system

The biogas desulphurized has been taken into the gas engines for electricity generation directly. The total installed capacity of the power generation system is 2.0 MW, containing four 500kw gas engines (one is for back-up use). The electricity produced is fully consumed on site to support the generation demand of the wastewater treatment plant.

A.5. Title, reference and version of the baseline and monitoring methodology applied to the project activity:

>>

Methane avoidance component:

The approved CDM small-scale baseline and monitoring methodology AMS III.H “Methane Recovery in Wastewater Treatment” (Version 15) is applied to the methane avoidance component of the project activity.

Electricity generation component:

The approved CDM small-scale baseline and monitoring methodology AMS-I.F “Renewable electricity generation for captive use and mini-grid” (Version 01) is applied to the electricity generation component of the project activity.

For calculation of the combined margin baseline emission factor, the methodological tool “Tool to calculate the emission factor for an electricity system” (Version 02) is used.

A.6. Registration date of the project activity:

>>28/07/2011

A.7. Crediting period of the project activity and related information (start date and choice of crediting period):

>>

The start date of the crediting period is changed from 01/10/2011 to 28/07/2011, and this has been accepted by the Board. The crediting period is fixed as 10 year (28/07/2011 to 27/07/2021).

A.8. Name of responsible person(s)/entity(ies):

>>

Mr Sun Mingming and Mr. Yang Xuan

Address: Unit 2506 A, China Central Building T3, Jianguo Road 77, Chaoyang District, 100025, Beijing

Telephone: +86 10 84549953

Email: m.sun@southpolecarbon.com

SECTION B. Implementation of the project activity

B.1. Implementation status of the project activity

>>

Construction Started: Feb. 4th. 2009

Commissioning started: June 23rd. 2009

Continued operation started: October 8th. 2009

There is no long-term overhaul and equipment exchange during the monitoring period.

Technology

Figure 2 in Section B.1 shows the schematic diagram of the project. The proposed project installs a biogas recovery and utilization system to the existing wastewater treatment facilities. It consists of a biogas recovery system (two biogas storage tanks and one flare device at plant 2, one biogas pocket and flare device at plant 1), a biogas purification system (a sulphur removal unit), and a power generation system at Plant 2 (four sets of methane/biogas fired internal combustion engines and generators have been installed).

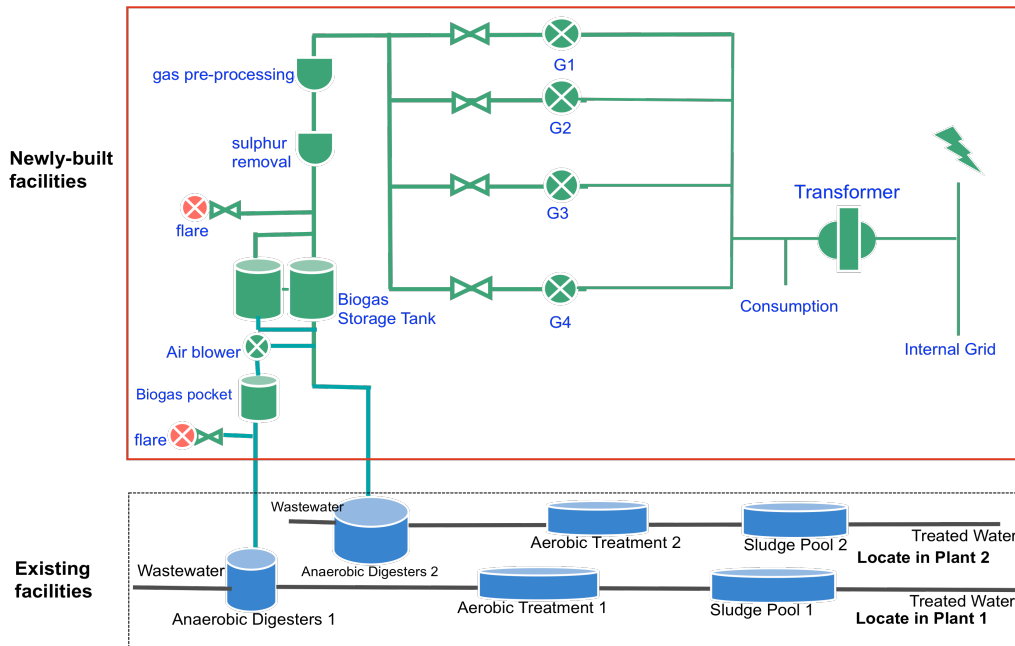

Figure 2. Schematic Diagram of the Project

Following table 1 and 2 shows the key parameters of the generators

Table 1 Key parameters of Project (Generators)

Model	500GF1	TH500-12/1180
Unit	2*	2*
Manufacturer	Shengli Power Machinery Co. Ltd.	Zibo Diesel Engine New Energy Co. Ltd.
Engine Speed	1000rpm	500 rpm
Rated Frequency	50Hz	50 Hz
Rated Voltage	400V	400V
Plant Load factor	0.83 ²	
Power factor	0.8	0.8
Operation life time	15	15
Generator Power (kW, at 100% load)	500KW	500KW

- Note: One of the generators serves as a back-up generator.

Table 2 Key parameters of Project (Sulphur removal)

Model	THIOPAQ
Unit	1
Manufacturer	Paques Environmental Technology (Shanghai) Co., Ltd.

² Derived from FSR approval from local government. According to the FSR approval, the approved yearly electricity production is 10,914 MWh. With yearly operation hours of 7276 hours (= 10914 MWh/1.5 MW), the Plant Load Factor is 83% (= 7276 hours /8760 hours).

Model	THIOPAQ
Designed capacity	20,000Nm ³ /d

B.2. Revision of the monitoring plan

>>

No revisions of the monitoring plan.

B.3. Request for deviation applied to this monitoring period

>>

No deviation applied.

B.4. Notification or request of approval of changes

>>

Not applicable.

SECTION C. Description of the monitoring system

>>

Data collection procedure

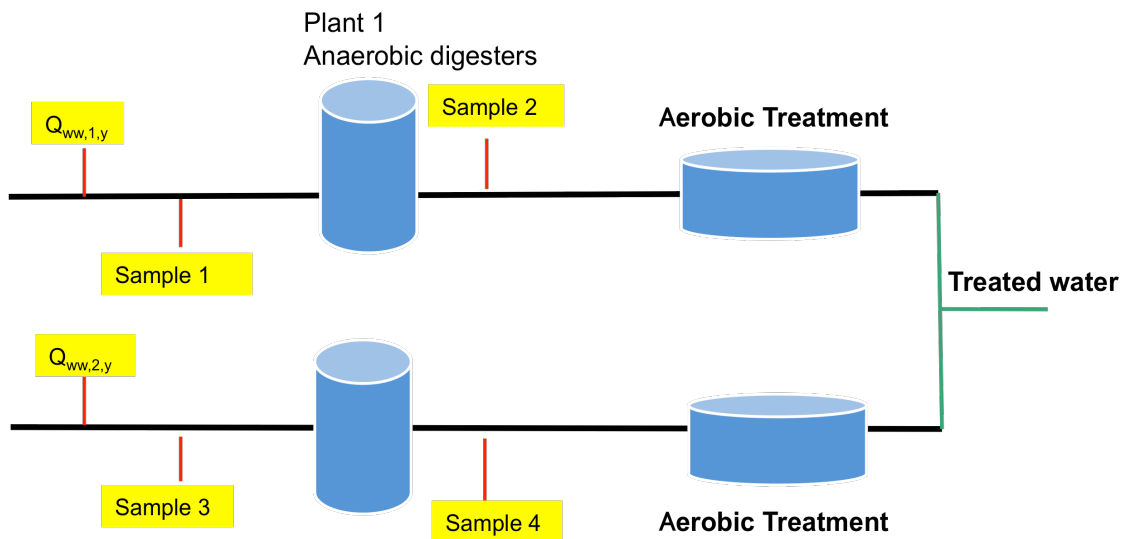

Figure 3 Schematic Diagram of wastewater flow

Data generation:

The project owner reads the power meters daily. Auto-electronic devices have been installed in the project site. As showed in Figure 3, two flow meters were installed at the location $Q_{ww,1,y}$ and $Q_{ww,2,y}$, the project owner reads the flow meter on daily based. The analysis of COD content before and after the anaerobic digesters will be sampled and measured through lab test based on GB11914 (Monitoring and Analyzing of Water and Wastewater). Therefore, the data of COD removed will be the difference of these two values. Since there are two anaerobic digesters involved in the project activity, the test will be done separately for the COD content after each reactor. Based on Figure 3 above, the wastewater from sample 1 and 3 will be the basis for testing the COD content of the wastewater before digesters; Sample 2 and 4 will be used for testing COD content of wastewater after anaerobic digesters.

As showed in Figure 5 below, another three biogas flow meters have been installed before the entrance of biogas generator and two flaring system respectively. The monitoring data of BG_{burt} , $FV_{RG,h,1}$ and $FV_{RG,h,2}$ are collected by auto-electronic devices on hourly basis. Additionally, the data of methane content are collected automatically by gas analyzers on hourly basis. The online temperature gauges monitors the temperature of the biogas flared.

Data recording:

Monitoring data for both baseline and project emission calculations (including PE_{flare}) are recorded by the qualified employees on-site using a designed form periodically. Data of power generation, biogas (flow, fraction of methane) are also stored in electronic form periodically.

Data aggregation:

Monitoring data is collected and aggregated by the each corresponding team leader every month and stored properly. The CDM project manager of Zhejiang Jingxing Paper Joint Stock Co. Ltd rechecks and collects the monitoring data from each operation team leaders and sends them to Swiss Carbon Assets Ltd.

Calculation:

Please see the details in Section D and E, or refer to the calculation spread sheet.

Calibration and Accuracy of meters:

Please refer to Table 3 below.

Table 3: Detailed meter information

<i>Meter Measuring</i>	Accuracy (%)	Serial number	Date of Last calibration	Calibration date jing	Valid until	Certificate No.
$Q_{ww,1y}$	1.0	85000718000	06/2007	14/08/2012	13/08/2014	RL-2012080119
$Q_{ww,2y}$	1.0	AD0701015	06/2007	14/08/2012	13/08/2014	RL-2012080118
$BG_{burnt,y}$	1.5	11095105	09/2009	15/05/2012	14/05/2014	2712050356001
$W_{CH_4, fuelled,y}$	5.0	741544	10/2009	17/08/2012	16/08/2013	NH-201216753
$FV_{RG,h,1}$	1.5	B3-11M175	09/2009	16/02/2012	15/02/2015	RL-2012020025
$FV_{RG,h,2}$	1.5	11095090	06/2009	16/02/2012	15/02/2014	RL-2012020027
$fv_{CH_4, RG, h, 2}$	5.0	741543	10/2009	17/08/2012	16/08/2013	NH-201216754
$fv_{CH_4, RG, h, 1}$	5.0	776518	10/2009	24/10/2012	23/10/2013	NH-201222085
EG_y	0.5S	KKK2090204	11/02/2009	14/12/2012	13/12/2017	RD-2012120331
<i>Online temperature gauge³</i>	3%	-	08/2009	Not calibrated	Not calibrated	Not calibrated

Organizational Structures, Roles and responsibilities

Management Structure

Following figure shows basic management structure of the Project. Project managers of Swiss Carbon Asset Management Co., Ltd. will make direct communication with project manager of Zhejiang Jingxing Paper Joint Stock Co., Ltd. regarding monitoring requirements of CDM. The project manager directly leads two teams, e.g. wastewater treatment plant team and power generation team. Team leaders report to project managers and manage team of operators. System maintenance, repairing and calibration service will be provided by a department of the plant on demand of the Project.

³ For biogas flared, as the temperature meter is not calibrated, the flaring efficiency is assumed to be 0% for conservativeness. That means whenever flare is on, all emission has been accounted as project emissions, and therefore the baseline emissions from biogas flared is 0.

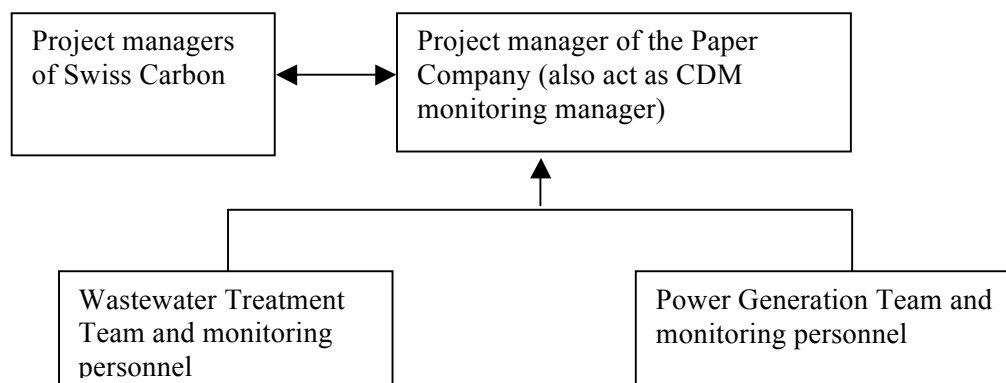

Emergency procedures for the monitoring system

The site manager will notify the manufacturer and the equipment maintenance team in case there is doubt about the correct functioning of the meters mentioned in the monitoring plan. In that case, manufacturer or the maintenance team will check, repair and where necessary replace the meters.

Emission reductions are generally calculated based on amount of biogas recovered and power generation. While, in case of emergency or malfunctions in major meters, following measures will be taken for ER calculation:

- In case of emergency/malfunction in generators, a flare will start working and emission reductions will be calculated as zero during this period for simplicity and conservative;
- Proposed project will install backup meters for power generation;
- Ratio between power generation and biogas amount will be used in case of biogas monitoring is in abnormal conditions. Proper conservative approach will be taken.

Location of meters and line diagram

Please refer to Table 4 for detailed location of the meters. Figure 4 illustrates for the electricity line connection and relevant monitoring of electricity generation. Figure 5 demonstrates the monitoring of biogas recovery.

Table 4: Monitored parameters and locations

Symbol	Name in Section D.2	Descriptions and locations	Monitoring equipment
E	EG_{BLy}	Quantity of net electricity displaced as a result of the implementation of the project activity in year y . The meter installed on the line before exported to the grid, and please refer to the locations for details in figure5 below.	Electricity meter
F	$BG_{burnt,y}$ $FV_{RG,h,1}$ $FV_{RG,h,2}$	Amount of biogas combusted/flared in the year y . (normalized flow). As showed in figure 5 below, the meters are installed at the entrance to biogas generator system and flaring system respectively.	Flow meter
C	$W_{CH_4, fuelled,y}$ $fV_{CH_4, RG,h,1}$ $fV_{CH_4, RG,h,2}$	Methane content that biogas fuelled at entrance of generators as well as the methane content that the biogas flared at both Plant 1 and 2. The locations of the meters can be found in figure 5 below.	Gas analyser
F _{ww}	$Q_{ww,1,y}$ $Q_{ww,2,y}$	Volume of wastewater treated in the year “ y ”(both plant 1 and 2). The meters are installed on the pipe just before the anaerobic digesters, and please refer to figure 5 for the locations.	Water flow meter
COD	$COD_{ww,untreated,1,y}$ $COD_{ww,untreated,2,y}$ $COD_{ww,treated,1,y}$ $COD_{ww,treated,2,y}$	COD content removed through the anaerobic reactors (both Plant 1 and 2).. As showed in figure 3 and 5, samples are taken from the pipe both before and after each anaerobic digester.	Sampling and laboratory test by titrimetric or photometric methods

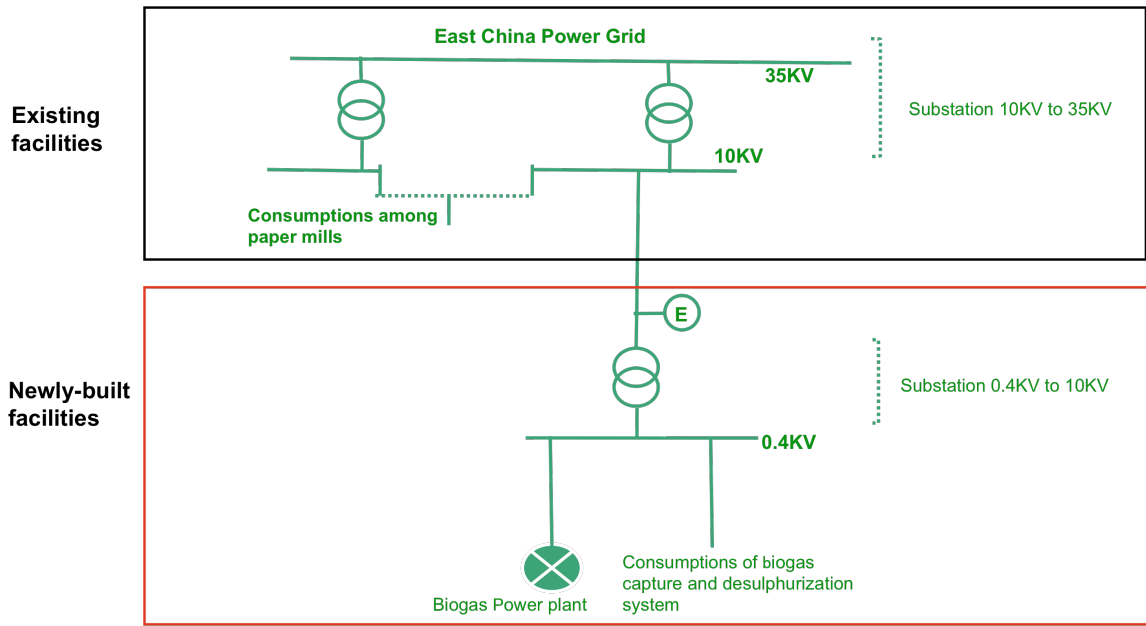

Figure 4. Line Connection Diagram

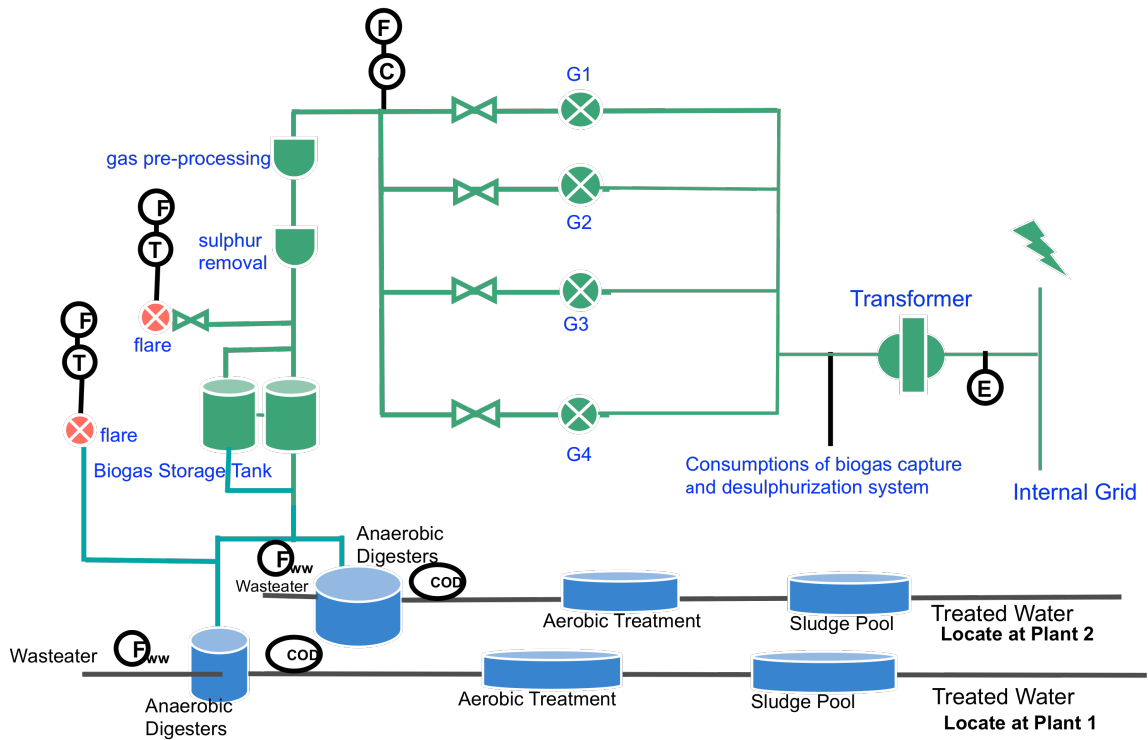

Figure 5 Monitor of biogas recovery and their installation positions

SECTION D. Data and parameters

D.1. Data and parameters determined at registration and not monitored during the monitoring period, including default values and factors

1) Methane avoidance component:

Data / Parameter:	$B_{o,ww}$
Data unit:	kg CH ₄ /kg COD
Description:	Methane producing capacity of the wastewater
Source of data used:	Methodology's default value
Value(s) :	0.25 kg CH ₄ /kg COD
Indicate what the data are used for (Baseline/ Project/ Leakage emission calculations)	Baseline and project emissions.
Additional comment:	As per AMS.III.H Version 15, the IPCC default value of 0.25 kg CH ₄ /kg COD was corrected to take into account the uncertainties.

Data / Parameter:	GWP_{CH_4}
Data unit:	-
Description:	Global Warming Potential for methane
Source of data used:	IPCC: Climate Change 1995, The Science of Climate Change: Summary for Policymakers and Technical Summary of the Working Group I Report, pg. 26
Value(s) :	21
Indicate what the data are used for (Baseline/ Project/ Leakage emission calculations)	Baseline and project emissions.
Additional comment:	

Data / Parameter:	MCF
Data unit:	Fraction
Description:	methane correction factor for the wastewater treatment system
Source of data used:	2006 IPCC Guidelines for National Greenhouse Gas Inventories (Volume 5, Chapter 6), value for anaerobic reactors
Value(s) :	$MCF_{ww,treatment,PJ,k,y} = 0.8$ (for calculation of project emissions) $MCF_{ww,treatment,BL} = 0.8$ (for calculation of baseline emissions)
Indicate what the data are used for (Baseline/ Project/ Leakage emission calculations)	Baseline and project emissions.
Additional comment:	As per AMS.III.H Version 15, the higher IPCC value is used for calculation of project emissions and the lower value for baseline emissions as a conservative measure.

Data / Parameter:	UF_{BL}
Data unit:	Factor
Description:	Model correction factor to account for model uncertainties
Source of data used:	AMS III.H/ Version 15
Value(s) :	0.89
Indicate what the data are used for (Baseline/ Project/ Leakage emission calculations)	According to the AMS III.H, Correction factor will be used for estimation of baseline emissions.
Additional comment:	

Data / Parameter:	UF_{PJ}
Data unit:	Factor
Description:	Model correction factor to account for model uncertainties
Source of data used:	AMS III.H/ Version 15
Value(s) :	1.12
Indicate what the data are used for (Baseline/ Project/ Leakage emission calculations)	According to the AMS.III.H, Correction factor will be used for estimation of project activity emissions.
Additional comment:	

Data / Parameter:	CFE_{ww}
Data unit:	Fraction
Description:	Capture efficiency of the biogas recovery equipment in the wastewater treatment systems
Source of data used:	AMS IIIH Version 15
Value(s) :	0.9
Indicate what the data are used for (Baseline/ Project/ Leakage emission calculations)	Calculation of project emissions.
Additional comment:	

Data / Parameter:	EF_{grid,CM,y}
Data unit:	tCO ₂ /MWh
Description:	Combined margin CO ₂ emission factor of East China Power Grid in year y
Source of data used:	<i>China Electric Power Yearbook 2007-2009, China Energy Statistics Yearbook 2008, 2006 IPCC Guidelines for National Greenhouse Gas Inventories</i>
Value(s) :	0.7690
Indicate what the data are used for (Baseline/ Project/ Leakage emission calculations)	Baseline emissions.
Additional comment:	Based on combined margin calculation of OM and BM of East China Power Grid. Weighting of OM and CM are both 50%.

D.2. Data and parameters monitored									
<i>(Copy this table for each data and parameter. To report multiple values, a table may be used)</i>									
Data / Parameter:	Q_{ww,I,y}								
Data unit:	m ³ /yr								
Description:	Volume of wastewater treated in plant 1 the year “y”								
Measured /Calculated /Default:	Measured by flow meter								
Source of data:	Flow meter records/operation logbook								
Value(s) of monitored parameter:	<table border="1"> <thead> <tr> <th>Unit: m³/year</th> <th>Plant 1</th> </tr> </thead> <tbody> <tr> <td>2011</td> <td>533,963</td> </tr> <tr> <td>2012</td> <td>973,828</td> </tr> <tr> <td>Sub-total</td> <td>1,507,791</td> </tr> </tbody> </table>	Unit: m ³ /year	Plant 1	2011	533,963	2012	973,828	Sub-total	1,507,791
Unit: m ³ /year	Plant 1								
2011	533,963								
2012	973,828								
Sub-total	1,507,791								
Indicate what the	Baseline and project emissions calculations.								

data are used for (Baseline/ Project/ Leakage emission calculations)													
Monitoring equipment (type, accuracy class, serial number, calibration frequency, date of last calibration, validity)	<table border="1"> <thead> <tr> <th>Type</th> <th>Accuracy class</th> <th>Serial Number</th> <th>Calibration frequency</th> <th>Date of delayed calibration</th> <th>Validity</th> </tr> </thead> <tbody> <tr> <td>50W2H-HD0A1AA0A AAA</td> <td>1.0</td> <td>85000718000</td> <td>Two years</td> <td>14/08/2012</td> <td>13/08/2014</td> </tr> </tbody> </table>	Type	Accuracy class	Serial Number	Calibration frequency	Date of delayed calibration	Validity	50W2H-HD0A1AA0A AAA	1.0	85000718000	Two years	14/08/2012	13/08/2014
Type	Accuracy class	Serial Number	Calibration frequency	Date of delayed calibration	Validity								
50W2H-HD0A1AA0A AAA	1.0	85000718000	Two years	14/08/2012	13/08/2014								
Measuring/ Reading/ Recording frequency:	Monitored continuously, read and recorded on daily based.												
Calculation method (if applicable):	Not applicable.												
QA/QC procedures applied:	<ul style="list-style-type: none"> ▪ Trained and qualified staff is responsible for recording data from the meter ▪ Meter will be calibrated periodically according to relevant national standards 												
Additional comment	As per Clean development mechanism validation and verification standard version 03.0, as the delayed calibration reports shows that both the errors are smaller than the maximum permissible errors (1%) of the flow meters, therefore, maximum permissible error (1%) is applied for the calculations of the volume of wastewater treated. For the baseline emission calculations, the monitored data will be corrected with 99% (100%-1%), while for the project emission calculations, the result will be corrected with 101%(100%+1%) for conservativeness.												

Data / Parameter:	$Q_{ww,2,y}$								
Data unit:	m ³ /yr								
Description:	Volume of wastewater treated in plant 2 the year “y”								
Measured /Calculated /Default:	Measured by flow meter								
Source of data:	Flow meter records/operation logbook								
Value(s) of monitored parameter:	<table border="1"> <thead> <tr> <th>Unit: m³/year</th> <th>Plant 2</th> </tr> </thead> <tbody> <tr> <td>2011</td> <td>1,981,992</td> </tr> <tr> <td>2012</td> <td>3,371,363</td> </tr> <tr> <td>Sub-total</td> <td>5,353,355</td> </tr> </tbody> </table>	Unit: m ³ /year	Plant 2	2011	1,981,992	2012	3,371,363	Sub-total	5,353,355
Unit: m ³ /year	Plant 2								
2011	1,981,992								
2012	3,371,363								
Sub-total	5,353,355								
Indicate what the data are used for (Baseline/ Project/ Leakage emission calculations)	Baseline and project emissions calculations.								
Monitoring equipment (type, accuracy class, serial number, calibration)	<table border="1"> <thead> <tr> <th>Type</th> <th>Accuracy class</th> <th>Serial Number</th> <th>Calibration frequency</th> <th>Date of delayed calibration</th> <th>Validity</th> </tr> </thead> <tbody> </tbody> </table>	Type	Accuracy class	Serial Number	Calibration frequency	Date of delayed calibration	Validity		
Type	Accuracy class	Serial Number	Calibration frequency	Date of delayed calibration	Validity				

frequency, date of last calibration, validity)	AE340MG -ZR1-1SJ	1.0	AD07010 15	Two years	14/08/2012	13/08/2014
Measuring/ Reading/ Recording frequency:	Monitored continuously, read and recorded on daily based.					
Calculation method (if applicable):	Not applicable.					
QA/QC procedures applied:	<ul style="list-style-type: none"> ▪ Trained and qualified staff is responsible for recording data from the meter ▪ Meter will be calibrated periodically according to relevant national standards 					
Additional comment	As per Clean development mechanism validation and verification standard version 03.0, as the delayed calibration reports shows that both the errors are smaller than the maximum permissible errors (1%) of the flow meters, therefore, maximum permissible error (1%) is applied for the calculations of the volume of wastewater treated. For the baseline emission calculations, the monitored data will be corrected with 99% (100%-1%), while for the project emission calculations, the result will be corrected with 101%(100%+1%) for conservativeness.					

Data / Parameter:	$Q_{ww,i,y}$																			
Data unit:	m ³ /yr																			
Description:	Volume of wastewater treated in the year “y”																			
Measured /Calculated /Default:	Calculated																			
Source of data:	Flow meter records/operation logbook																			
Value(s) of monitored parameter:	6,861,146m ³ (this is the sum of daily records of two anaerobic digesters in both Plant 1 and 2, and ER calculations will be based on daily records. See the spreadsheet of ER calculation).																			
	Unit: m ³ /year	Plant 1 ($Q_{ww,1,y}$)	Plant 2 ($Q_{ww,2,y}$)																	
	2011	533,963	1,981,992																	
	2012	973,828	3,371,363																	
	Sub-total	1,507,791	5,353,355																	
Indicate what the data are used for (Baseline/ Project/ Leakage emission calculations)	Baseline and project emissions calculations.																			
Monitoring equipment (type, accuracy class, serial number, calibration frequency, date of last calibration, validity)	<table border="1"> <thead> <tr> <th></th> <th>Accuracy class</th> <th>Serial Number</th> <th>Calibration frequency</th> <th>Date of delayed calibration</th> <th>Validity</th> </tr> </thead> <tbody> <tr> <td>Plant 1</td> <td rowspan="2">1.0</td> <td>8500071800 0</td> <td rowspan="2">Two years</td> <td rowspan="2">14/08/2012</td> <td rowspan="2">13/08/2014</td> </tr> <tr> <td>Plant 2</td> <td>AD0701015</td> </tr> </tbody> </table>							Accuracy class	Serial Number	Calibration frequency	Date of delayed calibration	Validity	Plant 1	1.0	8500071800 0	Two years	14/08/2012	13/08/2014	Plant 2	AD0701015
	Accuracy class	Serial Number	Calibration frequency	Date of delayed calibration	Validity															
Plant 1	1.0	8500071800 0	Two years	14/08/2012	13/08/2014															
Plant 2		AD0701015																		
Measuring/ Reading/	Monitored continuously, read and recorded on daily based.																			

Recording frequency:	
Calculation method (if applicable):	$Q_{ww,i,y} = Q_{ww,1,y} + Q_{ww,2,y}$
QA/QC procedures applied:	<ul style="list-style-type: none"> ▪ Trained and qualified staff is responsible for recording data from the meter ▪ Meter will be calibrated periodically according to relevant national standards
Additional comment	As per Clean development mechanism validation and verification standard version 03.0, as the delayed calibration reports shows that both the errors are smaller than the maximum permissible errors (1%) of the flow meters, therefore, maximum permissible error (1%) is applied for the calculations of the volume of wastewater treated. For the baseline emission calculations, the monitored data will be corrected with 99% (100%-1%), while for the project emission calculations, the result will be corrected with 101%(100%+1%) for conservativeness.

Data / Parameter:	$COD_{ww,untreated,1,y}$
Data unit:	mg/l
Description:	Chemical oxygen demand of wastewater before the anaerobic treatment reactor/system with methane capture in plant 1 in the year “y”
Measured /Calculated /Default:	Measured
Source of data:	Laboratory test results
Value(s) of monitored parameter:	The average COD value before the existing anaerobic treatment is about 2,801mg/l. The baseline emissions and project emissions were calculated based on the corresponding monitored data (daily based).
Indicate what the data are used for (Baseline/ Project/ Leakage emission calculations)	Baseline and project emission calculations.
Monitoring equipment (type, accuracy class, serial number, calibration frequency, date of last calibration, validity)	By definition, chemical oxygen demand is “a measure of the oxygen equivalent of the organic matter content of a sample that is susceptible to oxidation by a strong chemical oxidant. Oxygen demand is determined by measuring the amount of oxidant consumed using an appropriate method that is in line with the national standards (e.g. titrimetric or photometric methods). Measured and recorded on a daily basis by monitoring personnel.
Measuring/ Reading/ Recording frequency:	Monitored, read and recorded on daily based.
Calculation method (if applicable):	Not applicable.
QA/QC procedures applied:	<ul style="list-style-type: none"> ▪ Trained and qualified staff is responsible for data measurement and recordings ▪ Sample taking and laboratory tests are conducted in compliance with national standard of <i>Methods of Monitoring and Analyzing of Water and Wastewater (Version 4) (GB11914)</i>
Additional comment	

Data / Parameter:	<i>COD_{ww,treated,1,y}</i>
Data unit:	mg/l
Description:	Chemical oxygen demand after the anaerobic treatment reactor/system with methane capture in plant 1 the year “y”
Measured /Calculated /Default:	Measured
Source of data:	Measured via lab test in compliance with national standard of <i>Methods of Monitoring and Analyzing of Water and Wastewater (Version 4) (GB11914)</i>
Value(s) of monitored parameter:	The average COD value before the existing anaerobic treatment is about 1,283mg/l. The baseline emissions and project emissions were calculated based on the corresponding monitored data (daily based).
Indicate what the data are used for (Baseline/ Project/ Leakage emission calculations)	Baseline and project emission calculations.
Monitoring equipment (type, accuracy class, serial number, calibration frequency, date of last calibration, validity)	By definition, chemical oxygen demand is “a measure of the oxygen equivalent of the organic matter content of a sample that is susceptible to oxidation by a strong chemical oxidant. Oxygen demand is determined by measuring the amount of oxidant consumed using an appropriate method that is in line with the national standards (e.g. titrimetric or photometric methods). Measured and recorded on a daily basis by monitoring personnel.
Measuring/ Reading/ Recording frequency:	Monitored, read and recorded on daily based.
Calculation method (if applicable):	Not applicable.
QA/QC procedures applied:	<ul style="list-style-type: none"> ▪ Trained and qualified staff is responsible for data measurement and recordings ▪ Sample taking and laboratory tests are conducted in compliance with national standard of <i>Methods of Monitoring and Analyzing of Water and Wastewater (Version 4) (GB11914)</i>
Additional comment	

Data / Parameter:	<i>COD_{ww,untreated,2,y}</i>
Data unit:	mg/l
Description:	Chemical oxygen demand of wastewater before the anaerobic treatment reactor/system with methane capture in plant 2 in the year “y”
Measured /Calculated /Default:	Measured
Source of data:	Laboratory test results
Value(s) of monitored parameter:	The average COD value before the existing anaerobic treatment is about 2,700mg/l. The baseline emissions and project emissions were calculated based on the corresponding monitored data (daily based).
Indicate what the data are used for (Baseline/ Project/ Leakage emission)	Baseline and project emission calculations.

calculations)	
Monitoring equipment (type, accuracy class, serial number, calibration frequency, date of last calibration, validity)	By definition, chemical oxygen demand is “a measure of the oxygen equivalent of the organic matter content of a sample that is susceptible to oxidation by a strong chemical oxidant. Oxygen demand is determined by measuring the amount of oxidant consumed using an appropriate method that is in line with the national standards (e.g. titrimetric or photometric methods). Measured and recorded on a daily basis by monitoring personnel.
Measuring/ Reading/ Recording frequency:	Monitored, read and recorded on daily based.
Calculation method (if applicable):	Not applicable.
QA/QC procedures applied:	<ul style="list-style-type: none"> ▪ Trained and qualified staff is responsible for data measurement and recordings ▪ Sample taking and laboratory tests are conducted in compliance with national standard of <i>Methods of Monitoring and Analyzing of Water and Wastewater (Version 4) (GB11914)</i>
Additional comment	

Data / Parameter:	<i>COD_{ww,treated,2,y}</i>
Data unit:	mg/l
Description:	Chemical oxygen demand after the anaerobic treatment reactor/system with methane capture in plant 2 the year “y”
Measured /Calculated /Default:	Measured
Source of data:	Measured via lab test in compliance with national standard of <i>Methods of Monitoring and Analyzing of Water and Wastewater (Version 4) (GB11914)</i>
Value(s) of monitored parameter:	The average COD value before the existing anaerobic treatment is about 1,282mg/l. The baseline emissions and project emissions were calculated based on the corresponding monitored data (daily based).
Indicate what the data are used for (Baseline/ Project/ Leakage emission calculations)	Baseline and project emission calculations.
Monitoring equipment (type, accuracy class, serial number, calibration frequency, date of last calibration, validity)	By definition, chemical oxygen demand is “a measure of the oxygen equivalent of the organic matter content of a sample that is susceptible to oxidation by a strong chemical oxidant. Oxygen demand is determined by measuring the amount of oxidant consumed using an appropriate method that is in line with the national standards (e.g. titrimetric or photometric methods). Measured and recorded on a daily basis by monitoring personnel.
Measuring/ Reading/ Recording frequency:	Monitored, read and recorded on daily based.
Calculation method (if applicable):	Not applicable.

QA/QC procedures applied:	<ul style="list-style-type: none"> Trained and qualified staff is responsible for data measurement and recordings Sample taking and laboratory tests are conducted in compliance with national standard of <i>Methods of Monitoring and Analyzing of Water and Wastewater (Version 4) (GB11914)</i>
Additional comment	

Data / Parameter:	$BG_{burnt,y}$												
Data unit:	Nm ³ /yr												
Description:	Amount of biogas combusted (fuelled and flared) in the year “y”												
Measured /Calculated /Default:	Measured by flow meters (normalized flow)												
Source of data:	Operation logbook												
Value(s) of monitored parameter:	<p>The amount of methane to be recovered 3,096,802 Nm³/yr in this monitoring period under normal conditions.</p> <table border="1"> <thead> <tr> <th>Unit: Nm³/year</th> <th>$BG_{burnt,y}$</th> </tr> </thead> <tbody> <tr> <td>2011</td> <td>1,230,040</td> </tr> <tr> <td>2012</td> <td>1,866,762</td> </tr> <tr> <td>Sub-total</td> <td>3,096,802</td> </tr> </tbody> </table>	Unit: Nm ³ /year	$BG_{burnt,y}$	2011	1,230,040	2012	1,866,762	Sub-total	3,096,802				
Unit: Nm ³ /year	$BG_{burnt,y}$												
2011	1,230,040												
2012	1,866,762												
Sub-total	3,096,802												
Indicate what the data are used for (Baseline/ Project/ Leakage emission calculations)	Baseline emission calculations.												
Monitoring equipment (type, accuracy class, serial number, calibration frequency, date of last calibration, validity)	<p>Normalized flow meter (for more details, please refer to Table 1 in Section C).</p> <table border="1"> <thead> <tr> <th>Type</th> <th>Accuracy class</th> <th>Serial Number</th> <th>Calibration frequency</th> <th>Date of delayed calibration</th> <th>Validity</th> </tr> </thead> <tbody> <tr> <td>TBQZ-250A12</td> <td>1.5</td> <td>11095105</td> <td>Two years</td> <td>15/05/2012</td> <td>14/05/2014</td> </tr> </tbody> </table>	Type	Accuracy class	Serial Number	Calibration frequency	Date of delayed calibration	Validity	TBQZ-250A12	1.5	11095105	Two years	15/05/2012	14/05/2014
Type	Accuracy class	Serial Number	Calibration frequency	Date of delayed calibration	Validity								
TBQZ-250A12	1.5	11095105	Two years	15/05/2012	14/05/2014								
Measuring/ Reading/ Recording frequency:	Measured continuously by a flow meter and recorded on a monthly basis by monitoring person.												
Calculation method (if applicable):	Not applicable.												
QA/QC procedures applied:	<ul style="list-style-type: none"> Trained and qualified staff is responsible for recording data from the flow meter Meter will be calibrated periodically according to relevant national standards 												
Additional comment	<p>For biogas combusted, as per Clean development mechanism validation and verification standard version 03.0, as the delayed calibration reports shows that the error is smaller than the maximum permissible errors (1.5%) of the flow meter, therefore, the maximum permissible error (1.5%) is applied for the calculations. For the baseline emission calculations, the monitored data will be corrected with 98.5% (100%-1.5%), while for the project emission calculations, the result will be corrected with 101.5%(100%+1.5%) for conservativeness. For biogas flared, as the temperature meter is not calibrated, the flaring efficiency is assumed to be 0% for conservativeness. That means whenever flare is on, all emission has been</p>												

	accounted as project emissions, and therefore the baseline emissions from biogas flared is 0.
--	---

Data / Parameter:	$W_{CH_4, fuelled, y}$												
Data unit:	% volume												
Description:	Methane content in the biogas combusted (fuelled) in year “y”												
Measured /Calculated /Default:	Measured with a gas analyser												
Source of data:	Operation logbook												
Value(s) of monitored parameter:	Fraction of methane in biogas is ranged from 60% to 95%. The emission reductions was calculated on the corresponding monitored data (hourly data together with $BG_{burnt, y}$).												
Indicate what the data are used for (Baseline/ Project/ Leakage emission calculations)	Baseline emission calculations.												
Monitoring equipment (type, accuracy class, serial number, calibration frequency, date of last calibration, validity)	Gas analyser (for more details, please refer to Table 1 in Section C). <table border="1" data-bbox="488 992 1437 1167"> <thead> <tr> <th>Type</th> <th>Accuracy class</th> <th>Serial Number</th> <th>Calibration frequency</th> <th>Date of delayed calibration</th> <th>Validity</th> </tr> </thead> <tbody> <tr> <td>LB-DQZ</td> <td>5.0</td> <td>741544</td> <td>One year</td> <td>17/08/2012</td> <td>16/08/2013</td> </tr> </tbody> </table>	Type	Accuracy class	Serial Number	Calibration frequency	Date of delayed calibration	Validity	LB-DQZ	5.0	741544	One year	17/08/2012	16/08/2013
Type	Accuracy class	Serial Number	Calibration frequency	Date of delayed calibration	Validity								
LB-DQZ	5.0	741544	One year	17/08/2012	16/08/2013								
Measuring/ Reading/ Recording frequency:	Measured continuously by gas analyzer and record on hourly basis.												
Calculation method (if applicable):	Not applicable												
QA/QC procedures applied:	<ul style="list-style-type: none"> ▪ Trained and qualified staff is responsible for carrying out the measurements ▪ Analyser will be calibrated periodically according to relevant national standard 												
Additional comment	As per Clean development mechanism validation and verification standard version 03.0, as the delayed calibration report shows that the error is smaller than the maximum permissible errors (5%) of the gas analyzer, therefore, the maximum permissible error (5%) is applied for the calculations. For the baseline emission calculations, the monitored data will be corrected with 95% (100%-5%), while for the project emission calculations, the result will be corrected with 105%(100%+5%) for conservativeness.												

Data / Parameter:	$FV_{RG, h, 1}$
Data unit:	Nm ³ /h
Description:	Volumetric flow rate of the residual gas in dry basis at normal conditions in hour <i>h</i> in plant 1
Measured	Measured by flow meters (normalized flow, otherwise temperature and pressure

/Calculated /Default:	will be monitored and corrected)												
Source of data:	Operation logbook												
Value(s) of monitored parameter:	Nil. Methane was not flared during this monitoring period.												
Indicate what the data are used for (Baseline/ Project/ Leakage emission calculations)	Baseline and project emissions.												
Monitoring equipment (type, accuracy class, serial number, calibration frequency, date of last calibration, validity)	<table border="1"> <thead> <tr> <th>Type</th> <th>Accuracy class</th> <th>Serial Number</th> <th>Calibration frequency</th> <th>Date of delayed calibration</th> <th>Validity</th> </tr> </thead> <tbody> <tr> <td>B3-11M175</td> <td>1.5</td> <td>B3-11M175</td> <td>Three years</td> <td>16/02/2012</td> <td>15/02/2015</td> </tr> </tbody> </table>	Type	Accuracy class	Serial Number	Calibration frequency	Date of delayed calibration	Validity	B3-11M175	1.5	B3-11M175	Three years	16/02/2012	15/02/2015
Type	Accuracy class	Serial Number	Calibration frequency	Date of delayed calibration	Validity								
B3-11M175	1.5	B3-11M175	Three years	16/02/2012	15/02/2015								
Measuring/ Reading/ Recording frequency:	Measured continuously and recorded by flow meter and record on hourly basis.												
Calculation method (if applicable):	Not applicable												
QA/QC procedures applied:	<ul style="list-style-type: none"> ▪ Trained and qualified staff is responsible for recording data from the flow meter ▪ Meter will be calibrated periodically according to relevant national standards 												
Additional comment	As per Clean development mechanism validation and verification standard version 03.0, as the delayed calibration report shows that the error is smaller than the maximum permissible errors (1.5%) of the flow meter, therefore, the maximum permissible error (1.5%) is applied for the calculations. For the baseline emission calculations, the monitored data will be corrected with 98.5% (100%-1.5%), while for the project emission calculations, the result will be corrected with 101.5%(100%+1.5%) for conservativeness.												

Data / Parameter:	$f_{V_{CH_4, RG, h, 1}}$
Data unit:	% volume
Description:	Volumetric fraction of methane in the residual gas on dry basis in hour h in plant 1
Measured /Calculated /Default:	Measured by Gas analyser
Source of data:	Operation logbook
Value(s) of monitored parameter:	Nil since no biogas was flared during this monitoring period.

Indicate what the data are used for (Baseline/ Project/ Leakage emission calculations)	Baseline and project emissions.												
Monitoring equipment (type, accuracy class, serial number, calibration frequency, date of last calibration, validity)	<table border="1"> <thead> <tr> <th>Type</th> <th>Accuracy class</th> <th>Serial Number</th> <th>Calibration frequency</th> <th>Date of delayed calibration</th> <th>Validity</th> </tr> </thead> <tbody> <tr> <td>LB-DQZ</td> <td>5.0</td> <td>776518</td> <td>One year</td> <td>24/10/2012</td> <td>23/10/2013</td> </tr> </tbody> </table>	Type	Accuracy class	Serial Number	Calibration frequency	Date of delayed calibration	Validity	LB-DQZ	5.0	776518	One year	24/10/2012	23/10/2013
Type	Accuracy class	Serial Number	Calibration frequency	Date of delayed calibration	Validity								
LB-DQZ	5.0	776518	One year	24/10/2012	23/10/2013								
Measuring/ Reading/ Recording frequency:	Measured continuously and recorded by gas analyzer and record on hourly basis.												
Calculation method (if applicable):	Not applicable.												
QA/QC procedures applied:	<ul style="list-style-type: none"> ▪ Trained and qualified staff is responsible for carrying out the measurements ▪ Analyser will be calibrated periodically according to relevant national standard 												
Additional comment	As per Clean development mechanism validation and verification standard version 03.0, as the delayed calibration report shows that the error is smaller than the maximum permissible errors (5%) of the gas analyzer, therefore, the maximum permissible error (5%) is applied for the calculations. For the baseline emission calculations, the monitored data will be corrected with 95% (100%-5%), while for the project emission calculations, the result will be corrected with 105%(100%+5%) for conservativeness.												

Data / Parameter:	$\eta_{\text{flare},1}$
Data unit:	%
Description:	Amount of minutes per hour where a flame has a higher temperature than 500°C, whenever biogas is sent to the flare in plant 1. The flare efficiency is assumed to be 50% during this period of time. Whenever the flame temperature is detected to be lower than 500°C, the same is recorded and the same is detected for less than 20 minutes in an hour (whenever biogas is sent to flare), flare efficiency is assumed to be 0%. Otherwise flare efficiency is assumed to be 50%.
Measured /Calculated /Default:	Default
Source of data:	Operation logbook
Value(s) of monitored parameter:	0%.

Indicate what the data are used for (Baseline/ Project/ Leakage emission calculations)	Baseline and project emissions.										
Monitoring equipment (type, accuracy class, serial number, calibration frequency, date of last calibration, validity)	<p>The qualified staff is responsible for detecting the flame and recorded on the operation logbook. An online temperature gauge is used for measuring the temperature of the flame.</p> <table border="1"> <thead> <tr> <th>Type</th> <th>Accuracy class</th> <th>Serial Number</th> <th>Date of delayed calibration</th> <th>Validity</th> </tr> </thead> <tbody> <tr> <td>-</td> <td>3%</td> <td>-</td> <td>Not calibrated</td> <td>Not calibrated</td> </tr> </tbody> </table>	Type	Accuracy class	Serial Number	Date of delayed calibration	Validity	-	3%	-	Not calibrated	Not calibrated
Type	Accuracy class	Serial Number	Date of delayed calibration	Validity							
-	3%	-	Not calibrated	Not calibrated							
Measuring/ Reading/ Recording frequency:	Measured continuously and record on hourly basis.										
Calculation method (if applicable):	Not applicable.										
QA/QC procedures applied:	<ul style="list-style-type: none"> Trained and qualified staff is responsible for carrying out the measurements 										
Additional comment	As the temperature meter is not calibrated, the flaring efficiency is assumed to be 0% for conservativeness. That means whenever flare is on, all emission has been accounted as project emissions, and therefore the baseline emissions from biogas flared is 0.										

Data / Parameter:	$FV_{RG,h,2}$								
Data unit:	Nm ³ /h								
Description:	Volumetric flow rate of the residual gas in dry basis at normal conditions in hour <i>h</i> in plant 2								
Measured /Calculated /Default:	Measured by flow meters (normalized flow, otherwise temperature and pressure will be monitored and corrected)								
Source of data:	Operation logbook								
Value(s) of monitored parameter:	<p>32,261Nm³ during this monitoring period (corrected with max. permissible error).</p> <table border="1"> <thead> <tr> <th>Unit: Nm³/year</th> <th>$FV_{RG,h,2}$</th> </tr> </thead> <tbody> <tr> <td>2011</td> <td>4,116</td> </tr> <tr> <td>2012</td> <td>28,145</td> </tr> <tr> <td>Sub-total</td> <td>32,261</td> </tr> </tbody> </table>	Unit: Nm ³ /year	$FV_{RG,h,2}$	2011	4,116	2012	28,145	Sub-total	32,261
Unit: Nm ³ /year	$FV_{RG,h,2}$								
2011	4,116								
2012	28,145								
Sub-total	32,261								
Indicate what the data are used for (Baseline/ Project/ Leakage emission calculations)	Baseline and project emissions.								

Monitoring equipment (type, accuracy class, serial number, calibration frequency, date of last calibration, validity)	Type	Accuracy class	Serial Number	Calibration frequency	Date of delayed calibration	Validity
	TBQZ-200A12	1.5	11095090	Two years	16/02/2012	15/02/2014
Measuring/ Reading/ Recording frequency:	Measured continuously by flow meter and record on hourly basis.					
Calculation method (if applicable):	Not applicable.					
QA/QC procedures applied:	<ul style="list-style-type: none"> ▪ Trained and qualified staff is responsible for recording data from the flow meter ▪ Meter will be calibrated periodically according to relevant national standards 					
Additional comment	As per Clean development mechanism validation and verification standard version 03.0, as the delayed calibration report shows that the error is smaller than the maximum permissible errors (1.5%) of the flow meter, therefore, the maximum permissible error (1.5%) is applied for the calculations. For the baseline emission calculations, the monitored data will be corrected with 98.5% (100%-1.5%), while for the project emission calculations, the result will be corrected with 101.5%(100%+1.5%) for conservativeness.					

Data / Parameter:	$f_{VCH_4, RG, h, 2}$					
Data unit:	% volume					
Description:	Volumetric fraction of methane in the residual gas on dry basis in hour h in plant 2					
Measured /Calculated /Default:	Measured by gas analyser.					
Source of data:	Operation logbook					
Value(s) of monitored parameter:	60%-76%.					
Indicate what the data are used for (Baseline/ Project/ Leakage emission calculations)	Baseline and project emissions.					
Monitoring equipment (type, accuracy class, serial number, calibration frequency, date of last calibration, validity)	Type	Accuracy class	Serial Number	Calibration frequency	Date of delayed calibration	Validity
	LB-DQZ	5.0	741543	One year	17/082012	16/08/2013
Measuring/ Reading/	Measured continuously by gas analyzer and record on hourly basis.					

Recording frequency:	
Calculation method (if applicable):	Not applicable.
QA/QC procedures applied:	<ul style="list-style-type: none"> ▪ Trained and qualified staff is responsible for carrying out the measurements ▪ Analyser will be calibrated periodically according to relevant national standard
Additional comment	As per Clean development mechanism validation and verification standard version 03.0, as the delayed calibration report shows that the error is smaller than the maximum permissible errors (5%) of the gas analyzer, therefore, the maximum permissible error (5%) is applied for the calculations. For the baseline emission calculations, the monitored data will be corrected with 95% (100%-5%), while for the project emission calculations, the result will be corrected with 105%(100%+5%) for conservativeness.

Data / Parameter:	$\eta_{\text{flare},2}$										
Data unit:	%										
Description:	<p>Amount of minutes per hour where a flame has a higher temperature than 500°C, whenever biogas is sent to the flare in plant 1. The flare efficiency is assumed to be 50% during this period of time. Whenever the flame temperature is detected to be lower than 500°C, the same is recorded and the same is detected for less than 20 minutes in an hour (whenever biogas is sent to flare), flare efficiency is assumed to be 0%.</p> <p>Otherwise flare efficiency is assumed to be 50%.</p>										
Measured /Calculated /Default:	Default										
Source of data:	Operation logbook										
Value(s) of monitored parameter:	0%.										
Indicate what the data are used for (Baseline/ Project/ Leakage emission calculations)	Baseline and project emissions.										
Monitoring equipment (type, accuracy class, serial number, calibration frequency, date of last calibration, validity)	<p>The qualified staff is responsible for detecting the flame and recorded on the operation logbook. An online temperature gauge is used for measuring the temperature of the flame.</p> <table border="1" style="width: 100%; border-collapse: collapse;"> <thead> <tr> <th>Type</th> <th>Accuracy class</th> <th>Serial Number</th> <th>Date of delayed calibration</th> <th>Validity</th> </tr> </thead> <tbody> <tr> <td>-</td> <td>3%</td> <td>-</td> <td>Not calibrated</td> <td>Not calibrated</td> </tr> </tbody> </table>	Type	Accuracy class	Serial Number	Date of delayed calibration	Validity	-	3%	-	Not calibrated	Not calibrated
Type	Accuracy class	Serial Number	Date of delayed calibration	Validity							
-	3%	-	Not calibrated	Not calibrated							
Measuring/ Reading/ Recording frequency:	Measured continuously and record on hourly basis when flare is on.										
Calculation method	Not applicable.										

(if applicable):	
QA/QC procedures applied:	<ul style="list-style-type: none"> ▪ Trained and qualified staff is responsible for carrying out the measurements
Additional comment	As the temperature meter is not calibrated, the flaring efficiency is assumed to be 0% for conservativeness. That means whenever flare is on, all emission has been accounted as project emissions, and therefore the baseline emissions from biogas flared is 0.

Data / Parameter:	<i>Final disposal of sludge</i>
Data unit:	-
Description:	For the proposed project, the final sludge is being transported outside of the project site to a controlled landfill.
Measured /Calculated /Default:	Observed.
Source of data:	Observed and sludge transportation/treatment contract.
Value(s) of monitored parameter:	Not applicable.
Indicate what the data are used for (Baseline/ Project/ Leakage emission calculations)	None.
Monitoring equipment (type, accuracy class, serial number, calibration frequency, date of last calibration, validity)	Not applicable.
Measuring/ Reading/ Recording frequency:	Not applicable.
Calculation method (if applicable):	Not applicable.
QA/QC procedures applied:	Trained and qualified staff is responsible for carrying out the measurements
Additional comment	

2)Electricity generation component:

Data / Parameter:	EG_{BLy}												
Data unit:	<i>MWh</i>												
Description:	Quantity of net electricity displaced as a result of the implementation of the project activity in year <i>y</i>												
Measured /Calculated /Default:	Measured by electricity meter.												
Source of data:	Operation logbooks.												
Value(s) of monitored parameter:	7,091.8MWh (this is the sum of daily records, ER calculations will be based on daily records, see the spreadsheet of ER calculation). <table border="1" style="margin-left: auto; margin-right: auto;"> <thead> <tr> <th>Unit: MWh</th> <th></th> </tr> </thead> <tbody> <tr> <td>2011</td> <td>2,888.6</td> </tr> <tr> <td>2012</td> <td>4,203.2</td> </tr> <tr> <td>Sub-total</td> <td>7,091.8</td> </tr> </tbody> </table>	Unit: MWh		2011	2,888.6	2012	4,203.2	Sub-total	7,091.8				
Unit: MWh													
2011	2,888.6												
2012	4,203.2												
Sub-total	7,091.8												
Indicate what the data are used for (Baseline/ Project/ Leakage emission calculations)	Baseline emissions.												
Monitoring equipment (type, accuracy class, serial number, calibration frequency, date of last calibration, validity)	Measured continuously by a double-way kilowatt meters and recorded on a daily basis by monitoring personnel. <table border="1" style="margin-left: auto; margin-right: auto;"> <thead> <tr> <th>Type</th> <th>Accuracy class</th> <th>Serial Number</th> <th>Calibration frequency</th> <th>Date of last calibration</th> <th>Validity</th> </tr> </thead> <tbody> <tr> <td>DSSD19</td> <td>0.5S</td> <td>Kkk2090204</td> <td>Five years</td> <td>14/12/2012</td> <td>13/12/2017</td> </tr> </tbody> </table> <p>The calibration frequency is five years that is line with the national standard JJG596-1999⁴.</p>	Type	Accuracy class	Serial Number	Calibration frequency	Date of last calibration	Validity	DSSD19	0.5S	Kkk2090204	Five years	14/12/2012	13/12/2017
Type	Accuracy class	Serial Number	Calibration frequency	Date of last calibration	Validity								
DSSD19	0.5S	Kkk2090204	Five years	14/12/2012	13/12/2017								
Measuring/ Reading/ Recording frequency:	Measuring continuously, record on monthly basis.												
Calculation method (if applicable):	The electricity displaced equals to the readings difference of the electricity meter times meter rate.												
QA/QC procedures applied:	<ul style="list-style-type: none"> ▪ Trained and qualified staff is responsible for recording electricity supplied and consumed data from the kilowatt meters; ▪ Meters will be calibrated periodically according to relevant national standards. 												
Additional comment	Only the net electricity generation shall be taken into account in ER calculation. As per Clean development mechanism validation and verification standard version 03.0, as the delayed calibration report shows that the error is smaller than the maximum permissible errors (0.5%) of the electricity meter, therefore, the maximum permissible error (0.5%) is applied for the calculations. For the												

⁴ <http://www.docin.com/p-317149000.html>

emission calculations, the monitored data has been corrected with 99.5% (100%-0.5%) for conservativeness.

D.3 Implementation of sampling plan

>>

The analysis of COD content before and after the anaerobic digesters will be sampled and measured through lab test based on GB11914 (Monitoring and Analyzing of Water and Wastewater). Therefore, the data of COD removed will be the difference of these two values. Since there are two anaerobic digesters involved in the project activity, the test will be done separately for the COD content after each reactor. Based on Figure 3 (section C of this MR), the wastewater from sample 1 and 3 will be the basis for testing the COD content of the wastewater before digesters; Sample 2 and 4 will be used for testing COD content of wastewater after anaerobic digesters. The qualified and trained staff is collecting the samples of the wastewater before and after each reactor (both Plant 1 and plant 2) once every day, and after the lab test, the monitored data will be recorded as per the monitoring manual.

SECTION E. Emission reductions calculation

The calibrations of all the monitoring meters are delayed. As per VVS 3.0, the conservative approach is applied to the monitoring data of each meter. For the details of the calculations, please refer to the following text of this section.

E.1. Baseline emissions calculation

>>

1. Methane Component:

1.1 Calculation of $BE_{methane,y}$

The baseline scenario for the methane avoidance component of the Project is the existing anaerobic wastewater treatment system without methane recovery and combustion. As per the registered PDD, $BE_{methane,y}$ is calculated as following:

$$BE_{methane,y} = BE_{ww,treatment,y} = \sum_i Q_{ww,i,y} * COD_{removed,i,y} * MCF_{ww,treatment,BL,i} * B_{o,ww} * UF_{BL} * GWP_{CH4}$$

Where:

Where:

$BE_{methane,y}$ Baseline emissions due to methane avoidance in year y (tCO₂e)

$BE_{ww,treatment,y}$ Baseline emissions of the wastewater treatment systems affected by the project activity in year y (tCO₂e)

$Q_{ww,i,y}$ Volume of wastewater treated in baseline wastewater treatment system *i* in year y (m³)

$COD_{removed,i,y}$ Chemical oxygen demand removed by baseline treatment system *i* in year y (tonnes/m³), measured as the difference between inflow COD and the outflow COD in system *i*

$MCF_{ww,treatment,BL,i}$ Methane correction factor for baseline wastewater treatment systems *i* (MCF value for Anaerobic reactor without methane recovery is 0.8 as per table III.H.1)

$B_{o,ww}$ Methane producing capacity of the wastewater (IPCC value of 0.25 kg CH₄/kg COD)

UF_{BL} Model correction factor to account for model uncertainties (0.89)

GWP_{CH4} Global Warming Potential for methane (value of 21)

The parameter values and calculation results for $BE_{methane,y}$ in year 2011 and 2012 are listed below:

BE_{methane,2011} (corrected with max. permissible error*)

Parameter	Value	Unit	Data source
$Q_{ww,i,2011}$	2,490,795	m ³	Operation records
$COD_{removed,i,y}$	Daily based	mg/l	Operation records
$MCF_{ww,treatment,BL,i}$	0.8	n/a	Default value, registered PDD
$Bo_{,ww}$	0.25	n/a	Default value, registered PDD
UF_{BL}	0.89	n/a	Default value, registered PDD
GWP_{CH4}	21	n/a	Default value, registered PDD
$BE_{methane,2011}$	12,544	tCO ₂ e	Calculated

BE_{methane,2012} (corrected with max. permissible error*)

Parameter	Value	Unit	Data source
$Q_{ww,i,2012}$	4,301,739	m ³	Operation records
$COD_{removed,i,y}$	Daily based	mg/l	Operation records
$MCF_{ww,treatment,BL,i}$	0.8	n/a	Default value, PDD
$Bo_{,ww}$	0.25	n/a	Default value, PDD
UF_{BL}	0.89	n/a	Default value, PDD
GWP_{CH4}	21	n/a	Default value, PDD
$BE_{methane,2012}$	24,290	tCO ₂ e	Calculated

* Note: The calibrations for wastewater flow meters in plant 1 and 2 (measuring $Q_{ww,1,y}$ and $Q_{ww,2,y}$, respectively) have been delayed in this monitoring period, and the calibrations have been implemented on Aug. 14th. 2012, and it is slightly before the end of this monitoring period (Aug.31st 2012).The table below lists the errors identified in the delayed calibration reports and maximum permissible error specified by the manufacturers of the meters and it shows the maximum permissible errors are larger. As per Clean development mechanism validation and verification standard version 03.0, the maximum permissible error 1% is adopted and a discount of 99% (100% minus 1%) is applied for $BE_{methane}$ among this entire monitoring period for conservativeness and simplicity.

	Plant 1	Plant 2
Serial number	85000718000	AD0701015
Error in delayed calibration reports	-0.97%	+0.65%
Max. permissible error specified by the manufacturer	± 1%	± 1%

1.2 Calculation of MD_{methane,y}

$$MD_{methane,y} = BG_{burnt,y} * W_{CH4} * D_{CH4} * FE * GWP_{CH4}$$

Where:

- $BG_{burnt,y}$ Biogas flared and combusted in year y (m³)
 $w_{CH4,y}$ Methane content in the biogas in the year y (volume fraction)
 D_{CH4} Density of methane at the temperature and pressure of the biogas in the year y (tonnes/m³)
 FE Flare efficiency in year y (fraction)
 GWP_{CH4} Global Warming Potential for methane (value of 21)

***MD*_{methane,2011} (corrected with max. permissible error*)**

Parameter	Value	Unit	Data source
<i>BG</i> _{burnt,2011} (Biogas flared and combusted)	1,230,040	Nm ³	Calculated as per operation records
<i>W</i> _{CH4}	60-95%		Monitored data, log book
<i>D</i> _{CH4}	0.000716	t/Nm ³	IPCC default value
<i>FE</i>	100%,0%		As per the default value referring to paragraph 33, AMS.III.H version 15, FE will be 100% if the biogas is combusted in the gas engine. While for the open flaring system, since the temperature meter of the flam is not calibrated, a flaring efficiency of 0% is applied for conservativeness ⁵ .
<i>GWP</i> _{CH4}	21	tCO ₂ e	IPCC default value
<i>MD</i> _{methane,2011}	17,291	tCO ₂ e	Calculated

***MD*_{methane,2012} (corrected with max. permissible error*)**

Parameter	Value	Unit	Data source
<i>BG</i> _{burnt,2012}	1,866,762	Nm ³	Calculated as per operation records
<i>W</i> _{CH4}	60-95%		Monitored data, log book
<i>D</i> _{CH4}	0.000716	t/Nm ³	IPCC default value
<i>FE</i>	100%, 0%		As per the default value referring to paragraph 33, AMS.III.H version 15, FE will be 100% if the biogas is combusted in the gas engine. While for the open flaring system, since the temperature meter of the flam is not calibrated, a flaring efficiency of 0% is applied for conservativeness
<i>GWP</i> _{CH4}	21	tCO ₂ e	IPCC default value
<i>MD</i> _{methane,2012}	26,861	tCO ₂ e	Calculated

*Note: For biogas combusted in the engine, the calibrations for the flow meter and the meter measuring *W*_{CH4,y} have been delayed during this monitoring period. And the calibrations have been implemented on May 15th, 2012 and Aug. 17th, 2012 respectively, and those are slightly before the end of this monitoring period (Aug. 31st, 2012). The table below lists the errors identified in the delayed calibration reports and maximum permissible errors specified by the manufacturers of the meters and it shows the maximum permissible errors are larger. As per Clean development mechanism validation and verification standard version 03.0, and for conservativeness and simplicity, the maximum permissible error 1.5% and 5% are adopted for this entire monitoring period and discounts of 98.5% (100% minus 1.5%) and 95% (100%-5%) are applied for the calculation of baseline emissions from biogas combusted.

⁵ Whenever the flare starts working, the working time is logged as a part of the operation records and the flame is detected. Notes will be made on the logbooks if the temperature of flame is lower than 500°C. As per the operation records for this monitored period, the temperature is never below 500°C. However, since the temperature meter is never calibrated, the flaring efficiency is assumed to 0% for conservativeness.

	<i>BG_{burnt}</i>	<i>WCH_{4,fuelled}</i>
Serial number	11095105	741544
Error in delayed calibration reports	0.78%	2.0%
Max. permissible error defined by the manufacturer	1.5%	5%

For biogas flared, the calibrations for biogas flow meters (measuring $FV_{RG,h,1}$ and $FV_{RG,h,2}$ respectively) have been delayed and both the calibrations have been implemented on Feb. 16th, 2012, while the end of this monitoring period is on Aug. 31st, 2012. The table below lists the errors identified in the delayed calibration reports and maximum permissible error specified by the manufacturers of the meters and it shows the maximum permissible error is larger. As per Clean development mechanism validation and verification standard version 03.0, and in order to be conservative and simple, the maximum permissible error 1.5% is adopted for this entire monitoring period and a multiplier of 98.5% (100% minus 1.5%) applied for the baseline emissions from biogas flared.

	Plant 1 ($FV_{RG,h,1}$)	Plant 2 ($FV_{RG,h,2}$)
Serial number	B3-11M175	11095090
Error in delayed calibration reports	0.46%	0.4%
Max. permissible error specified by the manufacturers	1.5%	1.5%

Also, for biogas flared, the calibrations for volumetric fraction meters (measuring $fV_{CH4,RG,h,1}$ and $fV_{CH4,RG,h,2}$) have also been delayed and the calibrations have been implemented on Aug. 17th 2012 and Oct. 24th, 2012 respectively, while this monitoring period ends on Aug. 31st, 2012. The table below lists the errors identified in the delayed calibration reports and maximum permissible error specified by the manufacturers of the meters and it shows the maximum permissible error is larger. As per Clean development mechanism validation and verification standard version 03.0, and in order to be conservative and simple, the maximum permissible error 5% is adopted during this entire monitoring period and a multiplier of 95% (100% minus 5%) applied for the baseline emissions from biogas flared. However, as the temperature meter is not calibrated, the flaring efficiency is assumed to be 0% for conservativeness. That means whenever flare is on, all emission has been accounted as project emissions, and therefore the baseline emissions from biogas flared is 0.

	Plant 1	Plant 2
Serial number	776518	741543
Error in delayed calibration reports	-2.4%	2.6%
Max. permissible error defined by the manufacture	5%	5%

2. Electricity Component:

The baseline scenario for the electricity component of the Project is the electricity would be supplied from the grid. As per the registered PDD, BE_y is calculated as below:

$$BE_y = EG_{BL,y} * EF_{CO2,y}$$

Where:

$EG_{BL,y}$ Quantity of net electricity displaced as a result of the implementation of the CDM project activity in year y (MWh)

$EF_{CO2,y}$ Emission factor (tCO₂/MWh)

The parameter values and calculation results for BE_y in year 2011 and 2012 are listed below:

BE₂₀₁₁ (corrected with max. permissible error*)

Parameter	Value	Unit	Data source
<i>EG_{BL,2011}</i>	2,888.6	MWh	Monitored data
<i>EF_{CO2,2011}</i>	0.7690	tCO ₂ /MWh	Justified in PDD
<i>BE₂₀₁₁</i>	2,221	tCO ₂ e	Calculated as monitored data

BE₂₀₁₂ (corrected with max. permissible error*)

Parameter	Value	Unit	Data source
<i>EG_{BL,2012}</i>	4,023.2	MWh	Monitored data
<i>EF_{CO2,2012}</i>	0.7690	tCO ₂ /MWh	Justified in PDD
<i>BE₂₀₁₂</i>	3,232	tCO ₂ e	Calculated as monitored data

*Note: The calibration for the electricity meter (measuring *EG_{BL,y}*) has been delayed, and the calibration has been implemented after this monitoring period. The table below lists the errors identified in the delayed calibration report and maximum permissible error specified by the manufacturers of the meter and it shows the maximum permissible error is same to the one in the delayed calibration report. As per Clean development mechanism validation and verification standard version 03.0, the maximum permissible error 0.5% is adopted for this entire monitoring period and a discount of 99.5% (100% minus 0.5%) is applied for BE_y.

	<i>EG_{BL}</i>
Serial number	KKK2090204
Error in delayed calibration report	0.5%
Max. permissible error defined by the manufacturer	0.5%

E.2. Project emissions calculation

>>

1. Methane Component:

As per registered PDD, the project activity emissions due to methane avoidance are calculated with following formula :

$$PE_{methane,y} = PE_{fugitive,y} + PE_{flaring,y} \quad \text{Equation (2.1)}$$

Where:

<i>PE_{methane,y}</i>	Project activity emissions due to methane avoidance in the year “y” (tCO ₂ e)
<i>PE_{fugitive,y}</i>	Methane emissions from biogas release in capture systems in year y.
<i>PE_{flaring,y}</i>	Methane emissions due to incomplete flaring in year y as per the “Tool to determine project emissions from flaring gases containing methane”(tCOe)

a) for *PE_{fugitive,y}*,

$$PE_{fugitive,y} = PE_{fugitive,ww,y} = (1 - CFE_{ww}) \cdot MEP_{ww,treatment,y} \cdot GWP_{CH4}$$

Where:

<i>PE_{fugitive,ww,y}</i>	Fugitive emissions through capture inefficiencies in the anaerobic wastewater treatment in year “y” (tCO ₂ e);
<i>CFE_{ww}</i>	Capture efficiency of the biogas recovery equipment in the wastewater treatment systems (a default value of 0.9 shall be used)
<i>GWP_{CH4}</i>	Global Warming Potential for methane (value of 21 is used)
<i>MEP_{ww,treatment,y}</i>	Methane emission potential of wastewater treatment systems equipped with biogas recovery system in year y (tonnes) which is calculated according to the equation below:

$$MEP_{ww,treatment,y} = Q_{ww,y} * B_{o,ww} * UF_{PJ} * \sum_k COD_{removed,PJ,k,y} \cdot MCF_{ww,treatment,PJ,k} \quad (2.2.2)$$

Where:

- $Q_{ww,y}$ Volume of wastewater treated in the year y (m³)
 $B_{o,ww}$ Methane producing capacity of the wastewater (IPCC default value for domestic wastewater of 0.25kg CH₄/kg COD)
 $COD_{removed,PJ,k,y}$ The chemical oxygen demand removed by the treatment system k of the project activity equipped with biogas recovery in the year y (tonnes/m³)
 $MCF_{ww,treatment,PJ,k,y}$ Methane correction factor for the project wastewater treatment system k equipped with biogas recovery equipment (MCF value for Anaerobic reactor without methane recovery is 0.8 as per table III.H.)
 UF_{PJ} Model correction factor to account for model uncertainties (1.12)

The parameter values and calculation results for $PE_{fugitive,y}$ in year 2011 and 2012 are listed below:

PE_{fugitive,2011} (corrected with max. permissible error*)

Parameter	Value	Unit	Data source
CFE_{ww}	0.9		Default value, PDD
$Q_{ww,i,2011}$	2,541,115	m ³	Monitored data, logbook
$COD_{removed,i,y}$	Daily based	tonnes/m ³	
$MCF_{ww,treatment,BL,i}$	0.8		Operation records
$B_{o,ww}$	0.25	CH ₄ /kg	Default value, PDD
UF_{PJ}	1.12		Default value, PDD
GWP_{CH4}	21		IPCC default value, PDD
$PE_{fugitive,2011}$	1,610.5	tCO ₂ e	Calculated

PE_{fugitive,2012} (corrected with max. permissible error*)

Parameter	Value	Unit	Data source
CFE_{ww}	0.9	m ³	Default value, PDD
$Q_{ww,i,2012}$	4,388,643	tonnes/m ³	Monitored data, logbook
$COD_{removed,i,y}$	Daily based		
$MCF_{ww,treatment,BL,i}$	0.8	CH ₄ /kg	Operation records
$B_{o,ww}$	0.25		Default value, PDD
UF_{PJ}	1.12		Default value, PDD
GWP_{CH4}	21	tCO ₂ e	IPCC default value, PDD
$PE_{fugitive,2012}$	3,118.5	m ³	Calculated

*Note: The calibrations for wastewater flow meters in plant 1 and 2 (measuring $Q_{ww,1,y}$ and $Q_{ww,2,y}$ respectively) have been delayed and both the calibrations have been implemented on Aug. 14th, 2012, and that is slight before the end of this monitoring period (Aug. 31st, 2012). The table below lists the errors identified in the delayed calibration reports and maximum permissible error specified by the manufacturers of the meters and it shows the maximum permissible error is larger. As per Clean development mechanism validation and verification standard version 03.0, and for simplicity and conservativeness, the maximum permissible error 1% is adopted and a multiplier of 101% (100% plus 1%) applied (for this entire monitoring period) for $PE_{fugitive,y}$ calculation.

	Plant 1	Plant 2
Serial number	85000718000	AD0701015
Error in delayed calibration reports	-0.97%	+0.65%
Max. permissible error specified by the manufacturer	± 1%	± 1%

b) For $PE_{flaring,y}$

$$PE_{flaring,y} = \sum_{i=1}^{8760} TM_{RG,h} * (1 - \eta_{flare,h}) * \frac{GWP_{CH_4}}{1000}$$

Where:

$PE_{flare,y}$: Project emissions from flaring of the residual gas stream in a year y ; tCO₂e
 $TM_{RG,h}$: Mass flow rate of methane in the residual gas in the hour h ; kg/h
 η_{flare} : Flare efficiency in hour h ;

The mass flow rate of methane in the residual gas is calculated as follows:

$$TM_{RG,h} = FV_{RG,h} * fv_{CH_4, RG,h} * \rho_{CH_4,n}$$

Where:

$TM_{RG,h}$: Mass flow rate of methane in the residual gas in the hour h ; kg/h
 $FV_{RG,h}$: Volumetric flow rate of the residual gas in dry basis at normal conditions in hour h ; Nm³/h
 $fv_{CH_4, RG,h}$: Volumetric fraction of methane in the residual gas on dry basis in hour h ;
 $\rho_{CH_4,n}$: Density of methane at normal conditions (0.716 kg/Nm³ or 0.000716 t/Nm³)

The parameter values and calculation results for $PE_{flaring,y}$ in year 2011 and 2012 are listed below:

$PE_{flaring,y}$ in 2011 (corrected with max. permissible error*)

Parameter	Value	Unit	Comments/source
$PE_{flaring,2011}$	43.7	tCO ₂ e	See detailed calculation in ER spread sheet.

$PE_{flaring,y}$ in 2012 (corrected with max. permissible error*)

Parameter	Value	Unit	Comments/source
$PE_{flaring,2012}$	266.7	tCO ₂ e	See detailed calculation in ER spread sheet

*Note: The calibrations for biogas flow meters (measuring $FV_{RG,h,1}$ and $FV_{RG,h,2}$ respectively) have been delayed and both of the calibrations have been implemented on Feb. 16th, 2012, while this monitoring period ends up on Aug. 31st, 2012. The table below lists the errors identified in the delayed calibration reports and maximum permissible error specified by the manufacturers of the meters and it shows the maximum permissible error is larger. As per Clean development mechanism validation and verification standard version 03.0, for conservativeness and simplicity, the maximum permissible error 1.5% is adopted for this entire monitoring period and a multiplier of 101.5% (100% plus 1.5%) applied for $PE_{flare,y}$. Furthermore, as the temperature meter is not calibrated, the flaring efficiency is assumed to be 0% for conservativeness. That means whenever flare is on, all emission has been accounted as project emissions.

	Plant 1	Plant 2
--	---------	---------

Serial number	B3-11M175	11095090
Error in delayed calibration reports	0.46%	0.4%
Max. permissible error specified by the manufacturers	1.5%	1.5%

The calibrations for volumetric fraction meters (measuring $fv_{CH_4,RG,h,1}$ and $fv_{CH_4,RG,h,2}$) have also been and the calibrations have been implemented on Aug. 17th, 2012 and Oct. 24th, 2012 respectively, while this monitoring period ends up on Aug. 31st, 2012. The table below lists the errors identified in the delayed calibration reports and maximum permissible error specified by the manufacturers of the meters and it shows the maximum permissible error is larger. As per Clean development mechanism validation and verification standard version 03.0, for conservativeness and simplicity, the maximum permissible error 5% is adopted during this entire monitoring period and a multiplier of 105% (100% plus 5%) applied for $PE_{flare,y}$. Furthermore, as the temperature meter is not calibrated, the flaring efficiency is assumed to be 0% for conservativeness. That means whenever flare is on, all emission has been accounted as project emissions.

	Plant 1 ($fv_{CH_4,RG,h,1}$)	Plant 2 ($fv_{CH_4,RG,h,2}$)
Serial number	776518	741543
Error in delayed calibration reports	-2.4%	2.6%
Max. permissible error defined by the manufacture	5%	5%

Therefore, $PE_{methane,y}$ for year 2011 and 2012 is:

$PE_{fugitive,2011}$	$PE_{flaring,2011}$	$PE_{methane,2011}$
1,610.5tCO ₂ e	43.7tCO ₂ e	1,655tCO ₂ e
$PE_{fugitive,2012}$	$PE_{flaring,2012}$	$PE_{methane,2012}$
3,118.5tCO ₂ e	266.7tCO ₂ e	3,386tCO ₂ e

2. Electricity Component:

As per registered PDD,

$$PE_y = 0$$

E.3. Leakage calculation

1. Methane Component:

The proposed project activity does not involve upgrading and bottling of biogas either. Therefore, there is no leakage.

2. Electricity Component:

There is neither energy generating equipment transferred from another activity nor existing equipment transferred to another activity, therefore, there is no leakage.

E.4. Emission reductions calculation / table

1. Methane Component:

As per registered PDD, the $ER_{methane,y}$ is decided with following formula:

$$ER_{methane,y,expost} = \min((BE_{methane,y,expost} - PE_{methane,y,expost} - LE_{methane,y,expost}), (MD_{methane,y} - PE_{power,y} - PE_{biomass,y} - LE_{methane,y,expost}))$$

The calculation and comparison results are summarized as below:

a) $BE_{methane,y,expost} - PE_{methane,y,expost} - LE_{methane,y,expost}$

Value of 2011

Parameter	Value	Unit
$BE_{methane,2011,expost}$	12,544	tCO ₂ e
$PE_{methane,2011,expost}$	1,655	tCO ₂ e
$LE_{methane,2011,expost}$	0	tCO ₂ e
$BE_{methane,2011,expost} - PE_{methane,2011,expost} - LE_{methane,2011,expost}$	10,889	tCO ₂ e

Value of 2012

Parameter	Value	Unit
$BE_{methane,2012,expost}$	24,290	tCO ₂ e
$PE_{methane,2012,expost}$	3,386	tCO ₂ e
$LE_{methane,2012,expost}$	0	tCO ₂ e
$BE_{methane,2012,expost} - PE_{methane,2012,expost} - LE_{methane,2012,expost}$	20,904	tCO ₂ e

b) $MD_{methane,y} - PE_{power,y} - PE_{biomass,y} - LE_{methane,y,expost}$

Value of 2011

Parameter	Value	Unit
$MD_{methane,2011}$	17,291	tCO ₂ e
$PE_{power,2011}$	0	tCO ₂ e
$PE_{biomass,2011}$	0	tCO ₂ e
$LE_{methane,2011,expost}$	0	tCO ₂ e
$MD_{methane,2011} - PE_{power,2011} - PE_{biomass,2011} - LE_{methane,2011,expost}$	17,291	tCO ₂ e

Value of 2012

Parameter	Value	Unit
$MD_{methane,2012}$	26,861	tCO ₂ e
$PE_{power,2012}$	0	tCO ₂ e
$PE_{biomass,2012}$	0	tCO ₂ e
$LE_{methane,2012,expost}$	0	tCO ₂ e
$MD_{methane,2012} - PE_{power,2012} - PE_{biomass,2012} - LE_{methane,2012,expost}$	26,861	tCO ₂ e

c) Comparison and $ER_{methane,y}$ results

Year	$BE_{methane,y,expost} - PE_{methane,y,expost} - LE_{methane,y,expost}$ (tCO ₂ e)	$MD_{methane,y} - PE_{power,y} - PE_{biomass,y} - LE_{methane,y,expost}$ (tCO ₂ e)	$ER_{methane,y}$ (tCO ₂ e)
2011	10,889	17,291	10,889

2012	20,904	26,861	20,904
------	--------	--------	--------

2. Electricity Component:

As per registered PDD, the $ER_{\text{electricity},y}$ is decided with following formula:

$$ER_y = BE_y - PE_y - \text{Leakage}_y$$

The calculation results are summarized as below:

ER₂₀₁₁

Parameter	Value	Unit	Data source
BE_{2011}	2,221	tCO ₂ e	Calculated
PE_{2011}	0	tCO ₂ e	Justified in PDD
$Leakage_{2011}$	0	tCO ₂ e	Justified in PDD
ER_{2011}	2,221	tCO ₂ e	Calculated

ER₂₀₁₂

Parameter	Value	Unit	Data source
BE_{2012}	3,232	tCO ₂ e	Calculated as monitored data
PE_{2012}	0	tCO ₂ e	Justified in PDD
$Leakage_{2012}$	0	tCO ₂ e	Justified in PDD
ER_{2012}	3,232	tCO ₂ e	Calculated as per Equation (5.1)

3. Total ER

Parameter	Methane recovery component	Electricity component	Total emission reductions
Emission reduction in 2011 (tCO ₂ e)	10,889	2,221	13,110
Emission reduction in 2012 (tCO ₂ e)	20,904	3,232	24,136
Total of the monitoring period (tCO ₂ e)	31,793	5,453	37,246

E.5. Comparison of actual emission reductions with estimates in the CDM-PDD

>>

Item	Values estimated in ex-ante calculation of registered PDD	Actual values achieved during this monitoring period
Emission reductions or GHG removals by sinks (tCO₂e) (28/07/2011-31/12/2011)	26,056⁶	13,110
Emission reductions or GHG removals by sinks (tCO₂e) (01/01/2012-31/08/2012)	40,495⁷	24,136
Total	66,551	37,246

⁶ As to the registered PDD, the estimated emission reduction for 365 days is 60577, and there are 157 days operation from 28/07/2011 to 31/12/2011, therefore the estimated for the emission reduction covering this monitoring period (28/07/2011 to 31/12/2011) is calculated as following: $60,577/365 * 157 = 26,056$ tCO₂e.

⁷ As to the registered PDD, the estimated emission reduction for 365 days is 60577, and there are 244 days operation from 01/01/2012 to 31/08/2012, therefore the estimated for the emission reduction covering this monitoring period (01/01/2012 to 31/08/2012) is calculated as following: $60,577/365 * 244 = 40,495$ tCO₂e.

E.6. Remarks on difference from estimated value in the PDD

>>

The actual emission reductions are only 55.97% of the emission reductions estimated in the PDD. Compared with estimated value in the PDD, the actual emission reductions are significantly lower. That is because the quality of raw material supplied by the market decreased and the water usage increased for the production line. Consequently, the COD content entered to the anaerobic digesters decreased, and therefore the COD removed by the anaerobic digester decreased by 50%. As a result, only 55.97% of emission reduction was achieved compared with the estimation in registered PDD.

E.7. Actual emission reductions or net anthropogenic GHG removals by sinks during the first commitment period and the period from 1 January 2013 onwards

Not applicable.

History of the document

Version	Date	Nature of revision
02.0	3 December 2012	Revision required to introduce a provision on reporting actual emission reductions or net anthropogenic GHG removals by sinks during the 1 st commitment period and the period from 1 January 2013 onwards.
01	EB 54, Annex 34 28 May 2010	Initial adoption.
Decision Class: Regulatory Document Type: Guideline, Form Business Function: Issuance		