

BUNDLED SOLAR POWER PROJECT BY VECTOR GREEN ENERGY PRIVATE LIMITED



Document Prepared by EKI Energy Services Limited

Project Title	Bundled Solar Power Project by Vector Green Energy Private Limited
Version	02
Date of Issue	16-July-2018
Monitoring Period	28-June-2016 to 22-May-2018 (First and last date included)
Prepared By	Kingshuk Das Asst. Manager- Operations EKI Energy Services Limited
Contact	EnKing Embassy, Office No. 201, Plot 48, Scheme 78, Part 2 Vijay Nagar, Near brilliant Convention Centre, Indore- 452010 Madhya Pradesh, India Website: www.enkingint.org Email ID: kingshuk@enkingint.org T: +91 731 42 89 086, M: +91 9589899647

Table of Contents

1	Project Details.....	3
1.1	Summary Description of the Project and its Implementation Status.....	3
1.2	Sectoral Scope and Project Type.....	4
1.3	Project Proponent.....	4
1.4	Other Entities Involved in the Project.....	5
1.5	Project Start Date.....	5
1.6	Project Crediting Period.....	5
1.7	Project Scale and Estimated GHG Emission Reductions or Removals.....	5
1.8	Description of the Project Activity.....	6
1.9	Project Location.....	8
1.10	Conditions Prior to Project Initiation.....	9
1.11	Compliance with Laws, Statutes and Other Regulatory Frameworks.....	9
1.12	Ownership and Other Programs.....	10
1.12.1	Project Ownership.....	10
1.12.2	Emissions Trading Programs and Other Binding Limits.....	10
1.12.3	Other Forms of Environmental Credit.....	10
1.12.4	Participation under Other GHG Programs.....	11
1.12.5	Projects Rejected by Other GHG Programs.....	11
1.13	Additional Information Relevant to the Project.....	11
2	Application of Methodology.....	12
2.1	Title and Reference of Methodology.....	12
2.2	Applicability of Methodology.....	12
2.3	Project Boundary.....	16
2.4	Baseline Scenario.....	17
2.5	Additionality.....	18
2.6	Methodology Deviations.....	28
3	Estimated GHG Emission Reductions and Removals.....	28
3.1	Baseline Emissions.....	28
3.2	Project Emissions.....	33
3.3	Leakage.....	33
3.4	Estimated Net GHG Emission Reductions and Removals.....	33
4	Monitoring.....	34
4.1	Data and Parameters Available at Validation.....	34
4.2	Data and Parameters Monitored.....	35
4.3	Monitoring Plan.....	36
5	Safeguards.....	38
5.1	No Net Harm.....	38
5.2	Environmental Impact.....	38
5.3	Local Stakeholder Consultation.....	38
5.4	Public Comments.....	40
6	Achieved GHG Emission Reductions and Removals.....	40
6.1	Data and Parameters Monitored.....	40
6.2	Baseline Emissions.....	40
6.3	Project Emissions.....	41
6.4	Leakage.....	41
6.5	Net GHG Emission Reductions and Removals.....	41
	Appendix 1: Input Parameters and Assumptions for Additionality Assessment.....	42
	Appendix 2: Calibration and Meter Details.....	48

1 PROJECT DETAILS

1.1 Summary Description of the Project and its Implementation Status

The main purpose of this project activity is to generate clean form of electricity through renewable solar energy source. The project is a bundled project activity which involves installation of 105 MW solar project in different states of India through SPVs.

Over the 10 years of first crediting period, the project will replace anthropogenic emissions of greenhouse gases (GHG's) estimated to be approximately 163,888 tCO₂e per year, thereon displacing 169,781 MWh/year amount of electricity from the generation-mix of power plants connected to the Indian grid, which is mainly dominated by thermal/fossil fuel based power plant.

The details of the SPVs for the project and their location of installation are mentioned in the table below:-

Name of SPVs	Capacity in MW	COD	Connection with Grid	State	Usage
Winsol Solar Fields (Polepally) Pvt Ltd	15 MW	01/07/2016	Indian Grid	Telangana	Sale to State Discom
	50 MW	31/12/2016	Indian Grid	Telangana	Sale to State Discom
Hindupur Solar Park Pvt Ltd	40 MW	28/06/2016	Indian Grid	Andhra Pradesh	Sale to State Discom

These are the SPVs of Vector Green Energy Private Limited and the project is promoted by Vector Green Energy Private Limited.

Sectoral Scope : 01 - Energy industries (renewable / non-renewable sources)
Project Type : I - Renewable Energy Projects
Project Category : Grid-connected electricity generation from renewable sources
 ACM0002- Version 18.1

Tools referred with above methodology are:

Tool to calculate the emission factor for an electricity system¹ - Version 06.0 (EB 97, Annex 07)

Scenario existing prior to the implementation of project activity:

The scenario existing prior to the implementation of the project activity, is electricity delivered to the grid by the project activity that would have otherwise been generated by the operation of grid-connected power plants and by the addition of new generation sources, as reflected in the combined margin (CM) calculations described in the "Tool to calculate the emission factor for an electricity system".

Baseline Scenario:

As per the applicable methodology, a Greenfield power plant is defined as "a new renewable energy power plant that is constructed and operated at a site where no renewable energy power plant was operated prior to the implementation of the project activity".

¹ <http://cdm.unfccc.int/methodologies/PAMethodologies/tools/am-tool-07-v6.pdf>

As the project activity falls under the definition of a Greenfield power plant, the baseline scenario as per paragraph 24 of Section 5.2.1 of applied methodology is the following:

If the project activity is the installation of a Greenfield power plant, the baseline scenario is electricity delivered to the grid by the project activity would have otherwise been generated by the operation of grid-connected power plants and by the addition of new generation sources, as reflected in the combined margin (CM) calculations described in the "Tool to calculate the emission factor for an electricity system".

Hence, pre-project scenario and baseline scenario are the same.

Total emission reductions achieved in this monitoring period:

During the Current Monitoring Period from 28/06/2016 to 22/05/2018 (First and last date included) the project activity has supplied 321,387 MWh of electricity, and thus contributing to the GHG reductions 310,233 tCO₂e.

1.2 Sectoral Scope and Project Type

The project activity falls under the following Sectoral scope and Project Type:

Sectoral Scope : 01 - Energy industries (renewable / non-renewable sources)
Project Type : I - Renewable Energy Projects
Project Category : Grid-connected electricity generation from renewable sources
 ACM0002- Version 18.1²

The project is not a grouped project activity.

1.3 Project Proponent

Organization name	Winsol Solar Fields (Polepally) Pvt Ltd
Contact person	Mr Lokesh Jeengar
Title	GM (Power Sales & Business)
Address	Office No. 504/2, 5th Floor, White House Block I, 6-3-1192/1/1, Kundanbagh, Begumpet, Hyderabad Telangana- 500016 India
Telephone	-
Email	-

Organization name	Hindupur Solar Park Pvt Ltd
Contact person	Mr Lokesh Jeengar
Title	GM (Power Sales & Business)
Address	Office No. 504/2, 5th Floor, White House Block I, 6-3-1192/1/1, Kundanbagh, Begumpet, Hyderabad Telangana- 500016 India

² <http://cdm.unfccc.int/methodologies/DB/5725LCHYPYM4I1V8OD9SFYVAMFFWNP>

Telephone	-
Email	-

1.4 Other Entities Involved in the Project

Organization name	EKI Energy Services Limited
Role in the project	Project Consultant
Contact person	Manish Dabkara
Title	CEO & MD
Address	EnKing Embassy, Office No 201, Plot 48, Scheme 78, Part 2, Vijay Nagar, Indore- 452010, Madhya Pradesh, India.
Telephone	+91-731-4289086
Email	manish@enkingint.org

1.5 Project Start Date

Start date of the project activity is the earliest date of interconnection with the grid i.e. 28-06-2016. This is the date of commissioning of 40 MW solar PV project activity by Hindupur Solar Park Pvt Ltd.

The details of the commissioning dates of the individual project activity are mentioned in the section 1.1 of this report.

1.6 Project Crediting Period

Crediting Period Start date: 28-June-2016

Crediting Period End date: 27-June-2026

The project activity adopts renewable crediting period of 10 years period which can be renewed for maximum 2 times.

1.7 Project Scale and Estimated GHG Emission Reductions or Removals

The project involves setting up of 105 MW of Solar power project.

Project Scale	
Project	✓
Large project	

As the estimated annual average GHG emission reductions or removal per year is 163,888 tCO₂e which is less than 300,000 tonnes of CO₂e per year, thus the project falls in the category of Project.

Year	Estimated GHG emission reductions or removals (tCO ₂ e)
Year 1	126,944
Year 2	167,993
Year 3	167,993
Year 4	167,993
Year 5	167,993
Year 6	167,993
Year 7	167,993
Year 8	167,993
Year 9	167,993
Year 10	167,993
Total estimated ERs	1,638,881
Total number of crediting years	10
Average annual ERs	163,888

1.8 Description of the Project Activity

The project activity involves the installation of Solar PV project. The total installed capacity of the project is 105 MW of Solar PV plant located at different states in India. The project is promoted by **Vector Green Energy Private Limited**.

The Project activity is a new facility (Greenfield) and the electricity generated by the project will be exported to the Indian electricity grid. The project will therefore displace an equivalent amount of electricity which would have otherwise been generated by fossil fuel dominant electricity grid. The Project Proponent plans to avail the VCS benefits for the project.

In the Pre- project scenario the entire electricity, delivered to the grid by the project activity, would have otherwise been generated by the operation of grid-connected power plants and by the addition of new generation sources.

The project shall result in replacing anthropogenic emissions of greenhouse gases (GHG's) estimated to be approximately 163,888 tCO₂e per year, thereon displacing 169,781 MWh/year amount of electricity from the grid over the 10 years crediting period.

Solar PV Project Technology Details –

The project activity aims to harness solar energy through installation of Solar PV project with total installed capacity of 105 MW.

The technical specification of each SPV will be mentioned during validation of project activity.

The technical specification of 40 MW plant interconnection with grid on 28-06-2016 by Hindupur Solar Park Pvt Ltd are as follows:

SI. No.	Technical details of the equipment ³	Description
1	Make of modules installed	First solar series4V2
2	No. of the modules installed	432300
3	Make & Model of Invertor	ABB
4	Number of Inverters	40
5	Make & Number of Transformers	Power transformer- 2, make-CROMPTON GREAVES LTD ; Inverter transformers- 20, make- VOLTAMP TRANSFORMER LTD

The technical specification of 15 MW plant interconnection with grid on 01-07-2016 by Winsol Solar Fields (Polepally) Pvt Ltd are as follows:

SI. No.	Technical details of the equipment ⁴	Description
1	Make of modules installed	First solar series4V2
2	No. of the modules installed	172788
3	Make & Model of Invertor	ABB
4	Number of Inverters	15
5	Make & Number of Transformers	Power transformer- 1, make-Schneider Electric ; Inverter transformers-8, make-VOLTAMP

The technical specification of 50 MW plant interconnection with grid on 31-12-2016 by Winsol Solar Fields (Polepally) Pvt Ltd are as follows:

SI. No.	Technical details of the equipment ⁵	Description
1	Make of modules installed	First solar
2	No. of the modules installed	551840
3	Make & Model of Invertor	SMA, ABB
4	Number of Inverters	22
5	Make & Number of Transformers	Power transformer- 2, make-Bharat Beejali ; Inverter transformers-22, make-Voltamp, Shilchar

³ It is to be noted that in future there is possibility of change in module configuration, however project capacity in total will remain same as 40 MW.

⁴ It is to be noted that in future there is possibility of change in module configuration, however project capacity in total will remain same as 15 MW.

⁵ It is to be noted that in future there is possibility of change in module configuration, however project capacity in total will remain same as 50 MW.

1.9 Project Location

The details of the project locations are mentioned in the table below

Name of SPVs	Capacity (MW)	State	Village	Mandal	District	Latitude (N)	Longitude (E)
Winsol Solar Fields (Polepally) Pvt Ltd	15 MW	Telangana	Karoor	Nawabpet	Mahabubnagar	16°51'49.9"	78°05'33.6"
	50 MW	Telangana	Indur	Peddumal	Vikarabad	17°20'41.4"	77°36'56.6"
Hindupur Solar Park Pvt Ltd	40 MW	Andhra Pradesh	Nelapalle	Peddapanjani	Chittoor	13°20'24"	78°30'00.0"

The project locations have been shown in the map below



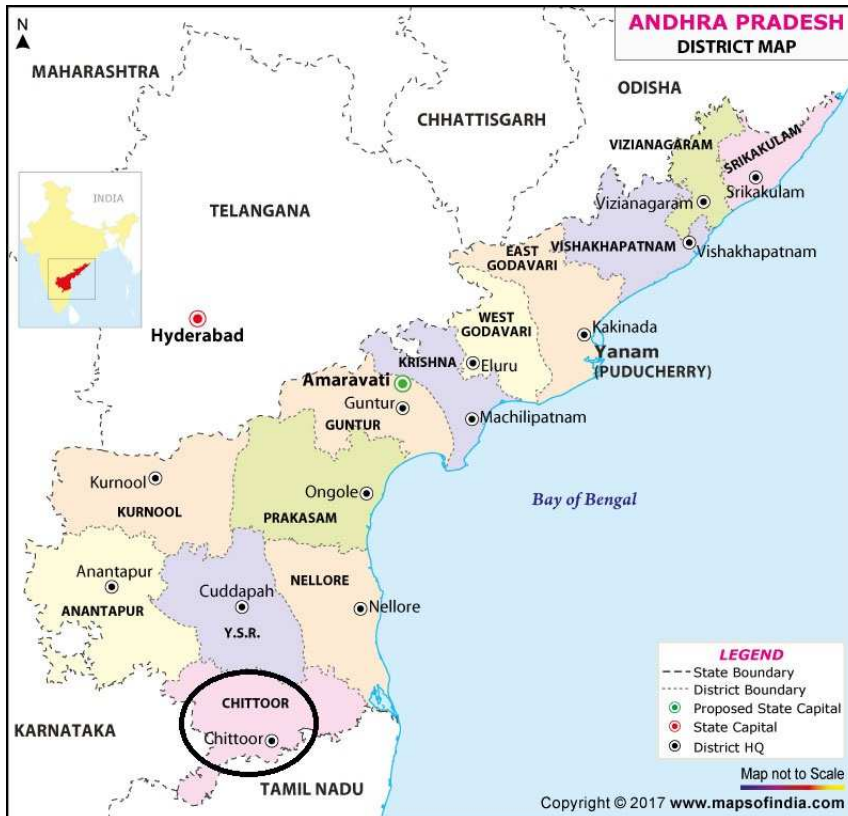

1.10 Conditions Prior to Project Initiation

The project is a Greenfield solar power project and does not involve generation of GHG emissions for the purpose of their subsequent reduction, removal or destruction. Thus prior to project initiation, there was nothing at site.

In absence of project activity, the continuation of current practise i.e generation of equivalent amount electricity would have been generated from grid connected fossil fuel dominated power plants. Thus for project activity baseline scenario is electricity delivered to the grid by the project activity would have otherwise been generated by the operation of grid-connected power plants and by the addition of new generation sources.

1.11 Compliance with Laws, Statutes and Other Regulatory Frameworks

The Project has received all the necessary approvals for development and commissioning for the proposed 105 MW Solar PV project from the respective State Nodal Agencies and is in compliance to the local laws and regulations.

As per Central Pollution Control Board (Ministry of Environment & Forests, Govt. of India), final document on revised classification of Industrial Sectors under Red, Orange, Green and White Categories (February 29, 2016).

The newly introduced White category of industries pertains to those industrial sectors which are practically non-polluting such as Biscuit trays etc. from rolled PVC sheet (using automatic vacuum

forming machines), Cotton and woollen hosiers making (Dry process only without any dying/washing operation), Electric lamp (bulb) and CFL manufacturing by assembling only, Scientific and mathematical instrument manufacturing, Solar power generation through photovoltaic cell, wind power and mini hydel power (less than 25 MW).

There shall be no necessity of obtaining the Consent to Operate” for White category of industries. An intimation to concerned SPCB / PCC shall suffice.

Since project activity falls under white category and the non-polluting nature of project fulfils the compliance to the local laws and regulations. The state nodal agency approval is submitted to DOE.

1.12 Ownership and Other Programs

1.12.1 Project Ownership

As per VCS Program Definitions version 3.7, the project ownership is the legal right to control and operate the project activities.

Vector Green Energy Private Limited is the project proponent (PP) of project activity and they have formed each SPVs which have the legal right to control and operate the project activities.

The project ownership has been demonstrated through below supporting documents:

1. **Commissioning certificates** – The letter from respective State Nodal Agency to the SPVs of Vector Green Energy Private Limited i.e. Winsol Solar Fields (Polepally) Pvt Ltd and Hindupur Solar Park Pvt Ltd for registration of commissioning of generation facility indicates that PP have the legal right to control and operate the project activities.
2. **Contract with EPC contractor** – The purchase order on the name of Winsol Solar Fields (Polepally) Pvt Ltd and Hindupur Solar Park Pvt Ltd indicates that PP have the legal right to control and operate the project activities.

Based on above evidences, the project ownership of each SPV is demonstrated and **Vector Green Energy Private Limited** is authorised on the behalf of all SPVs.

1.12.2 Emissions Trading Programs and Other Binding Limits

Net GHG emission reductions or removals generated by the Project will not be used for compliance with an emissions trading program or to meet binding limits on GHG emissions in any Emission Trading program or other binding limits.

1.12.3 Other Forms of Environmental Credit

The Project has no intend to generate any other form of GHG-related environmental credit for GHG emission reductions or removals claimed under the VCS Program.

However it can be crosschecked that PP is not claiming REC benefits, the same can be verified with the REC accreditation body of India⁶.

1.12.4 Participation under Other GHG Programs

The project has neither been registered nor seeking registration under any other GHG programs. The project is seeking registration only in VCS program.

1.12.5 Projects Rejected by Other GHG Programs

The Project is not rejected by other GHG programs.

1.13 Additional Information Relevant to the Project

Eligibility Criteria

This is not a grouped project activity. Thus, this section is not applicable for this project.

Leakage Management

Not applicable to the project activity.

Commercially Sensitive Information

No commercially sensitive information has been excluded from the public version of the project description.

Sustainable Development

Contribution to sustainable development:

Ministry of Environment and Forests, has stipulated economic, social, environment and technological well-being as the four indicators of sustainable development. The project contributes to sustainable development using the following ways.

Social well-being: The project would help in generating employment opportunities during the construction and operation phases. The project activity will lead to development in infrastructure in the region like development of roads and also may promote business with improved power generation.

Economic well-being: The project is a clean technology investment in the region, which would not have been taken place in the absence of the VCS benefits the project activity will also help to reduce the demand supply gap in the state.

⁶ https://recregistryindia.nic.in/index.php/general/publics/accredited_regens_pdf

The project activity will generate power using zero emissions Solar PV based power generation which helps to reduce GHG emissions and specific pollutants like SO_x, NO_x, and SPM associated with the conventional thermal power generation facilities.

Technological well-being: The successful operation of project activity would lead to promotion of Solar based power generation and would encourage other entrepreneurs to participate in similar projects

Environmental well-being: Solar being a renewable source of energy, it reduces the dependence on fossil fuels and conserves natural resources which are on the verge of depletion. Due to its zero emission the Project activity also helps in avoiding significant amount of GHG emissions.

Further Information

Not Applicable

2 APPLICATION OF METHODOLOGY

2.1 Title and Reference of Methodology

Title : Grid-connected electricity generation from renewable sources
Reference : The project activity meets the eligibility criteria of large scale project as it is more than 15 MW
Methodology : ACM0002: Grid-connected electricity generation from renewable sources - Version 18.1⁷
Type I : Energy industries (renewable / non-renewable sources)
Category : Approved Consolidated Methodology (ACM0002)

Tools referred with above methodology and applicable for project activity are:

- Tool to calculate the emission factor for an electricity system⁸ - Version 06.0 (EB 97, Annex 07)
- Methodological Tool- Tool for the demonstration and assessment of additionality⁹ - Version 07.0.0 (EB 70, Annex 08)

2.2 Applicability of Methodology

The project activity involves generation of grid connected electricity from renewable solar energy. The project activity has a proposed capacity of 105 MW which will qualify for a large scale CDM project activity under Type-I of the large scale methodologies. The project status is corresponding to the methodology ACM0002 version 18.1 and applicability of methodology are discussed below.

⁷ <http://cdm.unfccc.int/methodologies/DB/5725LCHYPYM411V8OD9SFYVAMFFWNP>

⁸ <http://cdm.unfccc.int/methodologies/PAMethodologies/tools/am-tool-07-v6.pdf>

⁹ <http://cdm.unfccc.int/methodologies/PAMethodologies/tools/am-tool-01-v7.0.0.pdf>

Applicability Criterion	Project Case
<p>1. This methodology is applicable to grid-connected renewable energy power generation project activities that:</p> <ul style="list-style-type: none"> (a) Install a Greenfield power plant; (b) Involve a capacity addition to (an) existing plant(s); (c) Involve a retrofit of (an) existing operating plants/units; (d) Involve a rehabilitation of (an) existing plant(s)/unit(s); or (e) Involve a replacement of (an) existing plant(s)/unit(s) 	<p>The project activity is a Renewable Energy Project i.e. Solar Power Project which falls under applicability criteria option 1 (a) i.e., "Install a Greenfield power plant". Hence the project activity meets the given applicability criterion.</p>
<p>2. The methodology is applicable under the following conditions:</p> <ul style="list-style-type: none"> (a) The project activity may include renewable energy power plant/unit of one of the following types: hydro power plant/unit with or without reservoir, wind power plant/unit, geothermal power plant/unit, solar power plant/unit, wave power plant/unit or tidal power plant/unit; (b) In the case of capacity additions, retrofits, rehabilitations or replacements (except for wind, solar, wave or tidal power capacity addition projects the existing plant/unit started commercial operation prior to the start of a minimum historical reference period of five years, used for the calculation of baseline emissions and defined in the baseline emission section, and no capacity expansion, retrofit, or rehabilitation of the plant/unit has been undertaken between the start of this minimum historical reference period and the implementation of the project activity. 	<p>The option (a) of applicability criteria 2 is applicable as project is renewable energy solar power plant/unit.</p>
<p>3. In case of hydro power plants, one of the following conditions shall apply:¹⁰</p> <ul style="list-style-type: none"> (a) The project activity is implemented in existing single or multiple reservoirs, with no change in the volume of any of the reservoirs; or (b) The project activity is implemented in existing single or multiple reservoirs, where the volume of the reservoir(s) is increased and the power density calculated using equation (3), is greater than 4 W/m²; or (c) The project activity results in new single or 	<p>The project is installation of new solar based electricity generation plants (not a hydro power plant). Hence this criteria is not applicable.</p>

¹⁰ Project participants wishing to undertake a hydroelectric project activity that result in a new reservoir or an increase in the volume of an existing reservoir, in particular where reservoirs have no significant vegetative biomass in the catchments area, may request a revision to the approved consolidated methodology.

<p>multiple reservoirs and the power density, calculated using equation (3), is greater than 4 W/m^2; or</p> <p>(d) The project activity is an integrated hydro power project involving multiple reservoirs, where the power density for any of the reservoirs, calculated using equation (3), is lower than or equal to 4 W/m^2, all of the following conditions shall apply:</p> <p>(i) The power density calculated using the total installed capacity of the integrated project, as per equation (4), is greater than 4 W/m^2;</p> <p>(ii) Water flow between reservoirs is not used by any other hydropower unit which is not a part of the project activity;</p> <p>(iii) Installed capacity of the power plant(s) with power density lower than or equal to 4 W/m^2 shall be:</p> <p>a. Lower than or equal to 15 MW; and</p> <p>b. Less than 10 per cent of the total installed capacity of integrated hydro power project.</p>	
<p>4. In the case of integrated hydro power projects, project proponent shall:</p>	<p>The project is solar power project and thus the criterion is not applicable to this project activity.</p>
<p>5. Demonstrate that water flow from upstream power plants/units spill directly to the downstream reservoir and that collectively constitute to the generation capacity of the integrated hydro power project; or</p>	<p>The project is solar power project and thus the criterion is not applicable to this project activity.</p>
<p>6. Provide an analysis of the water balance covering the water fed to power units, with all possible combinations of reservoirs and without the construction of reservoirs. The purpose of water balance is to demonstrate the requirement of specific combination of reservoirs constructed under CDM project activity for the optimization of power output. This demonstration has to be carried out in the specific scenario of water availability in different seasons to optimize the water flow at the inlet of power units. Therefore this water balance will take into account seasonal flows from river, tributaries (if any), and rainfall for minimum five years prior to implementation of CDM project activity.</p>	<p>The project is solar power project and thus the criterion is not applicable to this project activity.</p>

<p>7. The methodology is not applicable to:</p> <p>(a) Project activities that involve switching from fossil fuels to renewable energy sources at the site of the project activity, since in this case the baseline may be the continued use of fossil fuels at the site;</p> <p>(b) Biomass fired power plants/units.</p>	<p>(a) The project activity is Greenfield and there is no switching of fossil fuel to renewable energy. Hence the criteria is not applicable to the project activity</p> <p>(b) The project is not a biomass fired power plant. Hence the criteria is not applicable to the project activity.</p>
<p>8. In the case of retrofits, rehabilitations, replacements, or capacity additions, this methodology is only applicable if the most plausible baseline scenario, as a result of the identification of baseline scenario, is “the continuation of the current situation, that is to use the power generation equipment that was already in use prior to the implementation of the project activity and undertaking business as usual maintenance”.</p>	<p>Not applicable, the solar project is a Green field project activity and this project is not the enhancement or up gradation project.</p>
<p>9. In addition, the applicability conditions included in the tools referred to below apply.¹¹</p>	<p>Please refer tables below.</p>

Tool to calculate the emission factor for an electricity system¹² - Version 06.0 (EB 97, Annex 07)

Applicability Criterion	Project Case
<p>This tool may be applied to estimate the OM, BM and/or CM when calculating baseline emissions for a project activity that substitutes grid electricity that is where a project activity supplies electricity to a grid or a project activity that results in savings of electricity that would have been provided by the grid (e.g. demand-side energy efficiency projects).</p>	<p>The project is a grid connected Greenfield Solar power project and thus the tool is applicable.</p>
<p>Under this tool, the emission factor for the project electricity system can be calculated either for grid power plants only or, as an option, can include off-grid power plants. In the latter case, two sub-options under the step 2 of the tool are available to the project participants, i.e. option IIa and option IIb. If option IIa is chosen, the conditions specified in “Appendix 2: Procedures related to off-grid power generation” should be met. Namely, the total capacity of off-grid power plants (in MW) should be at least 10 per cent of the total capacity</p>	<p>Steps involved in calculation of Emission Factor is included in section B.6.3 of the PDD as per the requirement of the tool</p>

¹¹ The condition in the “Combined tool to identify the baseline scenario and demonstrate additionality” that all potential alternative scenarios to the proposed project activity must be available options to project participants; does not apply to this methodology, as this methodology only refers to some steps of this tool.

¹² <http://cdm.unfccc.int/methodologies/PAMethodologies/tools/am-tool-07-v6.pdf>

Applicability Criterion	Project Case
of grid power plants in the electricity system; or the total electricity generation by off-grid power plants (in MWh) should be at least 10 per cent of the total electricity generation by grid power plants in the electricity system; and that factors which negatively affect the reliability and stability of the grid are primarily due to constraints in generation and not to other aspects such as transmission capacity.	
In case of CDM projects the tool is not applicable if the project electricity system is located partially or totally in an Annex I country.	Project is located in non-Annex I country and hence the tool is applicable
Under this tool, the value applied to the CO ₂ emission factor of biofuels is zero.	The project is a Solar project and there is no involvement of biofuels.

- Methodological Tool- Tool for the demonstration and assessment of additionality- Version 07.0.0 (EB 70, Annex 08)

Applicability Criteria has been demonstrated in section on additionality below.

The project activity qualifies as Type I during every year of the crediting period in accordance with applicable provisions for project activity eligibility as discussed above. Also the total installed capacity of project activity is 105 MW which is applicable as per large scale project activities methodology ACM0002: Grid-connected electricity generation from renewable sources Version 18.1. The project capacity will be always remain the same and hence the project activity will always be large scale project activities throughout the crediting period and thereafter.

2.3 Project Boundary

As per ACM0002 version 18.1 - “The spatial extent of the project boundary includes the project power plant and all power plants connected physically to the electricity system that the CDM project power plant is connected to”.

The project boundary includes the solar project, sub-stations, grid and all power plants connected to grid. The proposed project activity will evacuate power to the Indian grid. Therefore the entire Indian grid and all connected power plants have been considered in the project boundary for the proposed VCS project activity.

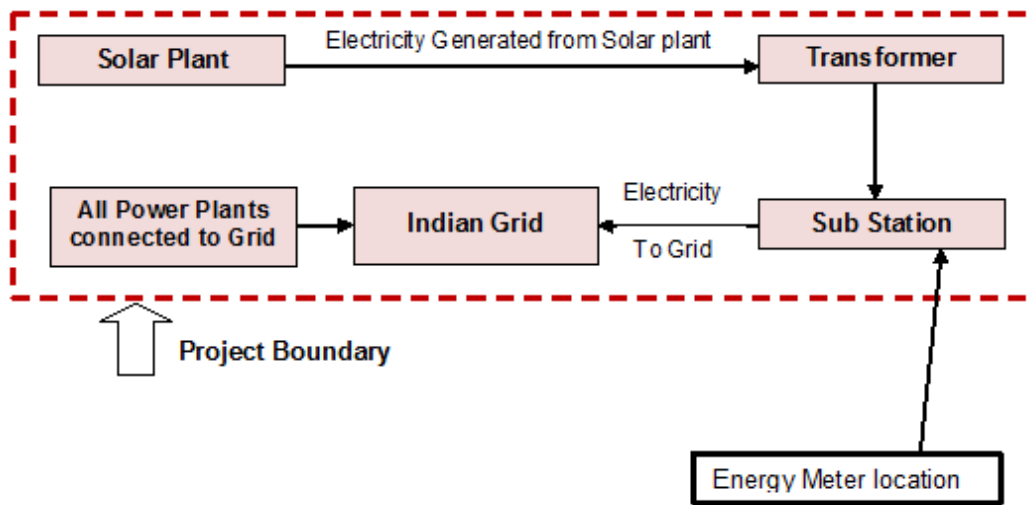

Source		Gas	Included?	Justification/Explanation
Baseline	Grid connected electricity generation.	CO ₂	Yes	Main emission source
		CH ₄	No	Minor emission source
		N ₂ O	No	Minor emission source
		Other	No	No CO ₂ emissions are emitted from the project
Project	Greenfield Solar PV Power Project Activity.	CO ₂	No	No CO ₂ emissions are emitted from the project
		CH ₄	No	Project activity does not emit CH ₄
		N ₂ O	No	Project activity does not emit N ₂ O
		Other	No	Project activity does not emit other forms of GHG emissions

2.4 Baseline Scenario

As per the approved consolidated Methodology ACM0002 (Version 18.1) para 24: *“If the project activity is the installation of a Greenfield power plant, the baseline scenario is electricity delivered to the grid by the project activity would have otherwise been generated by the operation of grid-connected power plants and by the addition of new generation sources, as reflected in the combined margin (CM) calculations described in the “Tool to calculate the emission factor for an electricity system”.*

The project activity involves setting up of solar projects to harness the power of sun to produce electricity and supply to the grid. In the absence of the project activity, the equivalent amount of power would have been supplied by the Indian grid, which is fed mainly by fossil fuel fired plants.

In the absence of the project activity, the equivalent amount of power would have been drawn from the Indian grid. Hence, the baseline for the project activity is the equivalent amount of power from the Indian grid.

The combined margin (EF_{grid,CM,y}) is the result of a weighted average of two emission factor pertaining to the electricity system: the operating margin (OM) and build margin (BM).

Calculations for this combined margin must be based on data from an official source (where available) and made publically available. The CEA database version 12 is the latest available data at the time of PD submission to DOE for validation, hence same is considered for emission factor calculations.

The combined margin of the Indian grid used for the project activity is as follows:

Parameter	Value	Nomenclature	Source
EF _{grid,CM,y}	0.9653 tCO ₂ /MWh	Combined margin CO ₂ emission factor for the project electricity system in year y	Calculated as the weighted average of the operating margin (0.75) & build margin (0.25) values, sourced from Baseline CO ₂ Emission Database, Version 12.0, May 2017 published by Central Electricity Authority (CEA), Government of India
EF _{grid,OM,y}	0.9843 tCO ₂ /MWh	Operating margin CO ₂ emission factor for the project electricity system in year y	Calculated as the last 3 year (2013-14, 2014-15, 2015-16) generation-weighted average, sourced from Baseline CO ₂ Emission Database, Version 12.0, May 2017 published by Central Electricity Authority (CEA), Government of India
EF _{grid,BM,y}	0.9083 tCO ₂ /MWh	Build margin CO ₂ emission factor for the project electricity system in year y	Baseline CO ₂ Emission Database, Version 12.0, May 2017 published by Central Electricity Authority (CEA), Government of India

2.5 Additionality

The table below is only applicable if the proposed project activity is a type of project activity which is deemed automatically additional, as defined by the applied approved methodology or standardized baseline.

Specify the methodology or standardized baseline that establish automatic additionality for the proposed project activity (including the version number and the specific paragraph, if applicable).	NA
Describe how the proposed project activity meets the criteria for automatic additionality in the relevant methodology or standardized baselines.	NA

The present VCS project generates power using Solar PV energy which is a renewable, zero emission source of energy. Baseline considerations for the project are based on approved consolidated baseline methodology ACM0002 (Version 18.1). The methodology requires the project investor to determine the additionality based on "Methodological Tool- Tool for the demonstration and assessment of additionality", Version 7.0.0. The step-wise approach to establish additionality of the project activity has been followed, details of which are provided in the following paragraphs:

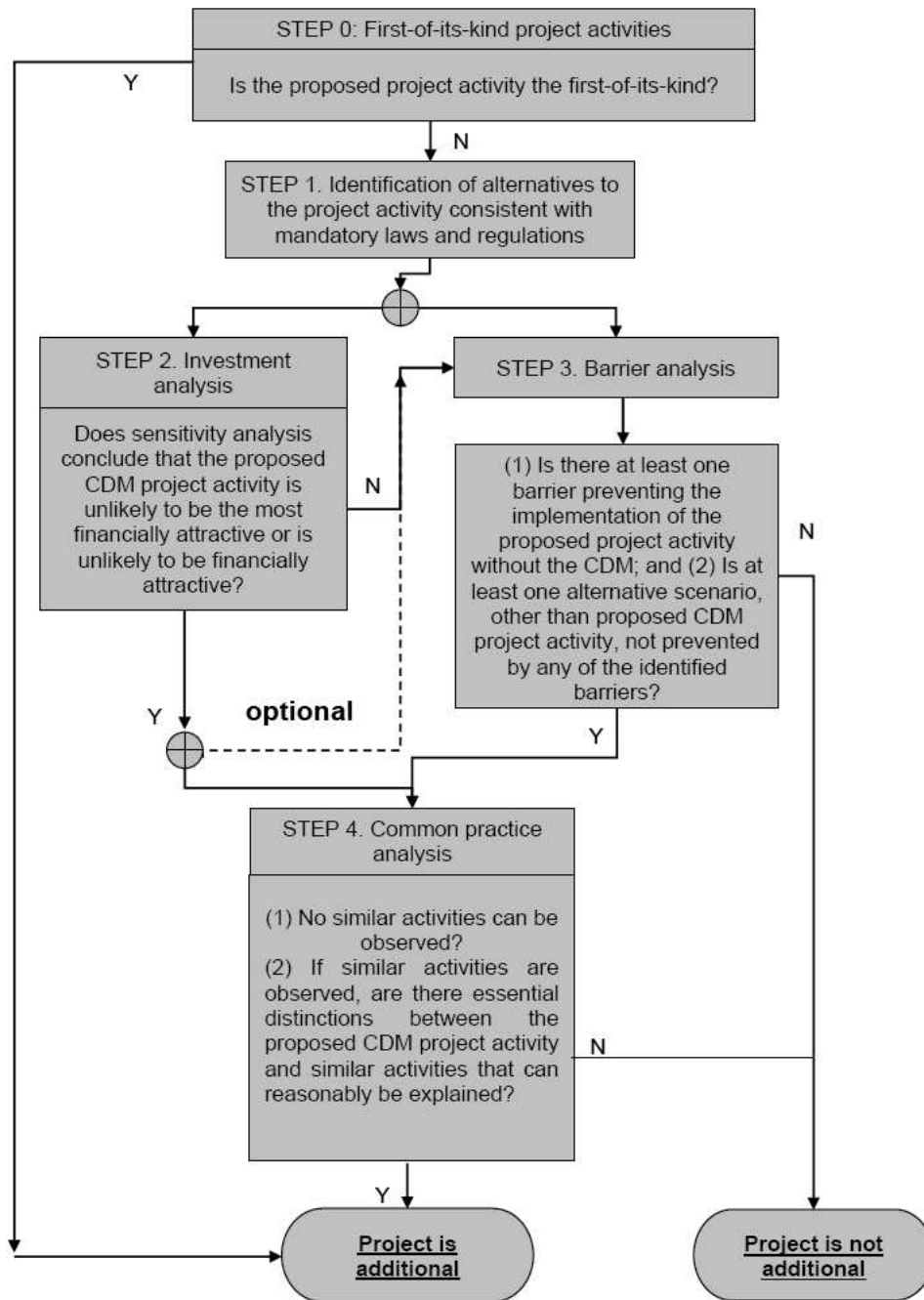

In line with VCS Standard version 3.7, the additionality of the Project activity is ascertained in line with the applicable guidance from the UNFCCC. The demonstration of additionality for the proposed Project activity is being carried out in accordance with the additionality tool provided by the UNFCCC i.e. “Tool for demonstration and assessment of Additionality” Version 07.0.0.,. The tool provides a step-wise approach to demonstrate additionality which is displayed below:

Step 0: Demonstration whether the proposed project activity is the first-of-its-kind

The proposed project activity is not the first-of-its-kind. Hence not applicable.

Step 1: Identification of alternatives to the project activity consistent with current laws and regulations**Sub-step 1a: Define alternatives to the project activity:**

Identify realistic and credible alternative(s) available to the project participants or similar project developers that provide outputs or services comparable with the proposed VCS project activity.

The purpose of the project activity is to generate electrical power using solar energy and feed the electricity generated to the grid. Hence, the following alternatives are considered:

Alternative 1: The proposed project activity not undertaken as a VCS project activity.

The PP could proceed with the implementation of the project without Carbon credit benefits. The electricity produced from the renewable energy project would have been sold to the grid. This is in compliance with all applicable legal and regulatory requirements and can be a part of the baseline. However, the Project activity is not feasible without revenues from sale of Carbon Credits. This argument has been discussed in step 2 of the Additionality section.

Alternative 2: No proposed project activity and equivalent amount of energy would have been produced by the grid electricity system through its currently running power plants and by new capacity addition to the grid i.e. Continuation of the present situation.

The PP would have continued without investment in Project activity with usual business activities. The grid would continue with the fossil fuel based power projects and this would result in GHG emissions. Hence, the new capacity add-on from a fossil fuel based power plant is appropriate, realistic & credible baseline alternative for the project activity.

Outcome of Sub-step 1a: All the realistic alternatives for the project activity have been enlisted above.

Thus though two alternatives are mentioned above as per step of additionality tool, the first alternative is not possible as project activity is not viable without carbon credit benefits and second alternative is the baseline scenario for the project activity as per methodology as mentioned in section 2.4 of joint VCS PD & MR.

It is to be noted that being the green field project activity, “the baseline scenario is electricity delivered to the grid by the project activity would have otherwise been generated by the operation of grid-connected power plants and by the addition of new generation sources, as reflected in the combined margin (CM) calculations described in the “Tool to calculate the emission factor for an electricity system”.

Sub-step 1b: Consistency with mandatory laws and regulations:

The alternative(s) shall be in compliance with all applicable legal and regulatory requirements, even if these laws and regulations have objectives other than GHG reductions, e.g. to mitigate local air pollution. The project activity comes under white category as mentioned in section 1.11 of this document, thus there shall be no necessity of obtaining the Consent to Operate” for White category of industries. Since project activity falls under white category and the non-polluting

nature of project fulfils the compliance to the local laws and regulations (This sub-step does not consider national and local policies that do not have legally-binding status.).

The relevant national laws and regulations pertaining to generation of energy in India are:

- Electricity Act 2003
- National Electricity Policy 2005
- Tariff Policy 2006

The Project activity conforms to all the applicable laws and regulations in India:

- Power generation using renewable energy is not a legal requirement or a mandatory option.
 - There are state and sectoral policies, framed primarily to encourage solar power projects.
 - These policies have also been drafted realizing the extent of risks involved in the projects and to attract private investments.
 - The Indian Electricity Act, 2003 (May 2007 Amendment) does not influence the choice of fuel used for power generation.
 - There is no legal requirement on the choice of a particular technology for power generation.

The both alternatives are in compliance with laws and regulations required. There is no any mandatory requirement to implement the project activity.

Outcome of Sub-step 1b: Hence, both the alternatives enlisted above are found to comply with the mandatory laws and regulations taking into account the enforcement of the legislations in the region or country and EB decisions on national and/or sectoral policies and regulations. Since solar projects are categorised as white category, no any consent to operate required from pollution control board.

However, Alternative 2 has been selected as the appropriate baseline alternative for this project activity in line with methodology.

Step 2: Investment analysis

Determine whether the proposed project activity is economically or financially less attractive than at least one other alternative, identified in step 1, without the revenue from the sale of emission reductions credits. To conduct the investment analysis, use the following sub-steps:

Sub-step 2a: Determine appropriate analysis method

The Project activity envisages to export the power to Indian grid and the revenues from the sale would be generated in accordance with the terms and tariffs established in the Power Purchase Agreement (PPA). Thus, simple cost analysis (Option I) cannot be used as the analysis method as the sale of the units of generated electricity shall result in a revenue stream during the operations of the Project activity.

In the absence of the project activity grid electricity would have been the obvious choice for the Project which requires no investment. Hence investment comparison analysis (Option II) is also not appropriate for the project activity.

After eliminating Option I and Option II, the use of Benchmark analysis (Option III) is the method of analysis that has been selected as the most suitable method. This method determines the attractiveness of the project activity for the investors, as well as provides a measure of the viability of the investment to generate revenues during its operation, as compared with other avenues and investment options. Hence, the Benchmark analysis method is to be employed for analysis of the said project.

Sub-step 2b (Option III): Apply benchmark analysis

The investment analysis using Benchmark analysis approach (Option III) has been chosen. Further, this method illustrates the evaluation of the Project by the PP before the decision to undertake the project was taken and management approval granted.

Choice of Financial Indicator:

According to the "Tool for demonstration and assessment of Additionality", *the financial indicator can be based either on (1) project IRR or (2) equity IRR. There is no general preference between the approaches (1) or (2). The benchmark chosen for analysis shall be fully consistent with the choice of approach.* Therefore in accordance with the guidance, the relevant financial indicator for project activity has been chosen as post tax equity IRR.

Choice of Benchmark:

As per Investment Analysis tool, Required/expected returns on equity are appropriate benchmarks for an equity IRR. The Equity IRR is considered as the financial indicator and the benchmarks used is cost of equity. Hence the benchmarks used are applicable to the project activity and the type of IRR calculation presented

At the time of decision made of project activity, Version 06 of methodological tool "Investment Analysis" (EB 85 Annex 12) was the latest available tool to PP, hence PP has considered the same tool for default value of return on equity. The default value of Return on Equity for Group-1 projects in India is 11.10%.

As per paragraph 7 of Appendix A of the above mentioned document, "In situations where an investment analysis is carried out in nominal terms, project participants can convert the real term values provided in the table below to nominal values by adding the inflation rate. The inflation rate shall be obtained from the **inflation forecast of the central bank of the host country for the duration of the crediting period.** If this information is not available, the target inflation rate of the central bank shall be used. If this information is also not available, then the average forecasted inflation rate for the host country published by the IMF (International Monetary Fund World Economic Outlook) or the World Bank for the next five years after the start of the project activity shall be used".

Default Value Benchmark:

As per para 20 of EB 85, Annex 12 the cost of equity is determined by selecting the values provided in the Appendix, i.e. Default values for cost of equity (expected return on equity) is presented below:

Appendix in EB 92, Annex 5 specifies default value of expected return on equity in real terms for Energy Industries (Group 1) in India = **11.10%**

The Required return on equity (benchmark) was computed in the following manner:

Nominal Benchmark¹³ = $\{(1+\text{Real Benchmark}) \times (1+\text{Inflation rate})\} - 1$

Where:

- Default value for Real Benchmark = 11.10% (as per Appendix of EB 85, Annex 12)
- Inflation Rate forecast for by Reserve Bank of India (RBI) (i.e. Central Bank of India) for India.

Benchmark estimation:**(i) For the 15 MW Solar Project by Winsol Solar Fields (Polepally) Pvt Ltd**

Appendix in EB 85, Annex 12 specifies default value of expected return on equity in real terms for Energy Industries (Group 1) in India = **11.10%**

Inflation Forecast for India as per RBI website¹⁴:

Since RBI publishes the inflation forecast for 5 years and 10 years, PP has considered the maximum 10 year inflation considering the renewable crediting period of total 30 years.

Benchmark Calculations	Value	Sources Link	Document Date	Decision making Date
Default Value for India as per UNFCCC guidelines	11.10%	EB 85 Annex 12	24-07-15	10-02-2016
Inflation forecast (WPI Mean) as per RBI for 10yrs	3.60%	https://rbi.org.in/Scripts/PublicationsView.aspx?id=16731	05-02-16	
Benchmark (with 10yrs Forecast)	15.10%	Calculated		

Thus benchmark of **15.10%** has been selected for this project activity.

(ii) For the 50 MW Solar Project by Winsol Solar Fields (Polepally) Pvt Ltd

Appendix in EB 85, Annex 12 specifies default value of expected return on equity in real terms for Energy Industries (Group 1) in India = **11.10%**

Inflation Forecast for India as per RBI website¹⁵:

¹³ As per Fisher Equation, https://en.wikipedia.org/wiki/Fisher_equation

¹⁴ <https://rbi.org.in/Scripts/PublicationsView.aspx?id=16731>

¹⁵ <https://rbi.org.in/Scripts/PublicationsView.aspx?id=16731>

Since RBI publishes the inflation forecast for 5 years and 10 years, PP has considered the maximum 10 year inflation considering the renewable crediting period of total 30 years.

Benchmark Calculations	Value	Sources Link	Document Date	Decision making Date
Default Value for India as per UNFCCC guidelines	11.10%	EB 85 Annex 12	24-07-15	10-02-2016
Inflation forecast (WPI Mean) as per RBI for 10yrs	3.60%	https://rbi.org.in/Scripts/PublicationsView.aspx?id=16731	05-02-16	
Benchmark (with 10yrs Forecast)	15.10%	Calculated		

Thus benchmark of **15.10%** has been selected for this project activity.

(iii) For the 40 MW Solar Project by Hindupur Solar Park Pvt Ltd

Appendix in EB 85, Annex 12 specifies default value of expected return on equity in real terms for Energy Industries (Group 1) in India = **11.10%**

Inflation Forecast for India as per RBI website¹⁶:

Since RBI publishes the inflation forecast for 5 years and 10 years, PP has considered the maximum 10 year inflation considering the renewable crediting period of total 30 years.

Benchmark Calculations	Value	Sources Link	Document Date	Decision making Date
Default Value for India as per UNFCCC guidelines	11.10%	EB 85 Annex 12	24-07-15	10-02-2016
Inflation forecast (WPI Mean) as per RBI for 10yrs	3.60%	https://rbi.org.in/Scripts/PublicationsView.aspx?id=16731	05-02-16	
Benchmark (with 10yrs Forecast)	15.10%	Calculated		

Thus benchmark of **15.10%** has been selected for this project activity.

Sub-step 2c: Calculation and comparison of financial indicators (only applicable to Options II and III):

The Post tax Equity IRR is evaluated for the entire lifetime of the project activity, i.e. 25 years. It is calculated based on the cash outflows from and cash inflows into the project activity.

Key Assumptions supporting financial projections are provided in excel spreadsheet to the DOE and the same has been summarized in Appendix-1 of this report.

Based on result of IRR excel spreadsheets, equity IRR is less than Benchmark.

¹⁶ <https://rbi.org.in/Scripts/PublicationsView.aspx?id=16731>

This substantiates that the investment is not financially attractive (Equity IRR for the project activity is less than the Benchmark). Thus it can be easily concluded that project activity is additional & is not business as usual scenario.

Sub-step 2d: Sensitivity Analysis

Addressing Guidance 28 & 29 of EB 85, Annex 12, following factors has been subjected to sensitivity analysis:

1. PLF
2. O&M Cost
3. Project Cost
4. Tariff

The rationale of sensitivity is, "The ultimate objective of the sensitivity analysis is to determine the likelihood of the occurrence of a scenario other than the scenario presented, in order to provide a cross-check on the suitability of the assumptions used in the development of the investment analysis."

The results of sensitivity analysis show that even with a variation of +10% & -10% in project cost, O&M cost, PLF and Tariff Rate Equity IRR is significantly lower than the benchmark. And it is evident from the results given above; the project remains additional even under the most favourable conditions.

Probability to breach the benchmark:
Sensitivity Parameter 1 : PLF
PLF considered in financials for is as per Third Party DPR in line with “Guidelines for the reporting and validation of Plant load factors” stated in EB48 Annex11 option 3(b). Hence, variation in PLF of more than 10% is unlikely to happen as the PLF has been reported as per the Third Party Report based on long term data.
Sensitivity Parameter 2 : O&M
The sensitivity analysis reveals that O&M will breach the benchmark at negative values and is hypothetical case. Since the O&M cost is subject to escalation (as evidence by the O&M agreement) and also subject to inflationary pressure, any reduction in the O&M costs is highly unlikely. Hence, the reduction in the O&M cost is highly unlikely.
Sensitivity Parameter 3 : Project Cost
Project Cost for financial analysis is considered from DPR of the project activity, being available at the time of investment making decision to go ahead with the project activity. The actual project cost is lower than the DPR cost. Since the Purchase Order cost is firm, there is no possibility of project cost going below this level. However, Sensitivity is carried out for threshold level below which benchmark is not breached.
Sensitivity Parameter 4 : Tariff Rate
The tariff is determined by PPA which is fixed for entire lifetime of the project activity. Hence, there is no probability to get variation for the same. However, Sensitivity is carried out for +/- 10% even then the benchmark is not breached.

Outcome of Step 2:

This substantiates that the investment is not financially attractive (Equity IRR for the project activity is less than the Benchmark Equity IRR) for any of the investor. Thus it can be easily concluded that project activity is additional & is not business as usual scenario.

Step 3: Barrier analysis

Barrier analysis has not been used.

Step 4: Common practice analysis

For the concerned project activity, Common Practice Analysis has been carried out for 105 MW capacity Solar PV Project as all SPVs are developed under **Vector Green Energy Private Limited**.

Stepwise approach for common practice analysis has been carried out as per Methodological tool “Common Practice”, version 03.1 EB 84, Annex 7:

Step (1): Calculate applicable capacity or output range as +/-50% of the total design capacity or output of the proposed project activity.

Range	Capacity	Unit
+50%	157.5	MW
Capacity of the proposed project activity	105	MW
-50%	52.5	MW

Step (2): Identify similar projects (both CDM and non-CDM) which fulfil all of the following conditions:

- (a) The projects are located in the applicable geographical area;
- (b) The projects apply the same measure as the proposed project activity;
- (c) The projects use the same energy source/fuel and feedstock as the proposed project activity, if a technology switch measure is implemented by the proposed project activity;
- (d) The plants in which the projects are implemented produce goods or services with comparable quality, properties and applications areas (e.g. clinker) as the proposed project plant;
- (e) The capacity or output of the projects is within the applicable capacity or output range calculated in Step 1;
- (f) The projects started commercial operation before the project design document (CDM-PDD) is published for global stakeholder consultation or before the start date of proposed project activity, whichever is earlier for the proposed project activity.

Identification of the similar projects (CDM and non-CDM) is carried out as per sub-steps of Step (2) as follows:

- a) As the projects are located in Andhra Pradesh and Telangana states of India, therefore, projects in the geographical area of Andhra Pradesh and Telangana have been chosen for analysis. The project activity involves generation of electricity from solar energy. The project activity are located in the states of Andhra Pradesh and Telangana in India and the policy applicable for the solar projects is regulated by respective state policy. The policies/tariff for each state is regulated by State Electricity Regulatory Commissions of respective states and they differ for respective states. The project implemented in different states are claimed as different since the policies and regulations differ in each state. Each state have different policies regarding renewable energy, hence Andhra Pradesh and Telangana states are considered as geographical region for common practise analysis.
- b) The project activity is a green-field solar power project and uses measure (b) “Switch of technology with or without change of energy source including energy efficiency improvement as

well as use of renewable energies". Therefore, projects applying same measure (b) are candidates for similar projects.

c) The energy source used by the project activity is solar. Hence, only solar energy projects have been considered for analysis.

d) The project activity produces electricity; therefore, all power plants that produce electricity are candidates for similar projects.

e) The capacity range of the projects is within the applicable capacity range from 52.5 MW to 157.5 MW.

f) The start date of the concerned project activity is 28-June-2016. Therefore projects, which have started commercial operation before 28-June-2016, have been considered for analysis.

Numbers of Similar projects identified, which fulfil above-mentioned conditioned are

$$N_{\text{solar}} = 0$$

Step (3): Within the projects identified in Step 2, identify those that are neither registered CDM project activities, project activities submitted for registration, nor project activities undergoing validation. Note their number N_{all} .

CDM project activities, which have got registered or are under validation have been excluded in this step. The list of the power plants identified is provided to the DOE. After excluding the registered and under validation projects the total number of projects.

$$N_{\text{all}} = 0$$

Step (4): Within similar projects identified in Step 3, identify those that apply technologies that are different to the technology applied in the proposed project activity. Note their number N_{diff} .

As per the tool on Common Practice, the project activities have been separated from the different technologies on the basis two criteria:

1. Size of Installation – Since project activity is large scale project, small and micro scale projects are considered as different technology project. Based on this criteria, there are no any different technology project out of similar identified projects.

2. Investment climate on the date of the investment decision – The solar projects developed under different phases and different batches of National Solar Mission (NSM) can considered as different technology projects. For proposed project activity, there are no any different technology project considered out of similar identified projects.

Hence, projects where either of the conditions is satisfied those projects are counted for calculating N_{diff} projects.

$$N_{\text{diff}} = 0$$

Step (5): Calculate factor $F=1-N_{\text{diff}}/N_{\text{all}}$ representing the share of similar projects (penetration rate of the measure/technology) using a measure/technology similar to the measure/technology used in the proposed project activity that deliver the same output or capacity as the proposed project activity.

$$\begin{aligned} \text{Calculate } F &= 1 - N_{\text{diff}}/N_{\text{all}} \\ F &= 1 - (0/0) = 1 \end{aligned}$$

As per methodological tool “common practise” version 03.1, the proposed project activity is a “common practice” within a sector in the applicable geographical area if the factor F is greater than 0.2 and $N_{all} - N_{diff}$ is greater than 3.

Thus if both conditions are fulfilled, then project activity will be a common practise otherwise, the project activity is treated as not a common practise.

Outcome of Common Practise analysis:

As,

- i. $F = 1$; is greater than 0.2
- ii. $N_{all} - N_{diff} = 0$; is not greater than 3

The project activity does not satisfy second condition. Hence, project activity is not a common practice.

Thus, the proposed project activity is not a “common practice” within a sector in the applicable geographical area.

The above discussions show that solar power development is not a common practice and the project activity is not financially attractive; hence the project activity is additional.

2.6 Methodology Deviations

There is no methodology deviation.

3 ESTIMATED GHG EMISSION REDUCTIONS AND REMOVALS

3.1 Baseline Emissions

As per the approved consolidated Methodology ACM0002 (Version 18.1) para 44:

Baseline emissions include only CO₂ emissions from electricity generation in fossil fuel fired power plants that are displaced due to the project activity. The methodology assumes that all project electricity generation above baseline levels would have been generated by existing grid-connected power plants and the addition of new grid- connected power plants. The baseline emissions are to be calculated as follows:

$$BE_y = EG_{PJ,y} \times EF_{grid,CM,y}$$

Where:

BE_y = Baseline emissions in year y (t CO₂/yr)

$EG_{PJ,y}$ = Quantity of net electricity generation that is produced and fed into the grid as a result of the implementation of the CDM project activity in year y (MWh/yr)

$EF_{grid,CM,y}$ = Combined margin CO₂ emission factor for grid connected power generation in year y calculated using the latest version of the “Tool to calculate the emission factor for an electricity system” (t CO₂/MWh)

As per methodology, combined grid emission factor as per the “Tool to calculate the emission factor for an electricity system” version 06 is calculated as below.

CO₂ Baseline Database for the Indian Power Sector, Version 12, May 2017¹⁷ published by Central Electricity Authority (CEA), Government of India has been used for the calculation of emission reduction.

As per Methodological tool: Tool to calculate the emission factor for an electricity system (Version 06.0, EB 97, Annex 7), following six steps have been followed:

- (a) **Step 1:** Identify the relevant electricity systems;
- (b) **Step 2:** Choose whether to include off-grid power plants in the project electricity system (optional);
- (c) **Step 3:** Select a method to determine the operating margin (OM);
- (d) **Step 4:** Calculate the operating margin emission factor according to the selected method;
- (e) **Step 5:** Calculate the build margin (BM) emission factor;
- (f) **Step 6:** Calculate the combined margin (CM) emission factor.

Step 1: Identify the relevant electricity systems

As described in tool “For determining the electricity emission factors, identify the relevant project electricity system. Similarly, identify any connected electricity systems”. It also states that “If the DNA of the host country has published a delineation of the project electricity system and connected electricity systems, these delineations should be used”. Keeping this into consideration, the Central Electricity Authority (CEA), Government of India has divided the Indian Power Sector into five regional grids viz. Northern, Eastern, Western, North-eastern and Southern.

However since August 2006, however, all regional grids except the Southern Grid had been integrated and were operating in synchronous mode, i.e. at same frequency. Consequently, the Northern, Eastern, Western and North-Eastern grids were treated as a single grid named as NEWNE grid from FY 2007-08 onwards for the purpose of this CO₂ Baseline Database. As of 31 December 2013, the Southern grid has also been synchronised with the NEWNE grid, hence forming one unified Indian Grid. Since the project supplies electricity to the Indian grid, emissions generated due to the electricity generated by the Indian grid as per CM calculations will serve as the baseline for this project.

Table: Geographical Scope of Indian Electricity Grid

Northern	Eastern	Western	North-Eastern	Southern
Chandigarh	Bihar	Chhattisgarh	Arunachal Pradesh	Andhra Pradesh
Delhi	Jharkhand	Gujarat	Assam	Karnataka
Haryana	Orissa	Daman & Diu	Manipur	Kerala
Himachal Pradesh	West Bengal	Dadar & Nagar Haveli	Meghalaya	Tamil Nadu
Jammu & Kashmir	Sikkim	Madhya Pradesh	Mizoram	Telangana
Punjab	Andaman &	Maharashtra	Nagaland	Puducherry

¹⁷ http://www.cea.nic.in/reports/others/thermal/tpece/cdm_co2/user_guide_ver12.pdf

	Nicobar			
Rajasthan		Goa	Tripura	Lakshadweep
Uttar Pradesh				
Uttarakhand				

Step 2: Choose whether to include off-grid power plants in the project electricity system (optional)

Project participants may choose between the following two options to calculate the operating margin and build margin emission factor:

Option I: Only grid power plants are included in the calculation.

Option II: Both grid power plants and off-grid power plants are included in the calculation.

The Project Participant has chosen only grid power plants in the calculation.

Step 3: Select a method to determine the operating margin (OM)

The calculation of the operating margin emission factor ($EF_{grid,OM,y}$) is based on one of the following methods, which are described under Step 4:

- (a) Simple OM; or
- (b) Simple adjusted OM; or
- (c) Dispatch data analysis OM; or
- (d) Average OM.

The data required to calculate Simple adjusted OM and Dispatch data analysis OM is not possible due to lack of availability of data to project developers. The choice of other two options for calculating operating margin emission factor depends on generation of electricity from low-cost/must-run sources. In the context of the methodology low cost/must run resources typically include hydro, geothermal, wind, low cost biomass, nuclear and solar generation.

Share of Must-Run (Hydro/Nuclear) (% of Net Generation)

	2011-12	2012-13	2013-14	2014-15	2015-16
India	19.6%	16.9%	18.6%	16.8%	15.1%

Data Source: Central Electricity Authority (CEA) database Version 12, May 2017¹⁸

The above data clearly shows that the percentage of total grid generation by low-cost/ must-run plants (on the basis of average of five most recent years) for the Indian grid is less than 50 % of the total generation. Thus the Average OM method cannot be applied, as low cost/must run resources constitute less than 50% of total grid generation.

The simple OM emission factor is calculated as the generation-weighted average CO₂ emissions per unit net electricity generation (tCO₂/MWh) of all generating power plants serving the system, not including low-cost/must-run power plants/units.

For the simple OM, the simple adjusted OM and the average OM, the emissions factor can be calculated using either of the two following data vintages:

¹⁸ http://www.cea.nic.in/reports/others/thermal/tpece/cdm_co2/user_guide_ver12.pdf

- (a) **Ex-ante option:** if the ex-ante option is chosen, the emission factor is determined once at the validation stage, thus no monitoring and recalculation of the emissions factor during the crediting period is required.

OR

- (b) **Ex-post option:** if the ex-post option is chosen, the emission factor is determined for the year in which the project activity displaces grid electricity, requiring the emissions factor to be updated annually during monitoring.

PP has chosen ex-ante option for calculation of Simple OM emission factor using a 3-year generation-weighted average, based on the most recent data available at the time of submission of the PD to the DOE for validation.

OM determined at validation stage will be the same throughout the crediting period. There will be no requirement to monitor & recalculate the emission factor during the crediting period.

Step 4: Calculate the operating margin emission factor ($EF_{grid,OMSimple,y}$) according to the selected method

The operating margin emission factor has been calculated using a 3 year data vintage:

Net Generation in Operating Margin (GWh) (incl. Imports)			
	2013-14	2014-15	2015-16
INDIAN Grid	7,25,037	8,10,011	8,71,740

Simple Operating Margin (tCO ₂ /MWh) (incl. Imports)			
	2013-14	2014-15	2015-16
INDIAN Grid	1.00	0.99	0.96

Weighted Generation Operating Margin	
INDIAN Grid	0.9843

Step 5: Calculate the build margin (BM) emission factor ($EF_{grid,BM,y}$)

As per Methodological tool: “Tool to calculate the emission factor for an electricity system” (Version 06.0, EB 97, Annex 7) para 70:

In terms of vintage of data, project participants can choose between one of the following two options:

- (a) **Option 1** - for the first crediting period, calculate the build margin emission factor ex ante based on the most recent information available on units already built for sample group m at the time of PD submission to the DOE for validation. For the second crediting period, the build margin emission factor should be updated based on the most recent information available on units already built at the time of submission of the request for renewal of the crediting period to the DOE. For the third crediting period, the build margin emission factor calculated for the second crediting period should be used. This option does not require monitoring the emission factor during the crediting period.

- (b) **Option 2** - For the first crediting period, the build margin emission factor shall be updated annually, ex post, including those units built up to the year of registration of the project activity or, if information up to the year of registration is not yet available, including those units built up to the latest year for which information is available. For the second crediting period, the build margin

emissions factor shall be calculated ex ante, as described in Option 1 above. For the third crediting period, the build margin emission factor calculated for the second crediting period should be used.

Option 1 as described above is chosen by PP to calculate the build margin emission factor for the project activity. BM is calculated ex-ante based on the most recent information available at the time of submission of PD and is fixed for the entire crediting period.

Build Margin (tCO₂/MWh) (not adjusted for imports)	
	2015-16
INDIAN Grid	0.9083

Step 6: Calculate the combined margin (CM) emission factor (EF_{grid,CM,y})

As per Methodological tool: “Tool to calculate the emission factor for an electricity system” (Version 06.0, EB 97, Annex 7) para 79:

The calculation of the combined margin (CM) emission factor (EF_{grid,CM,y}) is based on one of the following methods:

- (a) Weighted average CM; or
- (b) Simplified CM.

PP has chosen option (a) i.e weighted average CM to calculate the combined margin emission factor for the project activity.

The combined margin emissions factor is calculated as follows:

$$EF_{grid,CM,y} = EF_{grid,OM,y} * W_{OM} + EF_{grid,BM,y} * W_{BM}$$

Where:

- EF_{grid,BM,y} = Build margin CO₂ emission factor in year y (t CO₂/MWh)
- EF_{grid,OM,y} = Operating margin CO₂ emission factor in year y (t CO₂/MWh)
- W_{OM} = Weighting of operating margin emissions factor (per cent)
- W_{BM} = Weighting of build margin emissions factor (per cent)

The following default values should be used for W_{OM} and W_{BM}:

Wind and solar power generation project activities: W_{OM} = 0.75 and W_{BM} = 0.25 (owing to their intermittent and non-dispatchable nature) for the first crediting period and for subsequent crediting periods. Since project activity is of solar power generation, the above weightage has been considered for OM and BM.

Therefore, EF_{grid,CM,y} = 0.9843 * 0.75 + 0.9083 * 0.25
 = 0.9653 t CO₂/MWh

Baseline emission factor (EF_y):

The baseline emission factor is calculated using the combined margin approach as described in Step 6 above:

Therefore, EF_y = EF_{grid,CM,y} = 0.9653 t CO₂/MWh.

BE_y = 169,781 x 0.9653 = 163,888 tCO₂

3.2 Project Emissions

As per the approved consolidated Methodology ACM0002 (Version 18.1) para 36: “For most renewable energy power generation project activities, $PE_y = 0$. However, some project activities may involve project emissions that can be significant. These emissions shall be accounted for as project emissions by using the following equation:

$$PE_y = PE_{FF,y} + PE_{GP,y} + PE_{HP,y}$$

Where:

PE_y = Project emissions in year y (t CO₂e/yr)

$PE_{FF,y}$ = Project emissions from fossil fuel consumption in year y (t CO₂/yr)

$PE_{GP,y}$ = Project emissions from the operation of dry, flash steam or binary geothermal power plants in year y (t CO₂e/yr)

$PE_{HP,y}$ = Project emissions from water reservoirs of hydro power plants in year y (t CO₂e/yr)

As the project activity is the installation of a new grid-connected Solar PV Power plant and does not involve any project emissions from fossil fuel, operation of dry, flash steam or binary geothermal power plants, and from water reservoirs of hydro power plants. Therefore $PE_{FF,y}$, $PE_{GP,y}$, $PE_{HP,y}$ are equal to zero and thus, $PE_y = 0$.

3.3 Leakage

No other leakage emissions are considered. The emissions potentially arising due to activities such as power plant construction and upstream emissions from fossil fuel use (e.g. extraction, processing, transport etc.) are neglected.

3.4 Estimated Net GHG Emission Reductions and Removals

Reductions are calculated as follows:

$$ER_y = BE_y - PE_y$$

Where:

ER_y	=	Emission reductions in year y (t CO ₂ e/yr)
BE_y	=	Baseline emissions in year y (t CO ₂ /yr)
PE_y	=	Project emissions in year y (t CO ₂ e/yr)

Therefore, Net GHG Emission Reductions and Removals are calculated as follows:

$$ER_y = BE_y - PE_y$$

Year	Estimated baseline emissions or removals	Estimated project emissions or removals	Estimated leakage emissions (tCO ₂ e)	Estimated net GHG emission reductions or removals
------	--	---	--	---

	(tCO ₂ e)	(tCO ₂ e)		(tCO ₂ e)
Year 1	126,944	0	0	126,944
Year 2	167,993	0	0	167,993
Year 3	167,993	0	0	167,993
Year 4	167,993	0	0	167,993
Year 5	167,993	0	0	167,993
Year 6	167,993	0	0	167,993
Year 7	167,993	0	0	167,993
Year 8	167,993	0	0	167,993
Year 9	167,993	0	0	167,993
Year 10	167,993	0	0	167,993
Total	1,638,881	0	0	1,638,881

4 MONITORING

4.1 Data and Parameters Available at Validation

Data / Parameter	EF_{grid,OM,y}
Data unit	tCO ₂ /MWh
Description	Operating Margin CO ₂ emission factor in year y
Source of data	Calculated from CEA database, Version 12, May 2017 ¹⁹
Value applied	0.9843
Justification of choice of data or description of measurement methods and procedures applied	Calculated as per “Tool to calculate the emission factor for an electricity system, version 05” as 3-year generation weighted average using data for the years 2013-14, 2014-15 & 2015-16. The data are obtained from “CO ₂ Baseline Database for Indian Power Sector” version 12, published by the Central Electricity Authority, Ministry of Power, Government of India.
Purpose of Data	For the calculation of the Baseline Emission
Comments	This parameter is fixed ex-ante for the entire crediting period.

Data / Parameter	EF_{grid,BM,y}
Data unit	tCO ₂ /MWh
Description	Build Margin CO ₂ emission factor in year y
Source of data	Calculated from CEA database, Version 12, May 2017 ¹⁹
Value applied	0.9083

¹⁹ http://www.cea.nic.in/reports/others/thermal/tpece/cdm_co2/user_guide_ver12.pdf

Justification of choice of data or description of measurement methods and procedures applied	Calculated as per “Tool to calculate the emission factor for an electricity system, version 05” as per the latest data available for the most recent year 2015-16. The data is obtained from “CO ₂ Baseline Database for Indian Power Sector” version 12, published by the Central Electricity Authority, Ministry of Power, Government of India.
Purpose of Data	For the calculation of the Baseline Emission
Comments	This parameter is fixed ex-ante for the entire crediting period.

Data / Parameter	$EF_{grid,CM,y}$
Data unit	tCO ₂ /MWh
Description	Combined Margin CO ₂ emission factor in year y
Source of data	Calculated from CEA database, Version 12, May 2017 ¹⁹
Value applied	0.9653
Justification of choice of data or description of measurement methods and procedures applied	<p>The combined margin emissions factor is calculated as follows:</p> $EF_{grid,CM,y} = EF_{grid,OM,y} * W_{OM} + EF_{grid,BM,y} * W_{BM}$ <p>Where:</p> <p>EF_{grid,BM,y}= Build margin CO₂ emission factor in year y (tCO₂/MWh) EF_{grid,OM,y}= Operating margin CO₂ emission factor in year y (tCO₂/MWh) W_{OM} = Weighting of operating margin emissions factor (%) = 75% W_{BM}= Weighting of build margin emissions factor (%) = 25%</p>
Purpose of Data	For the calculation of the Baseline Emission
Comments	This parameter is fixed ex-ante for the entire crediting period.

4.2 Data and Parameters Monitored

Data / Parameter	$EG_{PJ,y}$
Data unit	MWh/y
Description	Quantity of net electricity generation supplied by the project plant/unit to the grid in year y in MWh (This value will be the sum of the net electricity generated from all 3 sites)
Source of data	Monthly joint meter reading reports
Description of measurement methods and procedures to be applied	The difference of final value of export and import is used for monthly values of net electricity supplied to the grid by the project activity and same value will be considered for ER calculations.
Frequency of monitoring/recording	Continuous measurement & monthly recording

Value applied	169,781 (estimated)
Monitoring equipment	The electricity exported / supplied by the plant to pooling substation and further to substation. This meter also measures electricity imported by the plant from the grid.
QA/QC procedures to be applied	<p>The meters is approved, tested & sealed by the State Utility. The meters are in the custody of State Utility. The frequency of calibration is once in 5 years.²⁰ The monthly electricity supplied/exported by the project activity in the JMR report is cross checked with the monthly invoices of sale. In the absence or delay in the meter calibration appropriate Guidelines will be applied appropriately to confirm the conservativeness of metering.</p> <p>The metering arrangement, accuracy class of meters, calibration frequency is under control of state electricity board and PP do not have any control on it. PP is getting value of net electricity supplied to grid and the same is considered the monitoring parameter.</p> <p>The billing is raised based on substation meters.</p>
Purpose of data	Calculation of baseline emissions
Calculation method	Thus, Net electricity supplied to the grid by the project plant in a given month = Export, kWh– Import, kWh
Comments	Data will be archived in paper & electronic form for two years after the end of crediting period or of the last issuance of VERs for this project activity, whichever occurs later.

4.3 Monitoring Plan

The monitoring plan is developed in accordance with the modalities and procedures for CDM project activities and is proposed for grid-connected solar power project being implemented. The monitoring plan, which will be implemented by the project participant describes about the monitoring organisation, parameters to be monitored, monitoring practices, quality assurance, quality control procedures, data storage and archiving.

The authority and responsibility for registration, monitoring, measurement, reporting and reviewing of the data rests with the project participant. PP proposed the following structure for data monitoring, collection, data archiving and calibration of equipments for this project activity. The team comprises of the following members:

²⁰ http://www.aegcl.co.in/Metering_Regulations_Of_CEA_17_03_2006.pdf

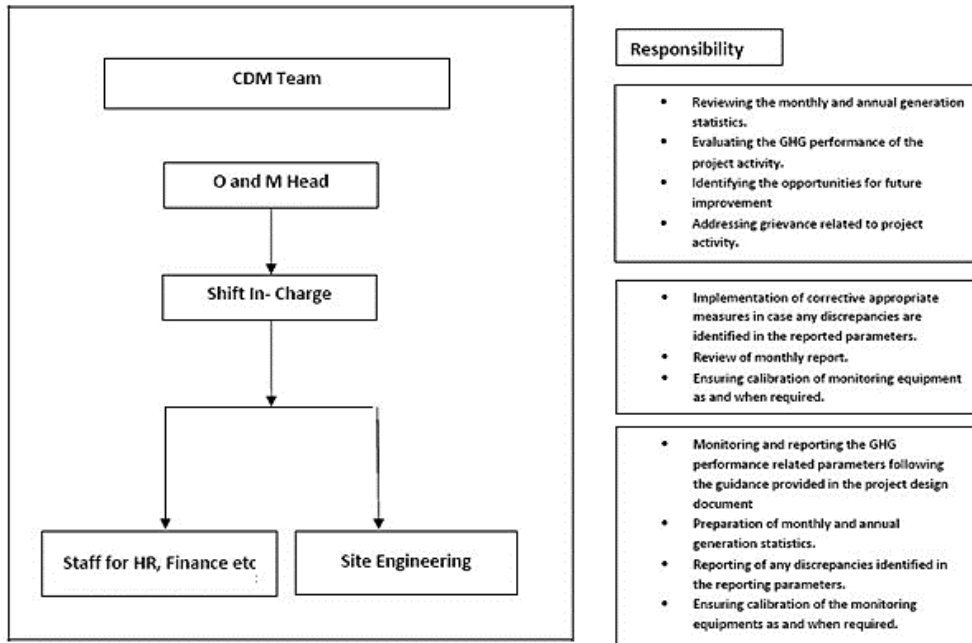

Data Measurement

The export and import energy will be measured continuously using above mentioned Main and Check meters located at the substations. Readings of meters shall be taken on monthly basis by authorized officer of SEB in the presence of PP or representative of PP. Based on the Meter Reading Statement to PP, invoices will be raised. These invoices can be used for cross checking the meter readings taken for the respective project activity.

Data collection and archiving

Readings from meters will be collected in the presence of the plant in-charge. Export and Import data would be recorded and stored in logs as well as in electronic form on a daily basis. The records are checked periodically by the Plant Manager and discussed thoroughly with the plant supervisor. The period of storage of the monitored data will be 2 years after the end of crediting period or till the last issuance of VERs for the project activity whichever occurs later.

Emergency preparedness

The project activity will not result in any unidentified activity that can result in substantial emissions from the project activity. No need for emergency preparedness in data monitoring is visualized.

Personnel training

In order to ensure a proper functioning of the project activity and a properly monitoring of emission reductions, the staff will be trained. The plant helpers will be trained in equipment operation, data recording, reports writing, operation and maintenance and emergency procedures in compliance with the monitoring plan.

Metering Arrangement

Line diagram with metering arrangement for the project activity is shown below.

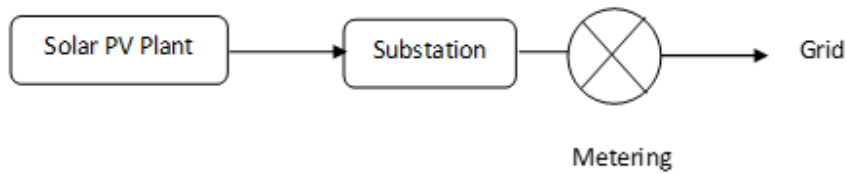

The metering arrangement for all the three sites are the same. Each solar plant has their own dedicated metering arrangement at the substation end. The metering arrangement is under control of state electricity board and may change in future.

5 SAFEGUARDS

5.1 No Net Harm

The project activity does not involve any major construction activity. It primarily requires the installation of the solar PV panels, interfacing the generators with the State Electricity Board by setting up HT transmission lines and installation of other accessories.

The report on “Developmental Impacts and Sustainable Governance Aspects of Renewable Energy Projects” prepared by MNRE dated September 2013. This report clearly mentioned that solar PV project activity operations do not result in direct air pollution, noise pollution. Please refer below web link for the same²¹.

Thus there are no any significant impacts due to implementation of project activity on air, water, soil quality and ambience are envisaged due to the project activity.

5.2 Environmental Impact

The project activity has no significant impact on the environment. Solar PV projects are not included in the Schedule I of the EIA notification S.O.1533 (E) dated 14th September 2006²² and thus an EIA is not required. Ministry of Environment & forests vide their OM J-11013/41/2006 - IA II (I) dated 13th May 2011²³ has re-affirmed this and exempted Solar PV power plants from EIA and EC requirement.

5.3 Local Stakeholder Consultation

The details of the Stakeholder Meetings are as follows:

1. For 15 MW Solar Project at Telangana by Winsol Solar Fields (Polepally) Pvt Ltd

Date of invitation – 05/01/2016

Date of Meeting – 12/01/2016

²¹ <http://mnre.gov.in/file-manager/UserFiles/report-on-developmental-impacts-of-RE.pdf>

²² <http://envfor.nic.in/legis/eia/so1533.pdf>

²³ <http://moef.nic.in/downloads/public-information/OM-SolarPV.pdf>

Location of Meeting - Project site, Telangana

2. For 50 MW Solar Project at Telangana by Winsol Solar Fields (Polepally) Pvt Ltd

Date of invitation – 06/01/2016

Date of Meeting – 13/01/2016

Location of Meeting - Project site, Telangana

3. For 40 MW Solar Project at Andhra Pradesh by Hindupur Solar Park Pvt Ltd

Date of invitation – 07/01/2016

Date of Meeting – 14/01/2016

Location of Meeting - Project site, Andhra Pradesh

In the introductory speech, the representative of Vector Green Energy Private Limited (Project Investor), welcomed the gathering and given a brief about the climate mitigation project activity. Subsequent to the introductory speech, stakeholders were explained about the electricity generation from solar project is an environmental friendly power generation technology contributing to reduction in GHG emissions. They were also explained about the benefits of the solar power projects like, increasing energy availability and improving quality of power and its assistance to the local population by providing employment opportunities to both skilled & unskilled labours.

The Minutes of meeting with commenting sheet from LSH, invitation letter receipt copy are submitted to the DOE.

Meeting started with opening speech by representative of project participant. He introduced all guests on dais. The representative of project participant explained Technical aspects of project to stakeholders. He also explained about social, environmental & economical benefits of the project. He also elaborated about carbon mechanism & its requirement for the current project. After the detailed discussions, the session was open for questions from stakeholders.

Most of the questions were related to employment opportunities, economic development, benefits from project to villagers and other development activities. The question raised by the villagers are summarised below:

Q: Does the project provides employment opportunities or improve economic development of the area?

A: Yes, the project will provide economic development of the area and will provide employment opportunities to the local people depending upon their skill and qualification.

Q: Will the operation of the plant result in increased temperature in the surroundings?

A: There will be no impact on ambient temperature due to operation of the plant.

Q: How the project activity benefit the villages around the project site and their residents?

A: The project activity will benefit the nearby villagers by providing employment opportunities to local or nearby people and also provides immense opportunity for economic development of the area like increase in business opportunities in the form of works for module cleaning, hiring of vehicle etc., improvement in transportation; and various social activities shall help to uplift the standard of living.

5.4 Public Comments

The project was open for Public Comments from 18-June-2018 to 18-July-2018. No comments were received during this period.

6 ACHIEVED GHG EMISSION REDUCTIONS AND REMOVALS

6.1 Data and Parameters Monitored

Data / Parameter	$EG_{PJ,y}$
Data unit	MWh/y
Description	Quantity of net electricity generation supplied by the project plant/unit to the grid in year y in MWh. (This value is the sum of the net electricity generated from all 3 sites)
Value applied:	321,387 MWh
Comments	Data will be archived in paper & electronic form for two years after the end of crediting period or of the last issuance of VERs for this project activity, whichever occurs later.

6.2 Baseline Emissions

$$BE_y = EG_{PJ,y} * EF_{grid,CM,y}$$

Where:

BE_y : Baseline emissions in year y (tCO₂e/yr)

$EG_{PJ,y}$: Quantity of net electricity generation that is produced and fed into the grid as a result of the implementation of the VCS project activity in year y (MWh/yr)

$EF_{grid,CM,y}$: Combined margin CO₂ emission factor for grid connected power generation in year y calculated using the latest version of the “Tool to calculate the emission factor for an electricity system” (tCO₂e/MWh)

Parameter	Unit	Value
$EG_{PJ,y}$	MWh	321,387
$EF_{grid,CM,y}$	tCO ₂ e	0.9653
BE_y	=	321,387 * 0.9653

	=	310,233 (Round down value)
--	---	----------------------------

6.3 Project Emissions

Not Applicable, since emissions from the project activity is zero as per ACM0002 methodology.

6.4 Leakage

Not Applicable, since leakage emissions from the project activity is zero as per ACM0002 methodology.

6.5 Net GHG Emission Reductions and Removals

Year	Baseline emissions or removals (tCO ₂ e)	Project emissions or removals (tCO ₂ e)	Leakage emissions (tCO ₂ e)	Net GHG emission reductions or removals (tCO ₂ e)
2016	48,772	0	0	48,772
2017	144,776	0	0	144,776
2018	116,685	0	0	116,685
Total	310,233	0	0	310,233

It is to be noted here that as per the estimated emission reduction to be achieved from the project activity for the current monitoring period is 277,908 tCO₂e, whereas actual emission reductions achieved are 310,233 tCO₂e, which is approximately 12% higher than the estimated emission reductions. The generation of electricity depends upon the number of annual days of sunshine availability and many other climatic conditions, and not within the control of the project participant. The higher generation during the current verification period is hence due to certain natural conditions and hence acceptable. Also there is no any adverse impact on additionality due to high PLF achieved during current monitoring period.

Appendix 1: Input Parameters and Assumptions for Additionality Assessment

1. Assumptions and Values considered for Financial and Sensitivity Analysis for 15 MW Solar Project by Winsol Solar Fields (Polepally) Pvt Ltd

Details of the project		Source
State where the project is situated	Telangana	As per DPR
Total Capacity (MW)	15.00	As per DPR
Expected Date of Commissioning	30-Jun-16	As per offer letter
Life of the plant (Yrs.)	25	As per DPR
Generation of electricity		
PLF (%)	19.14%	As per DPR
Annual generation (kWh)	25,149,960	Calculated Value
Annual Degradation per year	0.50%	As per DPR
Tariff rate at the decision making (INR/kWh)	6.45	As per DPR
Escalation in tariff rate	0.0%	
Transmission & Wheeling Losses (%)	0.00%	
Operation and maintenance cost and Insurance		
O & M Expenses (INR Mn.)	18.00	As per DPR
O & M free for (Yr.)	-	
Escalation in the operational expenses (%)	5.00%	As per DPR
Insurance (INR Mn.)	13.14	CERC order ²⁴
Administrative Expenses	3.00	
Financial parameters		
Total Cost (INR Mn.)	1,314.00	As Per DPR
Loan Amount (INR Mn.)	919.80	As Per DPR
Equity Investment (INR Mn.)	394.20	As Per DPR
Term loan		
Loan Amount (INR Mn.)	919.80	As Per DPR
Interest rate (%)	11.25%	As Per DPR
Loan Tenure (Qtr.)	48	Assumption
Moratorium Period (Qtr.)	-	Assumption
Repayment Period (Qtr.)	48	Calculated Value
Repayment instalments value (INR Mn.)	19.163	Calculated Value
1st instalment from (Qtr. end)	30-Sep-16	Considered from the next Quarter End
Book Depreciation (SLM Method)		
Land	-	

²⁴ <http://www.cercind.gov.in/2016/orders/SO17.pdf>

Gross Depreciable Value (INR Mn.)	1,314.00	Calculated Value
Salvage Value (%)	10.00%	
Salvage value (INR Mn.)	131.40	Calculated Value
Net Depreciable Value (INR Mn.)	1,182.60	Calculated Value
Residual Value (INR Mn.)	131.40	Calculated Value
IT Depreciation		
IT Depreciation(%)	80.00%	IT act ²⁵
Income Tax		
Financial Year	FY 2016-17	
Income tax rate (%)	30.00%	As Per DPR
MAT (%)	18.50%	As Per DPR
Service Tax (%)	15.00%	As Per Income Tax Rule ²⁶
Surcharge (%)	12.00%	As Per DPR
Education cess (%)	3.00%	As Per DPR
Final Tax rates		
Income tax rate (%)	34.61%	Calculated Value
MAT (%)	21.34%	Calculated Value
Service Tax (%)	15.45%	Calculated Value

Sensitivity Analysis

Sensitivity Analysis	Equity IRR				
	Variation %	-10%	Normal	10%	Breaching Value
PLF		4.19%	7.39%	11.07%	19.93%
O&M		7.99%	7.39%	6.78%	-125.38%
Project Cost		10.65%	7.39%	5.08%	-19.49%
Tariff Rate		4.19%	7.39%	11.07%	19.93%

Final Result

Equity IRR without CDM	Benchmark (Equity IRR)
7.39%	15.10%

²⁵ http://www.taxafin.com/Income_Tax/Tax_Rates/Depreciation_Rates.html

²⁶ <http://taxguru.in/service-tax/service-tax-rate-chart-effect-01062016.html>

2. Assumptions and Values considered for Financial and Sensitivity Analysis for 50 MW Solar Project by Winsol Solar Fields (Polepally) Pvt Ltd

Details of the project		Source
State where the project is situated	Telangana	As per DPR
Total Capacity (MW)	50.00	As per DPR
Expected Date of Commissioning	30-Jun-16	As per offer letter
Life of the plant (Yrs.)	25	As per DPR
Generation of electricity		
PLF (%)	18.96%	As per DPR
Annual generation (kWh)	83,044,800	Calculated Value
Annual Degradation per year	0.50%	As per DPR
Tariff rate at the decision making (INR/kWh)	6.45	As per DPR
Escalation in tariff rate	0.0%	
Transmission & Wheeling Losses (%)	0.00%	
Operation and maintenance cost and Insurance		
O & M Expenses (INR Mn.)	60.00	As per DPR
O & M free for (Yr.)	-	
Escalation in the operational expenses (%)	5.00%	As per DPR
Insurance (INR Mn.)	41.32	CERC order ²⁷
Administrative Expenses	10.00	
Financial parameters		
Total Cost (INR Mn.)	4,132.00	As Per DPR
Loan Amount (INR Mn.)	2,892.40	As Per DPR
Equity Investment (INR Mn.)	1,239.60	As Per DPR
Term loan		
Loan Amount (INR Mn.)	2,892.40	As Per DPR
Interest rate (%)	11.25%	As Per DPR
Loan Tenure (Qtr.)	48	Assumption
Moratorium Period (Qtr.)	-	Assumption
Repayment Period (Qtr.)	48	Calculated Value
Repayment instalments value (INR Mn.)	60.258	Calculated Value
1st instalment from (Qtr. end)	30-Sep-16	Considered from the next Quarter End
Book Depreciation (SLM Method)		
Land	-	
Gross Depreciable Value (INR Mn.)	4,132.00	Calculated Value
Salvage Value (%)	10.00%	

²⁷ <http://www.cercind.gov.in/2016/orders/SO17.pdf>

Salvage value (INR Mn.)	413.20	Calculated Value
Net Depreciable Value (INR Mn.)	3,718.80	Calculated Value
Residual Value (INR Mn.)	413.20	Calculated Value
IT Depreciation		
IT Depreciation(%)	80.00%	IT act ²⁸
Income Tax		
Financial Year	FY 2016-17	
Income tax rate (%)	30.00%	As Per DPR
MAT (%)	18.50%	As Per DPR
Service Tax (%)	15.00%	As Per Income Tax Rule ²⁹
Surcharge (%)	12.00%	As Per DPR
Education cess (%)	3.00%	As Per DPR
Final Tax rates		
Income tax rate (%)	34.61%	Calculated Value
MAT (%)	21.34%	Calculated Value
Service Tax (%)	15.45%	Calculated Value

Sensitivity Analysis

Sensitivity Analysis	Equity IRR				
	Variation %	-10%	Normal	10%	Breaching Value
PLF		5.20%	8.69%	12.48%	15.22%
O&M		9.35%	8.69%	8.03%	-94.97%
Project Cost		12.40%	8.69%	6.15%	-15.63%
Tariff Rate		5.20%	8.69%	12.48%	15.22%

Final Result

Equity IRR without CDM	Benchmark (Equity IRR)
8.69%	15.10%

²⁸ http://www.taxafin.com/Income_Tax/Tax_Rates/Depreciation_Rates.html

²⁹ <http://taxguru.in/service-tax/service-tax-rate-chart-effect-01062016.html>

3. Assumptions and Values considered for Financial and Sensitivity Analysis for 40 MW Solar Project by Hindupur Solar Park Pvt Ltd

Details of the project		Source
State where the project is situated	Andhra Pradesh	As per DPR
Total Capacity (MW)	40.00	As per DPR
Expected Date of Commissioning	30-Jun-16	As per offer letter
Life of the plant (Yrs.)	25	As per DPR
Generation of electricity		
PLF (%)	18.79%	As per DPR
Annual generation (kWh)	65,840,160	Calculated Value
Annual Degradation per year	0.50%	As per DPR
Tariff rate at the decision making (INR/kWh)	5.35	As per DPR
Escalation in tariff rate	0.0%	
Transmission & Wheeling Losses (%)	0.00%	
Operation and maintenance cost and Insurance		
O & M Expenses (INR Mn.)	48.00	As per DPR
O & M free for (Yr.)	-	
Escalation in the operational expenses (%)	5.00%	As per DPR
Insurance (INR Mn.)	28.70	CERC order ³⁰
Administrative Expenses	8.00	
Financial parameters		
Total Cost (INR Mn.)	2,870.00	As Per DPR
Loan Amount (INR Mn.)	2,009.00	As Per DPR
Equity Investment (INR Mn.)	861.00	As Per DPR
Term loan		
Loan Amount (INR Mn.)	2,009.00	As Per DPR
Interest rate (%)	11.25%	As Per DPR
Loan Tenure (Qtr.)	48	Assumption
Moratorium Period (Qtr.)	-	Assumption
Repayment Period (Qtr.)	48	Calculated Value
Repayment instalments value (INR Mn.)	41.854	Calculated Value
1st instalment from (Qtr. end)	30-Sep-16	Considered from the next Quarter End
Book Depreciation (SLM Method)		
Land	-	
Gross Depreciable Value (INR Mn.)	2,870.00	Calculated Value
Salvage Value (%)	10.00%	

³⁰ <http://www.cercind.gov.in/2016/orders/SO17.pdf>

Salvage value (INR Mn.)	287.00	Calculated Value
Net Depreciable Value (INR Mn.)	2,583.00	Calculated Value
Residual Value (INR Mn.)	287.00	Calculated Value
IT Depreciation		
IT Depreciation(%)	80.00%	IT act ³¹
Income Tax		
Financial Year	FY 2016-17	
Income tax rate (%)	30.00%	As Per DPR
MAT (%)	18.50%	As Per DPR
Service Tax (%)	15.00%	As Per Income Tax Rule ³²
Surcharge (%)	12.00%	As Per DPR
Education cess (%)	3.00%	As Per DPR
Final Tax rates		
Income tax rate (%)	34.61%	Calculated Value
MAT (%)	21.34%	Calculated Value
Service Tax (%)	15.45%	Calculated Value

Sensitivity Analysis

Sensitivity Analysis	Equity IRR				
	Variation %	-10%	Normal	10%	Breaching Value
PLF		2.51%	5.69%	9.13%	24.55%
O&M		6.45%	5.69%	4.91%	-125.90%
Project Cost		8.57%	5.69%	3.56%	-23.89%
Tariff Rate		2.51%	5.69%	9.13%	24.55%

Final Result

Equity IRR without CDM	Benchmark (Equity IRR)
5.69%	15.10%

³¹ http://www.taxafin.com/Income_Tax/Tax_Rates/Depreciation_Rates.html

³² <http://taxguru.in/service-tax/service-tax-rate-chart-effect-01062016.html>

Appendix 2: Calibration and Meter Details

Calibration and Meter Details of 15 MW solar project by Winsol Solar Fields (Polepally) Pvt Ltd

Meter Details	Main Meter	Check Meter	Standby Meter
Meter Serial No	APX00924	APX00925	APX00926
Meter Make	Secure	Secure	Secure
Accuracy Class	0.2 s	0.2 s	0.2 s
Date of Calibration ³³	31-07-2017	31-07-2017	31-07-2017

Calibration and Meter Details of 50 MW solar project by Winsol Solar Fields (Polepally) Pvt Ltd

Meter Details	Main Meter	Check Meter	Standby Meter
Meter SI. No	APW00111	AP925645	APX00645
Make	Secure	Secure	Secure
Accuracy Class	0.2 s	0.2 s	0.2 s
Date of Calibration ³⁴	02-03-2018	02-03-2018	02-03-2018

Calibration and Meter Details of 40 MW solar project by Hindupur Solar Park Pvt Ltd

Hindupur Solar Park Pvt Ltd- I			
Meter Details	Main Meter	Check Meter	Standby Meter
Meter SI. No	APX00864	APX00865	APX00866
Make	SECURE	SECURE	SECURE
Accuracy Class	0.2 s	0.2 s	0.2 s
Date of Calibration ³⁵	04-12-2017	04-12-2017	04-12-2017

³³ The calibration of the energy meter is done by the State Electricity Board and therefore, it is not in hands of the PP. At the time of commissioning, newly calibrated meters were installed by the State Electricity Board. However, the PP do not have the initial calibration reports with them. The energy meters were calibrated again on 31-07-2017. Hence, as a conservative approach, maximum permissible error factor of 0.2% has been applied to the export and import values from commissioning till July 2017.

³⁴ The calibration of the energy meter is done by the State Electricity Board and therefore, it is not in hands of the PP. At the time of commissioning, newly calibrated meters were installed by the State Electricity Board. However, the PP do not have the initial calibration reports with them. The energy meters were calibrated again on 02-03-2018. Hence, as a conservative approach, maximum permissible error factor of 0.2% has been applied to the export and import values from commissioning till March 2018.

³⁵ The calibration of the energy meter is done by the State Electricity Board and therefore, it is not in hands of the PP. At the time of commissioning, newly calibrated meters were installed by the State Electricity Board. However, the PP do not have the initial calibration reports with them. The energy meters were calibrated again on 04-12-2017. Hence, as a conservative approach, maximum permissible error factor of 0.2% has been applied to the export and import values from commissioning till Dec 2017.

Hindupur Solar Park Pvt Ltd- II			
Meter Details	Main Meter	Check Meter	Standby Meter
Meter Sl. No	APX00858	APX00859	APX00860
Make	SECURE	SECURE	SECURE
Accuracy Class	0.2 s	0.2 s	0.2 s
Date of Calibration ³⁶	21-09-2017	21-09-2017	21-09-2017

Hindupur Solar Park Pvt Ltd- III			
Meter Details	Main Meter	Check Meter	Standby Meter
Meter Sl. No	APX00861	APX00862	APX00863
Make	SECURE	SECURE	SECURE
Accuracy Class	0.2 s	0.2 s	0.2 s
Date of Calibration ³⁷	04-12-2017	04-12-2017	04-12-2017

Hindupur Solar Park Pvt Ltd- IV			
Meter Details	Main Meter	Check Meter	Standby Meter
Meter Sl. No	APX00867	APX00868	APX00869
Make	SECURE	SECURE	SECURE
Accuracy Class	0.2 s	0.2 s	0.2 s
Date of Calibration ³⁸	04-12-2017	04-12-2017	04-12-2017

³⁶ The calibration of the energy meter is done by the State Electricity Board and therefore, it is not in hands of the PP. At the time of commissioning, newly calibrated meters were installed by the State Electricity Board. However, the PP do not have the initial calibration reports with them. The energy meters were calibrated again on 21-09-2017. Hence, as a conservative approach, maximum permissible error factor of 0.2% has been applied to the export and import values from commissioning till Sep 2017.

³⁷ The calibration of the energy meter is done by the State Electricity Board and therefore, it is not in hands of the PP. At the time of commissioning, newly calibrated meters were installed by the State Electricity Board. However, the PP do not have the initial calibration reports with them. The energy meters were calibrated again on 04-12-2017. Hence, as a conservative approach, maximum permissible error factor of 0.2% has been applied to the export and import values from commissioning till Dec 2017.

³⁸ The calibration of the energy meter is done by the State Electricity Board and therefore, it is not in hands of the PP. At the time of commissioning, newly calibrated meters were installed by the State Electricity Board. However, the PP do not have the initial calibration reports with them. The energy meters were calibrated again on 04-12-2017. Hence, as a conservative approach, maximum permissible error factor of 0.2% has been applied to the export and import values from commissioning till Dec 2017.