



# Verified Carbon Standard

## DISTRIBUTION OF IMPROVED COOK STOVE – PHASE 14



South Asia

Document Prepared by  
TÜV SÜD South Asia Pvt Ltd

<b>Project Title</b>	Distribution Of Improved Cook Stove - Phase 14
<b>Report Title</b>	VCS Validation & Verification “Distribution of Improved Cook Stove - Phase 14”
<b>Version</b>	3.0
<b>Report ID</b>	10893ME (2428)
<b>Verification Period</b>	04-October-2012 to 03-October-2017 (First and Last date included)
<b>Client</b>	EKI Energy Services Limited
<b>Pages</b>	43
<b>Date of Issue</b>	16-August-2022
<b>Prepared By</b>	TÜV SÜD South Asia Pvt. Ltd,
<b>Contact</b>	4th floor, Solitaire ITI Road, Aundh Pune- 411007 India <a href="mailto:eswar.murty@tuv-sud.in">eswar.murty@tuv-sud.in</a>
<b>Approved By</b>	Milind Shende, Manager Certification Body, TÜV SÜD South Asia Pvt Ltd.
<b>Work Carried Out By</b>	Eswar Murty Team Leader, Validator, Verifier & Technical Expert (TA 3.1)

## Summary:

TÜV SÜD South Asia Pvt Ltd has performed the gap validation and verification of VCS 2428 project "Distribution of Improved Cook Stove - Phase 14". This report summarizes the findings of the gap validation and verification of this project, performed on the basis of VCS Standard Version 4.2 criteria.

The Project Participants is M/s G K Energy Marketers Pvt. Ltd .

**GAP Validation purpose:** The project activity involves the distribution of improved cook stoves as per IS13152 (Part 1): 1991 (Solid Biomass – Chulha Part 1 (Metallic)) of CPRI Design, Type I design approved by Bureau of Indian Standard. The Ministry of New and renewable Energy has approved Vikram cook stoves and Fabricators for manufacturing of the cook stoves as per the above specifications and the same stoves are distributed in this project.

This project involves distribution of improved cook stoves in tribal households (Schedule Tribe) and families living below the poverty level (BPL) and Scheduled Tribes (ST) households in rural areas of Aurangabad, Jalna, Parbhani, Hingoli, Beed, Nanded, Osmanabad, Latur, Buldhana, Akola, Washim, Amravati, Yavatmal, Wardha, Nagpur, Bhandara, Chandrapur, Gadchiroli and Gondia districts which lies in Aurangabad, Amravati and Nagpur Divisions in Maharashtra. The improved cook stoves through replacement of inefficient traditional cook stove will contribute towards reduction of greenhouse gas emission resulting in the reduction of firewood consumption leading to climate change mitigation in a sustainable manner.

The project is registered under CDM mechanism (UNFCCC reference number: 8809). The present validation (gap validation) is under VCS mechanism and assessment of clause (1.1, 1.2, 1.3, 1.5, 1.6, 1.7, 1.9, 1.10, 1.12, 1.13, 1.14, 1.15.1, 1.16, 1.17 and 3.6) of the VCS Project Description Template. The same is in line with Para 3.20 of VCS standard version 4.2.

**Verification purpose:** This project involves distribution of improved cook stoves in tribal households (Schedule Tribe) and families living below the poverty level (BPL) and Scheduled Tribes (ST) households in rural areas of Aurangabad, Jalna, Parbhani, Hingoli, Beed, Nanded, Osmanabad, Latur, Buldhana, Akola, Washim, Amravati, Yavatmal, Wardha, Nagpur, Bhandara, Chandrapur, Gadchiroli and Gondia districts which lies in Aurangabad, Amravati and Nagpur Divisions in Maharashtra. The improved cook stoves through replacement of inefficient traditional cook stove will contribute towards reduction of greenhouse gas emission resulting in the reduction of firewood consumption leading to climate change mitigation in a sustainable manner. Total 14,517 cook stoves were distributed in the project activity.

This is the first monitoring period under VCS and covers the activity from 04-October-2012 to 03-October-2017 (First and Last date included). The project is registered under Clean

Development Mechanism (CDM) of UNFCCC with 10 years fixed crediting period (Fixed) (Reference No: 8809) on 19-December-2012. The Crediting period of the project under CDM started on 30-December-2013 and will end on 29-December-2022. The date of supply/ receipt of first lot of improved cookstoves from manufacturer to the regional office of the line department was considered as start date under the CDM registered PDD (evidenced through acknowledgement of the delivery receipt of the line department) as per CDM definition of Start Date. The start date referred to in the registered CDM-PDD was mirrored in the VCS PD. Since the date does not resembles to handover of the cookstoves to beneficiary and does not result in onset of actual emission reduction therefore the same cannot be considered as start date under VCS mechanism and therefore the date of distribution/ handover of improved cookstoves to first beneficiary i.e. 04-October-2012 is taken as start date of VCS in line with VCS standard, version 4.2. and distribution completed on 16-December-2022. Thus, it is therefore the start date of crediting period is considered from 04-October- 2012. The crediting period for VCS began on 04-October-2012 to 03-October -2022.

The project proponent will not claim GHG emission reductions under two schemes for the same period. The GHG credits 04-October-2012 to 03-October-2017 (First and Last date included) will be claimed under VCS only. An undertaking from the project participant confirms that project will not claim any other scheme benefits for the concerned monitoring period.

The scope of gap validation & verification includes confirming the implementation of the monitoring plan and the application of methodology AMS II-G., Energy efficiency measures in thermal applications of non-renewable biomass, Version 03.0.

The audit team has raised 2 Corrective Action Requests (CARs) and 3 Clarification Requests (CLs) during the course of gap validation and verification process and the same have been successfully closed.

In conclusion, it is TÜV SÜD's opinion that the project activity "Distribution Of Improved Cook Stove - Phase 14", as described in the VCS PD version 02 and Monitoring Report 02 meets all relevant requirements for VCS activities for the validation and verification.

# CONTENTS

---

- 1 INTRODUCTION ..... 5**
  - 1.1 Objective ..... 5
  - 1.2 Scope and Criteria ..... 5
  - 1.3 Level of Assurance ..... 6
  - 1.4 Summary Description of the Project ..... 6
  
- 2 VALIDATION AND VERIFICATION PROCESS ..... 11**
  - 2.1 Method and Criteria ..... 11
  - 2.2 Document Review ..... 12
  - 2.3 Interviews ..... 13
  - 2.4 Site Inspections ..... 15
  - 2.5 Resolution of Findings ..... 15
  
- 3 VALIDATION FINDINGS ..... 22**
  - 3.1 Project Details ..... 22
  - 3.2 Participation under Other GHG Programs ..... 27
  - 3.3 Safeguards ..... 28
  - 3.4 Application of Methodology ..... 28
  - 3.5 Non-Permanence Risk Analysis ..... 29
  
- 4 VERIFICATION FINDINGS ..... 29**
  - 4.1 Accuracy of GHG Emission Reduction and Removal Calculations ..... 29
  - 4.2 Quality of Evidence to Determine GHG Emission Reductions and Removals ..... 40
  
- 5 VALIDATION AND VERIFICATION CONCLUSION ..... 42**

# 1 INTRODUCTION

## 1.1 Objective

TÜV SÜD has been commissioned by the aforementioned client to perform an independent validation and verification assessment

The objective of the gap validation is to have an independent evaluation of a project activity by a designated operational entity against the requirements of the VCS Version 4.2 and GHG program applied, on the basis of the project design document. In particular, the project's baseline, monitoring plan, and the project's compliance with relevant VCS requirements, GHG program requirements and host Party criteria are validated in order to confirm that the project design, as documented, is sound and reasonable and meets the identified criteria. Gap validation and verification is a requirement for all VCS projects and is seen as necessary to provide assurance to stakeholders of the quality of the project and its intended generation of Voluntary Carbon Units (VCUs).

The objective of the verification work is to comply with the requirements of Verified Carbon Standards requirements. According to this assessment TÜV SÜD shall:

- ensure that the project activity has been implemented and operated as per the VCS and CDM PDD, and that all physical features (technology, project equipment, monitoring and metering equipment) of the project are in place,
- the project's baseline is assessed against "AMS II.G - Version 03"
- the project's monitoring plan is assessed against "AMS II.G - Version 03"
- ensure that the submitted MR and other supporting documents provided are complete, verifiable and in accordance with applicable VCS and CDM VVS requirements,
- ensure that the actual monitoring systems and procedures comply with the monitoring systems and procedures described in the monitoring plan and the approved methodology,
- evaluate the data recorded and stored as per the applicable requirements.
- assessment of the sustainability monitoring parameters as per the VCS requirements

## 1.2 Scope and Criteria

The scope of any assessment is defined by the underlying legislation, regulation and guidance given by relevant entities or authorities. In the case of VCS project activities, the scope is set by:

- VCS v4.2 requirements
- Baselines and monitoring methodologies (including GHG inventories)
- Environmental issues relevant to the applicable sectoral scope
- Current technical and operational knowledge of the specific sectoral scope and information on best practice
- Stakeholder consultation and feedback

The gap validation and verification process is not meant to provide any form of consulting for the project participant (PP). However, stated requests for clarifications, corrective actions, and/or forward actions may provide input for improvement of the project design.

### 1.3 Level of Assurance

All the revisions of the validation & verification report before being submitted to the client were subjected to an independent internal technical review to confirm that all validation activities had been completed according to the pertinent TÜV SÜD's instructions.

The technical review was performed by a technical reviewer(s) qualified in accordance with TÜV SÜD's qualification scheme for VCS and CDM validation and verification.

The level of assurance of the validation report is defined as reasonable. The VVB confirms that a reasonable level of assurance has been achieved during the verification process

### 1.4 Summary Description of the Project

The project activity involves the distribution of improved cook stoves as per IS13152 (Part 1): 1991 (Solid Biomass –Chulha Part 1 (Metallic)) of CPRI Design, Type I design approved by Bureau of Indian Standard. The Ministry of New and renewable Energy has approved Vikram cook stoves and Fabricators for manufacturing of the cook stoves as per the above specifications and the same stoves are distributed in this project.

This project involves distribution of improved cook stoves in tribal households (Schedule Tribe) and families living below the poverty level (BPL) and Scheduled Tribes (ST) households in rural areas of Aurangabad, Jalna, Parbhani, Hingoli, Beed, Nanded, Osmanabad, Latur, Buldhana, Akola, Washim, Amravati, Yavatmal, Wardha, Nagpur, Bhandara, Chandrapur, Gadchiroli and Gondia districts which lies in Aurangabad, Amravati and Nagpur Divisions in Maharashtra. The improved cook stoves through

replacement of inefficient traditional cook stove will contribute towards reduction of greenhouse gas emission resulting in the reduction of firewood consumption leading to climate change mitigation in a sustainable manner.

As confirmed through the remote inspection, the technology deployed under the project activity is single pot, portable, metallic, improved biomass cook stoves made of cast iron for combustion of solid biomass, which are manufactured in accordance to IS 13152, Part-1: 1991, CPRI Design Type I standard. The cook stove has been tested for thermal efficiency of 29.88% as per water boiling test protocol specified in IS 13152, Part 1: 1991. The efficiency test report provided to assessment team was reviewed and it was concluded that the efficiency test was conducted in accordance with the procedure stipulated in the applied methodology AMS II-G., Energy efficiency measures in thermal applications of non-renewable biomass, Version 03.0.

The individual households using ICS has signed an agreement with the PP along with Vikram Stoves (Manufacturer) & entered into contractual agreement with the beneficiaries by virtue of which, the end user will confirm use of cook stove as well as transfer the CER right to the Project Participant. The sample agreement was validated by the assessment team for the cook stoves and found in line with the VCS-PD. The estimated total amount of emission reductions over the chosen 10-year "fixed crediting period" is less than 300,000 tCO<sub>2e</sub>. The estimated amount of emission reductions per annum are 13,050 tCO<sub>2e</sub>.

Validation team has checked the summary description of the project defined in the VCS PD and found consistent with the registered CDM PDD.

This is the first monitoring period under VCS and covers the activity from 04-October-2012 and will end on 03-October-2022 (First and Last date included). The project is registered under Clean Development Mechanism (CDM) of UNFCCC with 10 years fixed crediting period (Fixed) (Reference No: 8809) on 19-December-2012. The Crediting period of the project under CDM started on 30-December-2013 and will end on 29-December-2022. The date of supply/ receipt of first lot of improved cookstoves from manufacturer to the regional office of the line department was considered as start date under the CDM registered PDD (evidenced through acknowledgement of the delivery receipt of the line department) as per CDM definition of Start Date. The start date referred to in the registered CDM-PDD was mirrored in the VCS PD. Since the date does not resembles to handover of the cookstoves to beneficiary and does not result in onset of actual emission reduction therefore the same cannot be considered as start date under VCS mechanism and therefore the date of distribution/ handover

of improved cookstoves to first beneficiary i.e. 04-October-2012 is taken as start date of VCS in line with VCS standard, version 4.2. Delivery receipt of handed over of cookstove to the first user is submitted and verified by VVB to confirm the start date. The crediting period for VCS began on 04-October-2012 and will end on 03-October-2022. The project proponent will also not claim GHG emission reductions under two schemes for the same period. The GHG credits from 04-October-2012 and will end on 03-October-2017 (First and Last date included) will be claimed under VCS only. An undertaking from the project participant confirms that project will not claim any other scheme benefits for the concerned monitoring period.

The cook stove distributed under the project activity is a portable, single-pot stove without chimney, natural draft and metal made stove specifically suitable for combustion of solid biomass. The cook stove broadly comprises of a combustion chamber, top plate for holding the utensils, grate for holding fuel during combustion and bottom plate that facilitates ventilation of air. The combustion chamber is cylindrical shaped and made up of mild steel. One side of the chamber of improved cook stove is opened for feeding of fuel. The chamber top plate is die cast and made up of cast iron.

**Figure 1: Diagram of Improved Cook stove**

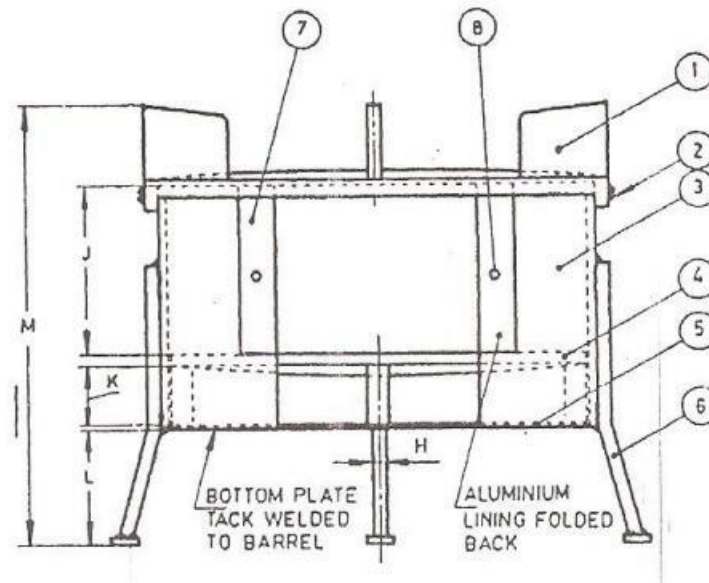

1. Top plate,

2. Screw,
3. Barrel,
4. Grate,
5. Bottom Plate,
6. Legs,
7. Aluminum Lining and
8. Rivet

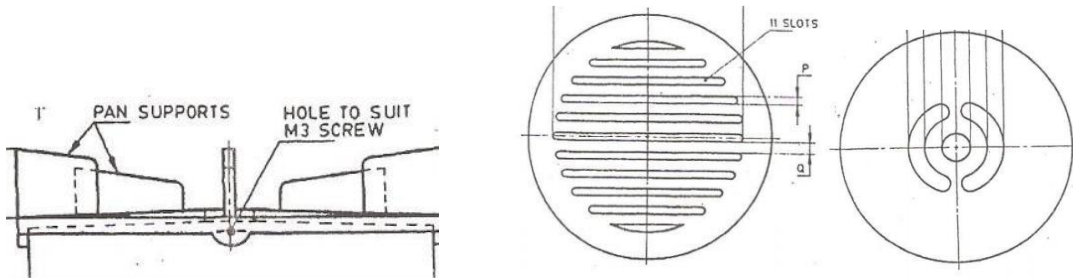

Figure 1.a. Top Plate Figure

1.b. Grate Figure 1.c. Bottom Plate

**Figure 2: Improved Cook stove**



Material used for manufacturing of each component of the cook stoves are:

<i>Component</i>	<i>Material</i>
<i>Top plate</i>	<i>Cast iron</i>
<i>Grate</i>	<i>Cast iron</i>
<i>Barrel</i>	<i>Mild steel</i>
<i>Bottom Plate</i>	<i>Mild steel</i>

Lining	Aluminium
Perforated Sleeve	Mild steel
Handle	Mild steel
Pan Support	Mild steel sheet-flat-rod
Legs	Mild steel sheet and rod

Above details has been verified by the VVB with the technical specification of Vikram cookstove and found correct.

The geographical boundary for projects located in India is delineated in the form of extreme geographic coordinates of India as follows:

The project is located in state Maharashtra, India.

The list of division is given below:

The list of division wise district is given below:

Division: Konkan

District: Raigad, Thane, Ratnagiri, Sindhudurg

Division: Nashik

District: Nashik, Dhule, Nandurbar, Jalgaon, Ahmednagar

Division: Pune

Districts: Pune, Sangli, Satara, Solapur and Kolhapur

Division	District	Latitude	Longitude
Konkan	Raigad	17.51 - 19.80 °N	72.51 - 73.40 °E
	Thane	18.70 - 20.33 °N	72.75 - 73.80 °E
	Ratnagiri	16.30 - 18.00 °N	73.00 - 74.00 °E
	Sindhudurg	15.37 - 16.40 °N	73.19 - 74.18 °E
Nashik	Nashik	18.33 - 20.53 °N	73.16 - 75.16 °E
	Dhule	20.63 - 22.01 °N	73.83 - 75.18 °E
	Nandurbar	21.00 - 22.03 °N	73.31 - 74.32 °E
	Jalgaon	20.00 - 21.00 °N	74.92 - 76.47 °E
	Ahmednagar	18.20 - 19.90 °N	73.90 - 75.50 °E
Pune	Pune	17.90 - 18.52 °N	73.32 - 75.17 °E
	Sangli	16.87 - 17.10 °N	73.43 - 75.00 °E
	Satara	17.50 - 18.11 °N	73.33 - 74.54 °E
	Solapur	17.10 - 18.32 °N	74.42 - 76.15 °E
	Kolhapur	15.00 - 17.00 °N	73.00 - 74.00 °E

During the Current Monitoring Period from 06-December-2012 and will end on 05-December-2017 (First and Last date included) the project activity is contributing to the GHG reductions of 62, 159 tCO<sub>2e</sub>.

## 2 VALIDATION AND VERIFICATION PROCESS

### 2.1 Method and Criteria

A competent assessment team is selected prior to the start of the validation and verification. The team is selected to cover the technical area(s), sectoral scope(s) and relevant host country experience for evaluating the VCS project activity. Additionally, a competent Technical Reviewer or Technical Reviewer Team is appointed to conduct checks on quality and completeness.

The validation and verification team performs first a desk review, followed by an on-site visit, which results in the formation of a draft report and a list of findings. The next step involves the evaluation of the findings through direct communication with the PPs and then finally the preparation of the gap validation and verification report. Joint validation and verification report and other supporting documents then undergo an internal quality control by the CB “Environment and energy” before submission to the VCS.

The validation, verification team and the technical reviewers consist of the following personnel:

Role/Qualification	Last Name	First Name	Country
Team Leader, Validator, Verifier & Technical Expert	Murty	Eswar	India
Technical Reviewer (TR)	Meesa	Srikanth	India

The validation and verification are not meant to provide any consulting towards the project participants. However, stated requests for clarifications and/or corrective actions may have provided input for improvement of the combined project description and the Monitoring report. The information provided by the project participants is assessed by applying the means of verification specified in the VCS v4.2, Toolkit and the VVS v3.

## 2.2 Document Review

Describe how the joint validation and verification was performed as an audit where the project description, monitoring report and any supporting documents were reviewed, cross-checked and compared with identified and stated requirements.

The Project Description was uploaded to VCS registry and made available for public comments. Thus, publication has been initiated before the validation activity started. Based on the published PD& MR the assessment team has performed a desk review to: verify the completeness of the Project and data and the information presented in the submitted VCS PD.

check the compliance of the submitted VCS PD with respect to the VCS 4.2 standard requirements such as applicability of the methodology, additionality, monitoring methodology and whether the project was implemented as per the PD. was carried out. Particular attention to the frequency, credibility and accuracy of the submitted data, and the quality assurance and quality control procedures followed,

evaluate the monitoring management and the quality of the submitted data and information with respect to the VCS principles in the context of their influence on the generation and reporting of emission reductions.

The following table lists the documentation that was reviewed during the validation process

S. No.	Document Reference
1	VCS Standard v4.2 and other VCS guidelines
2	Applied Methodologies: AMS-II.G ver. 03: Energy efficiency measures in thermal applications of non-renewable biomass
3	VCS project 2428 listing - Verra Search Page
4	VCS PD version 03 dated 16-August-2022
5	ER calculations and estimates version 03 dated 16-August-2022
6	Tripartee agreement
7	Ownership of the project

8	Evidence for start date of delivery receipt of cook stove
9	No double counting evidence
10	Technical specifications of cook stoves
11	Sample Stove installation cards in Nanded and Beed
12	BEE database for baseline
13	Monitoring database
14	Project boundary kml files
15	Thermal efficiency test result from manufacturer of ICS
16	TERI note-Rural energy data sources and estimations in India
17	India-State of Forest Report 2019
18	Declaration form distributor Dawda Traders for ICS distribution
19	Declaration/Undertaking from EKI Energy Services for the ownership , no double counting of ICS dated 27/10/2021
20	VCS MR (version 03)
21	Survey report

Above stated documents were referred and reviewed as part of the gap validation and verification assessment.

## 2.3 Interviews

The VVB has not conducted the on-site inspection for this current monitoring period due to obligations imposed by COVID 19. However, the VVB has ensured that reasonable level of assurance has been achieved as per Verra regulations on the relaxation of mandatory site visits by the VVB due to Covid-19. The VVB has conducted telephonic interviews and video calls to discuss with the client regarding the data and documents pertaining to the current validation and verification period. The interviews and discussions were conducted successfully.

No	Interviewee			Date	Subject	Team member
	Last name	First name	Affiliation			
1.	Kabra	Gopal	G K Energy Marketers Pvt. Ltd	18-November-2021	Implementation of the project, O&M activities, technical specifications, baseline, monitoring, applicability criteria and monitoring arrangements	Eswar Murty
2	Majumdar	Suvra	EKI Energy Services	18-November-2021	Project implementation and Monitoring	Eswar Murty
3	Dutta	Supratik	EKI Energy Services	18-November-2021	Project implementation and Monitoring	Eswar Murty
4	Chakraborty	Papia	CTran Consultant	18-November-2021	Third Party Survey	Eswar Murty

Telephonic interviews of household users by verification team:

S. no.	Agreement No.	Name	Address
1	GKEMPLPH-14-346	Kisan Ananda Khodke	Aurangabad
2	GKEMPLPH-14-1052	Umabai Gangaram Waghmode	Jalna
3	GKEMPLPH-23-13726	Prakash Uttam Aher	Kolhapur
4	GKEMPLPH-14-1711	Santosh Vitthal Mahale	Hingoli
5	GKEMPLPH-14-4037	Sambhaji Manik Bade	Buldhana
6	GKEMPLPH-14-13988	Rohidas Karbhari Tidke	Gondia

7	GKEMPLPH-14-3790	Radeshyam Madhukar Katyarmal	Latur
---	------------------	---------------------------------	-------

## 2.4 Site Inspections

As discussed in the above section 2.3, a remote site visit was undertaken by the verification team on 18/11/2021 to carry out the following;

- An assessment of the project design and technical specification, project location, project boundary, additionality, baseline scenario, baseline methodology, GHG emissions quantification and implementation status and operation of the project activity as per the PD.
- A review of information flows for generating, aggregating and reporting the monitoring parameters and monitoring methodology;
- Interviews with relevant personnel to determine whether the operational and data collection procedures are implemented in accordance with the monitoring plan in the PD;

The assessment team has verified sufficient appropriate audit evidences, to reduce audit risk to an acceptably low level as requisite to achieve reasonable level of assurance for the current validation.

## 2.5 Resolution of Findings

2 corrective action requests, 3 Clarification requests have been raised during the validation and verification process.

CL from joint validation and verification

<b>CL ID</b>	01	<b>Section no.</b>	1.1	<b>Date:</b> 18/11/2021
<b>Description of CL</b>				
The start date of the project activity as per the PD is 25 March 2010, where as it is 25 March 2011 as per the MR. PP to clarify the correct start date and also explain why the start date of crediting period is not the same as project start date as per VCS,				
<b>Project participant response</b>				<b>Date:</b> 20/05/2022

The start date of the project activity is 04-October-2012. The project activity relating to improved cook stove usage by the end user does not require any construction or significant pre-project implementation, nor financial commitment on the part of end user. The real action pertaining to the earliest date of handover of improved cook stoves to beneficiary (also considered as date of onset of GHG emission reductions) under the project activity is considered as the start date as per project start date definition under paragraph 3.7 of the VCS Standard. The distribution was initiated once all the Improved cookstoves (disseminated under the project activity) were supplied to the office of the concerned line department by the manufacturer and the project proponent has completed signing of tripartite agreement with selected beneficiaries.

The date of supply/ receipt of first lot of improved cookstoves from manufacturer to the regional office of the line department was considered as start date under the CDM registered PDD (evidenced through acknowledgement of the delivery receipt of the line department) as per CDM definition of Start Date. The start date referred to in the registered CDM-PDD was mirrored in the VCS PD. Since the date does not resembles to handover of the cookstoves to beneficiary and does not result in onset of actual emission reduction therefore the same cannot be considered as start date under VCS mechanism and therefore revised with date of distribution/ handover of improved cookstoves to beneficiary. Sample delivery receipt submitted as evidence.

**Documentation provided by project participant**

1. Monitoring Report (02)
2. tripartite agreement
3. Delivery Receipt
4. ER sheet (version 02)

**DOE assessment**

**Date:** 23/05/2022

The first date of actual handover of ICS to beneficiary was on 04 October 2012 as mentioned in the Emission Reduction (ER) sheet and same date has been considered as first cookstove operation date of the project as per project start date definition of section 3.7 of the VCS Standard V.4.2.

Delivery receipt of handed over of cookstove is submitted and verified by audit team to confirm the date. CL is closed.

<b>CL ID</b>	02	<b>Section no.</b>	1.1	<b>Date:</b> 18/11/2021
<b>Description of CL</b>				
<ol style="list-style-type: none"> <li>1. PP to provide the following documents Tripartite agreement</li> <li>2. Ownership of the project</li> <li>3. Project start date evidence</li> <li>4. No double counting evidence</li> <li>5. Technical specifications of cook stoves</li> <li>6. Sample Stove installation cards in Nanded and Beed</li> <li>7. Installation database with contact details</li> </ol>				
<b>Project participant response</b>				<b>Date:</b> 20/05/2022
Following documents submitted <ol style="list-style-type: none"> <li>1. Tripartite agreement</li> <li>2. Ownership of the project established through tripartite agreement</li> <li>3. Project start date established through delivery receipt</li> <li>4. Declaration by project participant claiming no double counting evidences</li> <li>5. Technical specifications of cook stoves</li> <li>6. Sample Stove installation cards established through delivery receipt</li> <li>7. Installation database</li> </ol>				
<b>Documentation provided by project participant</b>				
<ol style="list-style-type: none"> <li>1. Tripartite agreement</li> <li>2. Ownership of the project established through tripartite agreement</li> <li>3. Project start date established through delivery receipt</li> <li>4. Declaration by project participant claiming no double counting evidences</li> <li>5. Technical specifications of cook stoves</li> <li>6. Sample Stove installation cards established through delivery receipt</li> <li>7. Installation database</li> </ol>				
<b>DOE assessment</b>				<b>Date:</b> 23/05/2022
All documents are submitted by the project proponent in line with the requirement. CL is closed.				

<b>CL ID</b>	03	<b>Section no.</b>		<b>Date:</b> 18/11/2021
<b>Description of CAR</b>				

1. For the monitoring parameter- '**Number of days of functioning of traditional cook stoves**' it is mentioned as zero for the whole monitoring period. The monitoring database provided does not mention anything on the usage of old stoves or operational status of ICS.
2. For the monitoring parameter- '**No of cook stoves in use**'- the percentage of cook stoves operational in the monitored period are given as 90-95% for the period where as the Monitoring survey report mentions that all stoves are operational during the period and there is no non functional cook stove.

PP to clarify the above and provide us with the complete survey and monitoring database.

**Project participant response**

**Date:** 20/05/2022

1. The operational status of improved cook stoves is outlined in the monitoring database 1)
2. Based on the monitoring records and records of operation and maintenance the improved cook stoves were ascertained to be operational during the monitoring period.
  - 2) However during survey in case beneficiaries were evaluated/identified to be using improved cook stoves for a limited period along with usage of traditional cookstoves the beneficiaries are considered as partial users. Partial users are beneficiaries /household, those who have not discontinued using of ICS but have been using ICS for a limited period and also using traditional cookstoves for the purpose of cooking along with ICS. Since the number of days of operation of partial ICS usage during a particular crediting period is hard to ascertain (uncertainty of estimation), therefore as a conservative approach the beneficiaries /household using ICS partially are considered as discontinued users for the purpose of estimating emission reduction.

Period	No. of Dis-continued user	Date of Survey	Number of beneficiaries surveyed	% of partial users	% of users used ICS only
4 Oct 12 - 3 Oct 13	0	24-11-2013 26-11-2013 05-12-2013 01-12-2013 08-01-2014 10-01-2014 12-01-2014 12-01-2014 14-01-2014 14-01-2014 10-01-2014 08-01-2014 06-12-2013 04-12-2013 02-12-2013 30-11-2013 28-11-2013 26-11-2013 24-11-2013	160	3.13%	96.88%
4 Oct 13 - 3 Oct 14	0	08-01-2015 26-11-2014 05-12-2014 01-12-2014 24-11-2014 10-01-2015 12-01-2015	160	5%	95%

		12-01-2015 14-01-2015 14-01-2015 10-01-2015 08-01-2015 24-11-2014 26-11-2014 28-11-2014 30-11-2014 02-12-2014 04-12-2014 06-12-2014			
4 Oct 14 - 3 Oct 15	0	12-01-2016 01-12-2015 08-01-2016 12-01-2016 10-01-2016 05-12-2015 24-11-2015 26-11-2015 10-01-2016 14-01-2016 08-01-2016 14-01-2016 06-12-2015 02-12-2015 30-11-2015 04-12-2015 28-11-2015 26-11-2015 24-11-2015	160	6.88%	93.13%
4 Oct 15 - 3 Oct 16	0	05-12-2016 08-01-2017 24-11-2016 26-11-2016 01-12-2017 12-01-2017 10-01-2017 12-01-2017 06-12-2016 08-01-2017 04-12-2016 02-12-2016 14-01-2017 14-01-2017 10-01-2017 26-11-2016 24-11-2016 30-11-2016 28-11-2016	160	8.13%	91.88%

4 Oct 16 - 3 Oct 17	0	24-11-2017 10-01-2018 12-01-2018 02-12-2017 30-11-2017 28-11-2017 26-11-2017 24-11-2017 06-12-2017 04-12-2017 12-01-2018 26-11-2017 05-12-2017 01-12-2017 08-01-2018 14-01-2018 14-01-2018 10-01-2018 08-01-2018	160	9.38%	90.63%	
---------------------	---	--	-----	-------	--------	--

**Documentation provided by project participant**

1. Monitoring Report (version 02)
2. ER sheet (version 02)
3. Updated Monitoring Database

**DOE assessment**
**Date:** 23/05/2022

1. Operational status of improved cook stoves has outlined in the monitoring database
2. Beneficiaries /household using ICS partially are not counted now in the ER calculation and accordingly cookstove user nos. are adjusted for ER calculation. This is conservative approach so it can be accepted. CL is closed now

CAR from joint validation and verification

<b>CAR ID</b>	01	<b>Section no.</b>	1.12	<b>Date:</b>	18/11/2021
<b>Description of CAR</b>					
The PD does not provide the number and names of villages under which the stove distribution is done.					
<b>Project participant response</b>					<b>Date:</b> 20/05/2022
The List of villages are included in the monitoring database.					

<b>Documentation provided by project participant</b>	
1. Monitoring Report (version 02) 2. ER sheet (version 02) 3. Updated monitoring database	
<b>DOE assessment</b>	<b>Date: 23/05/2022</b>
As the list of villages are included now in the monitoring database, thus, CAR is closed.	

<b>CAR ID</b>	02	<b>Section no.</b>	3.4	<b>Date:</b>	18/11/2021
<b>Description of CAR</b>					
MR mentions that the monitoring period is from 15-December-2012 to 14-December-2017, however the monitoring parameter section and the monitoring database sheet mentions as 1 <sup>st</sup> to 5 <sup>th</sup> monitoring period. PP to clarify and make necessary revision.					
<b>Project participant response</b>					<b>Date: 20/05/2022</b>
The parameters is corrected in the revised MR and denoted as year 1 to year 5					
<b>Documentation provided by project participant</b>					
Monitoring Report (version 02)					
<b>DOE assessment</b>					<b>Date: 23/05/2022</b>
Monitoring period in monitoring parameter sections are corrected and consistent now throughout the MR (version 02). CAR is closed.					

### 2.5.1 Forward Action Requests

No FAR was raised during gap validation and verification process.

## 3 VALIDATION FINDINGS

### 3.1 Project Details

The project activity involves the distribution of improved cook stoves as per IS13152 (Part 1): 1991 (Solid Biomass –Chulha Part 1 (Metallic)) of CPRI Design, Type I design approved by Bureau of Indian Standard. The Ministry of New and renewable Energy has approved Vikram cook stoves and Fabricators for manufacturing of the cook stoves as per the above specifications and the same stoves are distributed in this project.

This project involves distribution of improved cook stoves in tribal households (Schedule Tribe) and families living below the poverty level (BPL) and Scheduled Tribes (ST) households in rural areas of Aurangabad, Jalna, Parbhani, Hingoli, Beed, Nanded, Osmanabad, Latur, Buldhana, Akola, Washim, Amravati, Yavatmal, Wardha, Nagpur, Bhandara, Chandrapur, Gadchiroli and Gondia districts which lies in Aurangabad, Amravati and Nagpur Divisions in Maharashtra. The improved cook stoves through replacement of inefficient traditional cook stove will contribute towards reduction of greenhouse gas emission resulting in the reduction of firewood consumption leading to climate change mitigation in a sustainable manner.

As confirmed through the remote inspection, the technology deployed under the project activity is single pot, portable, metallic, improved biomass cook stoves made of cast iron for combustion of solid biomass, which are manufactured in accordance to IS 13152, Part-1: 1991, CPRI Design Type I standard. The cook stove has been tested for thermal efficiency of 29.88% as per water boiling test protocol specified in IS 13152, Part 1: 1991. The efficiency test report provided to assessment team was reviewed and it was concluded that the efficiency test was conducted in accordance with the procedure stipulated in the applied methodology AMS II-G., Energy efficiency measures in thermal applications of non-renewable biomass, Version 03.0.

The individual households using ICS has signed an agreement with the PP along with Vikram Stoves (Manufacturer) & entered into contractual agreement with the beneficiaries by virtue of which, the end user will confirm use of cook stove as well as transfer the CER right to the Project Participant. The sample agreement was validated by the assessment team for the cook stoves and found in line with the VCS-PD. The estimated total amount of emission reductions over the chosen 10-year “fixed crediting period” is less than 300,000 tCO<sub>2</sub>e. The estimated amount of emission reductions per annum are 13,050 tCO<sub>2</sub>e.

Validation team has checked the summary description of the project defined in the VCS PD and found consistent with the registered CDM PDD.

During the Current Monitoring Period from 04-October-2012 to 03-October-2017 (First and Last date included) the project activity is contributing to the GHG reductions of 61,559 tCO<sub>2</sub>e.

### **Project Proponent**

As per CDM registered PDD “M/s G K Energy Marketers Pvt. Ltd.” is the project proponent. In VCS PD also the PP name is correctly mentioned as “M/s G K Energy Marketers Pvt. Ltd.”. The name of the person, address and phone number is assessed correct for VCS (gap validation and verification) purpose. Hence, Clause 1.5 as depicted in the VCS PD for gap validation is acceptable to the assessment team.

The other entities involved in this project activity is “EKI Energy Services Limited” as project consultant.

### **Project Start Date**

The start date of the project is considered as the date when the cook stove is distributed to the end users selected by the concerned line department of Rural Development Department. i.e. 04-October-2012 and the same is correct as per the definition of start date of VCS standard version 4.2. The validation team has verified the receipt of the first cook stove. Thus, start date of the project activity is correct as per the requirement of Para 3.7 of VCS standard version 4.2. Hence, Clause 1.5 as depicted in the VCS PD for gap validation is acceptable to the assessment team.

### **Project Crediting Period**

The Crediting period of the project under CDM started on 30-December-2013 and will end on 29-December-2022. The date of supply/ receipt of first lot of improved cookstoves from manufacturer to the regional office of the line department was considered as start date under the CDM registered PDD (evidenced through acknowledgement of the delivery receipt of the line department) as per CDM definition of Start Date. The start date referred to in the registered CDM-PDD was mirrored in the VCS PD. Since the date does not resembles to handover of the cookstoves to beneficiary and does not result in onset of actual emission reduction therefore the same cannot be considered as start date under VCS mechanism and therefore the date of distribution/ handover of improved cookstoves to first beneficiary i.e. 04-October-2012 is taken as start date of VCS in line with VCS standard, version 4.2. Delivery receipt of handed over of cookstove to the first user is submitted and verified by VVB to confirm the start date. The cookstoves under the project activity is distributed between 04-October-2012 to 16-December-2012, it is therefore the start date of

crediting period is considered from 04-October- 2012. The crediting period for VCS began on 04-October-2012 and will end on 03-October-2022 (First and Last date included) i.e. ten years (fixed).

#### Project Scale and Estimated GHG Emission Reductions or Removals

The proposed project activity was categorized as "Project", since the estimated average annual GHG emission reductions is 13,050 tCO<sub>2e</sub>, which is lower than 300,000 tCO<sub>2e</sub> per year as per the registered CDM PDD.

#### Project Location

The project location of the project activity is checked by the assessment via Google earth software and found correct in line with the CDM PDD.

#### Conditions Prior to Project Initiation

Through reviewing the registered CDM PDD and validation report at UNFCCC website <https://cdm.unfccc.int/Projects/DB/RWTUV1355663171.86/view> , it is confirmed that the project is a Greenfield project. The improved cook stoves through replacement of inefficient traditional cook stove contributes towards reduction of greenhouse gas emission. Assessment team checked the same with PP during the remote audit and also cross checked with CDM PDD and validation report. Thus clause 1.13 as depicted in the VCS PD for gap validation is acceptable to the assessment team.

#### Compliance with Laws, Statutes and Other Regulatory Frameworks

The project is registered under CDM and UNFCCC (Registration ID -8809). The project is also approved by the DNA and a copy of the approval is available on the UNFCCC page. The project activity is not mandatory by any local or national laws. Same is confirmed from section B.3 of the registered CDM PDD. Thus clause 1.14 as depicted in the VCS PD for gap validation is acceptable to the assessment team

#### Ownership and other programs-

##### Right of use

The project activity is owned by "M/s G K Energy Marketers Pvt. Ltd.". The ownership of the project activity is verified through the following documents:

Beneficiary agreements: Tripartite agreement between PP (M/s G K Energy Marketers Pvt. Ltd), Supplier (Vikram Stoves & Fabricators) and end users CDM PDD

Project has been registered with UNFCCC under Clean Development Mechanism program. Registration reference number is 8809. Project Proponent has submitted undertaking for not availing other forms of environmental credit for the same crediting period under consideration. PP is registering in the VCS program with the crediting period effective from 04-October-2012. And PP also confirmed that the project will not claim CERs for the period when the VCU are claimed under VCS.

Other forms of environmental credit sought or received and eligible to be sought or received:

Project has been registered with UNFCCC under Clean Development Mechanism program. Registration reference number is 8809. Project Proponent has submitted undertaking for not availing other forms of environmental credit for the same crediting period under consideration. PP is registering in the VCS program with the crediting period effective from 04-October-2012. And PP also confirmed that the project will not claim CERs for the period when the VCU are claimed under VCS.

PP also submitted undertaking for Project neither has any intends to generate any form of GHG related environmental credit for neither GHG emission reductions nor removals claimed under the VCS program. Thus clause 1.16 as depicted in the VCS PD for gap validation is acceptable to the assessment team.

Rejection by other GHG programs:

The project has not been rejected by other GHG programs.

**Additional information relevant to the project, including:**

**- Eligibility criteria for grouped projects**

Not applicable to the project activity.

Leakage management for AFOLU projects

Not applicable to the project activity.

Commercially sensitive information

No commercially sensitive information has been excluded from the public version of the project description.

The improved cook stoves through replacement of inefficient traditional cook stove will contribute towards reduction of greenhouse gas emission resulting in the reduction of firewood consumption leading to climate change mitigation in a sustainable manner.

Further the GHG emission reductions generated by the project activity has not been included by any other an emissions trading program or any other mechanism that includes

GHG allowance trading. Also, the project has not received any other form of environmental credit and has not been participated/rejected under any other GHG programs.

**Sustainable Development**-The project activity contributes to the sustainable development by MoEFCC and has the benefits such as reduction in indoor air pollution, reduction in time spent and distance travelled for fuel wood collection, conservation of forest by reducing rate of forest degradation /deforestation and thereby reducing GHG emissions from the environment. There are other economic benefits such as opportunities for local communities involved in monitoring, training of users, undertaking periodic maintenance and post life time replacement.

## Conclusion

In view of the assessment of VCS PD and supporting documents as listed in section 2.2. of this report, the validation team is able to confirm that the description contained in the VCS PD of the project activity provides the reader with a clear understanding of the precise nature of the project activity and the technical aspects of its implementation. Consequently, TUV SUD confirms that the project description of the project contained in the VCS PD to be complete and accurate. The VCS PD complies with the relevant forms and guidance for completing the VCS PD.

## 3.2 Participation under Other GHG Programs

The present project activity is registered under CDM mechanism (UN reference number: 9503). The project can be traced via link:

<https://cdm.unfccc.int/Projects/DB/RWTUV1355663171.86/view>

The gap validation is performed for the project activity as per Para 3.20 of VCS standard version 4.2. As per the requirement of this template following are the observation of the assessment team:

1. The project is registered under CDM mechanism and UN reference number of the project is 9503. The project title is "Distribution of Improved cook stove - Phase 14".
2. The present validation (gap validation) is under VCS mechanism and assessment of clause (1.1, 1.2, 1.3, 1.5, 1.6, 1.7, 1.9, 1.10, 1.12, 1.13, 1.14, 1.15.1, 1.16, 1.17 and 3.6) of the VCS Project Description Template.
3. The project is eligible under Para 3.20 of VCS standard version 4.2.

### 3.3 Safeguards

#### 3.3.1 No Net Harm

The project activity is utilization of Improved Cook stove for cooking in rural households and does not involve any negative impact. As no potential negative environmental and socio-economic impacts identified, hence this section is not required.

#### 3.3.2 Local Stakeholder Consultation

Local stakeholder consultation has been conducted at the time of project registration. For on-going stakeholder's communication, PP have made the provision of the grievance register. Assessment team checked the grievance registers provided by PP and found that local stakeholders/beneficiaries can anytime lodge their grievances if any in the register over the operational life time of the project. During the remote audit, it was confirmed that PP is responsible to address any grievances received. No grievance received during the current monitoring period.

#### 3.3.3 Environmental Impact

No potential negative environmental or socio-economic impacts have been identified for the project.

#### 3.3.4 Public Comments

No comments have been received

#### 3.3.5 AFOLU-Specific Safeguards

Not applicable since this is a non-AFOLU project.

### 3.4 Application of Methodology

#### 3.4.1 Title and Reference

Category: AMS II-G., Energy efficiency measures in thermal applications of non-renewable biomass, Version 03.0. Assessment team checked the type and category of the project activity and found that the project is eligible under Type I and renewable category of project.

#### 3.4.2 Applicability

Not applicable being GAP Validation & Verification project.

### 3.4.3 Project Boundary

Not applicable being GAP Validation & Verification project.

### 3.4.4 Baseline Scenario

Not applicable being GAP Validation & Verification project.

### 3.4.5 Additionality

Not applicable being GAP Validation & Verification project.

### 3.4.6 Quantification of GHG Emission Reductions and Removals

Not applicable being GAP Validation & Verification project.

### 3.4.7 Methodology Deviations

The project activity used AMS II-G., Energy efficiency measures in thermal applications of non-renewable biomass, Version 03.0, which is as per the registered CDM PDD and thus no deviation is sought regarding the methodology. The project complies with all the requirements of the methodology and thus deviation to the methodology is not a requirement for the present monitoring period.

### 3.4.8 Monitoring Plan

Not applicable being GAP Validation & Verification project.

## 3.5 Non-Permanence Risk Analysis

Not applicable.

# 4 VERIFICATION FINDINGS

## 4.1 Accuracy of GHG Emission Reduction and Removal Calculations

The VVB had telephonic/Teams interviews with concerned onsite persons, households and has reviewed documents & photographs submitted by PP; assessment team concluded that the project activity is implemented and operated in-line with the registered VCS PD & MR. 14,517 nos. of ICS have been installed in the project activity.

There is no change in the project design or operation and monitoring practices at site which can alter the applicability or additionality of the project activity. In addition to the interviews with PP, assessment team have checked the all the documentation and found that the project activity is implemented as per the VCS PD and Monitoring report submitted by the PP for current monitoring period.

Parameters fixed in ex-ante

Means of verification	The verification team assessed whether the data and calculations of GHG emission reductions achieved resulting from the MR. The verification team has checked whether calculations of baseline GHG emissions, project GHG emissions and leakage GHG emissions have been carried out in accordance with the formulae and methods described in the monitoring plan of the MR.
Findings	CAR 2 and CL 3 was raised during the verification process and closed successfully. Please refer section 2.5 of this report for the detail closure of the CAR and CL.
Conclusion	<p>All the ex-ante &amp; monitored parameters are described section 4.1 &amp; 4.2 of the MR transparently. It is confirmed that all the ex-ante parameters have been correctly used in the emission reduction calculation.</p> <p><b>Ex-ante Parameter:</b></p> <p><b>B<sub>old</sub></b> = Quantity of woody biomass used in absence of the project activity (tonnes/ household/year)</p> <p>The value 1.469 is based on historical database sourced from Teri Energy Data Directory Yearbook for 2010 and it is used for calculation of baseline Emission and is found to be consistent with the registered CDM-PDD</p> <p><b>η<sub>new</sub></b> = Efficiency of the cook stove being deployed as a part of the project activity (%)</p> <p>The value 29.88% is obtained from Test report issued by Biomass Cook stove Testing Centre, Dept. of Renewable Energy Sources, Udaipur, and it is used for calculation of baseline Emission and is found to be consistent with the registered CDM-PDD.</p> <p><b>B<sub>y,savings</sub></b> = Quantity of woody biomass saved due to implementation of the project activity 9 tonne/household/year)</p> <p>By, savings is calculated using equation  <math display="block">By, savings = B_{old} * (1 - \eta_{old} / \eta_{new})</math></p>

	<p>The value 0.9774 is used for calculation of baseline Emission and is found to be consistent with the registered CDM-PDD.</p> <p>Energy Saving per cook stove or household = Energy saving per cook stove due to improved efficiency of the distributed cook stove (GWhth/household/year)</p> <p>Energy Saving is calculated using equation</p> $\text{Energy Saving} = B_{y, \text{ saving}} * \text{NCV}_{\text{biomass}}$ $= B_{\text{old}} * (1 - \eta_{\text{old}}/\eta_{\text{new}}) * \text{NCV}_{\text{biomass}}$ <p>The value 0.00407 is used for calculation of baseline Emission and is found to be consistent with the registered CDM-PDD.</p> <p><math>F_{\text{NRB},y}</math> = The factors relates to the fraction of non-renewable biomass</p> <p>The value 87.9% is calculated using fuel wood demand and supply of biomass. Below Poverty Line (BPL) and Scheduled Tribes (ST) households in rural areas of Aurangabad, Jalna, Parbhani, Hingoli, Beed, Nanded, Osmanabad, Latur, Buldhana, Akola, Washim, Amravati, Yavatmal, Wardha, Nagpur, Bhandara, Chandrapur, Gadchiroli and Gondia districts which lies in Aurangabad, Amravati and Nagpur Divisions in Maharashtra and it is used for calculation of baseline Emission and is found to be consistent with the registered CDM-PDD.</p> <p>During the verification, all relevant monitoring parameters of the registered monitoring plan have been verified with regard to the appropriateness of the verification method; the correctness of the values applied for ER calculation, the accuracy and applied QA/QC measures. All monitoring parameters have been measured / determined without material misstatements and are in line with all applicable standards and relevant requirements. It is confirmed that the monitoring mechanism is effective and reliable.</p> <p>Therefore, from the document review and remote inspection, it is confirmed that all the parameters were monitored in accordance with the registered monitoring plan during the monitoring period. Following are the details of monitoring in accordance with the monitoring plan of the registered CDM PDD &amp; VCS PD:</p> <p><math>\eta_{\text{new}}</math> = Efficiency of the system being deployed in project activity (%)</p> <p>During the remote inspection and through the review of efficiency test reports, it has been confirmed that the value is calculated on annual basis through representative sampling as per Water Boiling Test Protocol indicated in IS 13152 (Part 1): 1991 for solid biomass cook stove. The minimum value of tested efficiency or 29.88% which so ever is lower is used to calculate emission reduction of the systems for</p>
--	--

	<p>particular year of operation, which was found to be acceptable and consistent with the registered CDM PDD and gap validation PD as verified by the verification team.</p> <p>Verification team reviewed the Third-party efficiency test reports by Regional Test Centre, School of Energy Studies (which is an accredited test center) and found the source of the data be consistent. Monitored values are as below:</p>			
	Period	Date of Monitoring	Number of Improved cookstoves assessed	Minimum efficiency of the lot
	4 Oct 12 - 3 Oct 13	24-11-2013 26-11-2013 05-12-2013 01-12-2013 08-01-2014 10-01-2014 12-01-2014 12-01-2014 14-01-2014 14-01-2014 10-01-2014 08-01-2014 06-12-2013 04-12-2013 02-12-2013 30-11-2013 28-11-2013 26-11-2013 24-11-2013	40	28.56%
4 Oct 13 - 3 Oct 14	08-01-2015 26-11-2014 05-12-2014 01-12-2014 24-11-2014 10-01-2015 12-01-2015 12-01-2015 14-01-2015 14-01-2015 10-01-2015 08-01-2015 24-11-2014 26-11-2014 28-11-2014 30-11-2014 02-12-2014 04-12-2014	40	27.81%	

		06-12-2014		
	4 Oct 14 - 3 Oct 15	12-01-2016 01-12-2015 08-01-2016 12-01-2016 10-01-2016 05-12-2015 24-11-2015 26-11-2015 10-01-2016 14-01-2016 08-01-2016 14-01-2016 06-12-2015 02-12-2015 30-11-2015 04-12-2015 28-11-2015 26-11-2015 24-11-2015	40	27.11%
	4 Oct 15 - 3 Oct 16	05-12-2016 08-01-2017 24-11-2016 26-11-2016 01-12-2017 12-01-2017 10-01-2017 12-01-2017 06-12-2016 08-01-2017 04-12-2016 02-12-2016 14-01-2017 14-01-2017 10-01-2017 26-11-2016 24-11-2016 30-11-2016 28-11-2016	40	26.20%
4 Oct 16 - 3 Oct 17	24-11-2017 10-01-2018 12-01-2018 02-12-2017 30-11-2017 28-11-2017 26-11-2017 24-11-2017 06-12-2017 04-12-2017 12-01-2018	40	26.07%	

		26-11-2017 05-12-2017 01-12-2017 08-01-2018 14-01-2018 14-01-2018 10-01-2018 08-01-2018														
	<p>No. cook stoves in use = The number of improved cook stoves distributed to households under the project activity (Numbers)</p> <p>During the remote inspection and through document review, it has been confirmed that the value is based on annual survey by third-party to evaluate the number of systems in operation.</p> <p>The percentage of cook stove in usage as estimated from the survey result, which is multiplied with the total number of cook stove to determine number of cook stove in operation and to be considered for the purpose of emission reduction calculation which was found to be acceptable and consistent with the VCS PD and the registered CDM PDD. However, in case beneficiaries were evaluated to be using improved cook stoves for a limited period along with usage of traditional cookstoves the beneficiaries are considered as partial users. Partial users are beneficiaries /household, those who have not discontinued using of ICS but have been using ICS for a limited period and also using traditional cookstoves for the purpose of cooking along with ICS. Since the number of days of operation of partial ICS usage during a particular crediting period is hard to ascertain (uncertainty of estimation), therefore as a conservative approach the beneficiaries /household using ICS partially are considered as discontinued users for the purpose of estimating emission reduction.</p> <p>Verification team reviewed the Third-party agency survey reports and database managed by the Project Participant and was found to be consistent. The verification team crosschecked the stove distribution database and the end user agreements and found it to be consistent.</p> <p>Number of improved cookstoves under operation:</p> <table border="1"> <thead> <tr> <th>Period</th> <th>No. of Dis-continued user</th> <th>Date of Survey</th> <th>Number of beneficiaries surveyed</th> <th>% of partial users</th> <th>% of users used ICS only</th> </tr> </thead> <tbody> <tr> <td>4 Oct 12 - 3 Oct 13</td> <td>0</td> <td>24-11-2013 26-11-2013 05-12-2013 01-12-2013</td> <td>160</td> <td>3.13%</td> <td>96.88%</td> </tr> </tbody> </table>					Period	No. of Dis-continued user	Date of Survey	Number of beneficiaries surveyed	% of partial users	% of users used ICS only	4 Oct 12 - 3 Oct 13	0	24-11-2013 26-11-2013 05-12-2013 01-12-2013	160	3.13%
Period	No. of Dis-continued user	Date of Survey	Number of beneficiaries surveyed	% of partial users	% of users used ICS only											
4 Oct 12 - 3 Oct 13	0	24-11-2013 26-11-2013 05-12-2013 01-12-2013	160	3.13%	96.88%											

			08-01-2014 10-01-2014 12-01-2014 12-01-2014 14-01-2014 14-01-2014 10-01-2014 08-01-2014 06-12-2013 04-12-2013 02-12-2013 30-11-2013 28-11-2013 26-11-2013 24-11-2013			
	4 Oct 13 - 3 Oct 14	0	08-01-2015 26-11-2014 05-12-2014 01-12-2014 24-11-2014 10-01-2015 12-01-2015 12-01-2015 14-01-2015 14-01-2015 10-01-2015 08-01-2015 24-11-2014 26-11-2014 28-11-2014 30-11-2014 02-12-2014 04-12-2014 06-12-2014	160	5%	95%
	4 Oct 14 - 3 Oct 15	0	12-01-2016 01-12-2015 08-01-2016 12-01-2016 10-01-2016 05-12-2015 24-11-2015 26-11-2015 10-01-2016 14-01-2016 08-01-2016 14-01-2016 06-12-2015 02-12-2015 30-11-2015 04-12-2015	160	6.88%	93.13%

			28-11-2015 26-11-2015 24-11-2015			
	4 Oct 15 - 3 Oct 16	0	05-12-2016 08-01-2017 24-11-2016 26-11-2016 01-12-2017 12-01-2017 10-01-2017 12-01-2017 06-12-2016 08-01-2017 04-12-2016 02-12-2016 14-01-2017 14-01-2017 10-01-2017 26-11-2016 24-11-2016 30-11-2016 28-11-2016	160	8.13%	91.88%
	4 Oct 16 - 3 Oct 17	0	24-11-2017 10-01-2018 12-01-2018 02-12-2017 30-11-2017 28-11-2017 26-11-2017 24-11-2017 06-12-2017 04-12-2017 12-01-2018 26-11-2017 05-12-2017 01-12-2017 08-01-2018 14-01-2018 14-01-2018 10-01-2018 08-01-2018	160	9.38%	90.63%
<p><b>Days of Operation=</b> The parameter relates to the number of days for which the cook stove in operation during the particular year (Number) During the remote inspection and through document review, it was confirmed that the data is calculated using the below equation:  Number of days of operation = 365–Average number of days the cook stove was non-functional</p>						

	<p>The number of non-functional days is based on the number of days the cook stoves were under repair/replacement as confirmed during the remote audit. Same is verified by the verification team through the review of the Third-party survey results carried out throughout the monitoring period. Value is taken as 365 days as per the third-party survey.</p> <p>Number of days of functioning of traditional cook stoves = The parameters refer to the number of days for which the traditional cook stove is being used by the household (Numbers)</p> <p>Verification team reviewed the annual third-party survey reports/15/ and found the source to be consistent.</p> <p>During the remote inspection and review of annual third-party survey reports, it was confirmed that the Number of days of operation of the traditional cook stove is obtained from the result of sample survey. The number of days of traditional cook stove as per the survey is used to obtain the average days of usage of the traditional cook stoves for all the households who still use the improved cook stoves of this project activity. This average day is used to arrive at a factor : = (365- Average number of days of traditional cook stove usage in all households /365)</p> <p>This factor is considered as leakage and is multiplied with baseline emission to obtain the leakage emission for the usage of traditional cook stoves as per Paragraph 20 (b) of the methodology. Value is taken as 0 as per the third-party survey.</p> <p>Number of Cook stove replaced= The parameters refer to the number of cook stove that are replaced (due to end of life time or damage) by the new cook stove with efficiency greater than or equal to 29.88%. (Number)</p> <p>Monitoring database has been checked to confirm that there has been no replacement. Hence, no new end user agreement and test certificate of the new system supplied are available.</p> <p><math>B_{y, savings}</math> = Quantity of woody biomass that is saved through the project activity (Tonnes/year/household)</p> <p>During the remote inspection and through the review of calculations in ER sheet, it has been confirmed that the value is calculated using the following equation: <math>B_{y, saving} = B_{old} * (1 - \eta_{old}/\eta_{new})</math>.</p> <p>Where, <math>B_{old}</math> is calculated based on number of days cook stove is operational as calculated above and per capita biomass consumption of 25.51 kg/person/month multiplied by 4.8 members per</p>
--	---

	rural household also factoring into the number of days for which the traditional cook stoves were in operation and the number of days of non-functioning of the improved cook stoves			
	The efficiency of the project system is tested on a representative sample, on annual basis as confirmed through the efficiency test reports			
	Period	Date of Monitoring	Number of Improved cookstoves assessed	Minimum efficiency of the lot
4 Oct 12 - 3 Oct 13	24-11-2013 26-11-2013 05-12-2013 01-12-2013 08-01-2014 10-01-2014 12-01-2014 12-01-2014 14-01-2014 14-01-2014 10-01-2014 08-01-2014 06-12-2013 04-12-2013 02-12-2013 30-11-2013 28-11-2013 26-11-2013 24-11-2013	40	28.56%	
4 Oct 13 - 3 Oct 14	08-01-2015 26-11-2014 05-12-2014 01-12-2014 24-11-2014 10-01-2015 12-01-2015 12-01-2015 14-01-2015 14-01-2015 10-01-2015 08-01-2015 24-11-2014 26-11-2014 28-11-2014 30-11-2014 02-12-2014 04-12-2014	40	27.81%	

		06-12-2014		
	4 Oct 14 - 3 Oct 15	12-01-2016 01-12-2015 08-01-2016 12-01-2016 10-01-2016 05-12-2015 24-11-2015 26-11-2015 10-01-2016 14-01-2016 08-01-2016 14-01-2016 06-12-2015 02-12-2015 30-11-2015 04-12-2015 28-11-2015 26-11-2015 24-11-2015	40	27.11%
	4 Oct 15 - 3 Oct 16	05-12-2016 08-01-2017 24-11-2016 26-11-2016 01-12-2017 12-01-2017 10-01-2017 12-01-2017 06-12-2016 08-01-2017 04-12-2016 02-12-2016 14-01-2017 14-01-2017 10-01-2017 26-11-2016 24-11-2016 30-11-2016 28-11-2016	40	26.20%
4 Oct 16 - 3 Oct 17	24-11-2017 10-01-2018 12-01-2018 02-12-2017 30-11-2017 28-11-2017 26-11-2017 24-11-2017 06-12-2017 04-12-2017 12-01-2018	40	26.07%	

	26-11-2017 05-12-2017 01-12-2017 08-01-2018 14-01-2018 14-01-2018 10-01-2018 08-01-2018			
	<p><b>Baseline Emissions:</b>                  The baseline emissions (<math>BE_y</math>) are calculated based on the following formula:  <math>BE_y = B_{y, savings} \times f_{NRB,y} \times NCV_{biomass} \times EF_{projected\ fossil\ fuel}</math></p> <p>It is noted that the formula and calculation used for baseline emission calculation in the monitoring report and ER sheet is in compliance with the registered CDM PDD. The default values and data used in the monitoring report is in-line with the registered PDD. Hence, acceptable to the verification team.</p> <p><b>Project Emissions:</b>                  As per the methodology, the <math>PE_y</math> is considered zero.                  Hence, <math>PE_y = 0</math> is acceptable to the verification team.</p> <p><b>Leakage:</b>                  As per the methodology and as defined in the registered CDM PDD, leakage emission per cook stove is estimated as difference between the emission reduction estimated considering the actual value of <math>B_{old}</math> and emission reduction estimated considering the value of <math>B_{old}</math> obtained by multiplying <math>B_{old}</math> with a net to gross adjustment factor of 0.95.</p>			

## 4.2 Quality of Evidence to Determine GHG Emission Reductions and Removals

Means of verification	All relevant documents were checked to assess the correctness and quality of data submitted by the project participants, which are used to determine emission reductions.
-----------------------	---

<p>Findings</p>	<p>CL 1, CL 2 and CAR 1 was raised during the verification process and closed successfully. Please refer section 2.5 of this report for the detail closure of the CAR and CL.</p>
<p>Conclusion</p>	<p>All records needed for monitoring are archived in line with the requirements of the registered monitoring plan. No significant lack of evidence and missing data were detected during remote audit discussion and inspection. Hence, the verification team confirms that the monitoring system ensures required quality of the monitoring system to ensure the quality of the monitored data. All internal data are subjected to QA/QC measures. The monitoring parameters have been measured / determined without material misstatements and is in line with all applicable standards and relevant requirements. The information inflow (from data generation, aggregation, to recording, calculation and reporting) is included in section 4.1 under each parameter and confirms to the requirement of the PDD.</p> <p>It was also verified through remote audit inspection that the team involved in the monitoring of project activity is well experienced. Hence, the verification team concludes that competent staff is employed by the project proponent to carry out the relevant tasks with sufficient accuracy. Furthermore, it was confirmed during remote audit discussion that internal training program for the monitoring staff is conducted on regular basis.</p> <p>The assessment team confirms that there have been no manual transposition errors between data sets during the current verification period.</p> <p><b>Comparison of Estimated Vs actual ERs:</b>  On comparison of achieved emission reductions (61,559 tCO<sub>2</sub>e) with the estimated emission reductions (65,250 tCO<sub>2</sub>e) for the monitoring period, a 4.13% decrease was observed. According to the applied methodology, the conservativeness of the achieved emission reduction was checked and the detailed emission reduction calculation has been transparently provided in the ER sheet. All the formulae and the calculation procedure were checked by the verification team. In the opinion of verification team, the assumptions, emission factors and default values that were applied in the calculations have been justified.</p>

# 5 VALIDATION AND VERIFICATION CONCLUSION

The assessment team opines that, with no qualifications or limitations that the project complies with the validation and verification criteria for projects and their GHG emission reductions or removals set out in VCS Version 4.

The VVB confirms that

- the methodology was appropriately applied and documented.
- the group project's eligibility criteria, project boundary, additionality, determination of emission reductions and monitoring management system have been assessed and found comply with the VCS requirements.
- the development and maintenance of records and reporting procedures are in accordance with the registered monitoring plan;
- the project is operated as planned and described in the project design document approved by the VCS;
- the installed equipment being essential for generating emission reduction runs reliably and is calibrated appropriately;
- the monitoring system is in place and generates GHG emission reductions data;
- the monitoring plan in Monitoring Report is as per the VCS PD and monitoring plan approved by the VCS;
- the approved monitoring plan in the approved VCS DD is as per the applied methodology;
- There is an audit trail that contains the evidence and records that validate the stated figures.

Based on the information we have seen and evaluated, we confirm that the project activity achieved the verified amount of reductions in anthropogenic emissions by sources of greenhouse gases that would not have occurred in the absence of the project activity. The verification period for the project activity is from 04-October-2012 to 03-October-2017.

Verified GHG emission reductions and removals in the above verification period:

Year	Baseline emissions or removals (tCO <sub>2</sub> e)	Project emissions or removals (tCO <sub>2</sub> e)	Leakage emissions (tCO <sub>2</sub> e)	Net GHG emission reductions or removals (tCO <sub>2</sub> e)
04-Oct-2012 -03-Oct-2013	11,515	0	576	10,939

04-Oct-2013 -03-Oct-2014	13,957	0	698	13,259
04-Oct-2014 -03-Oct-2015	13,482	0	675	12,807
04-Oct-2015 -03-Oct-2016	13,031	0	652	12,379
04-Oct-2016 -03-Oct-2017	12,816	0	641	12,175
	64,801	0	3,242	61,559