



**Verified Carbon
Standard**

DISTRIBUTION OF IMPROVED COOK STOVE - PHASE I



India's Largest Carbon Credit Developer & Supplier

Document Prepared By EKI Energy Services Limited

Contact Information: Office No. 201, EnKing Embassy Plot No. 48, Scheme No. 78
Part II, Vijay Nagar Indore – 452001

Project Title	Distribution of Improved cook stove - Phase I
Version	01
Date of Issue	16-January-2021
Prepared By	Mr. Pankaj Rajpoot
Contact	Assistant Manager Operations – GHG Services EKI Energy Services Limited Email ID : pankaj@enkingint.org T +91 731 42 89 086, M +91 7828347589 Address: Office no. 201, Plot 48, Scheme 78 part 2, Vijay Nagar Indore - 452010 (M.P, India) Website www.enkingint.org

CONTENTS

1	PROJECT DETAILS	3
1.1	Summary Description of the Project	3
1.2	Sectoral Scope and Project Type	6
1.3	Project Eligibility	6
1.4	Project Design	6
1.5	Project Proponent	7
1.6	Other Entities Involved in the Project	7
1.7	Ownership	7
1.8	Project Start Date	8
1.9	Project Crediting Period	8
1.10	Project Scale and Estimated GHG Emission Reductions or Removals	8
1.11	Description of the Project Activity	9
1.12	Project Location	11
1.13	Conditions Prior to Project Initiation	13
1.14	Compliance with Laws, Statutes and Other Regulatory Frameworks	13
1.15	Participation under Other GHG Programs	13
1.16	Other Forms of Credit	13
1.17	Additional Information Relevant to the Project	14
2	SAFEGUARDS	16
2.1	No Net Harm	16
2.2	Local Stakeholder Consultation	16
2.3	Environmental Impact	16
2.4	Public Comments	16
2.5	AFOLU-Specific Safeguards	16
3	APPLICATION OF METHODOLOGY	17
3.1	Title and Reference of Methodology	17
3.2	Applicability of Methodology	17
3.3	Project Boundary	20
3.4	Baseline Scenario	21
3.5	Additionality	21
3.6	Methodology Deviations	21
4	QUANTIFICATION OF GHG EMISSION REDUCTIONS AND REMOVALS	22
4.1	Baseline Emissions	22
4.2	Project Emissions	22
4.3	Leakage	22
4.4	Net GHG Emission Reductions and Removals	22
5	MONITORING	23
5.1	Data and Parameters Available at Validation	23
5.2	Data and Parameters Monitored	23
5.3	Monitoring Plan	24
	APPENDIX	25

1 PROJECT DETAILS

1.1 Summary Description of the Project

Purpose of the Project Activity

Purpose of the project activity is to facilitate clean cooking practices and reduce health risk due to indoor air pollution along with household drudgery amongst the tribal households (Schedule Tribe) and families living below the poverty level (BPL category) in villages of Maharashtra through dissemination of improved cook stoves. The improved cook stoves through replacement of inefficient traditional cook stove will contribute towards reduction of emission of greenhouse gas and by-products of incomplete combustion like black carbon, conservation of fuel wood and thereby preventing forest degradation. Successful operation of the project activity will encourage rural residents to shift from traditional cook stoves usage to the project improved and modern cook stove.

The higher efficiency portable, single pot cook stoves distributed and conceived under the project activity has replaced prevailing practice of using traditional cook stoves in rural areas across the state. Independent research reveals that out of 120 million of the total potential of biomass cook stove in India the total number of household using cook stoves is around 14.904 million (WHO, UNDP 2009). Study by ESMAP revealed that, improved cook stoves accounted for less than 7 percent of the total biomass stoves used in rural areas. The report also refers to the latest national survey in India highlighting the fact that only 5 percent of rural households possess an improved cook stove (Zhang et al. 2006). The study portrays Maharashtra amongst one of those few states where, improved cook stoves were distributed under the National Programme of Improved Chulha (NPIC) since 1983-84 and continued thereafter. The distribution was facilitated through Rural Development and Water Conservation Department, Maharashtra Energy Development Agency and Khadi and Village Industries Commission. Even after prolonged period of distribution since 1983, around 85% of households in the villages of Maharashtra still rely on traditional cook stoves.

It is worthwhile to note that firewood and wood chips contributes as major cooking fuel amongst rural households in India. According to the NSSO 61st round survey, a considerable percentage of rural population of Maharashtra relies upon fire wood for cooking and the percentage is substantially much higher amongst the lower MPCE (Monthly Per

Capita Expenditure) group. Since the beneficiary selected under the project belongs to BPL and ST category of population in terms of capacity of expenditure therefore, improved cook stove use will result in substantial fuel wood saving as the section is the major consumer of fuel wood.

MPCE Groups	Percentage of Population using firewood
Rs. 0 – 235/-	79.2%
Rs. 235 – 270/-	93.8%
Rs. 270 – 320/-	90.0%
Rs. 320 – 365/-	87.2%
Rs. 365 – 410/-	86.2%
Rs. 410 – 455/-	84.2%
Rs. 455 - 510/-	82.8%

The improved cook stoves distributed are more efficient with thermal efficiency of 29.88% compared to traditional stoves with thermal efficiency of around 10%. Use of efficient cook stove will result in fuel consumption reduction i.e. non-renewable biomass (since the demand of fire wood is considerably higher than the sustainable potential of fire wood extraction there the wood available through unsustainable extraction is conceived as non-renewable biomass) through minimizing of thermal energy losses by facilitating complete combustion and thereby resulting in GHG emission reduction.

Technology Employed

The cook stove deployed under the project activity is single pot, portable, metallic, improved biomass cook stoves made of cast iron for combustion of solid biomass. The improved cook stoves are manufactured in accordance to IS 13152, Part-1: 1991, CPRI Design Type I standard. The design ensures complete combustion of biomass. The cook stove is tested for thermal efficiency of 29.88% as per water boiling test protocol specified in IS 13152, Part 1: 1991.

Measures undertaken

The Rural Development and Water Conservation (RDWC) Department, Government of Maharashtra is involved in promoting betterment of living standard for the tribal household (ST) and families living below poverty line (BPL) in villages of Maharashtra. The department as a part of its aforesaid programme selects households from amongst the ST and BPL category depending upon level of vulnerability (assessed on basis of 13 parameters:

Category and size of usable land, Type of house, Availability of regular usable clothes, Protection of food or food security, Cleanliness, Ownership of required goods, Heights /Level of literacy, Family working capacity, Source of livelihood goods, Number of children in age group (5 to 14), Type of bankruptcy, reason for staying away from family of Earning member, Choice of help /Yojana) and provide financial assistance to facilitate better and hygienic living standard. The household selected for financial assistance under the programme is provided with an improved cook stove system. The household considered as end users of cook stoves under the project activity are poor enough to afford for procurement of cook stoves and are also least interested towards investment as wood is available for free. So, in absence of the cook stove the household would have continued with traditional cooking practice. Since, the project activity is conceived under the program of Govt. of Maharashtra which provides cook stove only to BPL and ST category household so there is no chance the cook stove will be distributed to non-baseline household. Therefore, identification of beneficiaries and distribution of the cook stoves comes under the preview of the Rural Development and Water Conservation Department.

The project activity plans to disseminate the improved cook stoves over period of time amongst BPL (Below Poverty Line) and Scheduled Tribes (ST) households in rural areas of Solapur district of Pune division in Maharashtra. The project is to consider beneficiaries comprising of 14,066 Nos. of household to whom improved cook stoves are to be disseminated under the programme and has signed the end user Tripartite Agreement. The project through conservation of non-renewable biomass will result in greenhouse gas emission reduction of 12,644 tCO₂e annually.

Vikram Stoves and Fabricators (hereafter referred to as Vikram Stoves) is a MNRE (Ministry of New and Renewable Energy) approved manufacturer and distributor of improved cook stoves having operation network in Maharashtra. The agency is selected by the RDWC Department, Government of Maharashtra for distribution of improved cook stoves amongst identified beneficiaries. With an objective of wide spread dissemination (under limited annual budgetary support provision of the Ministry) of improved cook stoves and facilitate continual usage at beneficiary level; the manufacturer conceived CDM in its revenue model. The revenue was conceived in deciding upon the capital cost as well as to meet up the cost towards imparting awareness and training, periodic maintenance and post lifetime replacement within the crediting period.

M/s G K Energy Marketers Pvt Ltd (hereafter referred to as GKEMPL) is authorised as Project Participant by Vikram Stoves and the end users for development of CDM project activity for the cook stove dissemination. As a part of the project activity GKEMPL (Project Participant) along with Vikram Stoves will enter into contractual agreement with the beneficiaries by virtue of which, the end user will confirm use of cook stove as well as transfer the CER right to the Project Participant.

1.2 Sectoral Scope and Project Type

The project activity falls under Sectoral Scope 3: Energy Demand

This project is not grouped project because there is no addition other project activity.

This is non-AFLOU type of project.

1.3 Project Eligibility

The project activity involves replacement of the traditional cook stoves by improved cook stoves. The improved cook stoves owing to its higher combustion efficiency of 29.88% in comparison to 10% efficiency of the traditional cook stoves results in efficiency improvement and same do not exceed equivalent of 20 Giga watt hour (GWh) (60 giga watt hour thermal (GWth))per year. Hence the project activity is eligible Sectoral scope 3 i.e. energy demand under the scope of the VCS Program.

This project activity is registered under CDM mechanism with a fixed crediting period of 01/01/2013 to 31/12/2022. The project was commissioned/started its implementation on 30/03/2010 and fixed crediting period of 10 years has been chosen for this project activity in VCS. Hence crediting period of the project activity becomes same as CDM crediting period i.e 01/01/2013 to 31/12/2022. Hence project is eligible under VCS as VCS crediting period is not breaching the CDM crediting period.

1.4 Project Design

The project activity plans to disseminate the improved cook stoves over period of time amongst BPL (Below Poverty Line) and Scheduled Tribes (ST) households in rural areas of Solapur district of Pune division in Maharashtra. The project is to consider beneficiaries comprising of 14,066 Nos. of household to whom improved cook stoves are to be disseminated under the programme and has signed the end user Tripartite Agreement

Eligibility Criteria

Not applicable to this project activity as this is not a grouped project.

1.5 Project Proponent

Organization name	M/s G K Energy Marketers Pvt. Ltd
Contact person	Mr. Gopal Kabra
Title	Authorized Signatory
Address	Lokmanya Nagar, LBS Road, Flat No.- 350, Building No.- 25,Ground Floor, Pune, Maharashtra – 411030 India
Telephone	+91 99704 50000
Email	gopal@energymarketers.in

1.6 Other Entities Involved in the Project

Organization name	EKI Energy Services Limited
Role in the project	Project Consultant
Contact person	Mr. Pankaj Rajpoot
Title	Assistant Manager- Operations
Address	Office No 201, Plot No 48, Scheme 78, Vijay Nagar Part- II, Indore 452010, India
Telephone	+91- 7828347589
Email	+91- 7828347589

1.7 Ownership

As per VCS Program Definitions version 4, the project ownership is the legal right to control and operate the project activities.

As per CDM Project Design Document section A.2, M/s. G K Energy Marketers Pvt Ltd (hereafter referred to as GKEMPL) is authorised as Project Participant by Vikram Stoves and the end users for development of VCS project activity for the cook stove dissemination. As a part of the project activity GKEMPL (Project Participant) along with Vikram Stoves will enter into contractual agreement with each beneficiaries by virtue of which the end user will confirm use of cook stove as well as transfer the CER right to the Project Participant

Based on above evidences, the project ownership is demonstrated and M/s. G K Energy Marketers Pvt Ltd is authorized project owner.

1.8 Project Start Date

30/03/2010

As per start date Definition of Start date in VCS Standard Version 04 the project which do not require construction or significant pre-project implementation (e.g. light bulb replacement)

the start date is to be considered the date when real action occurs. Therefore, Delivery of the cook stove to Rural Development Department/authorised representative is considered as the start date.

1.9 Project Crediting Period

The crediting period of the project activity is for 10 years (Fixed).

The length of the first crediting period is 01-01-2013 to 31-12-2022 (both dates inclusive).

1.10 Project Scale and Estimated GHG Emission Reductions or Removals

The project activity falls under small-scale project category since the annual average GHG emission reductions are less than 300,000 tCO₂e

Project Scale	
Project	√
Large project	

Year	Estimated GHG emission reductions or removals (tCO ₂ e)
Year 1	12,644
Year 2	12,644
Year 3	12,644
Year 4	12,644
Year 5	12,644
Year 6	12,644
Year 7	12,644
Year 8	12,644
Year 9	12,644
Year 10	12,644
Total estimated ERs	12,6440

Total number of crediting years	10
Average annual ERs	12,644

1.11 Description of the Project Activity

The improved cook stove conceived under the project activity is MNRE and BIS (Bureau of Indian Standard) approved state of art and environmentally sound technology. The improved cook stove is manufactured in accordance to IS13152 (Part 1): 1991(Solid Biomass – Chulha Part 1(Metallic)). This Indian Standard was adopted by the Bureau of Indian Standard after the draft specification was finalized by the oil burning Appliances Sectional Committee had been approved by Heavy Mechanical Engineering Division Council. There has been no transfer of technology for the project activity. The standard has been prepared in line with the national approach towards fuel conservation, better environment, mitigating health hazards and loss of forest cover caused by burning of wood as cooking fuel and therefore can be conceived as an environmentally sound technology for combustion of solid biomass for the purpose of cooking. Moreover the materials used in the manufacturing of the cook stove are of iron and steel which is recyclable after end use and hence considered to be environmentally safe after lifetime also.

The cook stove distributed under the project activity is a portable, single-pot stove without chimney, natural draft and metal made stove specifically suitable for combustion of solid biomass. The cook stove broadly comprises of a combustion chamber, top plate for holding the utensils, grate for holding fuel during combustion and bottom plate that facilitates ventilation of air. The combustion chamber is cylindrical shaped and made up of mild steel. One side of the chamber of improved cook stove is opened for feeding of fuel. The chamber top plate is die cast and made up of cast iron.

Figure 1: Diagram of Improved Cook stove

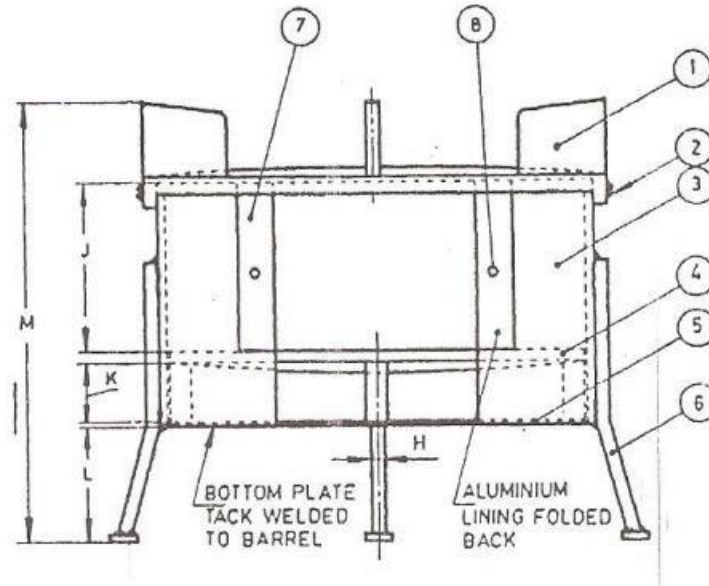

1. Top plate,
2. Screw,
3. Barrel,
4. Grate,
5. Bottom Plate,
6. Legs,
7. Aluminum Lining and
8. Rivet

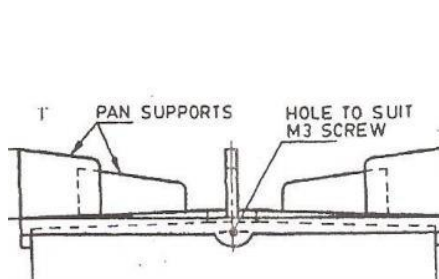
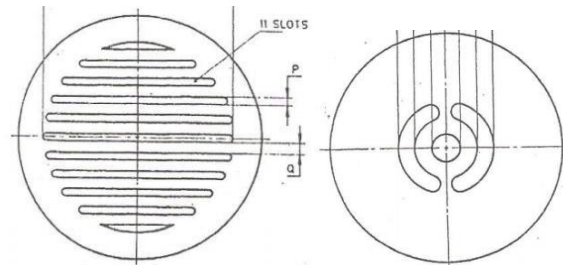

Figure 1.a. Top Plate Figure



1.b. Grate Figure 1.c. Bottom Plate

Figure 2: Improved Cook stove



Material used for manufacturing of each component of the cook stoves are:

Component	Material
Top plate	Cast iron
Grate	Cast iron
Barrel	Mild steel
Bottom Plate	Mild steel
Lining	Aluminium
Perforated Sleeve	Mild steel
Handle	Mild steel
Pan Support	Mild steel sheet-flat-rod
Legs	Mild steel sheet and rod

1.12 Project Location

The project is located in state Maharashtra, India.

The list of division is given below:

Division: Pune

Districts: Solapur

Latitude: 17.10 ON to 18.32°N

Longitude: 74.42 OE to 76.15 °E

Figure 3: Map of India



Figure 4: Map of Maharashtra

Figure 5: Map of Solapur

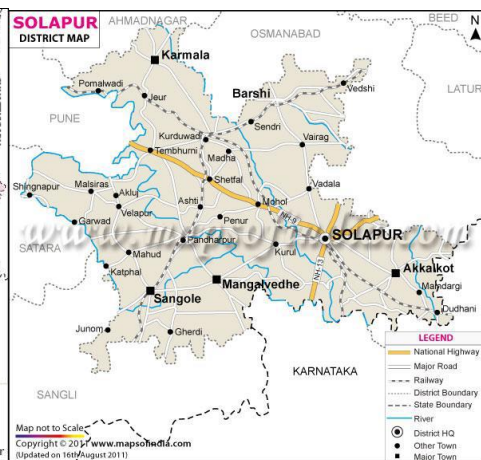
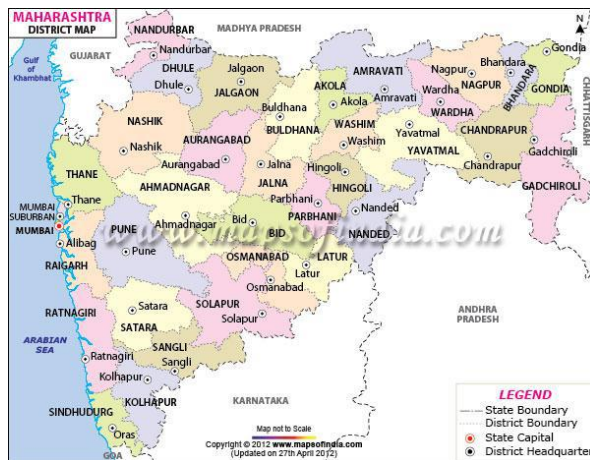

1.13 Conditions Prior to Project Initiation

The project activity involves dissemination of higher efficiency biomass fired cook stoves use as household appliances (29.88% as tested from MNRE approved Centre) for cooking purpose. This will contribute in reduction of non-renewable biomass consumption which would have been otherwise consumed by less efficient cook stoves.

Please refer to section B 4 of PDD of the UNFCCC registered CDM project with Ref No. 7958 through the web link

Web-link: <https://cdm.unfccc.int/Projects/DB/RWTUV1351686175.57/view>

1.14 Compliance with Laws, Statutes and Other Regulatory Frameworks

The Project has received all the necessary approvals for development and commissioning for the proposed project from the respective State Nodal Agencies and is in compliance to the local laws and regulations.

The Project has received necessary approvals for development and commissioning for cook stove project from the state Nodal agencies and is in compliance to the local laws and regulations.

1.15 Participation under Other GHG Programs

1.15.1 Projects Registered (or seeking registration) under Other GHG Program(s)

Project has been registration with UNFCCC under Clean Development Mechanism program, Registration reference number is 7958.

1.15.2 Projects Rejected by Other GHG Programs

The Project is not rejected by any other GHG programs.

1.16 Other Forms of Credit

1.16.1 Emissions Trading Programs and Other Binding Limits

India is Non-annex1 country and there is no compliance with an emission trading program or to meet binding limits on GHG emissions for this project activity. The project is registered under CDM with registration ID 7958. Project Proponent has submitted undertaking that they will not claim same GHG emission reductions of the project from CDM and VCS. PP would not use net GHG emission reductions by the projects for compliance with emission trading program to meet binding limits on GHG emissions. PP has also submitted an undertaking stating that they will not take REC benefits for the same Emission Reductions.

1.16.2 Other Forms of Environmental Credit

Project has been registered with UNFCCC under Clean Development Mechanism program. Registration reference number is 7958. Project Proponent has submitted undertaking for not availing other forms of environmental credit for the same crediting period under consideration. Project Participant is not taking REC benefits for the same emission reductions

1.17 Additional Information Relevant to the Project

Leakage Management

Not applicable to this project activity.

Commercially Sensitive Information

No commercially sensitive information has been excluded from the public version of the project description.

Sustainable Development

The project contribution towards sustainable development is established in line with the sustainable development indicator framed by the host country DNA:

Social benefits:

- Reduces drudgery of women and children of rural areas (due to reduced fuel wood use) by reducing time spent and distance travelled for fuel wood collection. Reduction in firewood requirement would help in spending more time in productive activities such as education, employment etc.
- Improves overall health (particularly diseases related to respiratory system) of women and children by reducing smoke in the kitchen.

Environmental benefits:

- Improves the local environment by reducing rate of forest degradation /deforestation in the project area. Conservation of forest will not only reduce non-renewable biomass demand and also reduce soil erosion and loss of biodiversity as a consequence of deforestation.

- Reduces emission of black carbon to the atmosphere.
- Reduces Green-house gas emissions.

Economic benefits:

- Employment opportunities for local communities involved in monitoring, training of users, undertaking periodic maintenance and post life time replacement.
- Reduces the expenditure involved in the pre project scenario for purchase of fuel wood.

Technological benefits:

- Introduction of new technology to the rural communities.
- Knowledge transfer to trainers including technicians for pertaining training to users, maintenance of system.
- Demonstration of a successful project at household level will create replication potential in other states and countries.

In view of the above, the project proponent considers that, the project activity profoundly contribute towards sustainable development of the region as well as of the nation.

Further Information

There are no information or incidents that will have bearing on the eligibility of the project, the net GHG emission reductions or removals, or the quantification of the project's net GHG emission reductions or removals.

2 SAFEGUARDS

2.1 No Net Harm

According to the Ministry of Environment and Forests (MoEF), Government of India, under the Environment Impact Assessment Notification vide S .O.1533(E), dated 14/09/2006; the project activity of utilization of Improved Cook stove for cooking in rural households does not require environmental impact assessment study to be carried out.

2.2 Local Stakeholder Consultation

Please refer to sections E 1 and E 2 of PDD of the UNFCCC registered CDM project with reference no. 7958.

The web link of the same is given below:

<https://cdm.unfccc.int/Projects/DB/RWTUV1351686175.57/view>

2.3 Environmental Impact

Please refer to sections D 1 of PDD of the UNFCCC registered CDM project with reference no. 7958.

The web link of the same is given below:

<https://cdm.unfccc.int/Projects/DB/RWTUV1351686175.57/view>

2.4 Public Comments

The project Description has been web-hosted. Public comments will be incorporated once the commenting period is over.

2.5 AFOLU-Specific Safeguards

Not Applicable

3 APPLICATION OF METHODOLOGY

3.1 Title and Reference of Methodology

Consolidated baseline methodology for “Energy efficiency measures in thermal applications of non-renewable biomass”; AMS II-G, Version 03.0.0 Sectoral Scope: 03, EB 60.

3.2 Applicability of Methodology

The project activity involves replacement of the traditional cook stoves by improved cook stoves. The improved cook stoves owing to its higher combustion efficiency of 29.88% in comparison to 10% efficiency of the traditional cook stoves results in efficiency improvement and same do not exceed equivalent of 20 Giga watt hour (GWh) (60 giga watt hour thermal (GWhth))per year. The project is selected for applying small scale methodologies under Type II. As the cumulative energy saving from the project activity is

less than 20 GWh/annum or 60 GWhth/annum and each of the independent sub-systems i.e. Improved cook stoves used in household only for the purpose of cooking results an estimated annual energy savings of 4.073 MWhth or 1.358 MWh (detailed calculation presented in section B.5. of the PDD) which is well smaller than permissible limit of 600 MWh. Therefore, the project is considered appropriate to be developed under micro small scale guidelines. The applicability criteria of the chosen methodology AMS-II. G (Version 03) is satisfied by the project activity in following manner:

Criteria 1

This category comprises appliances involving the efficiency improvements in the thermal applications of non-renewable biomass. Examples of these technologies and measures include the introduction of high efficiency biomass fired cook stoves or ovens or dryers and/or improvement of energy efficiency of existing biomass fired cook stoves or ovens or dryers.

Justification: The project activity involves dissemination of higher efficiency biomass fired cook stoves use as household appliances (29.88% as tested from MNRE approved centre) for cooking purpose. This will contribute in reduction of non-renewable biomass consumption which would have been otherwise consumed by less efficient cook stoves. Since, it is an introduction of high efficiency cook stove the above condition is justified.

Criteria 2:

Project participants are able to show that non-renewable biomass has been used since 31 December 1989, using survey methods or referring to published literature, official reports or statistics.

Justification: Use of non-renewable biomass is established through demonstration of gap between the demand of fire wood and silviculturally permissible production of biomass from forest and tree outside forest. The fact is established using published literature referring to the following studies:

Food and Agricultural Organisation of United Nation - Regional Wood Energy Development Programme in Asia

The literature highlights gap in demand and supply of fuel wood across the country as well as across the state of Maharashtra. In accordance to the study, fuel wood consumption in real terms is much higher than the recorded production of about 30%; thus, leaving a wide gap leading towards unsustainable extraction of fire wood. Moreover, on account of population pressure, demand for firewood has outstripped natural regeneration and planting, so much so that in some areas there is food to eat but not enough wood is available to cook it (Mathur, 1987)". The report also highlight the statistics from Forest Survey of India

(FSI1988:46) which estimated a gap of 130 million tonne between the demand and internal production of firewood in the country in 1987. The study also highlight demand for fuel-wood across Maharashtra in 1980 around 17 million cu.m.as against the production of 1.5 million cu. m. from the recorded forest (Pethiya & Luthra, 1991). The quoted demand supply gap of fire wood is also highlighted in the finding of the National Council for Applied Economic Research (NCAER).

State of Forest Report 1987, MoEF, Govt. of India

The report highlights gap between the demand and production of fire wood as major cause of deforestation. The reported consumption and production across the country within silvi culturally permissible limit across the following years is indicated as follows –

Year	Consumption in million tones	Recorded Production in million tonnes
1953-54	86.3	6.49
1960-61	99.6	8.15
1965-66	109.3	9.16
1970-71	117.9	11.62
1975-76	133.1	19 m. from forest and 30 m. from tree outside forest

In accordance the gap between demand and production is met through pilferage leading to continuous depletion of forest land.

Wood Fuel Trade in India: Food and Agricultural Organisation of United Nation

The report outlines demand- supply gap which has referred the expert committee report of MoEF dated 30.01.1998 as below –

In million cubic metre			
Year	Consumption	Sustainable Production	Gap
1953-54	115.0	8.8	106.2
1965-66	163.9	13.7	150.2
1975-76	199.6	28.5	171.4
1987-88	235.0	40.0	195.0

Rural energy data sources and estimations in India - TERI

The report refers to gap between consumption and recorded production of fuel-wood has however increasing, indicating seriousness of the fuel-wood scarcity in India.

Fuel wood consumption and sustainable production since 1947

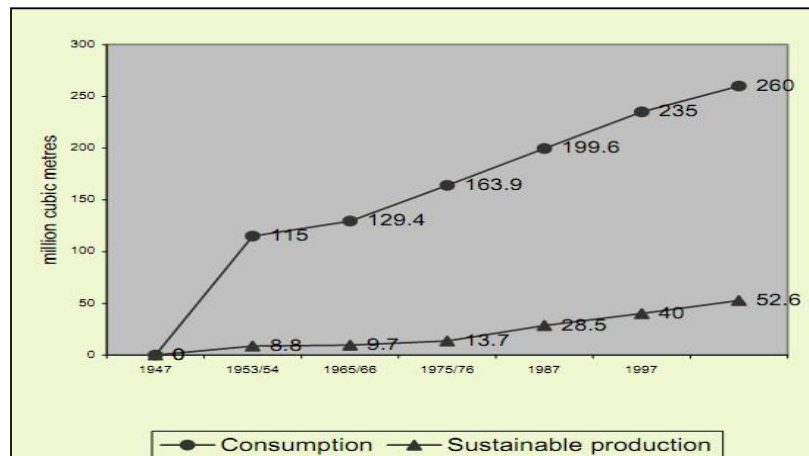

Conclusion:

Therefore, it is established from the above studies that, a staggering gap exists between the demand and potential for sustainably extractable fuel wood from forest land. While the first three studies refer to the fuel wood supply scenario and the gap that were precedent before 1989; the study by TERI highlight the widening of gap between the demand and supply of biomass after 1989. The widening of the gap has been both due to the increased population pressure as well as the conversion of dense forest to medium dense, scrub and open type forest land due to unsustainable extraction even after the government's initiative towards promotion of afforestation. Thus, it can therefore be concluded that the gap exists from and before 1989 and continued thereafter, forcing the population in using biomass extracted in un- sustainable manner which is identified as non-renewable component.

As demonstrated above, the project activity satisfies qualifying criteria of the selected methodology AMS - II.G. Hence, the choice of the methodology is justified.

3.3 Project Boundary

According to the Paragraph 3 of approved methodology AMS-II.G., "The project boundary is the physical, geographical site of the efficient systems using biomass".

The project boundary is therefore, encompasses physical, geographical sites of all 14,066 individual households possessing efficient cook stove in the district of Solapur, Pune Division, Maharashtra. Based on the methodology, GHG included for the baseline and project scenario, leakage for the project activity is CO₂.

Source		Gas	Included?	Justification/Explanation
Baseline	Emission combustion fuel wood traditional stove from of in cook	CO ₂	Yes	This is the major Green-house gas emitting from combustion of fuel wood in the baseline scenario.
		CH ₄	No	Not Applicable as per the applicable methodology
		N ₂ O	No	Not Applicable as per the applicable methodology
Project	Emission from consumption of fuel wood in efficient cook stoves	CO ₂	No	Not Applicable as per the applicable methodology
		CH ₄	No	Not Applicable as per the applicable methodology
		N ₂ O	No	Not Applicable as per the applicable methodology
Leakage Emissions	Leakage related to the use/diversion of non-renewable woody biomass saved under the project activity by non – project households/users	CO ₂	Yes	Baseline fuel wood consumption is multiplied by a net to gross adjustment factor of 0.95 to account for leakages.
		CH ₄	No	Not Applicable as per the applicable methodology
		N ₂ O	No	Not Applicable as per the applicable methodology
	Leakage related to if equipment utilised under the project activity is transferred from outside the boundary	CO ₂	No	Not Applicable as per the applicable methodology
		CH ₄	No	Not Applicable as per the applicable methodology
		N ₂ O	No	Not Applicable as per the applicable methodology

3.4 Baseline Scenario

Please refer to section B 4 of PDD of the UNFCCC registered CDM project reference no. 7958.

The web link of the same is given below:

<https://cdm.unfccc.int/Projects/DB/RWTUV1351686175.57/view>

3.5 Additionality

Please refer to section B 5 of PDD of the UNFCCC registered CDM project reference no. 7958.

The web link of the same is given below:

<https://cdm.unfccc.int/Projects/DB/RWTUV1351686175.57/view>

3.6 Methodology Deviations

Not Applicable, as there are no methodological deviations for this project activity.

4 QUANTIFICATION OF GHG EMISSION REDUCTIONS AND REMOVALS

4.1 Baseline Emissions

Please refer to section B 6.1 of PDD of the UNFCCC registered CDM project reference no. 7958.

The web link of the same is given below:

<https://cdm.unfccc.int/Projects/DB/RWTUV1351686175.57/view>

4.2 Project Emissions

Please refer to section B 6.1 of PDD of the UNFCCC registered CDM project reference no. 7958.

The web link of the same is given below:

<https://cdm.unfccc.int/Projects/DB/RWTUV1351686175.57/view>

4.3 Leakage

Please refer to section B 6.1 of PDD of the UNFCCC registered CDM project reference no. 7958.

The web link of the same is given below:

<https://cdm.unfccc.int/Projects/DB/RWTUV1351686175.57/view>

4.4 Net GHG Emission Reductions and Removals

Please refer to section B 6.4 of PDD of the UNFCCC registered CDM project reference no. 7958.

The web link of the same is given below:

<https://cdm.unfccc.int/Projects/DB/RWTUV1351686175.57/view>

Year	Estimated baseline emissions or removals (tCO ₂ e)	Estimated project emissions or removals (tCO ₂ e)	Estimated leakage emissions (tCO ₂ e)	Estimated net GHG emission reductions or removals (tCO ₂ e)
Year 1	13,310	0	666	12,644
Year 2	13,310	0	666	12,644
Year 3	13,310	0	666	12,644
Year 4	13,310	0	666	12,644
Year 5	13,310	0	666	12,644
Year 6	13,310	0	666	12,644
Year 7	13,310	0	666	12,644
Year 8	13,310	0	666	12,644
Year 9	13,310	0	666	12,644
Year 10	13,310	0	666	12,644
Total	13,3100	0	6660	12,6440

5 MONITORING

5.1 Data and Parameters Available at Validation

Please refer to section B 6.2 of PDD of the UNFCCC registered CDM project reference no. 7958.

The web link of the same is given below:

<https://cdm.unfccc.int/Projects/DB/RWTUV1351686175.57/view>

5.2 Data and Parameters Monitored

Please refer to section B 7.1 of PDD of the UNFCCC registered CDM project reference no. 7958.

The web link of the same is given below:

<https://cdm.unfccc.int/Projects/DB/RWTUV1351686175.57/view>

5.3 Monitoring Plan

Please refer to section B 7.2 of PDD of the UNFCCC registered CDM project reference no. 7958.

The web link of the same is given below:

<https://cdm.unfccc.int/Projects/DB/RWTUV1351686175.57/view>

APPENDIX

Use appendices for supporting information. Delete this appendix (title and instructions) where no appendix is required.