



**Verified Carbon
Standard**

DONGYUAN XIANTANG LANDFILL GAS POWER GENERATION PHASE I PROJECT

Document Prepared by Goldchina Consultancy International Co., Ltd.

Project Title	Dongyuan Xiantang Landfill Gas Power Generation Phase I Project
Version	01
Date of Issue	15/06/2022
Prepared By	Dr. Zhaoning Zheng Goldchina Consultancy International Co., Ltd.
Contact	Address: Room 230, Unit B, Building 2, Tangning One, No. 16 of Zhongguancun East Road, Haidian District, Beijing, China 100083 Telephone: (86) 18010121386 Fax: (8610) 6268 2682 Email: zzn@gcci-carbon.com

CONTENTS

- 1 PROJECT DETAILS 4**
 - 1.1 Summary Description of the Project 4
 - 1.2 Sectoral Scope and Project Type 4
 - 1.3 Project Eligibility 4
 - 1.4 Project Design 5
 - 1.5 Project Proponent 5
 - 1.6 Other Entities Involved in the Project 5
 - 1.7 Ownership 6
 - 1.8 Project Start Date 6
 - 1.9 Project Crediting Period 6
 - 1.10 Project Scale and Estimated GHG Emission Reductions or Removals 6
 - 1.11 Description of the Project Activity 7
 - 1.12 Project Location 8
 - 1.13 Conditions Prior to Project Initiation 90
 - 1.14 Compliance with Laws, Statutes and Other Regulatory Frameworks 10
 - 1.15 Participation under Other GHG Programs 10
 - 1.16 Other Forms of Credit 10
 - 1.17 Sustainable Development Contributions 10
 - 1.18 Additional Information Relevant to the Project 11

- 2 SAFEGUARDS 11**
 - 2.1 No Net Harm 11
 - 2.2 Local Stakeholder Consultation 12
 - 2.3 Environmental Impact 12
 - 2.4 Public Comments 13
 - 2.5 AFOLU-Specific Safeguards 13

- 3 APPLICATION OF METHODOLOGY 13**
 - 3.1 Title and Reference of Methodology 14
 - 3.2 Applicability of Methodology 14
 - 3.3 Project Boundary 21

3.4 Baseline Scenario	24
3.5 Additionality	24
3.6 Methodology Deviations	25
4 QUANTIFICATION OF GHG EMISSION REDUCTIONS AND REMOVALS	25
4.1 Baseline Emissions	25
4.2 Project Emissions	39
4.3 Leakage	41
4.4 Net GHG Emission Reductions and Removals	41
5 MONITORING	42
5.1 Data and Parameters Available at Validation	42
5.2 Data and Parameters Monitored	52
5.3 Monitoring Plan	59

1 PROJECT DETAILS

1.1 Summary Description of the Project

Dongyuan Xiantang Landfill Gas Power Generation Phase I Project (hereafter referred to as the project) is invested and owned by Shenzhen PhasCon Technologies Co., Ltd. (hereafter referred to as the project owner). The project captures the landfill gas that would have been released to the atmosphere in the absence of the project and generates electricity with the landfill gas(LFG). The electricity is supplied to the China Southern Power Grid (CSPG) to replace the electricity generated from coal-fired power plants of CSPG.

Dongyuan Xiantang landfill site is located in Hongguang Village, Xiantang Town, Dongyuan County, Heyuan City, Guangdong Province, China. The landfill site started operation in 2011 with an operational lifespan of 30 years. The landfill handles an average of 400 tonnes Municipal Solid Waste (MSW) per day which is mainly from the Dongyuan County and nearby city.

The purpose of the project is to use LFG, which consists mainly of methane, for electricity generation. It includes LFG collection system, LFG pre-treatment system and electricity generation system. The project started to construct on 22/04/2021. The total installed capacity of the project will be 4MW. The project consists of 8 sets of 500kW generators, 4 sets of them was operated since 25/01/2022. LFG collected is used for electricity generation with internal combustion generators to generate about 132,091MWh supplying to CSPG during the first 7 years crediting period. The expected average annual emission reductions are 122,015 tCO₂e and the total emission reductions are 854,102 tCO₂e during the first 7-year crediting period.

Scenario existing prior to the implementation of the project (the same as baseline scenario):

LFG from Dongyuan Xiantang landfill site is emitted to the atmosphere directly. Equivalent electricity generated by the project is provided by CSPG, which is dominated by fossil fuel-fired power stations.

1.2 Sectoral Scope and Project Type

Sectoral scope 1: energy industries(renewable-/non-renewable sources), and sectoral scope 13: Waste handling and disposal.

Project Type: Waste handling and disposal

The project is not a grouped project.

1.3 Project Eligibility

The scope of the VCS Program includes six Kyoto Protocol greenhouse gases. The project is an LFG power generation project, utilizing landfill gas (LFG), which consists mainly of methane, for electricity generation, which is eligible under the scope of the VCS program.

1.4 Project Design

- The project includes a single location or installation only
- The project includes multiple locations or project activity instances, but is not being developed as a grouped project
- The project is a grouped project

Eligibility Criteria

Not applicable.

1.5 Project Proponent

Organization name	Shenzhen PhasCon Technologies Co., Ltd.
Contact person	Tony You
Title	Vice General Manger
Address	Room 1210, Satellite Building, No. 61, High-tech Nanjiu Road, Nanshan District, Shenzhen, China 518000
Telephone	(86)-13538080705
Email	Tonyyou@iphascon.com

1.6 Other Entities Involved in the Project

Organization name	Goldchina Consultancy International Co., Ltd.
Role in the project	Consultancy
Contact person	Dr. Zheng Zhaoning
Title	Technical director

Address	Room 230, Unit B, Building 2, Tangning One, No. 16 of Zhongguancun East Road, Haidian District, Beijing, China 100083
Telephone	(86) 18010121386
Email	zzn@gcci-carbon.com

1.7 Ownership

The project owner is Shenzhen PhasCon Technologies Co., Ltd..The approval of Feasibility Study Report (FSR) and Environmental impact Assessment (EIA), and the business license of the project owner are the evidence for legislative right. Besides, the purchasing power agreement are the evidence for the ownership of the plant equipment and power generating. Shenzhen PhasCon Technologies Co., Ltd. is responsible for the acquisition of approvals, construction and operation of the project.

1.8 Project Start Date

25/01/2022 (commercial operation started date).

1.9 Project Crediting Period

7 years *3 renewable crediting period is adopted by the project activity.

The first 7 years VCS project crediting period started on 25/01/2022 and will be expired on 24/01/2029(the start and end dates included).

1.10 Project Scale and Estimated GHG Emission Reductions or Removals

The estimated annual GHG emission reductions/removals of the project are:

- <20,000 tCO₂e/year
- 20,000 – 100,000 tCO₂e/year
- 100,001 – 1,000,000 tCO₂e/year
- >1,000,000 tCO₂e/year

Project Scale	
Project	√
Large project	

Year	Estimated GHG emission
------	------------------------

	reductions or removals (tCO ₂ e)
25/01/2022-31/12/2022	70,490
2023	87,174
2024	100,649
2025	116,137
2026	133,935
2027	154,377
2028	177,870
01/01/2029-24/01/2029	13,471
Total estimated ERs	854,102
Total number of crediting years	7
Average annual ERs	122,015

1.11 Description of the Project Activity

GHG emission reductions will be achieved through combustion of the recovered LFG by gas engines, which would be otherwise emitted to the atmosphere, and the generation of electricity from the LFG is exported to CSPG to replace equivalent amount of electricity from those fossil fuel power plants connected to CSPG.

The project includes an LFG collection system, an LFG pre-treatment system, an electricity generation plant, and grid connection system.

LFG collection system

The landfill gas collecting system is a gas pipeline network, consisting of gas collecting wells, gas collecting pipelines, and gas collection blower. LFG is extracted by gas collection blower and transported by pipeline from gas collection wells.

LFG pre-treatment system

Prior to electricity generation, LFG must be pre-treated to remove its impurities and moisture, etc., to prevent corrosion in the generators. According to the EIA, the pre-treatment system consists of six types of equipment: 1) Impurity Filter to remove the impurity in LFG primarily; 2) Condenser to remove the water in LFG; 3) Gas-liquid Separator to remove the liquid in LFG

further; 4) Fan Blower to boost the LFG; 5) Heat Exchanger to cool down the gas; 6) Advanced Impurity Filter to remove the impurity thoroughly.

The LFG pre-treatment procedure and the main equipment are shown as the following chart:

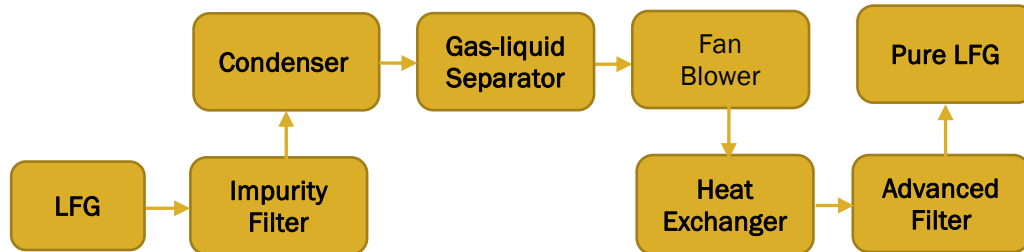

Figure 1.1 The flow chart of the LFG pre-treatment system

Power generation and grid connection system

A power plant is installed in order to generate electricity with the LFG captured. It adopts internal combustion engine generating sets. The number of engines to be installed will depend on the amount of LFG collected, but project owner foresaw to install a total capacity of 4MW. In the project, 4 sets each with capacity of 500kW has been installed for power generation and started commissioning on 25/01/2022, and the rest 4 sets will be installed before the end of 2022. The electricity generated using LFG, except small portion for on-site usage, is exported to CSPG.

This is a well-known and high reliable technology for biogas utilization. Furthermore, internal combustion engine generating sets have modular design and are available in many different sizes permitting the installation of power plant step by step as the LFG flow increases. High performance and reliability are guaranteed for the equipment.

The detailed information about the technology of the project is shown in the table below.

Table 1.1 Key technical parameters of internal combustion engine generating set

Type	Gas-fired Engine and generator
Model	500GF1-1RZ
Rated Voltage	400 V
Rated capacity	500kW
Lifetime	20 years

1.12 Project Location

The project is located in Hongguang Village, Xiantang Town, Dongyuan County, Heyuan City, Guangdong Province, China. The geographical location of the project site is shown in Figure 1.2. The central coordinates of the project location are longitude of 114°45'40" E and latitude of 23°50'45" N.



Figure 1.2 The location of the project

1.13 Conditions Prior to Project Initiation

The baseline scenarios are the same as the conditions existing prior to the project initiation. The details are showed in the Section 3.4.

1.14 Compliance with Laws, Statutes and Other Regulatory Frameworks

The project is in the field of waste handling and disposal and meets the relevant provision of the law of the People's Republic of China on the Prevention and Control of Environmental Pollution by Solid Waste, Renewable Energy Law of the People's Republic of China, National Action plan for the collection and Utilization of municipal landfill gas. The generation of power exported to CSPG will meet the requirement of national laws and regulations. Consequently, the project is compliance with laws, statutes, and other regulatory frameworks.

1.15 Participation under Other GHG Programs

1.15.1 Projects Registered (or seeking registration) under Other GHG Program(s)

The project has not been registered/or is seeking registration under other GHG Program(s).

1.15.2 Projects Rejected by Other GHG Programs

The project has not been rejected by other GHG programs.

1.16 Other Forms of Credit

1.16.1 Emissions Trading Programs and Other Binding Limits

Does the project reduce GHG emissions from activities that are included in an emissions trading program or any other mechanism that includes GHG allowance trading?

Yes No

1.16.2 Other Forms of Environmental Credit

Has the project sought or received another form of GHG-related credit, including renewable energy certificates?

Yes No

1.17 Sustainable Development Contributions

The project will contribute to sustainable development in the following sides:

Landfill safety

If methane concentration in the air is in the range of 5-15% in volume within the confined space of a building, the risk of explosion is very high. With the project, a modern gas extraction system has been installed to ensure the effective collection of LFG, and also minimize the risk of landfill explosions.

Odour reduction

Odour from landfill negatively impacts on residents around the landfill. Implementation of the project will reduce odour through LFG collection and will thus mitigate the impact of landfill odour on people's daily lives.

Energy potential

The project makes use of LFG to generate electricity, which will supplement the energy supply of Heyuan city.

Provide employment

The project was designed and technically supported by experts. Temporary job opportunities were created during the construction period and 10 permanent jobs during the operation time.

As a whole, the project will contribute to the sustainable development, not only by mitigating global warming, but also increasing the availability of electricity from renewable sources. It will also minimize the explosion risk at the landfill site and will increase job availability through the management, operation and maintenance of the LFG capture system and the power units.

1.18 Additional Information Relevant to the Project

Leakage Management

No special leakage management.

Commercially Sensitive Information

No commercially sensitive information has been excluded from the public version of the project description.

Further Information

No further information.

2 SAFEGUARDS

2.1 No Net Harm

There is no net harm.

The Environmental Impact Assessment (EIA) Report for the project was compiled by Heyuan Tianhao Environmental Technology Ltd, which is a grade A environment impact assessment

entity certified by the Ministry of Ecology and Environment, China. Combined with the EIA report, the influences of the project on the environment are summarized. The EIA Report for the Project has been approved by the Environmental Protection Bureau of Dongyuan County on 18/05/2021, with approval No. "Hedong Huanjiang [2021] No.9". According to the approval comments of the EIA Report by the Environmental Protection Bureau of Dongyuan County, the environmental impacts likely to be caused by the project are considered insignificant and conforming to the laws and regulations; therefore, there is no net harm.

2.2 Local Stakeholder Consultation

The project owner carried out a survey on the local residents and comments received from the survey are summarized as follows. The survey was conducted through distributing and collecting responses to a questionnaire.

The following questions are from the questionnaires:

1. What do you know about the LFG power station?
2. What is your attitude to the construction of this LFG power station?
3. Do you think the implementation of the project will cause positive effect on living of local residents?
4. Do you think the implementation of the project will cause negative effect?
5. As a whole, what is your opinion on this LFG power station to the living of local residents??

The project is away from the residence, so, only 10 families live around the project and the landfill site. Each family was distributed a questionnaire. In total 10 out of 10 questionnaires were returned with a 100% response rate. The survey shows the stakeholders believe that the project will have positive impacts on the local ecology and employment. All stakeholders expressed their support to the project and were pleased with the development of the project, and no negative comments have been received. The project would actually facilitate the development of the local economy and increase the income of local residents.

During project implementation phase, there is a public comments collection and feedback book for the power plant. The local stakeholders can leave their opinions, comments and concerns on the project and contact information in the public comments collection and feedback book at any time. The project owner will contact the local stakeholders to give feedback within one week. So far, no public comments about potential negative impacts during project implementation have been received by the project owner.

2.3 Environmental Impact

According to the Environmental Impact Assessment, environmental impacts possibly caused by the project and protection measures adopted by the project owner are analysed as follows:

Water Quality

The amount of wastewater which is produced by the project is very small. The condensate water during the process of landfill gas collection will be treated by the landfill leachate treatment system. The domestic wastewater from onsite employees will be treated in the septic tank and then treated by the landfill leachate treatment system.

Air Quality

This project uses LFG which is collected from Dongyuan Xiantang landfill site to generate electricity, and it avoids uncontrolled releasing of LFG. Therefore, it reduces greenhouse gas and effluvia emitting to air, and mitigates the possible danger of fire or explosion.

The emission amount of NO_x, SO₂ and NH₃ for this project is less than the national emission standards, that is because prior to electricity generation, LFG has been pre-treated to remove its impurities and moisture. After that, LFG is sent to gas-fired engines. And the exhaust gas would be emitted to atmosphere which is far away from sensitive targets. Therefore, the emission of exhaust gas has little impact on surrounding environment.

Noise

The project is surrounded by landfill site and mountains, the only building which is next to the project is Dongyuan Xiantang landfill site office building. The EIA has said that under the influence of distance attenuation, air absorption and trees blocking, the noise of the project has no impact on surrounding residential areas.

Solid Waste

This project produces small amounts of solid waste. The general industrial solid waste is dust. All solid waste will be sent to the landfill site, which could not only ensure the safety of disposal, but also has little impact on surrounding environment.

As a whole, the project was not considered that it would bring out negative environmental impacts. On the contrary, this project will promote local environment by reducing emission of greenhouse gas.

2.4 Public Comments

The Project will be listed on the Verra website for public comments.

2.5 AFOLU-Specific Safeguards

The project is not an AFOLU project.

3 APPLICATION OF METHODOLOGY

3.1 Title and Reference of Methodology

Title: Flaring or use of landfill gas -- Version 19.0

Reference: <https://cdm.unfccc.int/methodologies/PAmethodologies/approved>

The methodology also refers to the latest approved versions of the following tools:

“Combined tool to identify the baseline scenario and demonstrate additionality” (Version 07.0);

“Baseline, project and/or leakage emissions from electricity consumption and monitoring of electricity generation” (Version 03.0);

“Emissions from solid waste disposal sites” (Version 08.0);

“Tool to calculate the emission factor for an electricity system” (Version 07.0);

"Tool to determine the mass flow of a greenhouse gas in a gaseous stream"(Version 03.0);

“Positive lists of technologies” (Version 04.0).

3.2 Applicability of Methodology

The selected methodology (ACM0001, version 19.0) is appropriate to LFG project activities, where the baseline scenario is the atmospheric release of the LFG, and that all or part of the electricity exported to the grid is the electricity generation in existing and/or new grid-connected power plants. In this case, the LFG is released to atmosphere prior to the implementation of the project, electricity generated by the project is exported to China Southern Power Grid (CSPG).

According to the EIA of the project, it fulfills the following applicability conditions of the methodology ACM0001

Applicability conditions	Justifications
(a) Install a new LFG capture system in an existing or new (Greenfield) SWDS where no LFG capture system was or would have been installed prior to the implementation of the project activity; or	Applicable. The project involves the installation of a new LFG capture system in an existing SWDS.

<p>(b) Make an investment into an existing LFG capture system to increase the recovery rate or change the use of the captured LFG, provided that:</p> <p>(i) The captured LFG was vented or flared and not used prior to implementation of the project activity; and</p> <p>(ii) In the case an existing active LFG capture system for which the amount of LFG cannot be collected separately from the project system after the implementation of the project activity and its efficiency is not impacted on by the project system: historical data on the amount LFG capture and flared is available;</p>	<p>Not applicable. There wasn't an LFG capture system prior to the implement of the project.</p>
<p>(c) Flare the LFG and/or use the captured LFG in any (combination) of the following ways:</p> <p>(i) Generation electricity;</p> <p>(ii) Generation heat in a boiler, air or kiln (brick firing only) or glass melting furnace; and/or</p> <p>(iii) Supplying the LFG to consumers through a natural gas distribution network;</p> <p>(iv) Supplying compressed/liquefied LFG to consumers using trucks;</p> <p>(i) Supplying the LFG to consumers through a dedicated pipeline;</p>	<p>Applicable. The project uses the captured LFG to generate electricity, which corresponds to point(i).</p>
<p>(d) Do not reduce the amount of organic waste that would be recycled in the absence of the project.</p>	<p>The implementation of the project does not reduce the amount of organic waste that would be recycled in the absence of the project. All the solid waste is disposed in the Dongyuan Xiantang landfill site.</p>
<p>The methodology is only applicable if the application of the procedure to identify the baseline scenario confirms that the most</p>	<p>The most plausible baseline scenario of the project is:</p> <p>(1) LFG from Dongyuan Xiantang</p>

<p>plausible baseline scenario is:</p> <ul style="list-style-type: none"> (a) Atmospheric release of the LFG or captured of LFG and destruction through flaring to comply with regulations or contractual requirements, to address safety and odour concerns, or for other reasons; and (b) In the case that the LFG is used in the project activity for generation electricity and/or generating heat in a boiler, air heater, glass melting furnace or kiln: <ul style="list-style-type: none"> (i) For electricity generation: that electricity would be generated in the grid or in captive fossil fuel fired power plants; and/or (ii) For heat generation: that heat would be generated using fossil fuels in equipment located within the project boundary. (c) In the case of LFG supplied to the end-user(s) through natural gas distribution network, trucks or the dedicated pipeline, the baseline scenario is assumed to be displacement of the natural gas. (d) In the case of LFG from a Greenfield SWDS, the identified baseline scenario is atmospheric release of the LFG or captured of LFG in a managed SWDS and destruction through flaring to comply with regulations or contractual requirements, to address safety and odour concerns, or for other reasons. 	<p>landfill site is emitted to the atmosphere directly.</p> <p>(2) Equivalent electricity generated by the project is supplied by the China Southern Power Grid (CSPG).</p>
---	---

<p>The methodology is not applicable:</p> <p>(a) In combination with other approved methodologies. For instance, ACM0001 cannot be used to claim emission reductions for the displacement of fossil fuels in a kiln or glass melting furnace, where the purpose of the CDM project activity is to implement energy efficiency measures at a kiln or glass melting furnace;</p> <p>(b) If the management of the SWDS in the project activity is deliberately changed during the crediting in order to increase methane generation compared to the situation prior to the implementation of the project activity.</p>	<p>Not applicable.</p>
---	------------------------

Regarding to tool— “Baseline, project and/or leakage emissions from electricity consumption and monitoring of electricity generation”

Applicable conditions	Justifications
<p>a. If emissions are calculated for electricity consumption, the tool is only applicable if one out of the following three scenarios applied to the sources of the electricity consumption:</p> <p>b. Scenario A: Electricity consumption from the grid. The electricity is purchased from the grid only, and either no captive power plant(s) is/are installed at the site of electricity consumption or, if any captive power plant exists on site, it is either not operating or it is not physically able to provide electricity to the electricity consume;</p> <p>c. Scenario B: Electricity consumption from (an) off-grid fossil fuel fired captive power</p>	<p>Scenario A is applicable for the project. The project purchases electricity from the grid during the operation. There is no captive power plant(s) at the site of the project.</p>

<p>plant(s). One or more fossil fuel fired captive power plants are installed at the site of the electricity consume and supply the consumer with electricity. The captive power plant(s) is/are not connected to the electricity grid;or</p> <p>d. Scenario C: Electricity consumption from the grid and (a) fossil fuel fired captive power plant(s). One or more fossil fuel fired captive power plants operate at the site of the electricity consumer. The captive power plant(s) can provide electricity consumer. The captive power plant(s) is/are also connected to the electricity grid. Hence, the electricity consumer can be provided with electricity from the captive power plant(s) and the grid.</p>	
<p>Scenario A is applicable for the project. The project purchases electricity from the grid during the operation. There is no captive power plant(s) at the site of the project.</p>	<p>Not applicable.</p>

Regarding to tool— “Tool to calculate the emission factor for an electricity system” (Version 07.0):

Applicable conditions	Justifications
<p>This tool may be applied to estimate the OM, BM and/or CM when calculating baseline emissions for a project activity that substitutes grid electricity that is where a project activity supplies electricity to a grid or a project activity that results in savings of electricity that would have been provided by the grid (e.g. demand-side energy efficiency projects).</p>	<p>Applicable. This tool is applied to estimate the OM, BM and/or CM.</p>

<p>Under this tool, the emission factor for the project electricity system can be calculated either for grid power plants only or, as an option, can include off-grid power plants. In the latter case, two sub-options under the step 2 of the tool are available to the project participants, i.e. option IIa and option IIb. If option IIa is chosen, the conditions specified in “Appendix 1: Procedures related to off-grid power generation” should be met. Namely, the total capacity of off-grid power plants (in MW) should be at least 10 per cent of the total capacity of grid power plants in the electricity system; or the total electricity generation by off-grid power plants (in MWh) should be at least 10 per cent of the total electricity generation by grid power plants in the electricity system; and that factors which negatively affect the reliability and stability of the grid are primarily due to constraints in generation and not to other aspects such as transmission capacity.</p>	<p>Applicable. The emission factor for the project electricity system is calculated for grid power plants only.</p>
<p>In case of CDM projects the tool is not applicable if the project electricity system is located partially or totally in an Annex I country.</p>	<p>Not applicable. The project electricity system is located in China.</p>
<p>Under this tool, the value applied to the CO₂ emission factor of biofuel is zero.</p>	<p>Not applicable.</p>

Regarding to tool— “Tool to determine the mass flow of a greenhouse gas in a gaseous stream” (Version 03.0):

Applicable conditions	Justifications
-----------------------	----------------

<p>Typical applications of this tool are methodologies where the flow and composition of residual or flared gases or exhaust gases are measured for the determination of baseline or project emissions.</p>	<p>Applicable. This tool is applied to determination of baseline emissions by measuring the combusted LFG.</p>
<p>Methodologies where CO₂ is the particular and only gas of interest should continue to adopt material balances as the means of flow determination and may not adopt this tool as material balances are the cost effective way of monitoring flow of CO₂.</p>	<p>Not applicable.</p>
<p>The underlying methodology should specify:</p> <ul style="list-style-type: none"> (a) The gaseous stream the tool should be applied to; (b) For which greenhouse gases the mass flow should be determined; (c) In which time intervals the flow of the gaseous stream should be measured; and (d) Situations where the simplification offered for calculating the molecular mass of the gaseous stream (equations (3) or (17)) is not valid (such as the gaseous stream is predominantly composed of a gas other than N₂) 	<p>Applicable.</p> <p>The gaseous stream determined the baseline emissions is LFG which mainly contains fraction of CH₄, which corresponds to point (a) and (b).</p> <p>LFG combusted by the engines is measured continuously by a flow meter and recorded hourly, which corresponds to point (c).</p> <p>Point (d) is not applicable.</p>

Regarding to tool— “Positive lists of technologies” (Version 04.0):

Applicable conditions	Justifications
<p>The use of this methodological tool is not mandatory for the project participants of a CDM project activity or CDM POA for demonstrating their additionality.</p>	<p>Applicable.</p>

<p>This methodological tool shall be applied in conjunction with a small-scale or large-scale methodology which refers to this tool.</p>	<p>Applicable. This tool is applied in conjunction with large-scale methodology ACM0001 (version 19.0)</p>
--	--

Regarding to tool— “Emissions from solid waste disposal sites” (Version 08.0):

<p>(a) Application A: The CDM project activity mitigates methane emissions from a specific existing SWDS. Methane emissions are mitigated by capturing and flaring or combusting the methane (e.g. "ACM0001: Flaring or use of landfill gas). The methane is generated from waste disposed in the past, including prior to the start of the CDM project activity. In these cases, the tool is only applied for an ex ante estimation of emissions in the project design document (CDM-PDD). The emissions will then be monitored during the crediting period using the applicable approaches in the relevant methodologies (e. g. measuring the amount of methane captured from the SWDS).</p>	<p>Applicable. The project collects the methane from the Dongyuan Xiantang landfill site and use it to generate the electricity.</p>
<p>(b) Application B: The CDM project activity avoids or involves the disposal of waste at a SWDS. An example of this application of the tool is ACM0022, in which municipal solid waste (MSW) is treated with an alternative option, such as composting or anaerobic digestion, and is then prevented from being disposed of in a SWDS. The methane is generated from waste disposed or avoided from disposal during the crediting period. In these cases, the tool can be applied for both ex ante and ex post estimation of emissions. These project activities may apply the simplified approach detailed in 0 when calculating baseline emissions.</p>	<p>Not applicable.</p>

3.3 Project Boundary

The project boundary is the site of the project activity where the gas is captured and destroyed.

The Project Activity boundary consists of the whole LFG related system, including LFG collection, and LFG power generation system, auxiliary equipment, etc. The project baseline boundary includes all the facilities in the landfill except the LFG system, as well as all grid-connected power plants in China Southern Power Grid which provides the electricity to the landfill. China Southern Power Grid consists of five provinces, i.e. Guangdong, Guangxi, Yunnan, Guizhou and Hainan. The project boundary is shown in figure 3.1.

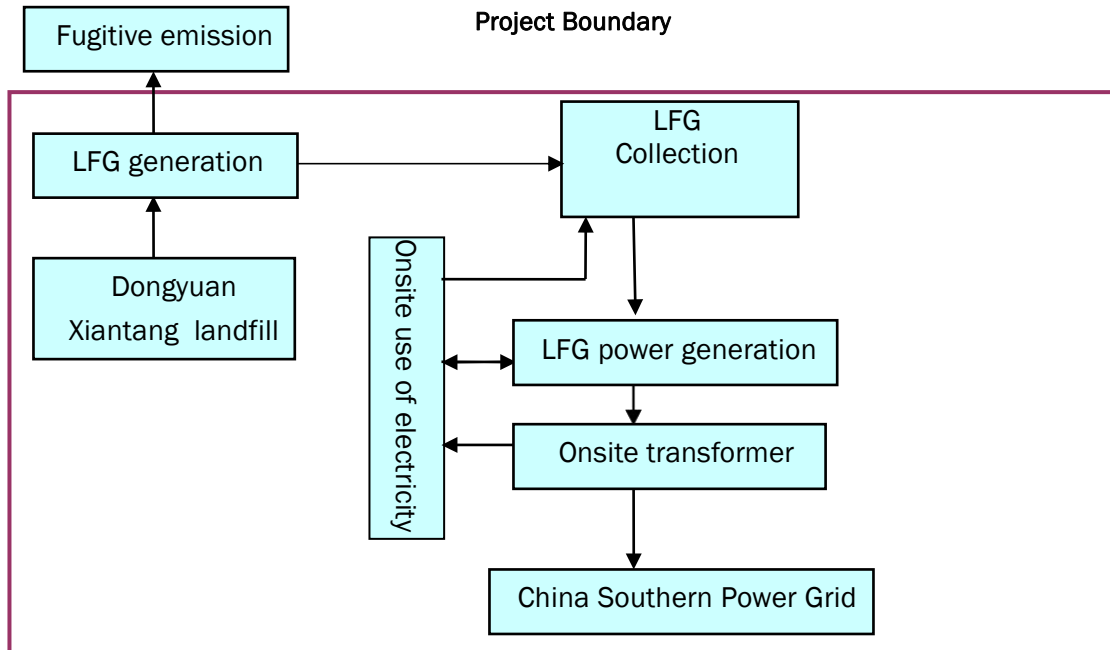

Figure 3.1 the Diagram of Project Boundary

Table 3.1 Summary of greenhouse gases and sources included in and excluded from the project boundary

Source	Gas	Included?	Justification/Explanation
Baseline Emissions from decomposition of waste at the SWDS site	CO ₂	No	CO ₂ emissions from the decomposition of organic waste are not accounted since the CO ₂ is also released under the project activity.
	CH ₄	Yes	The major source of emissions in the baseline.
	N ₂ O	No	N ₂ O emissions are small compared to CH ₄ emissions from landfills. Exclusion of this

Source	Gas	Included?	Justification/Explanation
			gas is conservative.
	Other	-	
Emission from electricity generation	CO ₂	Yes	The major source of emissions in the baseline.
	CH ₄	No	Excluded for simplification, this is conservative.
	N ₂ O	No	Excluded for simplification, this is conservative.
	Other	-	
Emissions from fossil fuel consumption for purposes other than electricity generation or transportation due to the project activity	CO ₂	No	Excluded because there is no fossil fuel consumption.
	CH ₄	No	Excluded because there is no fossil fuel consumption.
	N ₂ O	No	Excluded because there is no fossil fuel consumption.
	Other	-	
Emissions from electricity consumption due to the project activity	CO ₂	Yes	Main emission source.
	CH ₄	No	Excluded for simplification. This emission source is very small compared to CO ₂ emissions.
	N ₂ O	No	Excluded for simplification. This emission source is very small compared to CO ₂ emissions.
	Other	-	

Table 3.2. The geographic coordinates of the Dongyuan Xiantang LFG project.

Landfill	Location	Longitude	Latitude
----------	----------	-----------	----------

Dongyuan Xiantang Landfill	Hongguang Village, Xiantang town, Dongyuan County	114° 45'40"E	23° 50'45" N
----------------------------	---	--------------	--------------

3.4 Baseline Scenario

According to the section 5.3.1 of the methodology ACM0001, the project chooses simplified procedures to identify the baseline scenario.

The LFG from Dongyuan Xiantang landfill site is vented to the atmosphere prior the implementation of the project for safety concerns, and the majority electricity generated by the LFG will be exported to the China Southern Power Grid (CSPG), and a little of which is consumed by the project.

Therefore, the baseline scenario is:

LFG from Dongyuan Xiantang landfill site is emitted to the atmosphere directly.

Equivalent electricity generated by the project is supplied by the CSPG, which is dominated by fossil fuel-based power plants.

3.5 Additionality

According to the section 5.3.1 of the methodology ACM0001, the project chooses simplified procedures to demonstrate additionality. Tool 32 (Positive lists of technologies) is used to demonstrate additionality.

Requirements of tool 32 (Positive lists of technologies)	The project
<p>5.1Waste handling and disposal</p> <p>5.1.1Landfill gas recovery and its gainful use</p> <p>The project activities and PoAs at new or existing landfills (greenfield or brownfield) are deemed automatically additional if it is demonstrated that prior to the implementation of the project activities and PoAs the LFG was only vented and or flared (in the case of brownfield projects) or would have been only vented and/or flared (in the case of greenfield projects) but not utilized for energy generation, and that under the project activities and PoAs any of the following conditions are met:</p> <p>(a) The LFG is used to generate electricity in</p>	<p>The LFG from Dongyuan Xiantang landfill site is vented to the atmosphere prior the implementation of the project for safety concerns.</p> <p>Total nameplate capacity of the project is 4MW, which is below 10MW.</p>

<p>one or several power plants with a total nameplate capacity that equals or is below 10 MW;</p> <p>(b) The LFG is used to generate heat for internal or external consumption</p> <p>(c) The LFG is flared</p>	
---	--

Conclusion: the project is automatically additional.

3.6 Methodology Deviations

There is no methodology deviation.

4 QUANTIFICATION OF GHG EMISSION REDUCTIONS AND REMOVALS

4.1 Baseline Emissions

The project utilizes the LFG for generation to substitute the equivalent electricity supplied by the grid, resulting in CH₄ and CO₂ emissions, which will be calculated as follows according to the methodology ACM0001(version 19.0):

$$BE_y = BE_{CH_4,y} + BE_{EC,y} + BE_{HG,y} + BE_{NG,y} \quad \text{Equation (1)}$$

Where:

BE_y = Baseline emissions in year y (t CO₂e/yr)

$BE_{CH_4,y}$ = Baseline emissions of methane from the SWDS in year y (t CO₂e/yr)

$BE_{EC,y}$ = Baseline emissions associated with electricity generation in year y (t CO₂/yr)

$BE_{HG,y}$ = Baseline emissions associated with heat generation in year y (t CO₂/yr)

$BE_{NG,y}$ = Baseline emissions associated with natural gas use in year y (t CO₂/yr)

The project doesn't involve heat and natural gas. $BE_{HG,y}=0, BE_{NG,y}=0$. Therefore:

$$BE_y = BE_{CH_4,y} + BE_{EC,y} \quad \text{Equation (2)}$$

Step A: Baseline emissions of methane from the SWDS ($BE_{CH_4,y}$)

$$BE_{CH_4} = \left((1 - OX_{top_layer}) \times F_{CH_4,PJ,y} - F_{CH,BL,y} \right) \times GWP_{CH_4} \quad \text{Equation (3)}$$

Where:

- $BE_{CH_4,y}$ = Baseline emissions of methane from the SWDS in year y (t CO₂e/yr)
- OX_{top_layer} = Fraction of methane in the LFG that would be oxidized in the top layer of the SWDS in the baseline (dimensionless)
- $F_{CH_4,PJ,y}$ = Amount of methane in the LFG which is flared and/or used in the project activity in year y (t CH₄/yr)
- $F_{CH_4,BL,y}$ = Amount of methane in the LFG that would be flared in the baseline in year y (t CH₄/yr)
- GWP_{CH_4} = Global warming potential of CH₄ (t CO₂e/t CH₄)

Step A1: Ex post determination of $F_{CH_4,PJ,y}$

During the crediting period, $F_{CH_4,PJ,y}$ is determined as the sum of the quantities of methane flared and used in power plant(s), boiler(s), air heater(s), glass melting furnace(s), kiln(s) and natural gas distribution, as follows:

$$F_{CH_4,PJ,y} = F_{CH_4,flared,y} + F_{CH_4,EL,y} + F_{CH_4,HG,y} + F_{CH_4,NG,y} \quad \text{Equation (4)}$$

Where:

- $F_{CH_4,PJ,y}$ = Amount of methane in the LFG which is flared and/or used in the project activity in year y (t CH₄/yr)
- $F_{CH_4,flared,y}$ = Amount of methane in the LFG which is destroyed by flaring in year y (t CH₄/yr)

$F_{CH_4, EL, y}$ = Amount of methane in the LFG which is used for electricity generation in year y (t CH₄/yr)

$F_{CH_4, HG, y}$ = Amount of methane in the LFG which is used for heat generation in year y (t CH₄/yr)

$F_{CH_4, NG, y}$ = Amount of methane in the LFG which is sent to the natural gas distribution network and/or dedicated pipeline and/or to the trucks in year y (t CH₄/yr)

The working hours of the power plant(s), boiler(s), air heater(s) and kiln(s) should be monitored, and no emission reduction should be claimed for methane destruction during non-working hours.

The project utilizes the LFG only for power generation. Therefore:

$$F_{CH_4, PJ, y} = F_{CH_4, EL, y} \quad \text{Equation (5)}$$

$F_{CH_4, EL, y}$ is determined using the “Tool to determine the mass flow of a greenhouse gas in a gaseous stream”. The following requirements apply:

- (a) As per the gaseous stream tool, if the LFG is used for multiple purposes (e.g. flaring or energy generation), and all methane destruction devices are verified to be operational (e.g. by means of flame detectors records, energy generated), a single flow meter may be used to record the flow into multiple destruction devices. The destruction efficiency of the least efficient among the destruction devices shall be used as the destruction efficiency for all destruction devices monitored by this flow meter. If there are any periods for which one or more destruction devices are not operational, paragraph 5 (a) and (b) of the Appendix of the "Tool to determine the mass flow of a greenhouse gas in a gaseous stream" tool shall be followed;
- (b) CH₄ is the greenhouse gas for which the mass flow should be determined;
- (c) The simplification offered for calculating the molecular mass of the gaseous stream is valid (equations (3) or (17) in the tool);
- (d) The mass flow should be calculated on an hourly basis for each hour h in year y ;
- (e) The mass flow calculated for hour h is 0 if the equipment is not working in hour h ($O_{pj, h}$ =not working), the hourly values are then summed to a yearly unit basis.

Amount of the methane used for power generation ($F_{CH_4, EL, y}$)

The “Tool to determine the mass of a greenhouse gas in a gaseous stream” provides following 6 options for measuring mass flow of a greenhouse gas i in a gaseous stream.

Table 4.1 Measurement options

Option	Flow of gaseous stream	Volumetric Fraction
A	Volume flow-dry basis	Dry or wet basis
B	Volume flow-wet basis	Dry basis
C	Volume flow-wet basis	Wet basis
D	Mass flow- dry basis	Dry or wet basis
E	Mass flow-wet basis	Dry basis
F	Mass flow-wet basis	Wet basis

In the gas stream, only CH₄ is the greenhouse. Therefore $F_{i,t} = F_{CH_4,EL,y}$.

The flow meter and gas analyzer are installed by the project participant to monitor the volumetric flow of the LFG and the volumetric fraction of CH₄ in the LFG, with both parameters monitored on a dry basis. Therefore, Option A of the “tool to determine the mass of a greenhouse gas in a gaseous stream” will be applied in the project. In addition, if in a particular interval it cannot be demonstrated that the gaseous stream is dry, then the flow measurement shall be assumed to be on a wet basis and the corresponding option from the table 2 showed in the “tool to determine the mass of a greenhouse gas in a gaseous stream” should be applied instead.

Option A

Option A is applicable where the volumetric flow of the LFG is measured on a dry basis. In order to demonstrate that the LFG gaseous stream is dry, the project participants shall:

- (a) Measure the moisture content of the gaseous stream ($C_{H_2O,t,db,n}$) and demonstrate that this is less or equal to 0.05 kg H₂O/m³ dry gas; or
- (b) Demonstrate that the temperature of the gaseous stream (T_t) is less than 60°C (331.15K) at the flow measurement point.

According to the daily records of the LFG treatment system, the temperature of the gaseous stream (T_t) is less than 60°C (331.15 K) at the flow measurement point, therefore method (b) is chosen.

The mass flow of CH₄ shall be determined as follows:

$$F_{i,t} = V_{t,db} \times v_{i,t,db} \times \rho_{i,t} \quad \text{Equation (6)}$$

$$\rho_{i,t} = \frac{P_t \times MM_i}{R_u \times T_t} \quad \text{Equation (7)}$$

Where:

$F_{i,t}$ = Mass flow of greenhouse gas i in the gaseous stream in time interval t (kg gas/h)

$V_{t,db}$ = Volumetric flow of the gaseous stream in time interval t on a dry basis (m³dry gas/h)

$v_{i,t,db}$ = Volumetric fraction of greenhouse gas i in the gaseous stream in a time interval t on a dry basis (m³gas i/m³drygas)

$\rho_{i,t}$ = Density of greenhouse gas i in the gaseous stream in time interval t (kg gas i/m³dry gas)

P_t = Absolute pressure of the gaseous stream in time interval t (101,325 Pa)

MM_i = Molecular mass of greenhouse gas i (16.04 kg/kmol)

R_u = Universal ideal gases constant (8,314 Pa.m³/kmol.k)

T_t = Temperature of the gaseous stream in time interval t (273.15K)

All parameters about the LFG which is fed into the gas engines are converted automatically to normal conditions during the monitoring process. Therefore, P_t and T_t don't need to be monitored.

Step A.1.1: Ex ante estimation of $F_{CH_4,PJ,y}$

An ex ante estimate of $F_{CH_4,PJ,y}$ is required to estimate baseline emission of methane from the SWDS (according to equation (3)) in order to estimate the emission reductions of the project activity in the project description. It is determined as follows:

$$F_{CH_4,PJ,y} = \eta_{PJ} \times BE_{CH_4,SWDS,y} / GWP_{CH_4} \quad \text{Equation (8)}$$

Where:

- $F_{CH_4,PJ,y}$ = Amount of methane in the LFG which is flared and/or used in the project activity in year y (t CH₄/yr)
- $BE_{CH_4,SWDS,y}$ = Amount of methane in the LFG that is generated from the SWDS in the baseline scenario in year y (t CO₂e/yr)
- η_{PJ} = Efficiency of the LFG capture system that will be installed in the project activity
- GWP_{CH_4} = Global warming potential of CH₄ (t CO₂e/t CH₄)

$BE_{CH_4,SWDS,y}$ is determined using the methodological tool “Emissions from solid waste disposal sites”. The following guidance should be taken into account when applying the tool:

f_y in the tool shall be assigned a value of 0 because the amount of LFG that would have been captured and destroyed is already accounted for in equation 2 of this methodology;

In the tool, x begins with the year that the SWDS started receiving wastes (e.g. the first year of SWDS operation); and

Sampling to determine the fractions of different waste types is not necessary because the waste composition can be obtained from previous studies.

$BE_{CH_4,SWDS,y}$ is determined using the methodological tool “Emissions from solid waste disposal sites”. For the project, the amount of methane generated from disposal of waste at the SWDS for year y ($BE_{CH_4,SWDS,y}$) is calculated using first order decay (FOD) model as follows:

$$BE_{CH_4,SWDS,y} = \varphi_y \times (1 - f_y) \times GWP_{CH_4} \times (1 - OX) \times \frac{16}{12} \times F \times DOC_{f,y} \times MCF_y \times \sum_{X=1}^Y \sum_J (W_{j,x} \times DOC_j \times e^{-kj \times (y-x)} \times (1 - e^{kj}))$$

Equation(9)

$BE_{CH_4,SWDS,y}$ = Baseline methane emissions occurring in the year y

φ_y = Model correction factor to account for model uncertainties for year y

f_y = Fraction of methane captured at the SWDS and flared, combusted or used in another manner that prevents the emission of methane to the atmosphere in year y

GWP_{CH_4} = Global Warming Potential of methane

OX	= Oxidation factor (reflecting the amount of methane from SWDS that is oxidized in the soil or other material covering the waste)	
F	= Fraction of methane in the SWDS gas (volume fraction)	
$DOC_{f,y}$	= Fraction of degradable organic carbon (DOC) that decomposes under the specific conditions occurring in the SWDS in year y (weight fraction)	
MCF_y	= Methane correction factor for year y	
$W_{j,x}$	= Amount of solid waste type j disposed or prevented from disposal in the SWDS in the year x	t
DOC_j	= Fraction of degradable organic carbon in the waste type j (weight fraction)	
k_j	= Decay rate for waste type j	1/yr
j	= Type of residual waste or types of waste in the MSW	
x	= As per ACM0001 ver 19.0, x begins with the year that the SWDS started receiving wastes (e.g. the first year of SWDS operation). x runs from the first year of landfill operation ($x=1$) to the year for which emission are calculated ($x=y$)	
y	= Year of the crediting period for which methane emissions are calculated (y is a consecutive period of 12 months)	

Step A.2: Determination of $F_{CH_4,BL,y}$

This section provides a procedure to determine the amount of methane that would have been captured and destroyed (by flaring) in the baseline due to regulatory or contractual requirements, to address safety and odour concerns, or for other reasons (collectively referred to as requirement in this section). The four cases in Table 4.2 are distinguished. The appropriate case should be identified, and the corresponding instructions followed.

Table 4.2 Cases for determining methane captured and destroyed in the baseline

Situation at the start of the project activity	Requirement to destroy methane	Existing LFG capture and destruction system
Case 1	No	No
Case 2	Yes	No
Case 3	No	Yes

Case 4	Yes	Yes
--------	-----	-----

There was no regulation or standard that enforces methane destruction in LFG when Dongyuan Xiantang landfill site began operating. Besides, Dongyuan Xiantang landfill site didn't collect and utilize the LFG prior to the implementation of the project activity, and no LFG capture and destruction system existing. Therefore, the project is satisfied with the situation of Case 1: No requirement to destroy methane exists and no existing LFG capture system.

In this situation:

$$F_{CH_4, BL, y} = 0 \quad \text{Equation (10)}$$

Step: B Baseline emissions associated with electricity generation ($BE_{EC,y}$)

The baseline emissions associated with electricity generation in year y ($BE_{EC,y}$) shall be calculated using the "Methodological tool: Baseline, project and/or leakage emissions from electricity consumption and monitoring of electricity generation".

$$BE_{EC,y} = EC_{BL,k,y} \times EF_{EF,k,y} \times (1 + TDL_{k,y}) \quad \text{Equation(11)}$$

Where:

$BE_{EC,y}$ = Baseline emission from electricity consumption in year y (tCO₂/yr)

$EC_{BL,k,y}$ = Quantity of electricity that would be consumed by the baseline electricity consumer k in year y (MWh/yr)

$EF_{EF,k,y}$ = Emission factor for electricity generation for source k in year y (t CO₂/MWh)

$TDL_{k,y}$ = Average technical transmission and distribution losses for providing electricity to source k in year y

k = Sources of electricity consumption in the baseline

When applying the tool:

- (a) The electricity sources k in the tool correspond to the sources of electricity generated identified in the selection of the most plausible baseline scenario; and
- (b) $EC_{BL,k,y}$ in the tool is equivalent to the net amount of electricity generated using LFG in year y ($EG_{PJ,y}$).

According to the tool “Baseline, project and/or leakage emissions from electricity consumption and monitoring of electricity generation” (version 03.0), the project belongs to the case of Scenario A. A default value of $TDL_{k,y} = 3\%$ is used for baseline emission.

Determination of the emission factor for electricity generation ($EF_{EF,k,y}$)

Scenario A of the tool “Baseline, project and/or leakage emissions from electricity consumption and monitoring of electricity generation” is applicable for the project for the electricity is purchased from the grid only, and either no captive power plant is installed at the site of electricity consumption.

According to the tool “Baseline, project and/or leakage emissions from electricity consumption and monitoring of electricity generation”, $EF_{EF,k,y}$ is calculated using the “Tool to calculate the emission factor for an electricity system” ($EF_{EF,k,y} = EF_{grid,CM,y}$).

Details of the calculations and data follow the published data from the Chinese DNA¹, which uses official national statistics.

Project participants shall apply the following six steps:

- Step 1:** Identify the relevant electricity systems;
- Step 2:** Choose whether to include off-grid power plants in the project electricity system (optional)
- Step 3:** Select a method to determine the operating margin (OM);
- Step 4:** Calculate the operating margin emission factor according to the selected method;
- Step 5:** Calculate the build margin (BM) emission factor;
- Step 6:** Calculate the combined margin (CM) emission factor.

Step 1: Identify the relevant electricity systems

Ministry of Ecology and Environment of the People’s Republic of China has published a delineation of the project electricity system and connected electricity systems, so the project adopt the delineation of project electricity system and connected electricity system published by Ministry of Ecology and Environment of the People’s Republic of China. The power generated by the project displaces the equivalent electricity generated by the China Southern Power Grid.

¹ <http://www.mee.gov.cn/ywgz/ydqhbh/wsqtz/202012/W020201229610353340851.pdf>

In addition, there is net imported power to China Southern Power Grid from the East China Power Grid. According to the “Tool to calculate the emission factor for an electricity system”, use one of the following options to determine the CO₂ emission factor for net electricity imports from a connected electricity system:

- (a) 0 tCO₂/MWh; or
- (b) The simple operating margin emission rate of the exporting grid, determined as described in Step 4 section 6.4.1, if the conditions for this method, as described in Step 3 below, apply to the exporting grid;or
- (c) The simple adjusted operating margin emission rate of the exporting grid, determined as described in Step 4 section 6.4.2 below;or
- (d) The weighted average operating margin (OM) emission rate of the exporting grid, determined as described in Step 4 section 6.4.4below.

The PD will choose option (b) to calculate the CO₂ emission factor for net electricity imports for the China southern Power Grid.

According to the available data of 2015-2017, the corresponding marginal emission factors of electricity are calculated, and weighted average is carried out to obtain the marginal emission factors of electricity.

Step 2. Choose whether to include off-grid power plants in the project electricity system (optional).

Option I: Only grid power plants are included in the calculation.

Option II: Both grid power plants and off-grid power plants are included in the calculation.

Following the calculation of the Ministry of Ecology and Environment of the People’s Republic of China, and statistical data is available, Option I is chosen.

Step 3. Select a method to determine the operating margin (OM)

“Tool to calculate the emission factor for an electricity system (Version 7.0)” offers four methods for the calculation of the operating margin emission factor(s)(EF_{grid,OM,y}):

- (a) Simple OM;or
- (b) Simple adjusted OM;or
- (c) Dispatch data analysis OM;or
- (d) Average OM.

Method (a) Simple OM is chosen for calculation and low-cost/must-run resources constitute less than 50% of the total grid generation in average of the five most recent years².

For simple OM, the emission factor can be calculated using either of the two following data vintages:

(a) Ex ante option: If the ex-ante option is chosen, the emission factor is determined once at the validation stage, thus no monitoring and recalculation of the mission factor during the crediting period is required. For grid power plants, use a 3-year generation-weighted average, based on the most recent data available at the time of submission of the CDM-PDD to the DOE for validation. For off-grid power plants, use a single calendar year within the 5 most recent calendar years prior to the time of submission of the CDM-PDD for validation;

(b) Ex post option: If the ex post option is chosen, the emission factor is determined for the year in which the project activity displaces grid electricity, requiring the emissions factor to be updated annually during monitoring. If the data required to calculate the emission factor for year y is usually only available later than six months after the end of year y, alternatively the emission factor of the previous year y-1 may be used. If the data is usually only available 18 months after the end of year y, the emission factor of the year proceeding the previous year y-2 may be used. The same data vintage (y, y-1 or y-2) should be used throughout all crediting periods.

Project participant employs ex ante option for its operation margin calculation.

Step 4. Calculate the operating margin emission factor according to the selected method

The simple OM emission factor is calculated as the generation-weighted average CO₂ emissions per unit net electricity generation (tCO₂/MWh) of all generating power plants serving the system, not including low-cost / must-run power plants / units.

The simple OM may be calculated by one of the following two options:

- (a) Option A: Based on the net electricity generation and a CO₂ emission factor of each power unit; or
- (b) Option B: Based on the total net electricity generation of all power plants serving the system and the fuel types and total fuel consumption of the project electricity system. Option B can only be used if:

- (i) The necessary data for Option A is not available:and

² China Electric Power Yearbook 2014-2018, the average of the five most recent years from year 2013 to 2017 is 46.91%.

- (ii) Only nuclear and renewable power generation are considered as low-cost/must-run power sources and the quantity of electricity supplied to the grid by these sources is known; and
- (iii) Off-grid power plants are not included in the calculation (i.e., if Option I has been chosen in Step2).

Since the data of each power plant/unit is unavailable, Option A is not applicable to the project. The project adopts Option B to calculate the operating margin emission factor ($EF_{grid,OM,y}$) of CSPG as follows:

$$EF_{grid,OM,y} = \frac{\sum_i (FC_{i,y} \cdot NCV_{i,y} \cdot EF_{CO_2,i,y})}{EG_y} \quad \text{Equation (12)}$$

$EF_{grid,OM,y}$ = Simple operating margin CO₂ emission factor in year y (tCO₂/MWh) in the relevant electricity systems

$FC_{i,y}$ = Amount of fuel type i consumed in the project electricity system in year y (mass or volume unit)

$NCV_{i,y}$ = Net calorific value (energy content) of fuel type i in year y (GJ/mass or volume unit)

$EF_{CO_2,i,y}$ = CO₂ emission factor of fuel type i in year y (tCO₂/GJ)

EG_y = Net electricity generated and delivered to the grid by all power sources serving the system, not including low-cost/must-run power plants/units, in year y (MWh)

i = All fuel types combusted in power sources in the project electricity system in year y

y = The relevant year as per the data vintage chosen in Step 3.

Based on the data available, the three-year average operating margin emission factor is calculated as a full-generation-weighted average of the emission factors. Details of the calculations and data follow the published data from the Chinese DNA, which uses official national statistics. According to the latest data from the Ministry of Ecology and Environment of China, the operating margin emission factor for 2015, 2016 and 2017 are calculated based on the data above. The three-year average is calculated as a weighted

average of the emission factors. The Operational Margin Emission Factor is 0.8042 tCO₂/MWh for CSCG³.

Step 5. Calculate the build margin emission factor

In terms of vintage of data, project participants can choose between one of the following two options:

Option 1: For the first crediting period, calculate the build margin emission factor ex ante based on the most recent information available on units already built for sample group m at the time of CDM PDD submission to the DOE for validation. For the second crediting period, the build margin emission factor should be updated based on the most recent information available on units already built at the time of submission of the request for renewal of the crediting period to the DOE. For the third crediting period, the build margin emission factor calculated for the second crediting period should be used. This option does not require monitoring the emission factor during the crediting period.

Option 2: For the first crediting period, the build margin emission factor shall be updated annually, ex-post, including those units built up to the year of registration of the project activity or, if information up to the year of registration is not yet available, including those units built up to the latest year for which information is available. For the second crediting period, the build margin emissions factor shall be calculated ex ante, as described in Option 1 above. For the third crediting period, the build margin emission factor calculated for the second crediting period should be used.

The project applies option 1 to calculate the build margin emission factor ex-ante.

According to the “Tool to calculate the emission factor for an electricity system”, the sample group of power units m used to calculate the build margin should be determined as per the following procedure, consistent with the data vintage selected above:

(a) Identify the set of five power units, excluding power units registered as CDM project activities, that started to supply electricity to the grid most recently (SET_{5-units}) and determine their annual electricity generation (AEG_{SET-5-units}, in MWh);

(b) Determine the annual electricity generation of the project electricity system, excluding power units registered as CDM project activities (AEG_{total}, in MWh). Identify the set of power units, excluding power units registered as CDM project activities, that started to supply electricity to the grid most recently and that comprise 20% of AEG_{total} (if 20% falls on part of the generation of a unit, the generation of that unit is fully

³ <http://www.mee.gov.cn/ywgz/ydqhbh/wsqtzk/202012/W020201229610353340851.pdf>

included in the calculation) ($SET_{\geq 20\%}$) and determine their annual electricity generation ($AEG_{SET_{\geq 20\%}}$, in MWh);

(c) From $SET_{5-units}$ and $SET_{\geq 20\%}$ select the set of power units that comprises the larger annual electricity generation (SET_{sample});

Identify the date when the power units in SET_{sample} started to supply electricity to the grid. If none of the power units in SET_{sample} started to supply electricity to the grid more than 10 years ago, then use SET_{sample} to calculate the build margin. In this case, ignore steps (d), (e) and (f).

Otherwise:

(d) Exclude from SET_{sample} the power units which started to supply electricity to the grid more than 10 years ago. Include in that set the power units registered as CDM project activity, starting with power units that started to supply electricity to the grid most recently, until the electricity generation of the new set comprises 20% of the annual electricity generation of the project electricity system (if 20% falls on part of the generation of a unit, the generation of that unit is fully included in the calculation) to the extent is possible. Determine for the resulting set ($SET_{sample-CDM}$) the annual electricity generation ($AEG_{SET_{sample-CDM}}$, in MWh);

If the annual electricity generation of that set comprises at least 20% of the annual electricity generation of the project electricity system (i.e. $AEG_{SET_{sample-CDM}} \geq 0.2 \times AEG_{total}$), then use the sample group $SET_{sample-CDM}$ to calculate the build margin. Ignore steps (e) and (f).

Otherwise:

- (e) Include in the sample group $SET_{sample-CDM}$ the power units that started to supply electricity to the grid more than 10 years ago until the electricity generation of the new set comprises 20% of the annual electricity generation of the project electricity system (if 20% falls on part of the generation of a unit, the generation of that unit is fully included in the calculation);
- (f) The sample group of power units m used to calculate the build margin is the resulting set ($SET_{sample-CDM \rightarrow 10yrs}$).

The build margin emissions factor is the generation-weighted average emission factor (tCO_2/MWh) of all power units m during the most recent year y for which power generation data is available, calculated as follows:

$$EF_{grid, BM, y} = \frac{\sum_m (EG_{m, y} \times EF_{EL, m, y})}{\sum_m EG_{m, y}} \quad \text{Equation (13)}$$

Where:

- $EF_{grid,BM,y}$ = Build margin CO₂ emission factor in year y (tCO₂/MWh).
- $EG_{m,y}$ = Net quantity of electricity generated and delivered to the grid by power unit m in year y (MWh).
- $EF_{EL,m,y}$ = CO₂ emission factor of power unit m in year y (tCO₂/MWh).
- m = Power units included in the build margin.
- y = Most recent historical year for which power generation data is available.

Following all the steps above, the build margin emission factor, $EF_{grid,BM,y}$ of the CSPG is calculated to be 0.2135 tCO₂/MWh from the data of the Ministry of Ecology and Environment of China⁴.

Step 6. Calculate the combined margin emission factor

Combined Margin emission factor ($EF_{grid,CM,y}$) is calculated as the weighted average of the operating margin emission factor ($EF_{grid,OM,y}$) and the build margin emission factor ($EF_{grid,BM,y}$), where the weights ω_{OM} and ω_{BM} , by default, are 0.5 and 0.5 in the first crediting period, and $EF_{grid,OM,y}$ and $EF_{grid,BM,y}$ are calculated as described above and are expressed in tCO₂/MWh.

$$EF_{grid,CM,y} = \omega_{OM} \times EF_{grid,OM,y} + \omega_{BM} \times EF_{grid,BM,y} \quad \text{Equation(14)}$$

Where,

- $EF_{grid,BM,y}$ = Build margin CO₂ emission factor in year y (tCO₂/MWh)
- $EF_{grid,OM,y}$ = Operating margin CO₂ emission factor in year y (tCO₂/MWh)
- ω_{OM} = Weighting of operating margin emissions factor (%)
- ω_{BM} = Weighting of build margin emissions factor (%)

$$EF_{grid,CM,y} = 0.5 \times 0.8042 + 0.5 \times 0.2135 = 0.50885 \text{ (tCO}_2\text{/MWh)}$$

The $EF_{OM,y}$, $EF_{BM,y}$ and $EF_{grid,CM,y}$ are ex-ante calculation and are fixed during the credit period.

4.2 Project Emissions

Considering when electricity generators will be under regular maintenance and sometimes shut down, the electricity will be purchased from the SCPG during this period of time. Therefore, there will be project emissions, which is calculated following the latest version of "Tool to calculate baseline, project and/or leakage emissions from electricity consumption".

⁴<http://www.mee.gov.cn/ywgz/ydqhbh/wsqtgz/202012/W020201229610353340851.pdf>

Project emissions are calculated as follows:

$$PE_y = PE_{EC,y} + PE_{FC,y} + PE_{DT,y} + PE_{SP,y} \quad \text{Equation (15)}$$

Where:

- PE_y = Project emissions in year y (t CO₂/yr)
- $PE_{EC,y}$ = Emissions from consumption of electricity due to the project activity in year y (t CO₂/yr)
- $PE_{FC,y}$ = Emissions from consumption of fossil fuels due to the project activity, for purpose other than electricity generation, in year y (t CO₂/yr)
- $PE_{DT,y}$ = Emissions from the distribution of compressed/liquefied LFG using trucks, in year y (t CO₂/yr)
- $PE_{SP,y}$ = Emissions from the supply of LFG to consumers through a dedicated pipeline, in year y (t CO₂/yr)

The project does not include any activities consuming fossil fuels except electricity generation, so $PE_{FC,y}$ will be 0. The project does not involve the distribution of compressed/liquefied LFG using trucks and supply of LFG to consumers through a dedicated pipeline, Therefore, $PE_{FC,y}$, $PE_{DT,y}$, $PE_{SP,y}$ will be 0. Hence, PE_y is the same with $PE_{EC,y}$.

$PE_{EC,y}$ is determined by “Tool to calculate baseline, project and/or leakage emissions from electricity consumption” as follow:

$$PE_{EC,y} = \sum_j EC_{PJ,j,y} * EF_{EL,j,y} * (1+TDL_{j,y}) \quad \text{Equation (16)}$$

Where:

$PE_{EC,y}$ =Project emissions from electricity consumption in year y (tCO₂/yr)

$EC_{PJ,j,y}$ =Quantity of electricity consumed by the project electricity consumption source j in year y(MWh/yr)

$EF_{EL,j,y}$ =Emission factor for electricity generation for source j in year y(tCO₂/MWh)

$TDL_{j,y}$ =Average technical transmission and distribution losses for providing electricity to source j in year y

The “Tool to calculate baseline, project and/or leakage emissions from electricity consumption” provides 3 scenarios for different sources of electricity consumption. Since the electricity generated through the project is consumed solely from grid (CSPG), scenario A is applicable. In the case of applying scenario A, two options are available for determining emission factor. For this project, Option A1 ($EF_{EL,j,y}=EF_{grid,CM,y}$) is chosen. A default values of $TDL_{j,y}=20\%$ is used for project emission.

For simplification, $PE_{EC,y}$ will be 0 in the ex-ante calculation and will be monitored ex post in the verification period.

4.3 Leakage

No leakage effects are accounted for under this methodology.

4.4 Net GHG Emission Reductions and Removals

Emission reductions are calculated as follows:

$$ER_y = BE_y - PE_y \quad \text{Equation (17)}$$

Where,

ER_y = Emission reductions in year y (t CO₂e/yr)

BE_y = Baseline emissions in year y (t CO₂e/yr)

PE_y = Project emissions in year y (t CO₂e/yr)

Year	Estimated baseline emissions or removals (tCO ₂ e)	Estimated project emissions or removals (tCO ₂ e)	Estimated leakage emissions (tCO ₂ e)	Estimated net GHG emission reductions or removals (tCO ₂ e)
25/01/2022-31/12/2022	64,776	0	0	64,776
2023	80,108	0	0	80,108
2024	92,491	0	0	92,491
2025	106,723	0	0	106,723
2026	123,079	0	0	123,079

2027	141,863	0	0	141,863
2028	163,452	0	0	163,452
01/01/2029- 24/01/2029	12,379	0	0	12,379
Total	784,871	0	0	784,871

5 MONITORING

5.1 Data and Parameters Available at Validation

Data / Parameter	OXtop_layer
Data unit	-
Description	Fraction of methane that would be oxidized in the top layer of the SWDS in the baseline
Source of data	"Emission from the solid waste disposal sites" (version 8.0)
Value applied	0.1
Justification of choice of data or description of measurement methods and procedures applied	-
Purpose of Data	Calculation of baseline emissions
Comments	-

Data / Parameter	GWPC _{CH4}
Data unit	tCO ₂ e/t CH ₄
Description	Global warming potential of CH ₄
Source of data	IPCC
Value applied	Default value of 28. Shall be updated according to any future COP/CMP decisions

Justification of choice of data or description of measurement methods and procedures applied	-
Purpose of Data	Calculation of baseline emissions
Comments	-

Data / Parameter	ρ_{CH_4}
Data unit	t/m ³
Description	Density of methane gas at Normal Conditions
Source of data	-
Value applied	0.0007168 (Normal Conditions:0°C and101.325kPa)
Justification of choice of data or description of measurement methods and procedures applied	-
Purpose of Data	Calculation of baseline emissions
Comments	-

Data / Parameter	η_{PJ}
Data unit	-
Description	Efficiency of the LFG capture system that was installed in the project activity
Source of data	FSR of the project
Value applied	90%
Justification of choice of data or description of measurement methods and procedures applied	-

Purpose of Data	Calculation of baseline emissions
Comments	-

Data / Parameter	Φ_y
Data unit	-
Description	The model correction factor to account for model uncertainties
Source of data	Default value of the tool “Emissions from solid waste disposal sites” (version 08.0)
Value applied	0.75
Justification of choice of data or description of measurement methods and procedures applied	Application A is used to decide the value. And the value of wet conditions used for the project since the MAP/PET>1.
Purpose of Data	-
Comments	-

Data / Parameter	f_y
Data unit	-
Description	Fraction of methane captured at the SWDS and flared, combusted or used in another manner that prevents the emissions of methane to the atmosphere in year y
Source of data	The tool “Emissions from solid waste disposal sites” (version 08.0)
Value applied	0
Justification of choice of data or description of measurement methods and procedures applied	It has been considered in the section 4.1, equation (9). Therefore, $f_y=0$
Purpose of Data	
Comments	-

Data / Parameter	OX
Data unit	-
Description	Oxidation factor
Source of data	Based on an extensive review of published literature on this subject, including the IPCC2006 Guidelines for National Greenhouse Gas Inventories.
Value applied	0.1
Justification of choice of data or description of measurement methods and procedures applied	-
Purpose of Data	Calculation of baseline emissions
Comments	-

Data / Parameter	F
Data unit	-
Description	Fraction of methane in the SWDS gas (volume fraction)
Source of data	IPCC 2006 Guidelines for National Greenhouse Gas Inventories
Value applied	0.5
Justification of choice of data or description of measurement methods and procedures applied	-
Purpose of Data	Calculation of baseline emissions
Comments	-

Data / Parameter	$DOC_{r,y}$
Data unit	Weight fraction
Description	Default value for the fraction of degradable organic carbon (DOC) in MSW that decomposed in the SWDS
Source of data	IPCC 2006 Guidelines for National Green house Gas Inventories
Value applied	0.5
Justification of choice of data or description of measurement methods and procedures applied	-
Purpose of Data	Calculation of baseline emissions
Comments	-

Data / Parameter	MCF_y
Data unit	-
Description	Methane correction factor
Source of data	IPCC 2006 Guidelines for National Greenhouse Gas Inventories
Value applied	1.0
Justification of choice of data or description of measurement methods and procedures applied	The project using application A to decide the value of MCF_y . The Dongyuan Xiantang landfill site has controlled placement of waste, mechanical compacting and levelling of the waste, So MCF_y value of 1.0 for anaerobic managed solid waste disposal sites should be applied in line with "Emissions from solid waste disposal sites" (version 8.0)
Purpose of Data	Calculation of baseline emissions
Comments	-

Data / Parameter	W _x	
Data unit	t	
Description	Quantity of MSW land filled during 2011-2033	
Source of data	Records from landfill operator and calculated ex ante	
Value applied	Year	Annual landfilled MSW (tons)
	2011	6,300
	2012	41,200
	2013	45,300
	2014	49,800
	2015	54,800
	2016	60,300
	2017	66,300
	2018	72,900
	2019	83,800
	2020	96,400
	2021	110,800
	2022	127,500
	2023	146,600
	2024	168,600
	2025	193,890
	2026	222,974
	2027	256,420
	2028	294,882
	2029	339,115
	2030	389,982
	2031	448,479

	2032	515,751
	2033	593,114
	Waste type j	Weight Fraction (% wet waste)
	W1-Wood and wood products	7.13
	W2-Pulp, paper and cardboard	5.74
	W3-Food, food waste, beverages and tobacco	42.95
	W4-Textiles	2.73
	W5-Garden, yard and park waste	9.46
	W6-Glass, plastic, metal	31.99
Justification of choice of data or description of measurement methods and procedures applied	The data FSR of the project.	
Purpose of Data	Calculation of baseline emissions	
Comments	-	
Data / Parameter	DOC _j	
Data unit	-	
Description	Fraction of degradable organic carbon in the waste type j(weight fraction)	
Source of data	"Emissions from solid waste disposal sites" (version08.0)	

Value applied ²⁴	Waste type j	DOC _{j} (% wet waste)
	Wood and wood products	43
	pulp, paper and cardboard (other than sludge)	40
	Textile	24
	Food and food waste	15
	Garden, yard and park waste	20
	Glass, plastic, metal, other inert waste	0
Justification of choice of data or description of measurement methods and procedures applied	The climate condition of Dongyuan Xiantang landfill: Temperature:21.5°C Mean annual precipitation:1811 mm Potential evapotranspiration:1276 mm	
Purpose of Data	Calculation of baseline emissions	
Comments	-	
Data / Parameter	k_j	
Data unit	1/yr	
Description	Decay rate for the waste type j	
Source of data	"Emissions from solid waste disposal sites" (version08.0)	

Value applied	Waste type j		k_j (MAT>20°C, MAP/PET>1)
	Slowly degrading	Pulp, paper, cardboard(other than sludge),textile	0.07
		Wood, wood products andstraw	0.035
	Moderately degrading	Other(non- food)organic putrescible garden and park waste	0.17
	Rapidly degrading	Food, food waste, sewage sludge, beveragesand tobacco	0.40
Justification of choice of data or description of measurement methods and procedures applied	The climate condition of Dongyuan Xiantang landfill: MAT (Mean annual Temperature):21.5°C MAP (Mean annual precipitation):1811 mm PET (Potential evapotranspiration):1276 mm		
Purpose of Data	Calculation of baseline emissions		
Comments	-		

Data / Parameter	$EF_{grid,OM,y}$
Data unit	tCO ₂ /MWh
Description	Operation margin emission factor of CSPG
Source of data	2019 China baseline emission factor of regional power grid.
Value applied	0.8042
Justification of choice of	The value is published by Ministry of Ecology and Environment of

data or description of measurement methods and procedures applied	the People's Republic of China, based on China Electric Yearbook (2016-2018), Electricity Industry Statistics(2015- 2017),China Energy Statistic Yearbook(2016-2018) and IPCC data.
Purpose of Data	Calculation of baseline emissions
Comments	-

Data / Parameter	$EF_{grid, BM, y}$
Data unit	tCO ₂ /MWh
Description	Build margin emission factor of CSPG
Source of data	2019 China baseline emission factor of regional power grid.
Value applied	0.2135
Justification of choice of data or description of measurement methods and procedures applied	The value is published by Ministry of Ecology and Environment of the People's Republic of China, based on China Electric Yearbook (2014-2018), Electricity Industry Statistics (2015- 2017), China Energy Statistic Yearbook (2016-2018) and IPCC data.
Purpose of Data	Calculation of baseline emissions
Comments	-

Data / Parameter	$TDL_{j,y}$ and $TDL_{k,y}$
Data unit	%
Description	Average technical transmission and distribution losses for providing electricity to source j,k in year y
Source of data	Baseline, project and/or leakage emissions from electricity consumption and monitoring of electricity generation (version 03.0).
Value applied	Use as default values of 20% for project consumption sources; Use as default values of 3% for baseline electricity consumption sources. i.e.: $TDL_{j,y} = 3\%$, $TDL_{k,y} = 20\%$
Justification of choice of data or description of	-

measurement methods and procedures applied	
Purpose of Data	-
Comments	-

5.2 Data and Parameters Monitored

Data / Parameter	$F_{CH_4, BL, R, y}$
Data unit	tCH ₄ /y
Description	Amount of methane in the LFG which is flared due to a requirement in year y
Source of data	Information of the host country's regulatory requirements relating to LFG, contractual requirements, or requirements to address safety and odour concerns.
Description of measurement methods and procedures to be applied	-
Frequency of monitoring/recording	Annually
Value applied	0
Monitoring equipment	-
QA/QC procedures to be applied	-
Purpose of data	Calculation of baseline emissions
Calculation method	-
Comments	Applicable to Case 1 of section 5.4.1.3 of ACM0001 "Flaring or use of landfill gas" (version 19.0)

Data / Parameter	$P_{reg,y}$
Data unit	Dimensionless
Description	Fraction of LFG that is required to be flared due to a requirement in year y
Source of data	Information of the host country's regulatory requirements relating to LFG, contractual requirements, or requirements to address safety and odour concerns.
Description of measurement methods and procedures to be applied	-
Frequency of monitoring/recording	Annually
Value applied	0
Monitoring equipment	-
QA/QC procedures to be applied	-
Purpose of data	Calculation of baseline emissions
Calculation method	-
Comments	Applicable to Case 1 of section 5.4.1.3 of ACM0001 "Flaring or use of landfill gas" (version 19.0)

Data / Parameter	$EGPJ,y$
Data unit	MWh
Description	Amount of electricity generated using LFG by the project activity in year y
Source of data	Project participant

Description of measurement methods and procedures to be applied	Measured continuously by electricity meter(bi-directional) installed at the project site. All data will be monitored and archived electronically. Double check by receipt of electricity sales.
Frequency of monitoring/recording	The recording frequency will be hourly measured and record, and monthly aggregated.
Value applied	
Monitoring equipment	Electricity meter E shown in the monitoring system as below.
QA/QC procedures to be applied	The calibration should be done once a year by a qualified third party.
Purpose of data	Calculation of baseline emissions
Calculation method	
Comments	

Data / Parameter	EGEC,y
Data unit	MWh
Description	Amount of electricity consumed by the project activity in year y
Source of data	Project participant
Description of measurement methods and procedures to be applied	Measured continuously by electricity meter(bi-directional) installed at the project site. All data will be monitored and archived electronically. Double check by receipt of electricity sales.
Frequency of monitoring/recording	The recording frequency will be hourly measured and record, and monthly aggregated.
Value applied	
Monitoring equipment	Electricity meter E shown in the monitoring system as below.
QA/QC procedures to be applied	The calibration should be done once a year by a qualified third party.

Purpose of data	Calculation of baseline emissions
Calculation method	
Comments	

Data / Parameter	$V_{t,db}$
Data unit	m ³ dry gas/h
Description	Volumetric flow of the gaseous stream in time interval t on a dry basis
Source of data	Monitored by project participant
Description of measurement methods and procedures to be applied	Volume flow measurement always refer to the actual pressure and temperature.
Frequency of monitoring/recording	Measured continuously by a flow meter F (average hourly value should be used in the calculations of baseline emission reductions). Data to be aggregated monthly.
Value applied	
Monitoring equipment	Flow meter
QA/QC procedures to be applied	Flow meter should be subject to a regular maintenance and testing regime to ensure accuracy
Purpose of data	Calculation of project emissions
Calculation method	
Comments	

Data / Parameter	$V_{i,t,db}$
Data unit	m ³ dry gas/h
Description	Volumetric fraction of greenhouse gas I in a time interval t on dry basis
Source of data	Monitored by project participant
Description of measurement methods and procedures to be applied	Continuous gas analyzer operating in operating in dry-basis. Volumetric flow measurement should always refer to the actual pressure and temperature.
Frequency of monitoring/recording	Continuous if not specified in the underlying methodology
Value applied	50% (ex ante calculation)
Monitoring equipment	Gas analyzer
QA/QC procedures to be applied	Gas analyzer should be subject to a regular maintenance and testing regime to ensure accuracy
Purpose of data	Calculation of baseline emissions
Calculation method	
Comments	

Data / Parameter	Management of SWDS
Data unit	-
Description	Management of SWDS
Source of data	Use different sources of data: (a) Original design of the landfill; (b) Technical specifications for the management of the SWDS; (c) Local or national regulations

Description of measurement methods and procedures to be applied	-
Frequency of monitoring/recording	Annually
Value applied	
Monitoring equipment	
QA/QC procedures to be applied	
Purpose of data	
Calculation method	
Comments	

Data / Parameter	$Op_{j,h}$
Data unit	-
Description	Operation of the equipment that consumes the LFG
Source of data	Project participant
Description of measurement methods and procedures to be applied	The captured LFG is consumed by gas generators. Operation of the gas generators is automatically monitored and recorded in the daily records.
Frequency of monitoring/recording	Hourly
Value applied	
Monitoring equipment	
QA/QC procedures to be applied	

Purpose of data	
Calculation method	
Comments	

Data / Parameter	CAPEX and OPEX
Data unit	CNY
Description	Total investment to implement the project and total cost to operate the project
Source of data	Engineering, procurement and construction contracts; and maintenance contracts
Description of measurement methods and procedures to be applied	-
Frequency of monitoring/recording	At the first issuance request after each phase of the project is fully implemented
Value applied	-
Monitoring equipment	-
QA/QC procedures to be applied	Audited by professional, independent financial auditors. The Designated Operational Entity (DOE) should only verify that the data provided corresponds to the data from independent financial auditors
Purpose of data	
Calculation method	
Comments	

Data / Parameter	Tariff of electricity exported
Data unit	CNY
Description	Tariff of the electricity exported
Source of data	Power purchase agreement
Description of measurement methods and procedures to be applied	-
Frequency of monitoring/recording	At the first issuance request after each phase of the project is fully implemented
Value applied	-
Monitoring equipment	-
QA/QC procedures to be applied	Audited by professional, independent financial auditors. The Designated Operational Entity (DOE) should only verify that the data provided corresponds to the data from independent financial auditors.
Purpose of data	
Calculation method	
Comments	

5.3 Monitoring Plan

1. The requirement of monitoring plan

According to the “Monitoring Methodology ACM0001(Version 19.0)”, the project participants will monitor the emission reductions (ERs) by methods, indicators, and frequency to ensure project ERs are measurable and real. The monitoring methodology is based on direct measurement of the amount of LFG captured and destroyed by the project and electricity generating units.

2. Responsibilities of operational and management structure

The project participant will implement this monitoring plan. The plan could be revised according to suggestions from Designated Operational Entity (DOE) and the practical

circumstances, in order to keep it consistent, transparent and conservative during the monitoring process.

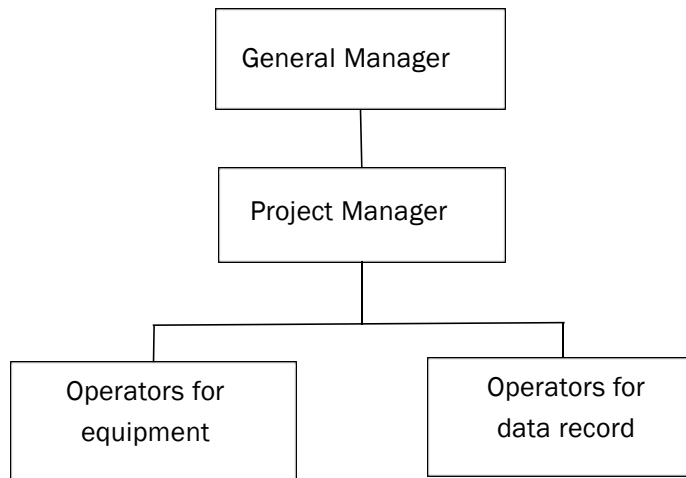

Figure 5.1 Operational and management structure

(1) Principal of the monitoring procedure

The general manager of the project is the leader of the monitoring tasks who sets out the responsibility of everyone in the monitoring system, and establishes the related documents. The general manager ensures that staffs in the monitoring system has the ability to deal with the assigned tasks.

The Project manager will be responsible for aggregating the monitored data monthly and yearly, archiving and keeping data during the crediting period and two years after.

Operators will be in charge of data supervision, checking and inspecting the system. If necessary, they will have the responsibility for executing the emergency plan and drafting emergency situation reports.

(2) Executive person of the monitoring procedure

Project Manager: A Project Manager is appointed who is specifically responsible for training, checking the daily operation, reporting forms and archiving emergency situation reports. The Project Manager reports monthly to the General Manager (GM) about the project performance and monitored data. In the event that non-conformance in the performance to the mentioned procedures and/or functioning problems of the monitoring equipment are identified, the Project manager will inform the GM about the situation and work out relevant measures to be taken. The Project manager will also be responsible for aggregating the monitored data monthly and yearly, archiving and keeping data during the crediting period and two years after.

(3) Operators of the monitoring procedure

Operators will take turns to work in the control center 24 hours a day, 7 days a week. They will be in charge of data supervision, filling operation report forms and, checking and inspecting the system. If necessary, they will have the responsibility for executing the emergency plan and drafting emergency situation reports.

3. Monitoring system

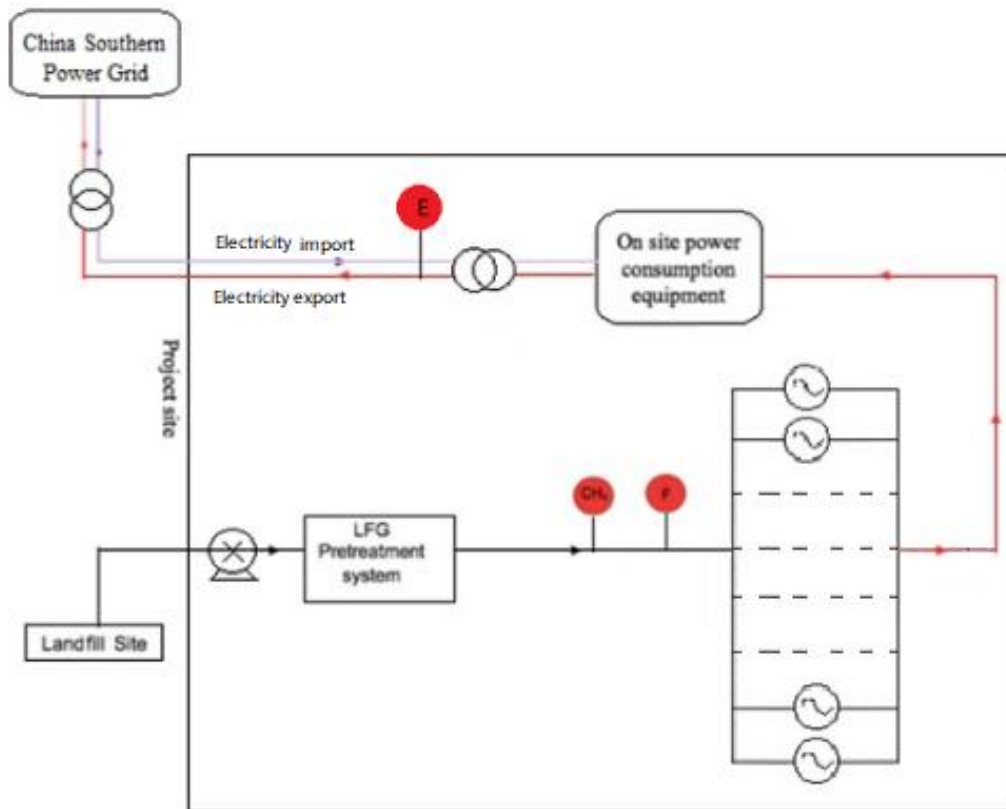

Figure 5.2 The monitoring flow chart

CH₄ - Gas analyzer to continuously measure methane fraction in LFG

F - Flow meter to continuously measure flow of LFG fed to the Power Plant

E - Bi-directional electricity meter to continuously measure the net electricity exported to CSPG and electricity imported from CSPG

QA/QC

All the monitoring devices listed above (flow meter, gas analyzer and electricity meter) will be chosen in accordance with VCS requirements and will be calibrated regularly for accuracy by qualified party according to the national regulations.

According to the Chinese national standard (Technical Management Code for Electricity Metering, DL/T448-2016), the electricity meter was properly configured and checked by both the project owner and the grid company before the project is in operation. The accuracy should not be less than 0.5%. The installation of flow meters and gas analyzers will fulfill the national standard (JJG1029-2007 and JJG693-2011).

To assist in future verification, the calibration records, along with the data files of project monitoring will be kept in the archives by the project owner, and checked by Project Manager. When the data is not available from the main monitoring devices, the data measured by the back-up devices will be used.

Data Management

Specific staff will be appointed by the project owner to take the overall responsibility for monitoring GHG emission reductions and keeping all monitored data collected as part of monitoring archived electronically and be kept at least for 2 years after the end of the last crediting period.

Electronic data and documents will be regularly copied and archived via hard disk, and kept at least two years after the end of the last crediting period.

All written data and documents, including electricity receipts for cross-checking, will be copied and archived and kept at least two years after the end of the last crediting period.

Procedure in case of failure

In the case of a meter in fault, it shall be immediately repaired or replaced with another calibrated meter by a professional engineer, and the LFG or electricity generated during the period of erroneous measurement and replacement of the fault meter shall not be accounted for conservative consideration.