



**CLEAN DEVELOPMENT MECHANISM
PROJECT DESIGN DOCUMENT FORM (CDM-PDD)
Version 03 - in effect as of: 28 July 2006**

CONTENTS

- A. General description of project activity
- B. Application of a baseline and monitoring methodology
- C. Duration of the project activity / crediting period
- D. Environmental impacts
- E. Stakeholders' comments

Annexes

- Annex 1: Contact information on participants in the project activity
- Annex 2: Information regarding public funding
- Annex 3: Baseline information
- Annex 4: Monitoring information

**SECTION A. General description of project activity****A.1 Title of the project activity:**

Project Name: Guazhou Beidaqiao No.1 Wind Farm Project in Gansu Province, China

Version Number: 4.0

Date: 09/10/2012

Version history:

Version	Date	Description
1.0	25/11/2010	Prepared for and submitted to China's DNA to apply LoA and Version submitted to the DOE for GSP
2.0	25/02/2011	Revised addressing CLs and CARs during validation
3.0	08/06/2011	Final cross check by PP
4.0	09/10/2012	Change on the accuracy of the meter installed at the backup line

A.2. Description of the project activity:

Guazhou Beidaqiao No.1 Wind Farm Project in Gansu Province, China (hereinafter referred to as “the project”) is located in Guazhou County, Jiuquan City, Gansu Province, China. The primary objective of the proposed project is to generate renewable electricity to meet the ever-increasing demand in the Gansu Grid and Northwest China Power Grid (NWPG).

According to the information from Chinese DNA, NWPG includes five provincial grids – Shaanxi Grid, Gansu Grid, Qinghai Grid, Ningxia Grid and Xinjiang Grid. NWPG is dominated by thermal power plants. From 2003 to 2007, the annual percentages of thermal generation in the NWPG are 81.22%, 77.95%, 72.56%, 76.96% and 77.58%, respectively. It is not likely that the energy mix will change significantly in the short term. The proposed project therefore will produce GHG emissions reductions.

The proposed project will install 67 sets of SL1500 wind turbine units and 67 sets of GW1500 wind turbine units at the proposed project site, with a capacity of 1,500 kW per unit. The total installed capacity is 201MW. Dependent on the reliability of the local wind resource, the proposed project is expected to supply 461,464 MWh of electricity annually to the NWPG. In the absence of the proposed project, electricity demand will be met by existing capacity and new installations of the NWPG, which is dominated by thermal power plants. Thus, the baseline scenario is the existing scenario before the implementation of the proposed project; i.e. electricity demand is met by the existing generation mix that makes up the NWPG.

Therefore, the proposed project will achieve GHG emission reductions by displacing electricity generated by thermal power plants in the NWPG with zero emission electricity. The proposed project will achieve estimated annual GHG emission reductions of 428,829 tCO₂e throughout the first crediting period (see section A.4.4).

The proposed project will not only supply renewable electricity, but will also contribute to the sustainable development of the local community and host country by means of:



- Supplying reliable, zero-emissions renewable energy to the NWPG;
- Preserving water resources and improving the local energy infrastructure;
- Increasing local incomes and providing 30 job opportunities;
- Decreasing pollutant emissions from fossil-fuel fired power plants, particularly emissions of SO_x, NO_x and dust.

A.3. Project participants:

Name of Party involved (*) (host) indicates a host Party)	Private and/or public entity(ies) project participants (*) (as applicable)	Kindly indicate if the Party involved wishes to be considered as project participant (Yes/No)
China (host)	Hydrochina Guazhou Wind Power Co., Ltd.	No
United Kingdom	Macquarie Bank Limited	No

A.4. Technical description of the project activity:
A.4.1. Location of the project activity:
A.4.1.1. Host Party(ies):

China

A.4.1.2. Region/State/Province etc.:

Gansu Province

A.4.1.3. City/Town/Community etc:

Jiuquan City, Guazhou County

A.4.1.4. Detail of physical location, including information allowing the unique identification of this project activity (maximum one page):

The proposed project is located in Guazhou County, Jiuquan City, Gansu Province, China, about 18km northwest away from Guazhou County. The geographical coordinates of the proposed project is the Latitude +40.6025 and the Longitude +95.8037.

Figure A-1 and figure A-2 on the next page shows the location of the proposed project.



Figure A.4.1. Map of China

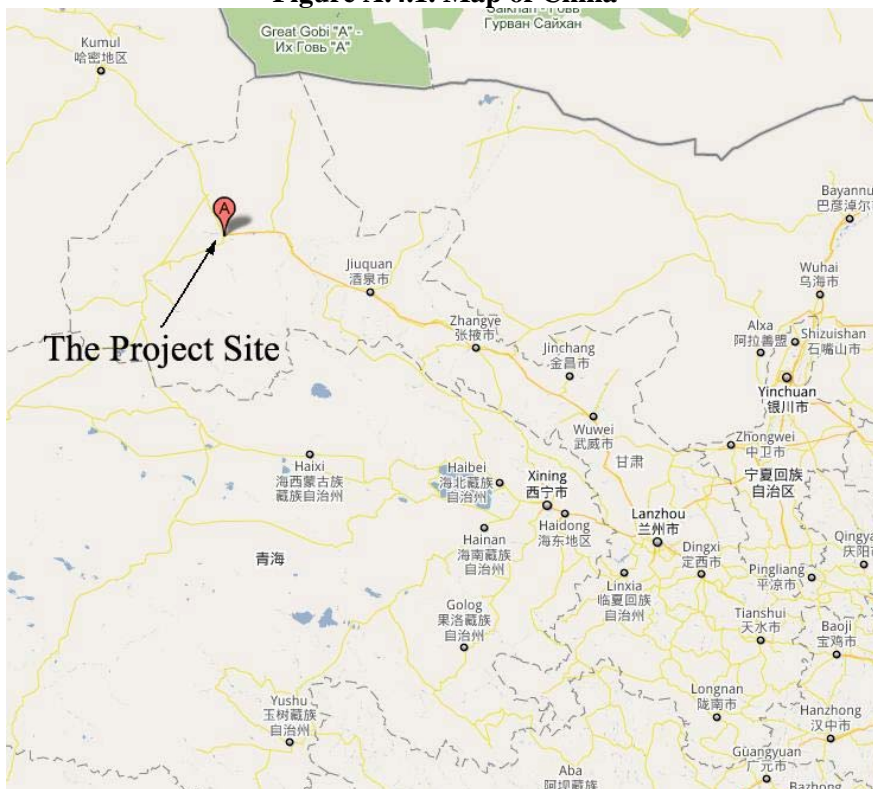

Figure A.4.2. The location of the proposed project

**A.4.2. Category(ies) of project activity:**

The proposed project falls into:

Sectoral Scope 1: Energy Industries (renewable / non-renewable sources)

Project Activity: Grid-connected renewable power generation (A new build wind farm project)

A.4.3. Technology to be employed by the project activity:

According to information published by the Chinese DNA, China is covered by 7 independent grids – Northeast China Power Grid, North China Power Grid, East China Power Grid, Central China Power Grid, Northwest China Power Grid, Southern China Power Grid and Hainan Local Grid. The proposed project will be connected to NWPG, which includes Shaanxi Grid, Gansu Grid, Qinghai Grid, Ningxia Grid and Xinjiang Grid. According to the China Electric Power Yearbook, the electricity generated in the NWPG 2003 to 2007 is listed (by types) in Table 2 of Annex 3. It can be concluded from Table 2 that NWPG is dominated by thermal power plants, and according to Table 14 of Annex 3, the installed capacity of thermal power units increased considerably from 2005 to 2007. Therefore, prior to the construction of the proposed project, or in the absence of the proposed project, electricity demand would be met by the existing capacity connected to the NWPG and through new installations. The NWPG generation mix is dominated by carbon intensive thermal power. Therefore, the baseline scenario is the existing scenario before the implementation of the proposed project; i.e. electricity demand is met by the existing generation mix that makes up the NWPG.

The proposed project will install 134 wind turbine-generators, each with a capacity of 1,500 kW, forming a total capacity of 201 MW. The annual power generation of the project is 461,464 MWh and the annual net power supplied to the grid is 461,464 MWh. The 67 sets of wind turbines model SL1500/77 are manufactured by Sinovel Wind Technology Co., Ltd, and the other 67 sets of wind turbines model GW77/1500 are manufactured by Xinjiang Goldwind Technology Co., Ltd. The technology is introduced from Germany and produced under license.¹ Therefore, the establishment and operation of the proposed project activity will promote technology transfer and utilization in China. The technology is considered good practice in China.

Parameter of Turbines	Unit	Value	Value
Type	/	SL1500/77	GW77/1500
Quantity of Turbine	/	67	67
Rated Power	kW	1500	1500
Cut-in Wind Speed	m/s	3.0	3.0
Cut-out Wind Speed	m/s	20.0	22.0
Rated Wind Speed	m/s	11.0	11.5
Rated Voltage	V	690	690
Expected life	year	22	22

Table A.4.1. Technical Parameters of the Turbines

The proposed project adopts turbine-transformer units to boost voltage from 690V to 35 kV. All the turbine-transformers are linked with the 35 kV suspension lines and are connected to West Beidaqiao Substation, which boosts the voltage from 35kV to 330 kV. The electricity will then be boosted to 750kV through Anxi Substation and be transmitted to NWPG through the 750kV transmission line.

The electricity supplied to the grid can be monitored by M11 and M12 (back-up) installed at the West

¹ <http://www.newenergy.org.cn/html/0085/5290817781.html>

Beidaqiao Substation, and the electricity imported from the grid can be monitored by both M11, M12 (back-up) in the West Beidaqiao Substation and M21 in the project site..The net electricity supplied to the grid is the difference of the electricity supplied to the grid and the electricity imported from the grid.

On average, the project activity is expected to operate 2296 hours per years, which corresponds to output net power of 461,464 MWh to NWPG annually. The plant load factor (PLF) is 26.2%. The simplified flow diagram is shown in the following figure:

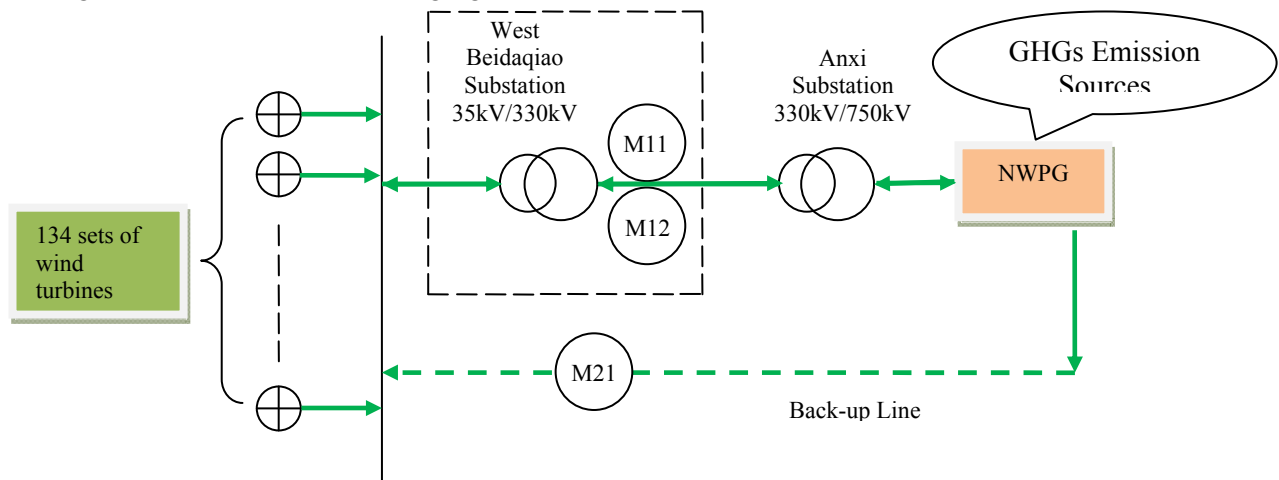

Figure A.4.3. The Energy Flow

According to the methodology ACM0002 (Version 12.1.0), no emission sources and green house gases (GHGs) will be involved in the project activity since it is the installation of a new grid-connected wind power plant.

A.4.4 Estimated amount of emission reductions over the chosen crediting period:

7 years × 3 renewable crediting periods has been chosen for the proposed project. The annual emission reductions due to the proposed project are estimated to be 428,829 tCO₂e and the total reduction over the first crediting period will be 3,001,804 tCO₂e (from 1 December 2011 to 30 November 2018).

Years*	Annual estimation of emission reductions in tonnes of CO ₂ e
2011(1 December - 31 December)	35,735
2012	428,829
2013	428,829
2014	428,829
2015	428,829
2016	428,829
2017	428,829
2018 (1 January – 30 November)	393,093
Total estimated reductions (tonnes of CO₂e)	3,001,804
Total number of first crediting years	7
Annual average over the crediting period of estimated reductions (tonnes of CO₂e)	428,829

**A.4.5. Public funding of the project activity:**

No public funding from Annex I Parties is involved in this project activity.

SECTION B. Application of a baseline and monitoring methodology**B.1. Title and reference of the approved baseline methodology applied to the project activity:**

1. Version 12.1.0 of ACM0002: “Consolidated baseline methodology for grid-connected electricity generation from renewable sources” (EB 58)
2. Version 05.2 of “Tool for the demonstration and assessment of additionality”, in effect as of 26 August 2008.
3. Version 02 of “Tool to calculate the emission factor for an electricity system”, in effect as of 16 October 2009.

For more information regarding the methodology, please refer to the following link:

<http://cdm.unfccc.int/methodologies/PAmethodologies/approved.html>

B.2 Justification of the choice of the methodology and why it is applicable to the project activity:

As a grid-connected wind farm project, the proposed project meets all the applicability criteria of ACM0002 as follows:

- The proposed project is the installation of a new power plant at a site where no renewable power plant was operated prior to the implementation of the project activity (Greenfield plant);
- The proposed project is the installation of a wind power plant;
- The proposed project does not involve switching from fossil fuels to a renewable energy source at the site of the project activity.

Therefore, ACM0002 is applicable to the proposed project.

B.3. Description of how the sources and gases included in the project boundary

According to the information from the Chinese DNA², the spatial extent of the project boundary includes the project site and all power plants connected physically to the NWPG, which the project will be connected to. The grid covers five provinces (Shaanxi, Gansu, Qinghai, Ningxia and Xinjiang).

The project electricity system is defined by the spatial extent of the power plants that can be dispatched without significant transmission constraints. Given the significant transmission occurring between the provincial grids that make up the NWPG, and the difficulty in distinguishing between these individual provincial grids, the NWPG has been selected as the electricity system of the proposed project.

According to the methodology ACM0002, the emissions sources and the category of GHGs is described in Table B-1:

² Notice on 2009 Baseline Emission Factors for Regional Power Grids in China, 3 July 2009 (downloadable from http://qhs.ndrc.gov.cn/qj/zjz/t20090703_289357.htm)

Source		Gas	Included?	Justification / Explanation
Baseline	CO ₂ emissions from electricity generation of the fossil fuel fired power plants connected to the Northwest China Power Grid	CO ₂	Yes	Main emission source
		CH ₄	No	Excluded for simplification. This is deemed a conservative measure.
		N ₂ O	No	Excluded for simplification. This is deemed a conservative measure.
Project Activity	The proposed project	CO ₂	No	Excluded by the methodology for wind farm projects
		CH ₄	No	Excluded by the methodology for wind farm projects
		N ₂ O	No	Excluded by the methodology for wind farm projects

Table B.3.1. The emission source and the category of GHG

The flow diagram of the project boundary is delineated as Figure B.3.1.:

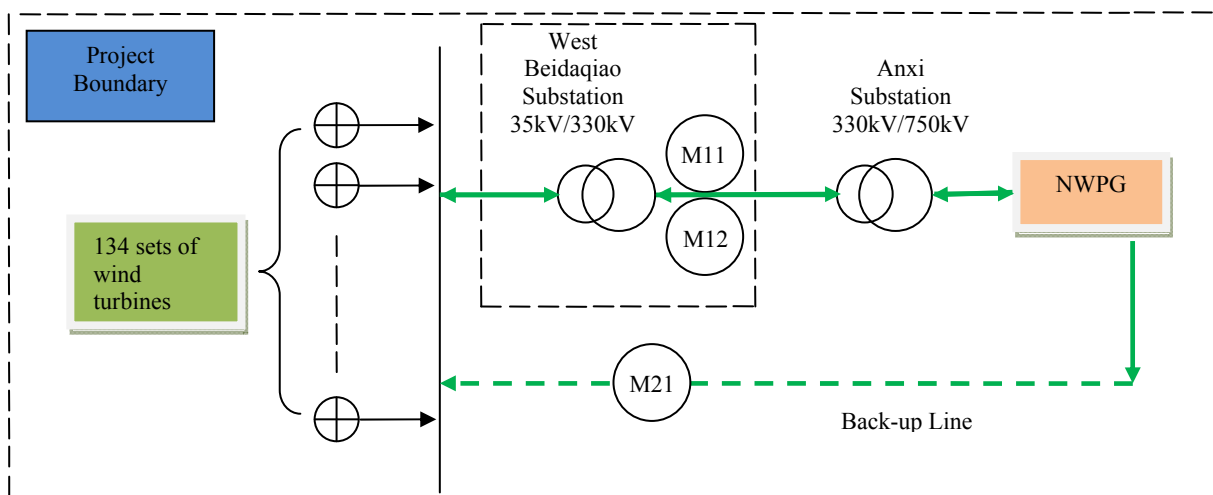

FigureB.3.1. The flow diagram of the project boundary

B.4. Description of how the baseline scenario is identified and description of the identified baseline scenario:

Since the proposed project is a newly built wind farm project, according to methodology ACM0002, the baseline is the following:

Electricity delivered to the grid by the project activity would have otherwise been generated by the operation of grid-connected power plants and by the addition of new generation sources, as reflected in the combined margin (CM) calculations described in the .Tool to calculate the emission factor for an electricity system.



B.5. Description of how the anthropogenic emissions of GHG by sources are reduced below those that would have occurred in the absence of the registered CDM project activity (assessment and demonstration of additionality):

The feasibility study showed that the economics of the proposed project are financially unattractive and the expected return on investment failed to reach the industry benchmark. Therefore the proposed project was considered to be economically infeasible. Therefore, the developer decided to develop the proposed project as a registered CDM project activity, in order to achieve additional revenue from the sale of CERs. The project owner seriously considered CDM before the starting date of the project.

Time	Events
04/2008	EIA completed
06/08/2008	EIA approved
01/2009	FSR completed
21/04/2009	The FSR approval for the proposed project from NDRC
07/06/2009	Board minute of decision to develop the project as a CDM project
24/10/2009	The EPC contract signed (starting date of the project)
25/03/2010	Notification submitted to China DNA (National Development and Reform Committee, NDRC). Notification to EB ³ (As required in EB 48, the notification needs to be sent to not only DNA but also EB, so we sent notification to EB for the adminicle)
25/11/2010	The project owner signed ERPA.

The following steps are used to demonstrate the additionality of the proposed project according to the “Tool for the demonstration and assessment of additionality”:

Step 1. Identification of alternatives to the project activity consistent with current laws and regulations

Sub-step 1a. Define alternatives to the project activity:

Realistic and credible alternatives to the proposed project that provide outputs or services comparable to the proposed project activity include:

- The proposed project activity undertaken without being registered as a CDM project activity;
- Construction of a thermal power plant with equivalent electrical output;
- Construction of a renewable power plant other than wind power with equivalent electrical output, such as hydropower, biomass or solar power;
- Generation to meet demand is supplied by the existing generation mix that makes up the NWPG, and any new future additions.

Besides wind energy, solar PV, geothermal, biomass and hydro power are the grid-connected renewable

³ http://cdm.unfccc.int/Projects/PriorCDM/notifications/index_html



energy technologies that could be applied in China. Due to the high cost of grid connected solar PV⁴, geothermal⁵ and biomass⁶ technologies on a scale that would achieve a similar output to the proposed project, these non-winds renewable power technologies are not considered plausible alternatives to the proposed project. Only hydropower can provide a return on investment comparable to wind power projects in China. Gansu province has a distinct lack of water resources⁷, meaning there is no opportunity for hydropower development at the proposed project's location, or in the surrounding region. Therefore, the alternative c) is considered not feasible.

Outcome of sub-step 1a:

In conclusion, the realistic and credible alternatives to the proposed project, that provides outputs or services comparable to the proposed project, are:

- a) The proposed project activity undertaken without being registered as a CDM project activity;
- b) Construction of a thermal power plant with equivalent electrical output;
- d) Generation to meet demand is supplied by the existing generation mix that makes up the NWPG, and any new future additions.

Sub-step 1b. Consistency with mandatory laws and regulations:

b) Construction of a thermal power plant with equivalent electrical output

In 2007, the average annual operating hours of a Chinese thermal power plant was 5,344 hours⁸. The alternative baseline scenario of constructing a thermal power plant of comparable scale to the proposed project would have an installed capacity of 86.4MW. The proposed project is a grid-connected project, so this alternative scenario must also be grid-connected. According to Chinese power regulations⁹, the construction of thermal power plants smaller than 135 MW is prohibited in areas covered by large grids. Alternative b) conflicts with Chinese power regulations so it therefore not a realistic or credible alternative to the proposed project.

a) The proposed project activity undertaken without being registered as a CDM project activity

This scenario satisfies all mandatory laws and regulations governing power generation in China.

d) Generation to meet demand is supplied by the existing generation mix that makes up the NWPG, and any new future additions.

This scenario is the continuation of current practice and therefore by definition is consistent with all mandatory laws and regulations.

Outcome of sub-step 1b:

Alternative b) is eliminated as it does not comply with Chinese power regulations. Alternatives a) and d)

⁴ <http://www.ck365.cn/hyxx/4615.html>

<http://www.newenergy.org.cn/html/0087/790818772.html>

⁵ <http://www.creinfo.com/view/viewnews.aspx?id=20080131103909265>

⁶ <http://biology.aweb.com.cn/news/2007/7/9/9293227.shtml>;
http://www.86ne.com/Biomass/200712/Biomass_103227.html

⁷ http://amuseum.cdstm.cn/AMuseum/diqiuziyuan/wr0_4.html

⁸ China Electric Power Yearbook 2008 Page 53

⁹ Notice on Strictly Prohibiting the Illegal Installation of coal-fired Generators with the Capacity of 135 MW or below issued by the General Office of the State Council, Guo Ban Fa Ming Dian decree No. 2002-6.



comply with all mandatory laws and regulations in China, so they are taken forward to the investment analysis in Step 2 as the remaining potential alternative scenarios options.

Step 2. Investment Analysis

Sub-step 2a. Determine appropriate analysis method

Following the EB guidance on the assessment of investment analysis, if the alternative to the project activity is the supply of electricity from the grid, this is not considered an investment and a benchmark approach is considered appropriate. As the baseline alternative involves the continuation of current practices, supply of electricity from the grid, a benchmark analysis is used to identify whether the project is economically attractive (Option III). The use of a benchmark analysis is also in line with Chinese practice and is followed in the FSR. Therefore, the benchmark analysis (Option III) is adopted.

Sub-step 2b. Option III. Apply benchmark Analysis

In accordance with *Interim Rules on Economic Assessment of Electrical Engineering Retrofit Projects* issued by former State Power Corporation of China in 2002, the financial benchmark of total investment internal rate of return (post-tax) of Chinese electricity industry is 8% which has been used widely in feasibility studies of new power plants, including wind power projects in China. Only if the total investment IRR of the project (post-tax) is higher than or equivalent to this benchmark, the proposed project is financially feasible. Consequently, the project activity uses 8% as the benchmark in the financial analysis.

Sub-step 2c. Calculation and comparison of financial indicators

1) Parameters used in IRR calculation

Item	Unit	Value	Reference
Installed capacity	MW	201	Feasibility Study Report (FSR)
Annual Electricity delivered to the grid	MWh	461,464	FSR
Investment cost	Million RMB	1,908.03	FSR
Annual O&M Cost (Average)	Million RMB	53	FSR
Expected tariff (Inc. VAT)	RMB/kWh	0.5206 (Within 30,000 hours)	FSR
Value added Tax (VAT)	%	17 ¹⁰	

¹⁰ Value Added Tax: The rate of VAT is 17%, and the rate of VAT drawback is 50%, applicable to the wind power industry in accordance with *National VAT Law (State Council [2008]538)* issued by State Administration of Taxation and *VAT policy on Comprehensive Utilization of Resource* (Source: <http://www.js-ntax.gov.cn/Page1/StatuteDetail.aspx?StatuteID=8862>) and *Other Products (Cai Shui[2008]156)* released by Ministry of Finance and State Administration of Taxation (Source: <http://www.js-ntax.gov.cn/Page1/StatuteDetail.aspx?StatuteID=8931>). Also applicable is the “*Notice about implementation of VAT reform in the whole country*” (Cai Shui [2008]170) (Source: <http://202.108.90.130/n8136506/n8136563/n8193451/n8193466/n8193602/8884823.html>), which allows the VAT incurred by the purchase of equipments can be recouped over the operation period against the VAT for electricity sales until the VAT from the equipment is fully recovered. Both VAT reduction policies are taken into account in the PDD. So, this is conservative.



City Build Tax	%	7	FSR
Education Tax	%	3	FSR
Revenue tax	%	25	FSR
Residual rate	%	3	FSR

Table B.5.1. Parameters for calculation of IRR

2) Comparison of the project IRR and the financial benchmark

Table B-3 shows the project IRR for the proposed project with and without the additional revenue from sales of CERs. Without carbon finance the project IRR is 5.81% which is lower than the financial benchmark. Adding in the additional revenues from the CDM, the project IRR is increased to 9.35%, higher than the financial benchmark. Therefore, it is concluded that in the absence of any addition revenue from the sale of CERs, the proposed project is not a financially attractive investment opportunity. However, with the additional income from the CDM, the project overcomes the financial benchmark and can be seen as financially viable.

	Without CDM	Benchmark	With CDM
IRR	5.81%	8%	9.35%

Table B.5.2. Comparison of IRR with and without the income from CERs sale**Sub-step 2d. Sensitivity analysis**

For the proposed project, the following 4 parameters were selected as key input values to the IRR calculation that have been subjected to a sensitivity analysis to illustrate the robustness of the analysis:

- 1) Static Investment
- 2) Annual O&M cost
- 3) On-grid tariff
- 4) Annual generation

The variation applied to these four factors which impacts the project IRR (without carbon finance) to the extent that it reaches the 8% investment benchmark, is shown in Table B-4 and Figure B-2 below.

Parameter	Range	-10.0%	0.0%	10.0%
Static Investment		7.04%	5.81%	4.73%
Annual O&M cost		6.19%	5.81%	5.42%
On-grid tariff		4.16%	5.81%	7.31%
Annual generation		4.16%	5.81%	7.31%

Table B.5.3. Sensitivity analysis of the proposed project



Figure B.5.1. Sensibility analysis of the proposed project

The sensitivity analysis shows that without CER revenue the IRR for the project will not reach the benchmark under +/-10% variation, which shows that the sensitivity analysis regarding the financial attractiveness is robust to +/-10% variations in the critical assumptions.

Range of variables IRR =8%		
	Range	Value (million RMB)
Static Investment	-16.8%	1587.48
Annual O&M cost	-62.5%	21.50
On-grid tariff	14.9%	0.60
Annual generation	14.9%	530222.14

Table B.5.4. Range of variables of IRR

The project IRR will reach the benchmark (8%) at the following assumptions, but it very unlikely happen due to:

Only when the static total investment has a drop of 16.8%, the project IRR can reach the benchmark rate. However, as the prices, including those of the requirement equipment and commodities, have been increasing in recent years¹², a significant reduction in the level of investment is unlikely, in particular a reduction greater than 16.8%. Furthermore, by reviewing the purchase agreements of wind turbines and wind-power towers and the construction contract, it can be concluded that the already signed contract values are higher than those estimated in the approved FSR. Therefore, it is impossible for the proposed project to reduce the static total investment to make the project IRR higher than the benchmark of 8%;

Only when the annual O&M cost has a drop of 62.50%, the project IRR can reach the benchmark rate. The annual O&M costs mainly include maintenance costs, wage and welfare, material cost and other costs. Transparently, it is impossible for the operation & maintenance cost to 62.5%. Therefore, the



annual O&M cost will not be changed to make the project IRR equal to the benchmark;

Only when the grid-in tariff increases by 14.9%, the project IRR can reach the benchmark rate. The electricity tariff 0.5206RMB/kWh (Inc. VAT) used in the PDD is sourced from the approved FSR. The FSR of the proposed project was approved by the NDRC. According to Fagainengyuan [2009] No. 1005, the tariff of the wind farm project officially approved was two-phase tariff. The tariff before 30,000 hours will be fixed (i.e. 0.5206 RMB/kWh (Inc. VAT)), the tariff after 30,000 hours will be set at the average tariff of the local grid (0.24901 RMB/kWh (Inc. VAT) in 2008) which is far lower than 0.5206 RMB/kWh (Inc. VAT, after 30,000 hours) used in IRR calculation. So, it is conservative and reasonable to use 0.5206RMB /kWh (Inc. VAT) as the tariff for whole life. Moreover, even if the highest tariff issued for similar projects in Gansu Province 0.585 RMB/kWh (Inc. VAT) was used in the IRR calculation for whole life, the project IRR would be still lower than the benchmark of 8%. To sum up, there is no chance for the tariff (0.5206 RMB/kWh (Inc. VAT)) of the project to be changed to make the project IRR higher than or equal to the benchmark;

Only when the annual electricity output increase by 14.90%, the project IRR can reach the benchmark rate. In the Approved FSR the expected annual electricity output of the proposed project were calculated based on 30 years of historical wind speeds measured by Local Meteorological Station, the institute calculated the operational hours according to the *Methodology of Wind Energy Resource Assessment for Wind Farm* (GB/T18710-2002). The calculations for the project were carried out using professional WASP software designed for wind energy, which is used by wind developers and turbines manufacturers worldwide. As the calculation were based on historical data, assuming a sustained 14.90% of increase in annual electricity output is not reasonable. Therefore, it is very unlikely for the project to become commercially attractive through an adjustment of the annual electricity output.

In conclusion, the proposed project is not financially feasible without the revenue of CERs and thus is additional.

Step 3. Barrier analysis

The investment analysis has fully demonstrated and explained the additionality of the project, so step 3 is skipped.

Step 4. Common practice analysis

Sub-step 4a. Analyze other activities similar to the proposed project activity

An analysis has been done to identify similar activities to the proposed project. Given the characteristics of the proposed project, other similar activities are considered to be those located in the same region, using the same renewable energy technology (i.e. wind turbines) and be of a similar scale with an installed capacity between 100 MW and 300 MW. Similar activities must also be exposed to a similar wind resource, be governed by a similar policy framework, have access to the same human resources, and incur similar material and financing costs. According to these criteria, an analysis was done on wind power projects in Gansu Province. This analysis identified that there is only one similar project which is not applying CDM- Gansu Anxi (Jiuquan phase 1) Wind Farm Project, 100.5 MW .

Sub-step 4b. Discuss any similar options that are occurring:



The Gansu Anxi (Jiuquan phase 1) Wind Farm Project, 100.5 MW has been registered as Gold Standard VER project¹¹. The development of large scale wind farms in Gansu Province face considerable financial barriers, and without higher supporting tariffs or favorable financial support, projects will struggle to overcome these barriers. The Gansu Anxi (Jiuquan phase 1) Wind Farm Project, 100.5 MW faces the same challenges as the proposed project, so it is also seeking financial assistance from the Gold Standard VER.

Outcome of step 4:

From the above analysis and discussion it is concluded that the proposed project is not common practice. Therefore, the proposed project activity is additional.

B.6. Emission reductions:

B.6.1. Explanation of methodological choices:

ACM0002 and 2009 *Baseline Emission Factors for Regional Power Grids in China*¹² are applied as the following steps, and the data are from *China Electric Power Yearbook* and *China Energy Statistical Yearbook*.

- I. Calculating the Baseline Emission (BE_y);
- II. Calculating the Project Emission (PE_y);
- III. Calculating the Leakage Emission (LE_y);
- IV. Calculating the Emission Reduction (ER_y)

I. Calculating the Baseline Emission

The baseline emission factor is calculated as a Combined Margin, which consists of the weighted average of Operating Margin emission factor and Build Margin emission factor by utilizing the latest data vintage for NWPG, then the baseline emission (BE_y) is calculated as below:

$$BE_y = EG_{PJ,y} \cdot EF_{grid,CM,y} \quad (1)$$

Where,

BE_y = Baseline emission in year y (tCO₂e/yr)

$EG_{PJ,y}$ = Quantity of net electricity generation that is produced and fed into the grid as a result of the implementation of the CDM project activity in year y (MWh/yr)

$EF_{grid,CM,y}$ = Combined margin CO₂ emission factor for grid connected power generation in year y (tCO₂e/MWh)

The project activity is the installation of a new grid-connected renewable power plant at the site where no renewable power plant was operated prior to the implementation of the project activity, then:

$$EG_{PJ,y} = EG_{facility,y} \quad (2)$$

Where,

$EG_{facility,y}$ = Quantity of net electricity generation supplied by the project plant to the grid in year y (MWh/yr)

¹¹ <https://gs1.apx.com/myModule/rpt/myrpt.asp?r=111>

¹² http://qhs.ndrc.gov.cn/qjzjz/t20090703_289357.htm



According to *Tool to calculate the emission factor for an electricity system* (Version 02), seven steps are applied to calculate the baseline emission factor:

Step 1 – Identify the relevant electric power system.

Step 2- Choose whether to include off-grid power plants in the project electricity system (optional).

Step 3–Select an operating margin (OM) method.

Step 4 –Calculate the operating margin emission factor according to the selected method ($EF_{grid,OM,y}$).

Step 5 –Identify the group of power units to be included in the build margin (BM).

Step 6 –Calculate the build margin emission factor ($EF_{grid,BM,y}$).

Step 7 –Calculate the combined margin (CM) emission factor ($EF_{grid,CM,y}$).

Step 1. Identify the relevant electric power system

The power generated by the project will be supplied to the NWPG. According to “2009 Baseline Emission Factors for Regional Power Grids in China” which is renewed by the Office of the National Coordination Committee on Climate Change of the National Development and Reform Commission (NDRC) of China (the DNA of China) in July 3, 2009, the NWPG is a regional grid, which consists of five sub-grids: the Shaanxi Grid, the Gansu Grid, the Qinghai Grid, the Ningxia Grid and the Xinjiang Grid.

There isn't any net electricity import from other grids to NWPG.

Step 2: Choose whether to include off-grid power plants in the project electricity system (optional).

Project participants may choose between the following two options to calculate the operating margin and build margin emission factor:

Option I: Only grid power plants are included in the calculation.

Option II: Both grid power plants and off-grid power plants are included in the calculation

Following the calculations of the China's DNA, and the statistical data available, Option I is chosen.

Step 3. Select an Operating Margin (OM) method

The calculation of $EF_{grid,OM,y}$ is based on one of the four following methods:

- (a) Simple OM, or
- (b) Simple Adjusted OM, or
- (c) Dispatch Data Analysis OM, or
- (d) Average OM.

Because the detailed dispatch data of NWPG is unavailable, method (c) and method (b) are not applicable.

According to the total electricity generated in 2003-2007 by NWPG, the low-cost / must-run resources constitute less than 50% of total amount of grid generating output (see Annex 3 for details). Therefore, the Average OM method is not applicable.

The Simple OM method can be used to calculate the OM emission factor.

For the simple OM method, the emission factor can be calculated using either of the two following data



vintage:

- Ex ante option: A 3-year generation-weighted average, based on the most recent data available at the time of submission of the CDM-PDD to the DOE for validation, without requirement to monitor and recalculate the emissions factor during the crediting period, or
- Ex post option: The year in which the project activity displace grid electricity, requiring the emission factor to be updated annually during monitoring.

The project participants chose to use the ex-ante vintages and fix the emission factor for the duration of the crediting period.

Step 4. Calculate the Operating Margin emission factor according to the selected method

According to the Tool, the simple OM emission factor in y year ($EF_{grid,OMsimple,y}$) is calculated as generation-weighted average CO₂ emissions per unit net electricity generation (tCO₂e/MWh) of all generating power plants serving the system, not including low-cost / must-run power plants. It may be calculated:

- Option A: Based on data on fuel consumption and net electricity generation of each power plant / unit, or
- Option B: Based on data on net electricity generation, the average efficiency of each power unit and the fuel type(s) used in each power unit, or
- Option C: Based on data on the total net electricity generation of all power plants serving the system and the fuel types and the total fuel consumption of the project electricity system.

Option A should be preferred and must be used if fuel consumption data is available for each power plant / unit. In other cases, option B or option C can be used. For the purpose of calculating the simple OM, option C should only be used if the necessary data for option A and option B is not available and can only be used if only nuclear and renewable power generation are considered as low-cost / must-run power sources and if the quantity of electricity supplied to the grid by these sources is known.

In China, there is no available data for the detailed fuel consumption, net electricity generation and average efficiency of each power plant / unit, so option C is selected for calculating the OM emission factor. The formula of $EF_{grid,OM,simple,y}$ is:

$$EF_{grid,OMsimple,y} = \frac{\sum_i FC_{i,y} \cdot NCV_{i,y} \cdot EF_{CO_2,i,y}}{EG_y} \quad (3)$$

Where:

$EF_{grid,OM,simple,y}$ = Simple operating margin CO₂ emission factor in year y (tCO₂e/MWh)

$FC_{j,y}$ = Amount of fossil fuel type i consumed in NWPG in year y (mass or volume unit)

$NCV_{i,y}$ = Net calorific value (energy content) of fossil fuel type i in year y (GJ/mass or volume unit)

$EF_{CO_2,i,y}$ = CO₂ emission factor of fossil fuel type in year y (tCO₂e/GJ)

EG_y = Net electricity generated and delivered to NCPG by all power sources serving the system, not including low-cost / must-run power plants / units, in year y (MWh)

i = All fossil fuel types combusted in power sources in NWPG in year y

y = The three most recent years for which data is available at the time of submission of the CDM-PDD to the DOE for validation (ex ante option)

**Step 5. Identify the group of power units to be included in the Build Margin**

According to the Tool, the sample group of power units m used to calculate the build margin consists of either:

- (a) The set of five power units that have been built most recently, or
- (b) The set of power capacity additions in the electricity system that comprise 20% of the system generation (in MWh) and that have been built most recently.

The Tool emphasises that project participants should use the set of power units that comprises the larger annual generation, so we choose (b) to calculate.

In terms of vintage of data, project participants can choose between one of the following two options:

Option 1: For the first crediting period, calculate the build margin emission factor *ex-ante* based on the most recent information available on units already built for sample group m at the time of CDM-PDD submission to the DOE for validation. For the second crediting period, the build margin emission factor should be updated based on the most recent information available on units already built at the time of submission of the request for renewal of the crediting period to the DOE. For the third crediting period, the build margin emission factor calculated for the second crediting period should be used. This option does not require monitoring the emission factor during the crediting period.

Option 2: For the first crediting period, the build margin emission factor shall be updated annually, *ex-post*, including those units built up to the year of registration of the project activity or, if information up to the year of registration is not yet available, including those units built up to the latest year for which information is available. For the second crediting period, the build margin emission factor shall be calculated *ex-ante*, as described in option 1 above. For the third crediting period, the build margin emission factor calculated for the second crediting period should be used.

The proposed project applies option 1 to calculate the build margin emission factor *ex-ante*. But recently in China, the power plants see the build margin as the vital business data, so it is very difficult to find the available data about the power units consists of either the set of five power units that have been built most recently, or the set of power capacity additions in the electricity system that comprise 20% of the system generation (in MWh) and that have been built most recently. To resolve this problem, the Executive Board (EB) has approved the project participants to use the methodological deviation¹³ as follows:

- (1) Use of capacity additions during the last 1-3 years for estimating the build margin emission factor for grid electricity.
- (2) Use of weights estimated using installed capacity in place of annual electricity generation. And it is suggested that the project participants use the efficiency level of the best technology commercially available in the provincial, regional or national grid of China, as a conservative proxy.

Step 6. Calculate the Build Margin emission factor

According to the Tool, the Build Margin emission factor ($EF_{grid,BM,y}$) is calculated as the generation-weighted average emission factor of a sample of power plants m , the formula is as follows:

¹³EB guidance for “Request for guidance: Application of AM0005 and AMS-ID in China, 2005.10.7” : Request for clarification on use of approved methodology AM0005 for several projects in China. <http://cdm.unfccc.int/Projects/Deviations>



$$EF_{grid, BM, y} = \frac{\sum_m EG_{m,y} \times EF_{EL,m,y}}{\sum_m EG_{m,y}} \quad (4)$$

Where:

$EF_{grid, BM, y}$ = Build Margin CO₂ emission factor in year y (tCO₂e/MWh)

$EG_{m,y}$ = Net Quantity of electricity generated and delivered to NWPG by power unit m in year y (MWh)

$EF_{EL,m,y}$ = CO₂ emission factor of power unit m in year y (tCO₂e/MWh)

m = Power units included in the build margin

y = Most recent historical year for which power generation data is available

The CO₂ emission factor of power unit m ($EF_{EL,m,y}$) should be determined as per the guidance in Step 3 for the simple OM, using option B1 (Deviation relevant details in Step 4 can be the reference), so we can conclude the formula of calculating $EF_{grid, BM, y}$ from the formula in option B1 and formula (2) as follow:

Due to the difficulty of separating the coal-fired, gas-fired or oil-fired installed capacity from the total thermal installed capacity, according to the permitted deviation by CDM EB, the Build Margin emission factor ($EF_{grid, BM, y}$) will be calculated as: 1) Based on the most recent year's energy balance of NECG, calculating the percentages of CO₂ emissions from the coal-fired, oil-fired and gas-fired power plants in total thermal CO₂ emissions; 2) based on the most advanced commercialized technologies which applied by the coal-fired, oil-fired and gas-fired power plants, calculating the thermal emission factor of NECG; 3) calculating the Build Margin emission factor ($EF_{grid, BM, y}$) through thermal emission factor times the weighted-average of thermal installed capacity which is more close to 20% in the new capacity additions. The detailed calculation as follows:

Sub-step 1:

Calculate the proportion of CO₂ emissions related to consumption of coal, oil and gas fuel used for power generation as compared to total CO₂ emissions from the total fossil fuel electricity generation (sum of CO₂ emissions from coal, oil and gas).

$$\lambda_{Coal,y} = \frac{\sum_{i \in COAL, j} FC_{i,j,y} \times NCV_{i,y} \times EF_{CO_2,i,j,y}}{\sum_{i,j} FC_{i,j,y} \times NCV_{i,y} \times EF_{CO_2,i,j,y}} \quad (5)$$

$$\lambda_{Oil,y} = \frac{\sum_{i \in OIL, j} FC_{i,j,y} \times NCV_{i,y} \times EF_{CO_2,i,j,y}}{\sum_{i,j} FC_{i,j,y} \times NCV_{i,y} \times EF_{CO_2,i,j,y}} \quad (6)$$

$$\lambda_{Gas,y} = \frac{\sum_{i \in GAS, j} FC_{i,j,y} \times NCV_{i,y} \times EF_{CO_2,i,j,y}}{\sum_{i,j} FC_{i,j,y} \times NCV_{i,y} \times EF_{CO_2,i,j,y}} \quad (7)$$

Where:

$FC_{i,j,y}$ = the amount of fuel i (in a mass or volume unit) consumed by relevant power sources j in year(s) y ;

$NCV_{i,y}$ = the net calorific value (energy content) of fossil fuel type i in year y (GJ/mass or volume unit) ;

$EF_{i,j,y}$ = the CO₂ emission factor of fuel i in year(s) y (tCO₂e/GJ) ;

λ_{Coal} = the percentage of CO₂ emissions from the coal-fired power plants in total thermal CO₂



emissions;

λ_{Oil} = the percentage of CO₂ emissions from the oil-fired power plants in total thermal CO₂ emissions;

λ_{Gas} = the percentage of CO₂ emissions from the gas-fired power plants in total thermal CO₂ emissions;

Sub-step 2:

Calculate the operating margin emission factor of fuel-based generation:

$$EF_{Thermal} = \lambda_{Coal} \times EF_{Coal,Adv} + \lambda_{Oil} \times EF_{Oil,Adv} + \lambda_{Gas} \times EF_{Gas,Adv} \quad (8)$$

Where:

$EF_{Thermal}$ = the thermal emission factor;

$EF_{Coal,Adv}$, $EF_{Oil,Adv}$ and $EF_{Gas,Adv}$ are corresponding to the emission factors of coal, oil and gas fired power plants which are applied by the most advanced commercialized technologies.

The weighted average of coal consumption per kWh supplied of 30 new built 600 MW sub critical units in 2007 is adopted to determine the emission factor of the best advanced coal fired generation technology, which is 322.5 gce/kWh. In other words, the efficiency of best advanced coal fired generation technology is 38.10%. The maximum electricity supplied efficiency of oil and gas fired generation plants are regarded as approximate estimation of commercially optimal efficiency technology. Similarly, the fuel consumption per kWh supplied of best advanced oil and gas fired generation technology is determined to be 246 gce/kWh, which means a generation efficiency of 49.99%.

The installation capacity, generation data, and average self consumption rate data are from the China Electric Power Yearbooks (2004-2008) and China Energy Statistical Yearbook (2007).

The data of fuel consumption per electricity generated and low calorific values of fuels are from the China Energy Statistical Yearbooks (2004-2008).

The $EF_{CO_2,i}$ data by fuels are from Table 1-2 in P.1.6 and Table 1-4 in P.1.8 in first chapter of “2006 IPCC Guidelines for National Greenhouse Gas Inventories”

Sub-step 3:

Calculate the Build Margin emission factor

$$EF_{grid,BM,y} = \frac{CAP_{Thermal}}{CAP_{Total}} \times EF_{Thermal} \quad (9)$$

Where:

$EF_{grid,BM,y}$ = the Build Margin emission factor with advanced commercialized technologies for year y ;

CAP_{Total} = the new capacity additions;

$CAP_{Thermal}$ = the new thermal capacity additions.

As mentioned above, the build margin emission factor of the baseline is calculated *ex-ante* and will not be renewed in the first crediting period.

Step 7. Calculate the Combined Margin emission factor

The combined margin emissions factor is calculated as follows:

$$EF_{grid,CM,y} = \omega_{OM} \cdot EF_{grid,OM,y} + \omega_{BM} \cdot EF_{grid,BM,y} \quad (10)$$

Where:

$EF_{grid,BM,y}$ = Build Margin CO₂ emission factor in year y (tCO₂e/MWh)

$EF_{grid,OM,y}$ = Operating margin CO₂ emission factor in year y (tCO₂e/MWh)



ω_{OM} = Weighting of operating margin emissions factor (%)

ω_{BM} = Weighting of build margin emissions factor (%)

According to Tool, the default weights of wind farm projects are as follows:

$$\omega_{OM}=0.75, \quad \omega_{BM} = 0.25$$

Therefore, baseline emission can be calculated as below:

$$BE_y = EF_{grid,CM,y} \times EG_{facility,y} \quad (11)$$

$$EG_{facility,y} = EG_{Export,y} - EG_{Import,y}$$

Where,

$EG_{Export,y}$ = Electricity supplied to the grid by the proposed project in year y;

$EG_{Import,y}$ = Electricity achieved by the proposed project from the grid in year y.

II. Project Emission

According to ACM0002, there are no expected project emissions for a wind farm project.

Therefore, $PE_y = 0$

III. Leakage Emission

According to ACM0002, no leakage emissions are considered.

IV. Emission Reduction

Emission reductions will be estimated based on the baseline emission, the project emission and the leakage emission. The emission reduction ER_y , due to the proposed project activity during a given year y is calculated as follows:

$$ER_y = BE_y - PE_y \quad (12)$$

B.6.2. Data and parameters that are available at validation:

Data / Parameter:	EG_y
Data unit:	MWh
Description:	The power supplied to the grid from Shaanxi, Gansu, Qinghai, Ningxia and Xinjiang in 2003-2007
Source of data used:	Electric Power Yearbooks (2004-2008) and China Energy Statistical Yearbook (2007)
Value applied:	Details in Annex 3
Justification of the choice of data or description of measurement methods and procedures actually applied :	Data that is collected from the Chinese official statistics.
Any comment:	Official data, used for OM and BM calculation

Data / Parameter:	$FC_{i,y}$
Data unit:	$10^4t, 10^7m^3$



Description:	Amount of fossil fuel type i (in a mass or volume unit) consumed in NWPG in 2005-2007
Source of data used:	<i>China Energy Statistical Yearbook 2006-2008</i>
Value applied:	See Annex 3 for details
Justification of the choice of data or description of measurement methods and procedures actually applied :	Data that is collected from the Chinese official statistics.
Any comment:	Official data, used for OM and BM calculation

Data / Parameter:	$EF_{CO_2,i,y}$
Data unit:	tCO ₂ e/GJ
Description:	CO ₂ emission factor of fossil fuel type i in 2005-2007
Source of data used:	<i>2006 IPCC Guidelines for National Greenhouse Gas Inventories</i>
Value applied:	See Annex 3 for details
Justification of the choice of data or description of measurement methods and procedures actually applied :	Data that is collected from the IPCC because the local data is not available.
Any comment:	Official data, used for OM and BM calculation

Data / Parameter:	$NCV_{i,y}$
Data unit:	GJ/t, GJ/m ³
Description:	Net calorific value (energy content) of fossil fuel type i in 2005-2007
Source of data used:	<i>China Energy Statistical Yearbook 2008</i>
Value applied:	See Annex 3 for details
Justification of the choice of data or description of measurement methods and procedures actually applied :	Data that is collected from the Chinese official statistics.
Any comment:	Official data, used for OM and BM calculation

Data / Parameter:	$CAP_{i,y}$
Data unit:	MW
Description:	Installed capacities of Shaanxi, Gansu, Qinghai, Ningxia and Xinjiang in 2005-2007
Source of data used:	<i>China Electric Power Yearbook 2006-2008</i>
Value applied:	See Annex 3 for details
Justification of the choice of data or description of measurement methods and procedures actually applied :	Data that is collected from the official statistics.



applied :	
Any comment:	Official data, used for BM calculation

Data / Parameter:	<i>Auxiliary Power Ratio</i>
Data unit:	%
Description:	The auxiliary power ratio of source <i>j</i> in Shaanxi, Gansu, Qinghai, Ningxia and Xinjiang in 2005-2007
Source of data used:	China Electric Power Yearbook 2006-2008
Value applied:	See Annex 3 for details
Justification of the choice of data or description of measurement methods and procedures actually applied :	Data that is collected from the official statistics.
Any comment:	Official data, used for OM and BM calculation

Data / Parameter:	$EF_{Coal, Adv}$
Data unit:	%
Description:	The fuel consumption rate of coal-fired power plants which are applied by the most advanced commercialized technologies.
Source of data used:	From Chinese DNA
Value applied:	38.10%
Justification of the choice of data or description of measurement methods and procedures actually applied :	Data that is collected from the official statistics.
Any comment:	Official data, used for BM calculation

Data / Parameter:	$EF_{Oil, Adv}$
Data unit:	%
Description:	The fuel consumption rate of Oil-fired power plants which are applied by the most advanced commercialized technologies.
Source of data used:	From Chinese DNA
Value applied:	49.99%
Justification of the choice of data or description of measurement methods and procedures actually applied :	Data that is collected from the official statistics.
Any comment:	Official data, used for BM calculation

Data / Parameter:	$EF_{Gas, Adv}$
Data unit:	%
Description:	The fuel consumption rate of Gas-fired power plants which are applied by the



	most advanced commercialized technologies.
Source of data used:	From Chinese DNA
Value applied:	49.99%
Justification of the choice of data or description of measurement methods and procedures actually applied :	Data that is collected from the official statistics.
Any comment:	Official data, used for BM calculation

B.6.3 Ex-ante calculation of emission reductions:

I. Baseline Emission

Therefore, the Operating Margin emission factor ($EF_{grid,OM,simple,y}$) is the weighted emission factors of 2005–2007:

$$EF_{grid,OM,simple,y} = 1.0246 \text{ tCO}_2\text{e/MWh}$$

The Build Margin emission factor can be calculated by formula (4)-(9):

$$EF_{grid,BM,y} = 0.6433 \text{ tCO}_2\text{e/MWh}$$

The baseline emission factor $EF_{grid,CM,y}$ is calculated as formula (10). Thus,

$$EF_{grid,CM,y} = 0.92928 \text{ tCO}_2\text{e/MWh}$$

The baseline emission BE_y is calculated as formula (11):

$$BE_y = 0.92928 \times 461,464 = 428,829 \text{ tCO}_2\text{e/year}$$

II. Project Emission

$$PE_y = 0.$$

III. Emission Reduction

The Emission Reductions (ER_y) for the proposed project activity could be calculated as the formula (12):

$$ER_y = 428,829 - 0 = 428,829 \text{ tCO}_2\text{e/year}$$

**B.6.4 Summary of the ex-ante estimation of emission reductions:**

Year	Estimation of project activity emissions (tonnes of CO ₂ e)	Estimation of baseline emissions (tonnes of CO ₂ e)	Estimation of leakage (tonnes of CO ₂ e)	Estimation of overall emission reductions (tonnes of CO ₂ e)
2011(1 December - 31 December)	0	35,735	0	35,735
2012	0	428,829	0	428,829
2013	0	428,829	0	428,829
2014	0	428,829	0	428,829
2015	0	428,829	0	428,829
2016	0	428,829	0	428,829
2017	0	428,829	0	428,829
2018 (1 January – 30 November)	0	393,093	0	393,093
Total (tonnes of CO₂e)	0	3,001,804	0	3,001,804

B.7 Application of the monitoring methodology and description of the monitoring plan:**B.7.1 Data and parameters monitored:**

Data / Parameter:	$EG_{Facility,y}$
Data unit:	MWh
Description:	Net electricity supplied to NWPG by the proposed project in year y
Source of data to be used:	Calculated from $EG_{export,y}$ and $EG_{import,y}$
Value of data applied for the purpose of calculating expected emission reductions in section B.5	461,464 MWh
Description of measurement methods and procedures to be applied:	$EG_{facility,y} = EG_{export,y} - EG_{import,y}$ $EG_{import,y} = EG_{import1,y} + EG_{import2,y} \times (1+0.5\%)$
QA/QC procedures to be applied:	The measurement will be in compliance with the relevant industry requirements. The calibration will be carried out according to relevant national standards and regulations by authorized organisation. Data measured will be cross checked by records or sales receipts.
Any comment:	/

Data / Parameter:	$EG_{export,y}$
Data unit:	MWh
Description:	Electricity supplied by the project activity to the grid in year y
Source of data to be used:	Measured by electricity meter
Value of data applied	461,464 MWh



for the purpose of calculating expected emission reductions in section B.5	
Description of measurement methods and procedures to be applied:	Continuous measurement and at least monthly recording. Data will be archived electronically and with paper backup, and be kept at least for 2 years after the end of the last crediting period.
QA/QC procedures to be applied:	The calibration will be carried out according to relevant national standards and regulations by authorized organisation. Data measured will be cross checked by records or sales receipts.
Any comment:	/

Data / Parameter:	$EG_{import1,y}$
Data unit:	MWh
Description:	Electricity imported from the grid through the main meter to the project activity in year y
Source of data to be used:	Measured by electricity meter
Value of data applied for the purpose of calculating expected emission reductions in section B.5	0
Description of measurement methods and procedures to be applied:	Continuous measurement and at least monthly recording. Data will be archived electronically and with paper backup, and be kept at least for 2 years after the end of the last crediting period.
QA/QC procedures to be applied:	The calibration will be carried out according to relevant national standards and regulations by authorized organisation. Data measured will be cross checked by records or sales receipts.
Any comment:	/

Data / Parameter:	$EG_{import2,y}$
Data unit:	MWh
Description:	Electricity imported from the grid through the backup line to the project activity in year y
Source of data to be used:	Measured by electricity meter installed in the backup line
Value of data applied for the purpose of calculating expected emission reductions in section B.5	0
Description of measurement methods and procedures to be applied:	Continuous measurement and at least monthly recording. Data will be archived electronically and with paper backup, and be kept at least for 2 years after the end of the last crediting period.
QA/QC procedures to	The calibration will be carried out according to relevant national standards and



be applied:	regulations by authorized organisation. Data measured will be cross checked by records or sales receipts.
Any comment:	In the monitoring Plan of the registered PDD, the accuracy of electricity meter M21 installed to monitor the electricity imported from the grid via the backup line 0.5 (the error will not exceed 0.5%). The accuracy of the main meter M21 actually installed is 1.0 (the error will not exceed 1.0%). For conservative, the differences between the electricity meters accuracy will be applied in determination of the electricity imported via the backup line

B.7.2 Description of the monitoring plan:

The monitoring plan is to serve as a guideline for the project owner to monitor the emission reductions of the proposed project. A more detailed Monitoring and Management Manual for the proposed project will be completed before the project becomes operational. The contents of the Monitoring and Management Manual are highlighted as follows:

1. Monitoring subject

The main data to be monitored is $EG_{Export,y}$ and $EG_{Import,y}$, $EG_{facility,y}$ used to calculate the emission reduction is calculated as $EG_{Export,y} - EG_{Import,y}$. To assume the annual emission reduction in the PDD, 461,464MWh is used as $EG_{facility,y}$ in accordance with the FSR. The calibration procedure, QA/QC and date management of the proposed project will also be monitored.

2. Monitoring management structure

In order to obtain effective monitored data, the project owner will establish a CDM Monitoring Office and designate qualified staffs responsible for all relevant matters, including monitoring, data collection and archiving, QC/QA, and verification. The structure of the CDM Monitoring Office is outlined in Figure B.7.1.

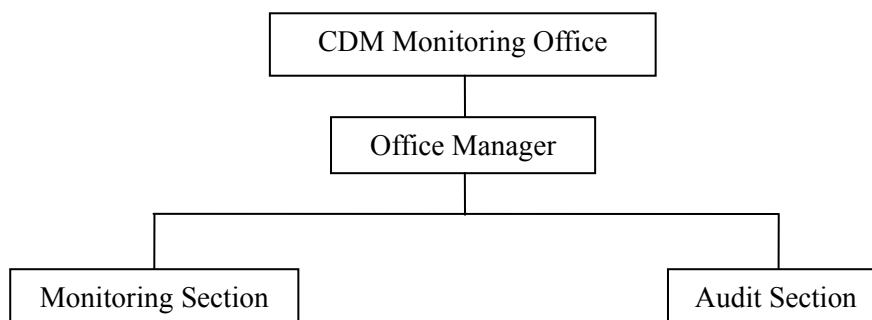

Figure B.7.1. Organization Chart of the CDM Project Management Office

The responsibilities of the sections are briefly described as following:

- Office Manager: Manage the work of CDM Monitoring Office; In charge of all relevant matters with the monitoring activity.
- Monitoring Section: Monitor, collect and archive the data according to the Monitoring and Management Manual.
- Audit Section: Audit the work of the Monitoring Section and execute the QC/QA procedures according to the Monitoring and Management Manual.

3. Monitoring equipments

The net electricity supplied to the grid will be monitored through the main meter M_{11} installed at the 330kV West Beidaqiao Substation and the Main meter M_{21} installed at the project site. The main meter M_{11} is bidirectional and has two-way metering, recording both exports to the grid $EG_{export,y}$ and imports from the grid $EG_{import1,y}$.

The back-up meter M_{12} is also installed at the 330kV West Beidaqiao Substation and will be used in case of the main meter is out of order.

The main meter M_{21} is to record the electricity imports from the grid ($EG_{import2,y}$) through the backup line.

Both the main meter M_{11} and the back-up meter M_{12} are in accuracy of 0.2s, the main meter M_{21} is in accuracy of 1.0. The electricity exported to the grid and imported from the grid will be cross-checked with sales receipts.

In the monitoring plan in the registered PDD, the accuracy of electricity meter M21 installed to monitor the electricity imported from the grid via the backup line 0.5 (the error will not exceed 0.5%). The accuracy of the main meter M21 actually installed is 1.0 (the error will not exceed 1.0%). For conservative, the differences between the electricity meters accuracy will be applied in determination of the electricity imported via the backup line.

The net electricity will be determined by the following formula:

$$EG_{facility,y} = EG_{export,y} - EG_{import1,y} - EG_{import2,y} \times (1+0.5\%)$$

The detail metering system please see the figure B.7.2. below:

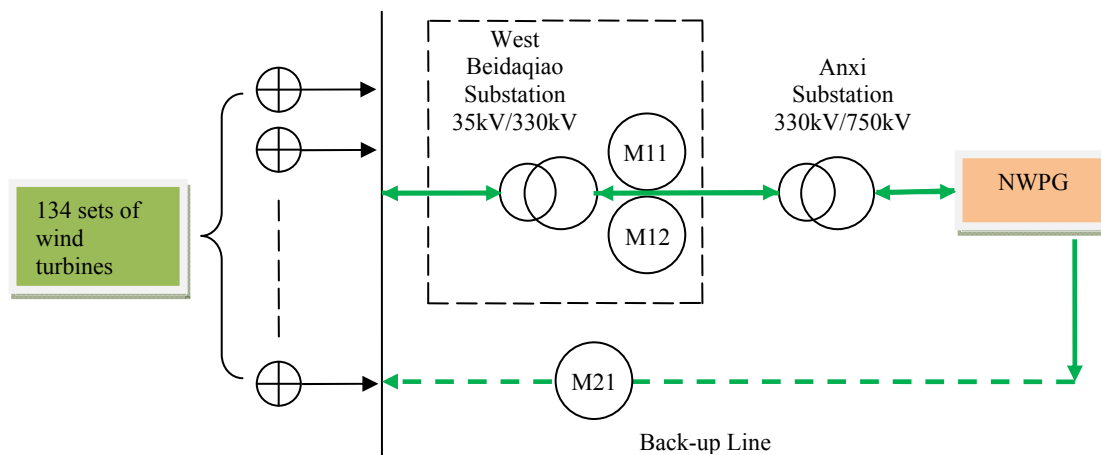

Figure B.7.2. Metering System

4. Data measurement and collection

- The main meter is read and reported to Northwest Power Grid Company monthly.
- The backup meter is read and reported monthly.



c. The project owner reports the readings, grid data and calculations to the DOE for verification.

5. QA & QC

The calibration of meters conducted by qualified organization must comply with national standard and sector regulations regularly to ensure the accuracy. The meters will be calibrated no less than once a year and must be pasted with seal after calibration. The calibration records must be archived together with other monitoring records.

If any errors are detected the party owning the meters shall repair, recalibrate or replace the meter giving the other party sufficient notice to allow a representative to attend during any corrective activity. If the readings of the main meter are beyond allowable error, the backup meter will be used; if the readings of both the main meter and the backup meter are beyond allowable error, the project owner and Power Grid Company shall jointly prepare a reasonable and conservative estimate of the correct reading. In any case there is any problem for the meters, the relevant third party is responsible to correct the meters.

After handling of the emergency, the project owner must prepare a report regarding the emergency to explain to DOE that the handling method is reasonable.

6. Data management

All monitoring data and records will be archived in electronic document. The electronic documents will be backed up in Compact Disc or Hard Disc. The project owners will also keep copies of sales receipts and prepare a monitoring report when necessary, which includes the net electricity generation, the calibration records, the emission reductions calculation and meters' corrective action records.

The monitoring data will be verified by the Office Manager once every quarter. If there is anything wrong for the data, the Office Manager will correct the data according to other meters and historical data and write the corrective action records for it.

All the electronic and paper documents will be archived during the crediting period and two years after the end of the crediting period or the last issuance of CERs, whichever occurs later.

7. Training program

The project owner will entrust the professional engineers and experts to train all the relative staffs before operation of generators. The training contains CDM knowledge, operational regulations, quality control (QC) standard flow, data monitoring requirements and data management regulations etc.

B.8 Date of completion of the application of the baseline study and monitoring methodology and the name of the responsible person(s)/entity(ies)

Date of completion: 25/11/2010

Name of persons determining the baseline study and monitoring methodology:

Contact Information of the responsible person Is organisation a Project Participant Yes/No

James Sun
Beijing MD Energy Technology Co., Ltd.
Room 11-F, Beijing City Plaza, Chaoyang Road,
Chaoyang District, Beijing, China, 100025
Tel: +86 (0)10 6556 6632
Fax: +86 (0)10 65583298

No



email: james.sun@mdenergy.cn

Website: www.mdenergy.cn

**SECTION C. Duration of the project activity / crediting period****C.1 Duration of the project activity:****C.1.1. Starting date of the project activity:**

24/10/2009 (Signing date of the EPC contract)

The starting date of a CDM project activity is the earliest of the date(s) on which the implementation or construction or real action of a project activity begins/has begun. The starting date of the proposed project activity is the date of the EPC contract, as this is the earliest date as indicated in the timeline in Section B.5.

C.1.2. Expected operational lifetime of the project activity:

22 years

C.2 Choice of the crediting period and related information:**C.2.1. Renewable crediting period****C.2.1.1. Starting date of the first crediting period:**

01/12/2011 or the date on which a complete request for registration is submitted, whichever is earlier.

C.2.1.2. Length of the first crediting period:

7 years

C.2.2. Fixed crediting period:

Not applicable

C.2.2.1. Starting date:**C.2.2.2. Length:**

**SECTION D. Environmental impacts****D.1. Documentation on the analysis of the environmental impacts, including transboundary impacts:**

The EIA of the proposed project was completed by Resource and Environment & Quality Evaluation Research Center of Lanzhou University and approved by Gansu Environmental Protection Administration. The summary of this evaluation is as following:

1. Noise

The noises will be produced by the constructing equipments and transporting vehicle during construction period. The construction will be arranged by daylight mostly, and there is no residential area and industrial and mining enterprises a few kilometres around the project site, so the constructing noise will not interrupt the residents and the noise will disappear when the project finishes construction. The measurements as arranging the transport time reasonably, limited the speed and no tooting of the vehicles in some environmental sensitive area will be carried out to reduce the noise impact of the transporting vehicle. The low-noise wind turbines will be employed to reduce the noise impact during operation period.

2. Air Pollution

The Powder and dust produced in the constructing process are the main factor for the air pollution during construction period. Sprinkling, covering the raw material and so on will be carried out to reduce the impact to lowest. The tail gas of transporting vehicles and constructing equipments will impact on part environment, but the impact will be over when the project finishes construction.

3. Wastewater

The wastewater during construction period involves equipment washing wastewater and domestic sewage. The evaporation tank will be built to treat the wastewater. When the project finishes construction, the evaporation tank will be buried. In the operation period, the domestic sewage will be drained into the water storage pit after treatment. Then it will be used for factory virescence. Therefore, there is no impact on the water environment.

4. Solid waste

The solid wastes include living garbage and construction garbage during construction period. The solid waste will be transported to the Guazhou County landfill. The smeary solid wastes will be set on fire or collected to treat. When the project finishes construction, the solid waste will be cleaned in time. The oilskin will be collected and sent to the hazardous waste treatment and disposal company during the operation period, so it will not impact on the environment.

5. Ecological environment

The impact on the ecological environment is mainly happened during construction period. The excavation, transport and the storage of equipments and materials will lead to the destruction of vegetation and changes of earth's surface structure. The construction area will be strictly arranged and will carry out the environment protecting and recovery measurements.

The project site is in the Gobi desert which is not the birds migrating channel, so there is no harm for the birds.

6. Conclusion

After the above measurements performed, the negative impacts on environment will be minimized below the requirements of laws and regulations during the construction and operation periods. Furthermore, as



renewable power project, the proposed project can reduce the consumption of fossil fuel sources and GHG emission. Besides, the project will become the special scenery in the Gobi desert and will improve the development of the local tourism.

D.2. If environmental impacts are considered significant by the project participants or the host Party, please provide conclusions and all references to support documentation of an environmental impact assessment undertaken in accordance with the procedures as required by the host Party:

According to EIA, no significant environmental impacts are discovered by the project participants or the host party. Gansu Environmental Protection Administration has approved the EIA in 6 Aug. 2008.

**SECTION E. Stakeholders' comments****E.1. Brief description how comments by local stakeholders have been invited and compiled:**

To ensure the sustainability of the proposed project which is one of the key requirements of CDM project, the project owner has carried out a stakeholder investigation around the project site in April, 2009. The stakeholder investigating summary is shown as below:

In 28 April 2009, a public stakeholder consultation was held by the developer. The proposed project and the CDM procedures were introduced in detail to the publics on the meeting, and 45 questionnaires were distributed and 43 of the distributed questionnaires had been returned. The meeting participants includes: residents in the neighbouring area, governmental officials, staff from the project owner company, and other related persons.

The questions in the questionnaires including:

- What do you think is there any air pollution/water pollution /noise/electromagnetic interference? If any, what's the extent?
- What do you think the influence on the conditions of the local ecosystem?
- What do you think the influence on your life and income?
- What do you think the influence on local employment?
- What do you think the influence on local power distribution?
- What do you think the influence on the local economic development?
- From the perspective of environmental protection and residents' interest, do you have any suggestions about the project construction and operation?

E.2. Summary of the comments received:

Comments from the questionnaires

50 questionnaires had been delivered and 50 of them had been collected, 90% support the construction of the proposed project; other 5% shows that they are indifferent to the construction of the project. Over 95% think the positive influences will be brought to the local economic/social/cultural development.

E.3. Report on how due account was taken of any comments received:

The residents and local government are all very supportive to the proposed project. No negative comments have been received on the proposed project. The result of the stakeholder investigation with answers to the mainly cared issues was put up in the neighbouring area lasted for one month, and no objection or any more comments have been received.

**Annex 1****CONTACT INFORMATION ON PARTICIPANTS IN THE PROJECT ACTIVITY**

Organization:	Hydrochina Guazhou Wind Power Co., Ltd.
Street/P.O.Box:	No. 16, Nandajie St., Guazhou County, Jiuquan City, Gansu Province
Building:	3F, CIBC Building
City:	Jiuquan City
State/Region:	Gansu Province
Postfix/ZIP:	736100
Country:	China
Telephone:	+86-937-5525807
FAX:	+86-937-5525807
E-Mail:	Lzchendp@yahoo.com.cn
URL:	-
Represented by:	
Title:	General Manager
Salutation:	Mr.
Last Name:	Chen
Middle Name:	-
First Name:	Dengping
Department:	-
Mobile:	+86 15293766156
Direct FAX:	+86-937-5525807
Direct Tel:	+86-937-5525807
Personal E-Mail:	Lzchendp@yahoo.com.cn



Organization:	Macquarie Bank Limited
Street/P.O.Box:	Level 6, Ropemaker Place
Building:	28 Ropemaker Street
City:	London
State/Region:	
Postfix/ZIP:	EC2Y 9HD
Country:	United Kingdom
Telephone:	+44 203 037 2000
FAX:	+44 203 037 4301
E-Mail:	carbontrading@macquarie.com
URL:	www.macquarie.com
Represented by:	John Marlow
Title:	Head of Environmental Financial Products
Salutation:	Mr
Last Name:	Marlow
Middle Name:	
First Name:	John
Department:	Fixed Income, Currency and Commodities Group
Mobile:	+44 7786 362 069
Direct FAX:	+44 207 065 2181
Direct tel:	+44 203 037 4176
Personal E-Mail:	carbontrading@macquarie.com



Annex 2

INFORMATION REGARDING PUBLIC FUNDING

No public funding from Annex I parties are involved in this project activity.

**ANNEX 3****BASELINE INFORMATION**

Based on the approved methodology ACM0002, the “tool to calculate the emission factor for an electricity system”, and the document “2009 Baseline Emission Factors for Regional Power Grids in China” released at http://qhs.ndrc.gov.cn/qjzjz/t20090703_289357.htm on 3 July 2009, the emission factor of Northwest China Power Grid (NWPG) calculation was shown below:

The potential Emission Factors and the Average Low Caloric Values used in calculate OM and BM are as Table 1:

Table 1 the parameters of the fuels

Fuel	Emission Factor I (tc/TJ)	Average Low Caloric Value J
Raw Coal	25.8	20,908 MJ/t
Cleaned Coal	25.8	26,344 MJ/t
Other Washed Coal	25.8	8,363 MJ/t
Briquette	26.6	20,908 MJ/t
Coke	29.2	28,435 MJ/t
Coke Oven Gas	12.1	16,726 MJ/km ³
Other Gas	12.1	5,227 MJ/km ³
Crude Oil	20.0	41,816 MJ/t
Gasoline	18.9	43,070 MJ/t
Kerosene	19.6	43,070 MJ/t
Diesel Oil	20.2	42,652 MJ/t
Fuel Oil	21.1	41,816 MJ/t
LPG	17.2	50,179 MJ/t
Refinery Gas	15.7	46,055 MJ/t
Natural Gas	15.3	38,931 MJ/km ³
Other Petroleum Products	20.0	38,369 MJ/t
Other Coking Products	25.8	28,435 MJ/t

Sources: Emission Factor: “2006 IPCC Guidelines for National Greenhouse Gas Inventories” Volume 2 Energy, Chapter 1, P1.21 – P1.24, Table 1.3 and Table 1.4.

Average Low Caloric Value: “China Energy Statistical Yearbook 2008”

Step1. Calculate the operation margin emission factor

As shown in table 1, NWPG is a coal-fired dominated power grid, where the installed capacity of low cost / must run plants account for 18.77%, 20.99%, 27.44%, 23.05% and 22.43% in 2003, 2004, 2005, 2006 and 2007 respectively, much lower than 50%. So method (a): Simple OM was chosen to calculate operating margin (OM).

Table 2 Electricity Generation of Northwest China Power Grid (2003-2007)

Year	electricity generation(10 ⁸ kWh)					Total	percentage of low cost/must run projects
	hydro	thermal	Nuclear	Wind	Others		
2003	258.99	1130.93	0.00	0.00	2.42	1392.35	18.77%
2004	348.13	1319.39	0.00	0.00	7.05	1692.53	20.99%
2005	428.01	1339.09	0.00	0.00	78.52	1845.62	27.44%



2006	480.00	1640.00	0.00	5.00	6.30	2131.00	23.05%
2007	533.00	1893.00	0.00	8.60	5.60	2440.00	22.43%

Sources: China Electric Power Yearbook 2004-2008

As said previously, Option (C) was chosen to calculate the Operating Margin Emission Factor ($EF_{grid,OM,y}$) as bellows:

Table 3 Calculating CO₂ Emission of North China Power Grid in 2005

Fuel	Unit	Shaanxi	Gansu	Qinghai	Ningxia	Xinjiang	Total	CO ₂ Emission (tCO ₂ e)
		A	B	C	D	E	G=A+B+C+D+E	$K=F \times I \times J / 1000$ (mass) $K=F \times I \times J / 100$ (Volume)
Raw Coal	10 ⁴ t	2461.28	1597	345.1	1467.7	1358.09	7229.17	131,951,756
Cleaned coal	10 ⁴ t	16.22					16.22	373,033
Other Washed Coal	10 ⁴ t	35.56			101.95	10.2	147.71	1,078,416
Coke	10 ⁴ t	3.23					3.23	87,896
Coke Oven Gas	10 ⁸ m ³						0	0
Other Gas	10 ⁸ m ³						0	0
Crude Oil	10 ⁴ t					0.18	0.18	5,352
Gasoline	10 ⁴ t	0.02				0.01	0.03	872
Diesel Oil	10 ⁴ t	2.24	0.46	0.06		0.5	3.26	100,947
Fuel Oil	10 ⁴ t	0.01	0.57			0.25	0.83	26,204
LPG	10 ⁴ t						0	0
Refinery Gas	10 ⁴ t					7.71	7.71	171,151
Natural Gas	10 ⁸ m ³	1.46	0.52	1.33		7.81	11.12	2,350,716
Other Petroleum Products	10 ⁴ t						0	0
Other Coking Products	10 ⁴ t						0	0
Other Energy	10 ⁴ tce	8.24	1.3				9.54	0
Total						136,146,341		

Sources: China Energy Statistical Yearbook 2006

Table 4 Electricity Generation of Northwest China Power Grid in 2005

Province	Electricity generation of fuel-fired power plants (MWh)	Auxiliary power ratio (%)	Total Electricity Supplied to the Grid (MWh)
Shaanxi	41100000	7.16	38,157,240
Gansu	33106000	4.23	31,705,616
Qinghai	5500000	2.69	5,352,050
Ningxia	27643000	5.73	26,059,056
Xinjiang	26560000	8.8	24,222,720
Total			125,496,682

Sources: China Electric Power Yearbook 2006



Table 5 Calculating CO₂ Emission of Northwest China Power Grid in 2006

Fuel	Unit	Shaanxi	Gansu	Qinghai	Ningxia	Xinjiang	Total	CO ₂ Emission (tCO ₂ e)
		A	B	C	D	E	G=A+B+C+D+E	K=F×I×J/1000 (mass) K=F×I×J/100 (Volume)
Raw Coal	10 ⁴ t	2834.44	1660.92	421.86	1833.72	1547.69	8298.63	151,472,271
Cleaned coal	10 ⁴ t						0	0
Other Washed Coal	10 ⁴ t				112.7	8.45	121.15	884,504
Coke	10 ⁴ t				0.01		0.01	272
Coke Oven Gas	10 ⁸ m ³	0.2				0.08	0.28	17,469
Other Gas	10 ⁸ m ³	0.1					0.1	1,950
Crude Oil	10 ⁴ t					0.02	0.02	595
Gasoline	10 ⁴ t	0.01					0.01	291
Diesel Oil	10 ⁴ t	1.14	0.24	0.61		1.25	3.24	100,328
Fuel Oil	10 ⁴ t		0.6			0.11	0.71	22,415
LPG	10 ⁴ t						0	0
Refinery Gas	10 ⁴ t						0	0
Natural Gas	10 ⁸ m ³	1.59	0.56	1.06		7.49	10.7	2,261,930
Other Petroleum Products	10 ⁴ t						0	0
Other Coking Products	10 ⁴ t	1.86					1.86	50,615
Other Energy	tce	33.57	8.81			2.2	44.58	0
Total						154,812,639		

Sources: China Energy Statistical Yearbook 2007

Table 6 Electricity Generation of Northwest China Power Grid in 2006

	Electricity generation of fuel-fired power plants (MWh)	Auxiliary power ratio (%)	Total Electricity Supplied to the Grid (MWh)
Shaanxi	54482000	6.97	50,684,605
Gansu	35738000	4.29	34,204,840
Qinghai	7204000	2.57	7,018,857
Ningxia	36731000		36,731,000
Xinjiang	29901000	8.02	27,502,940
Total			156,142,241

Sources: China Electric Power Yearbook 2007

Table 7 Calculating CO₂ Emission of Northwest China Power Grid in 2007

Fuel	Unit	Shaanxi	Gansu	Qinghai	Ningxia	Xinjiang	Total	CO ₂ Emission (tCO ₂ e)
		A	B	C	D	E	G=A+B+C+D+E	K=F×I×J/1000



							C+D+E	(mass) K=F×I×J/100 (Volume)
Raw Coal	10 ⁴ t	3303.44	1969.03	470.85	2165.8	1762.11	9671.23	176,525,905
Cleaned coal	10 ⁴ t						0	0
Other Washed Coal	10 ⁴ t	3.73			124.31	7.73	135.77	991,243
Briquettes	10 ⁴ t	3.53					3.53	64,432
Coke	10 ⁴ t						0	0
Coke Oven Gas	10 ⁸ m ³	0.52	0.65			0.26	1.43	89,215
Other Gas	10 ⁸ m ³	14.14	0.71				14.85	289,526
Crude Oil	10 ⁴ t					0.09	0.09	2,676
Gasoline	10 ⁴ t	0.02					0.02	581
Diesel Oil	10 ⁴ t	1.12	0.26	0.42		1.77	3.57	110,546
Fuel Oil	10 ⁴ t	0.01	1.05	0.04		0.05	1.15	36,307
LPG	10 ⁴ t						0	0
Refinery Gas	10 ⁴ t					5.99	5.99	132,969
Natural Gas	10 ⁸ m ³	1.68	0.49	1.93		8.66	12.76	2,697,404
Other Petroleum Products	10 ⁴ t						0	0
Other Coking Products	10 ⁴ t						0	0
Other Energy	10 ⁴ tce	94.36	9.73				104.09	0
Total								180,940,805

Sources: China Energy Statistical Yearbook 2008

Table 8 Electricity Generation of Northwest China Power Grid in 2007

	Electricity generation of fuel-fired power plants (MWh)	Auxiliary power ratio (%)	Total Electricity Supplied to the Grid (MWh)
Shaanxi	59,100,000	6.77	55,098,930
Gansu	42,400,000	5.89	39,902,640
Qinghai	9,700,000	7.19	9,002,570
Ningxia	43,500,000		43,500,000
Xinjiang	34,600,000	9.2	31,416,800
Total			178,920,940

Sources: China Energy Statistical Yearbook 2008

Weighted average calculating the Electricity Supplied and Fuel Emission in 2005-2007, the *ante* Operating Margin Emission Factor during the first crediting period is:

$$EF_{grid,OM,simple} = 1.0246 \text{ tCO}_2\text{e/MWh}$$

**Step 2. Calculate the build margin emission factor***Sub-step 1. Calculating the percentages of CO₂ emissions from the coal-fired, oil-fired and gas-fired power plants in total fuel-fired CO₂ emissions.***Table 9 the percentages of CO₂ emissions from the coal-fired, oil-fired and gas-fired power plants in total fuel-fired CO₂ emissions**

Fuel	Unit	Shaanxi	Gansu	Qinghai	Ningxia	Xinjiang	Total	Average Low Caloric Value	Emission Factor	CO ₂ Emission (tCO ₂ e)
		A	B	C	D	E	F=A+B+C+D+E	G	H	J=F*G*H*44/12/100
Raw Coal	A	B	C	D	E	F=A+...+E	G	H	I	K=F×G×H×I/100,000
Cleaned Coal	3,303.44	1,969.03	470.85	2,165.8	1,762.11	9,671.23	20,908	87,300	1	176,525,905
Other Washed Coal	0	0	0	0	0	0	26,344	87,300	1	0
Briquette	3.73	0	0	124.31	7.73	135.77	8,363	87,300	1	991,243
Coke	3.53	0	0	0	0	3.53	20,908	87,300	1	64,432
Other Coking Products	0	0	0	0	0	0	28,435	95,700	1	0
Subtotal							177,581,580			
Crude Oil	0	0	0	0	0.09	0.09	41,816	71,100	1	2,676
Gasoline	0.02	0	0	0	0	0.02	43,070	67,500	1	581
Diesel Oil	1.12	0.26	0.42	0	1.77	3.57	42,652	72,600	1	110,546
Fuel Oil	0.01	1.05	0.04	0	0.05	1.15	41,816	75,500	1	36,307
Other Petroleum Products	0	0	0	0	0	0	41,816	75,500	1	0
Subtotal							150,110			
Natural Gas	16.8	4.9	19.3	0	86.6	127.6	38,931	54,300	1	2,697,404
Coke Oven Gas	5.2	6.5	0	0	2.6	14.3	16,726	37,300	1	89,215
Other Gas	141.4	7.1	0	0	0	148.5	5,227	37,300	1	289,526
LPG	0	0	0	0	0	0	50,179	61,600	1	0
Refinery Gas	0	0	0	0	5.99	5.99	46,055	48,200	1	132,969
Subtotal							3,209,114			
Total							180,940,805			

Sources: China Energy Statistical Yearbook 2007

The result from the above table:

$$\lambda_{Coal,y} = 98.14\%$$

$$\lambda_{Oil,y} = 0.08\%$$

$$\lambda_{Gas,y} = 1.77\%$$

**Sub-step 2. Calculating the fuel-fired emission factor**

$$EF_{Thermal,y} = \lambda_{Coal,y} \times EF_{Coal,Adv,y} + \lambda_{Oil,y} \times EF_{Oil,Adv,y} + \lambda_{Gas,y} \times EF_{Gas,Adv,y}$$

Where:

$EF_{Thermal}$ is the fuel-fired emission factor;

$EF_{Coal,Adv}$, $EF_{Oil,Adv}$ and $EF_{Gas,Adv}$ are corresponding to the emission factors of coal, oil and gas fired power plants which are applied by the most advanced commercialized technologies.

Table 10 Emission factors of Coal, Oil and Gas with the most advanced commercialized technologies applied by the fuel-fired power plants

	Parameters	Fuel consumption rate (%)	Fuel Emission Factor(tc/TJ)	Emission Factor (tCO ₂ /MWh)
		A	B	D=3.6/A/1,000,000×B
Coal-fired plant	$EF_{Coal,Adv}$	38.10	87,300	0.8249
Gas-fired plant	$EF_{Gas,Adv}$	49.99	75,500	0.5437
Oil-fired plant	$EF_{Oil,Adv}$	49.99	54,300	0.3910

Sources: 2009 Baseline Emission Factors for Regional Power Grids in China, NRDC.

Then, calculating

$$EF_{Thermal,y} = \lambda_{Coal,y} \times EF_{Coal,Adv,y} + \lambda_{Oil,y} \times EF_{Oil,Adv,y} + \lambda_{Gas,y} \times EF_{Gas,Adv,y} = 0.8170 \text{ tCO}_2/\text{MWh}$$

Sub-step 3. Calculating the Build Margin Emission Factor.

$$EF_{grid,BM,y} = \frac{CAP_{Thermal}}{CAP_{Total}} \times EF_{Thermal}$$

Where:

$EF_{BM,y}$ = the Build Margin emission factor with advanced commercialized technologies for year y;

CAP_{Total} = the new capacity additions;

$CAP_{Thermal}$ = the new fuel-fired capacity additions.

Table 11 Installed Capacities of the Northwest China Power Grid 2007

Installed Capacity	Unit	Shaanxi	Gansu	Qinghai	Ningxia	Xinjiang	Total
Fuel-fired	MW	12,290	7,840	1,900	7,030	6,560	35,620
Hydro	MW	1,790	4,400	5,830	430	2,140	14,590
Nuclear	MW	0	0	0	0	0	0
Wind & Others	MW	72.5	346	0	50	330	798.5
Total	MW	14,152.5	12,586	7,730	7,510	9,030	51,008.5

Sources: China Electric Power Yearbook 2008

**Table 12 Installed Capacities of the Northwest China Power Grid 2006**

Installed Capacity	Unit	<u>Shaanxi</u>	<u>Gansu</u>	<u>Qinghai</u>	<u>Ningxia</u>	<u>Xinjiang</u>	Total
Fuel-fired	MW	9,723	6,448	1,517	6,002	5,937	29,627
Hydro	MW	2,165	4,291	5,423	429	1,766	14,074
Nuclear	MW	0	0	0	0	0	0
Wind & Others	MW	0	199	0	11	189	399
Total	MW	11,888	10,938	6,940	6,442	7,892	44,100

Sources : China Electric Power Yearbook 2007

Table 13 Installed Capacities of the Northwest China Power Grid 2005

Installed Capacity	Unit	<u>Shaanxi</u>	<u>Gansu</u>	<u>Qinghai</u>	<u>Ningxia</u>	<u>Xinjiang</u>	Total
Fuel-fired	MW	9,132.1	5,715	886.8	4,577	5,051.7	25,362.6
Hydro	MW	1,578	4,036.2	4,825	428.5	1,352.1	12,219.8
Nuclear	MW	0	0	0	0	0	0
Wind & Others	MW	46	109.1	0	112.2	132.2	399.5
Total	MW	10,756.1	9,860.3	5,711.8	5,117.7	6,536	37,981.9

Sources : China Electric Power Yearbook 2006

Table 14 Change Installed Capacity from 2005-2007

	Year 2005	Year 2006	Year 2007	2005-2007 New Capacity	Percentage of New Capacity Additions
	A	B	C	D=C-B	
Fuel-fired (MW)	25,362.6	29,627	35,620	10,257.4	78.74%
Hydro (MW)	12,219.8	14,074	14,590	2,370.2	18.20%
Nuclear (MW)	0	0	0	0	0.00%
Wind (MW)	399.5	399	798.5	399	3.06%
Total	37,981.9	44,100	51,008.5	13,026.6	100.00%
Percentage of Year 2007	74.46%	86.46%	100%		

Then, the result is $EF_{BM,y} = EF_{grid,BM,y} = \frac{CAP_{Thermal}}{CAP_{Total}} \times EF_{Thermal} = 0.8170 \times 78.74\% = 0.6433 \text{ tCO}_2/\text{MWh}$

Step 3. calculate the combined margin Emission Factor ($EF_{grid,CM,y}$)

$$EF_{grid,CM,y} = 0.75 \times EF_{grid,OM,y} + 0.25 \times EF_{grid,BM,y} = 0.75 \times 1.0246 + 0.25 \times 0.6433 = 0.92928 \text{ tCO}_2e/\text{MWh}$$



Annex 4

MONITORING INFORMATION

/