



Verified Carbon Standard

GUOHUA RONGCHENG PHASE III WIND FARM PROJECT

Document Prepared by

Guohua Energy Investment Co., Ltd.

Contact Information

Project Title	Guohua Rongcheng Phase III Wind Farm Project
Version	02
Report ID	Rongcheng-1304-3
Date of Issue	15-November-2022
Project ID	1304
Monitoring Period	01-February-2014 to 31-January-2018
Prepared By	Guohua Energy Investment Co., Ltd.
Contact	Address: No. 3 of Dongzhimen South Street, Dongcheng District, Beijing Email: 20005222@ceic.com Website: http://ghtz.shenhuagroup.com.cn

CONTENTS

1	PROJECT DETAILS.....	3
1.1	Summary Description of the Implementation Status of the Project	3
1.2	Sectoral Scope and Project Type	3
1.3	Project Proponent	4
1.4	Other Entities Involved in the Project	4
1.5	Project Start Date	4
1.6	Project Crediting Period	4
1.7	Project Location	5
1.8	Title and Reference of Methodology	5
1.9	Participation under other GHG Programs.....	5
1.10	Other Forms of Credit.....	5
1.11	Sustainable Development Contributions	6
2	SAFEGUARDS	9
2.1	No Net Harm	9
2.2	Local Stakeholder Consultation	9
2.3	AFOLU-Specific Safeguards	10
3	IMPLEMENTATION STATUS	10
3.1	Implementation Status of the Project Activity	10
3.2	Deviations	10
3.3	Grouped Projects	11
4	DATA AND PARAMETERS.....	11
4.1	Data and Parameters Available at Validation	11
4.2	Data and Parameters Monitored.....	11
4.3	Monitoring Plan.....	14
5	QUANTIFICATION OF GHG EMISSION REDUCTIONS AND REMOVALS	15
5.1	Baseline Emissions	16
5.2	Project Emissions	21
5.3	Leakage.....	21
5.4	Net GHG Emission Reductions and Removals.....	21

1 PROJECT DETAILS

1.1 Summary Description of the Implementation Status of the Project

The purpose of the report is to calculate the emission reductions generated by Guohua Rongcheng Phase III Wind Farm Project (thereafter referred to the project) during the monitoring period (01/02/2014 to 31/01/2018), and to serve as basis for the verification and issuance of corresponding VCUs.

The Project, developed by Guohua Resourceful (Rongcheng) Wind Power Generation Co., Ltd., involves construction and operation of a wind power project that is sited in Chengshan Town, Rongcheng City, Shandong Province, People's Republic of China. The construction start date for the project is 01/12/2009. The first power unit started operation on 17/10/2010, and all the wind turbine generators were put into operation on 19/12/2010. The Project has been registered as a CDM project on 19/07/2012 (UNFCCC registration reference number: 6580).

The total installed capacity of the Project is 49.5MW consisting of 33 sets of wind turbine with unit capacity of 1.5MW. The electricity generated by the Project is delivered to the North China Power Grid (NCPG). The scenario existing prior to the start of the implementation of the project is the same as the baseline scenario, i.e. electricity would have otherwise been generated by the operation of existing power plants connected to NCPG and by the addition of new generation sources of NCPG. After the project is put into operation, the power generated will replace a part of power supply in NCPG which is dominated by fuel-fired power plants and thus reduce greenhouse gas (GHG) emission through avoiding CO₂ emissions produced by NCPG. The estimated annual emission reductions are 89,823 tCO₂e during the first crediting period.

During this monitoring period (01/02/2014 to 31/01/2018), the monitoring activities were conducted strictly in accordance with the monitoring plan contained in the registered CDM-PDD. The Project has operated without any accidental or emergency events that might impact the accuracy and/or implementation of monitoring activities during this monitoring period. The net power supply during this monitoring period is 403,987.470 MWh. The total emission reductions in this monitoring period (01/02/2014 to 31/01/2018) are 361,920 tCO₂e.

1.2 Sectoral Scope and Project Type

Sectoral scope 1: Energy industries (renewable/non-renewable sources)

Project type: Grid-connected wind power project.

The project is not a grouped project.

1.3 Project Proponent

Organization name	Guohua Resourceful (Rongcheng) Wind Power Generation Co., Ltd.
Contact person	Mr. Hu Weiping
Title	Project manager
Address	No. 3 of Dongzhimen South Street, Dongcheng District, Beijing
Telephone	010-58151719
Email	20005222@ceic.com

1.4 Other Entities Involved in the Project

Organization name	N/A
Role in the Project	N/A
Contact person	N/A
Title	N/A
Address	N/A
Telephone	N/A
Email	N/A

1.5 Project Start Date

17/10/2010, on which the VCS project began reducing GHG emissions.

1.6 Project Crediting Period

17/10/2010 - 16/10/2020, 1st renewable crediting period which covers 10 years.

There is a deviation for the crediting period. The project is registered under VCS Standard 3.4 and completed validation before 19/03/2020, thus it remains eligible to apply the crediting period requirements under VCS Version 3 which shall be a maximum of ten years and may be renewed at most twice, so the first renewable crediting period of the project shall be updated from 17/10/2010-18/07/2012 to 17/10/2010 - 16/10/2020. Besides, since the project has been registered under CDM, and is not eligible for VCU issuance beyond the end of the total project crediting period under CDM (31/07/2033). However the project lifetime is 20 years. Therefore the project crediting life would be 17/10/2010 - 16/10/2030.

1.7 Project Location

The Project is located in Chengshan Town, Rongcheng City, Shandong Province, People's Republic of China, and the geographical coordinates are 121° 11'-122° 42' east longitude and 36° 41'-37° 35' north latitude.

1.8 Title and Reference of Methodology

Approved consolidated baseline and monitoring methodology ACM0002.version 12.3.0- "Consolidated baseline methodology for grid-connected electricity generation from renewable sources"

The methodology also refers to the approved versions for the following tools:

- Tool for the demonstration and assessment of additionality version 05.2.1;
- Tool to calculate the emission factor for an electricity system version 02.2.1

Reference:

<http://cdm.unfccc.int/methodologies/PAmethodologies/approved.html>

1.9 Participation under other GHG Programs

The Project was registered as a CDM project on 19/07/2012 (Ref. 6580). The first CDM crediting period is from 01/08/2012 to 31/07/2019. CERs of 133,851tCO₂e have been issued for the monitoring period from 01/08/2012 to 31/01/2014. The emission reductions during this monitoring period (01/02/2014 to 31/01/2018) will only apply for issuance under VCS, which is ensured by the statement that the PP will not request the issuance of CERs under CDM and the VCs will not be double counted.

The project claimed the pre-CDM VCs during the monitoring period from 17/10/2010 to 18/07/2012. There is a gap between this pre-CDM monitoring period and the 1st CDM monitoring period (01/08/2012 to 31/01/2014). The project proponent waived the issuance during this gap from 19/07/2012 to 01/08/2012 and claimed the CERs of the period 01/08/2012 to 31/01/2014. There is NO gap between the CDM monitoring period from 01/08/2012 to 31/01/2014 and this VCS monitoring period from 01/08/2012 to 31/01/2014.

1.10 Other Forms of Credit

Emission Trading Programs and Other Binding Limits

China has a national emissions trading scheme only cover the high-emission industries, such as thermal power generation, petrochemical, chemical, building materials, iron and steel, non-

ferrous, paper, aviation and other key emission industries that emitted at least 26,000 tons of CO₂e/year, not including renewable project¹.

Thus, the project proponent: Guohua Resourceful (Rongcheng) Wind Power Generation Co., Ltd. as an enterprise for renewable energy investment, is not included in the compliance entity list by China national Emission Trading Scheme (ETS). Moreover, the project has not been registered as a CCER (Chinese Certified Emission Reductions) project in China, thus it is not eligible for emission reductions transaction under the China's ETS.

Therefore, the project does not reduce GHG emissions from activities that are included in an emissions trading program or any other mechanism that includes GHG allowance trading. The net GHG emission reductions generated during this monitoring period have not been used for compliance under such programs or mechanisms. Furthermore, a statement on no double counting will be submitted to Verra to confirm the credits during this monitoring period has not been counted and will not be counted under emission trading programs and other binding limits.

Other Forms of Environmental Credit

The project has not sought or received another form of GHG-related environmental credit, including renewable energy certificates, during this monitoring period.

1.11 Sustainable Development Contributions

The Project activity will not only supply renewable electricity to grid, but also contribute to sustainable development of the local community, which mainly include the following:

- The project utilizes wind resources to generate and supplied 403,987.470MWh renewable electricity to the power grid during this monitoring period, which contributes to SDG 7.
- The project provides 15 long-term job opportunities for local residents during this monitoring period, which has a positive effect on the local economy which contributes to SDG 8.
- The project utilizes zero-emission wind power to supply electricity to the grid, and reduces 361,920 tCO₂e of GHG emissions during this monitoring period, which contributes to SDG 13.

For evidence of SDGs, please refer to Appendix 1 for details.

¹ http://www.mee.gov.cn/xxgk/2018/xxgk/xxgk05/202103/t20210330_826728.html

Table 1: Sustainable Development Contributions

Row number	SDG Target	SDG Indicator	Net Impact on SDG Indicator	Current Project Contributions	Contributions Over Project Lifetime
1)	7.2	7.2.1 Renewable energy share in the total final energy consumption	Implemented activities to increase	The project has provided 403,987.470 MWh renewable energy generation during this monitoring period.	This is the first time to report sustainable development contributions of the project. The project has provided 403,987.470 MWh renewable energy generation accumulated at the end of this monitoring period.

2)	8.5	8.5.1 Average hourly earnings of employees, by sex, age, occupation and persons with disabilities	Implemented activities to increase	<p>The project has employed 15 persons including 12 men and 3 women during this monitoring period with yearly average salary higher than the local average salary of the respective years (http://tjj.weihai.gov.cn/col/col13261/index.html).</p> <table border="1" data-bbox="999 560 1392 1125"> <thead> <tr> <th>Year</th> <th>Average yearly salary of the project (CNY)</th> <th>Local average salary (CNY)</th> </tr> </thead> <tbody> <tr> <td>2014</td> <td>81,133</td> <td>48,476</td> </tr> <tr> <td>2015</td> <td>87,458</td> <td>53,494</td> </tr> <tr> <td>2016</td> <td>93,235</td> <td>57,812</td> </tr> <tr> <td>2017</td> <td>101,124</td> <td>62,344</td> </tr> <tr> <td>2018</td> <td>105,294</td> <td>66,733</td> </tr> </tbody> </table>	Year	Average yearly salary of the project (CNY)	Local average salary (CNY)	2014	81,133	48,476	2015	87,458	53,494	2016	93,235	57,812	2017	101,124	62,344	2018	105,294	66,733	Employed about 15 persons yearly.
Year	Average yearly salary of the project (CNY)	Local average salary (CNY)																					
2014	81,133	48,476																					
2015	87,458	53,494																					
2016	93,235	57,812																					
2017	101,124	62,344																					
2018	105,294	66,733																					
3)	13.0	Tonnes of greenhouse gas emissions avoided or removed	Implemented activities to increase	By supplying 403,987.470 MWh renewable energy to the grid, the project has prevented the release of 361,920 tonnes of carbon into the atmosphere during the monitoring period.	This is the first time to report sustainable development contributions of the project. the project prevented the release of 361,920 tonnes of carbon into the atmosphere accumulated at the end of this monitoring period.																		

2 SAFEGUARDS

2.1 No Net Harm

In accordance with relevant laws and regulations on environmental protection, an Environmental Impact Assessment (EIA) of the proposed project has been implemented. The results of the EIA have been approved by the Environmental Protection Bureau of Shandong Province.

The EIA has assessed every possible aspect of environmental impacts of the project and recommended corresponding measures, where applicable. The environmental impacts and corresponding mitigation measures during operation have been discussed in the registered CDM-PDD. No negative environmental impacts have been identified.

Furthermore, the project makes positive contributions to the sustainable development as described in section 1.11 of this report e.g., providing job opportunities and clean energy to the local community, and mitigating GHG emissions.

In conclusion, construction and operation of the project does not cause any negative environmental nor socio-economic impacts.

2.2 Local Stakeholder Consultation

LSC prior to the project implementation

A public survey was conducted in December 2008 by the project owner. Questionnaires were distributed to the stakeholders in the directly affected area, requesting comments on the proposed project construction. As there are few people living around the wind farm project site, 30 copies of questionnaire were distributed and 30 copies of the questionnaire were returned. Most of the local residents knew about wind power projects and all of them held positive and supportive attitude towards the construction of the proposed project. They hope that the project can be put into operation as soon as possible.

An invitation notice for stakeholder comments was issued by the project developer, and several representatives of local stakeholders, including governmental officials of local county and local residents, etc attended the meeting on 13/12/2008 to discuss the questionnaires collected and further introduce the project. No negative opinion on construction of the project is heard and environmental considerations expressed by stakeholders are discussed on the meeting.

LSC during the operation period

During this monitoring period, the project carried out the communication with local stakeholders in line with the on-going communication mechanism, i.e.,

The project owner published the contact information of the contact person who is responsible for stakeholders' comments to the local government and residents. Stakeholders were informed of the contact information, and their comments can be directly collected by the contact person. The comments would be fed back to the stakeholders by the contact person for a timely response. Besides, the contact person of project owner also meets local villagers to collect their comments and suggestions at least yearly. Actually the contact person met local villagers to collect their

comments and suggestions respectively in March 2014, March 2015, March 2016, and March 2017. Once the contact person received negative comments from the stakeholders, the contact person would record the negative comments and the feedback. The local authority also conducts spot checks on the implementation of the project at periodic intervals as per relevant regulations.

In line with VCS requirements all the processed have been implemented to receive comments from local stakeholders as well as communicate with them. By the end of this monitoring period, the project did not receive any negative comments nor grievance from the stakeholders.

2.3 AFOLU-Specific Safeguards

The project is a non-AFOLU project, and this section is not required.

3 IMPLEMENTATION STATUS

3.1 Implementation Status of the Project Activity

The total installed capacity of the Project is 49.5MW consisting of 33 sets of wind turbine with unit capacity of 1.5MW. See Table 2 below for key technical specifications.

Table 2. Major technical parameters of the key equipments of the Project

Parameter	Value
Model of wind turbine	GW82/1500
Manufacture	Xinjiang Goldwind Science & Technology Co., Ltd.
Rotor Diameter	82m
Amount of vane	3
Height of hub	70m
Cut-in wind speed	3m/s
Cut-out wind speed	22 m/s
PLF	0.231
Life time	20years

No abnormal circumstance occurred during this monitoring period. There is no event or situation occurred during the monitoring period, which may impact the applicability of the methodology and may impact the GHG emission reductions or removals and monitoring. The project was operational as normal during the monitoring period.

3.2 Deviations

3.2.1 Methodology Deviations

No methodology deviation exists.

3.2.2 Project Description Deviations

There is a deviation for the crediting period. The project is registered under VCS Standard 3.4 and completed validation before 19/03/2020, thus it remains eligible to apply the crediting period requirements under VCS Version 3 which shall be a maximum of ten years and may be renewed at most twice, so the first renewable crediting period of the project shall be updated from 17/10/2010-18/07/2012 to 17/10/2010 - 16/10/2020. Besides, since the project has been registered under CDM, and is not eligible for VCU issuance beyond the end of the total project crediting period under CDM (31/07/2033). However the project lifetime is 20 years. Therefore the project crediting life would be 17/10/2010 – 16/10/2030. This deviation is related to the change on the duration of the crediting period, which does not impact the applicability of the methodology, additionality or the appropriateness of the baseline scenario.

3.3 Grouped Projects

The Project is not a grouped project.

4 DATA AND PARAMETERS

4.1 Data and Parameters Available at Validation

Data / Parameter	EF _{grid,CM,y}
Data unit	tCO ₂ e/MWh
Description	The combined margin grid emission factor of the North China Power Grid where the Project connected to
Source of data	Registered CDM-PDD
Value applied	0.895875
Justification of choice of data or description of measurement methods and procedures applied	Determined ex-ante and fixed for the 1 st crediting period
Purpose of Data	Calculation of baseline emissions.
Comments	-

4.2 Data and Parameters Monitored

Data / Parameter	EG _{out,y}
Data unit	MWh
Description	Electricity generation supplied to the North China Power Grid by the project in year y

Source of data	Electricity meter reading
Description of measurement methods and procedures to be applied	One bidirectional meter (M) is installed at the low voltage side of onsite 110kV step-up substation at the main line to measure the Electricity generation supplied to the North China Power Grid by the project in year y
Frequency of monitoring/recording	Monthly recorded and aggregated
Value monitored	406,167.590
Monitoring equipment	See table below
QA/QC procedures to be applied	<p>Meters have been properly calibrated annually according to the requirement from Technical administrative code of electric energy metering (national standard reference: DL/T448), and in compliance with the requirement of monitoring plan. Meter readings are crosschecked with sales receipts.</p> <p>All data and records are archived during the crediting period and at least 2 years after the end of the crediting period.</p>
Purpose of the data	Calculation of baseline emissions
Calculation method	-
Comments	-

Data / Parameter	EG _{in,y}
Data unit	MWh
Description	Electricity consumed by the project which is imported from the North China Power Grid through the main line in year y
Source of data	Electricity meter reading
Description of measurement methods and procedures to be applied	One bidirectional meter (M) is installed at the low voltage side of onsite 110kV step-up substation at the main line to measure the Electricity consumed by the project which is imported from the North China Power Grid through the main line in year y
Frequency of monitoring/recording	Monthly recorded and aggregated
Value monitored	2,173.630
Monitoring equipment	See table below
QA/QC procedures to be applied	Meters have been properly calibrated annually according to the requirement from Technical administrative code of electric energy metering (national standard reference: DL/T448), and in compliance

	with the requirement of monitoring plan. Meter readings are crosschecked with sales receipts. All data and records are archived during the crediting period and at least 2 years after the end of the crediting period.
Purpose of the data	Calculation of baseline emissions
Calculation method	-
Comments	-

Data / Parameter	EG _{backup,y}
Data unit	MWh
Description	Electricity consumed by the project which is imported from the North China Power Grid through the backup line in year y
Source of data	Electricity meter reading
Description of measurement methods and procedures to be applied	The meter m is installed on the backup line to measure the Electricity consumed by the project which is imported from the North China Power Grid through the main line in year y
Frequency of monitoring/recording	Monthly recorded and aggregated
Value monitored	6.490
Monitoring equipment	See table below
QA/QC procedures to be applied	Meters have been properly calibrated annually according to the requirement from Technical administrative code of electric energy metering (national standard reference: DL/T448), and in compliance with the requirement of monitoring plan. Meter readings are crosschecked with sales receipts. All data and records are archived during the crediting period and at least 2 years after the end of the crediting period.
Purpose of the data	Calculation of baseline emissions
Calculation method	-
Comments	-

Data / Parameter	EG _{facility,y}
Data unit	MWh

Description	Quantity of net electricity generation supplied by the project to the grid in year y
Source of data	Calculation: $EG_{facility,y} = EG_{out,y} - EG_{in,y} - EG_{backup,y}$
Description of measurement methods and procedures to be applied	Calculated by $EG_{facility,y} = EG_{out,y} - EG_{in,y} - EG_{backup,y}$
Frequency of monitoring/recording	Monthly recorded and aggregated
Value monitored	403,987.470
Monitoring equipment	See table below.
QA/QC procedures to be applied	Calculated by $EG_{facility,y} = EG_{out,y} - EG_{in,y} - EG_{backup,y}$
Purpose of the data	Used for baseline emission calculation
Calculation method	Calculated by $EG_{facility,y} = EG_{out,y} - EG_{in,y} - EG_{backup,y}$
Comments	-

Table 3 Information of meters

Meter	Type	Serial No.	Accuracy	Calibration date	Valid till	Calibrator
M	Electricity meter	10030265270082	0.5	02/06/2013	01/06/2014	Center of Electricity Measurement, Weihai Power Grid Company
				28/05/2014	27/05/2015	
				22/05/2015	21/05/2016	
				13/05/2016	12/05/2017	
				04/05/2017	03/05/2018	
m	Electricity meter	10030265270067	0.5	02/06/2013	01/06/2014	
				28/05/2014	27/05/2015	
				22/05/2015	21/05/2016	
				13/05/2016	12/05/2017	
				04/05/2017	03/05/2018	

4.3 Monitoring Plan

Organization Structure

Project owner organized a special carbon project workgroup to take charge of the monitoring work of the whole project. The general manager of the project entity appointed a carbon project manager. Monitoring staff, on-site engineers and internal audit staff are responsible for the collection of the data and information required in the monitoring plan. The collected data and information is documented and sent to the carbon project manager monthly. The carbon project manager is in charge of the implementation of the monitoring plan and report to the general

manager of the project owner. The general manager makes the confirmations on monitoring, calculation data and reports.

For details regarding the management structure of the monitoring plan, please refer to Figure 1.

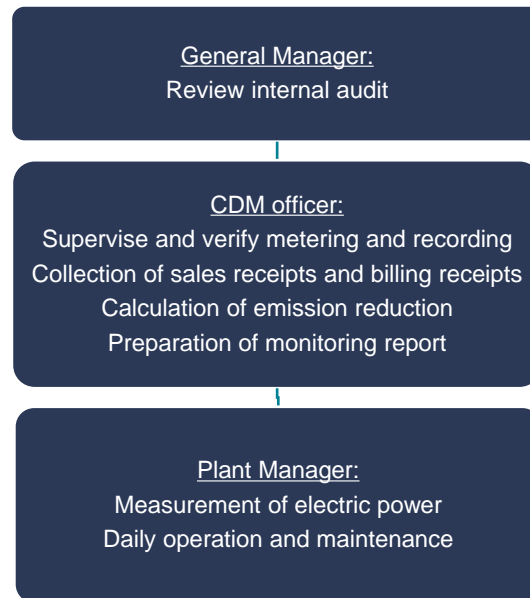

Figure 1. Management Structure of Monitoring Plan

Data collection procedures

One bidirectional meter (M) is installed at the low voltage side of onsite 110kV step-up substation at the main line to measure electricity delivered to NCPG by the project in the year y and electricity consumed by the project which is imported from the NCPG at the main line in the year y . The accuracy of the meter is 0.5 and uncertainty level of the meter does not exceed 0.5%. At the same time, a 10kv back-up line is connected for the emergency. One meter (m) with the accuracy of 1.0 is installed to measure the electricity imported from the back-up line.

Meter (M) has been properly configured and checked by both grid company and project owner. M is owned, operated and maintained by the project owner. The data of M is recorded by the project owner. The meter (m) on the back-up line is owned, operated and maintained by the grid company. The cut-off time of $EG_{out,y}$, $EG_{in,y}$ and $EG_{backup,y}$ is 24:00 of the last day of each month. On monthly basis, the grid company issues sales receipts to the project company. Sale receipts are used for double check the measured data of electricity. The conservative data between the value measured and the sales receipts will be used for the emission reduction calculation. All meters mentioned above are continuously measured and monthly recorded used to calculate the Project's net electricity delivered to the grid.

See the following figure for the monitoring points:

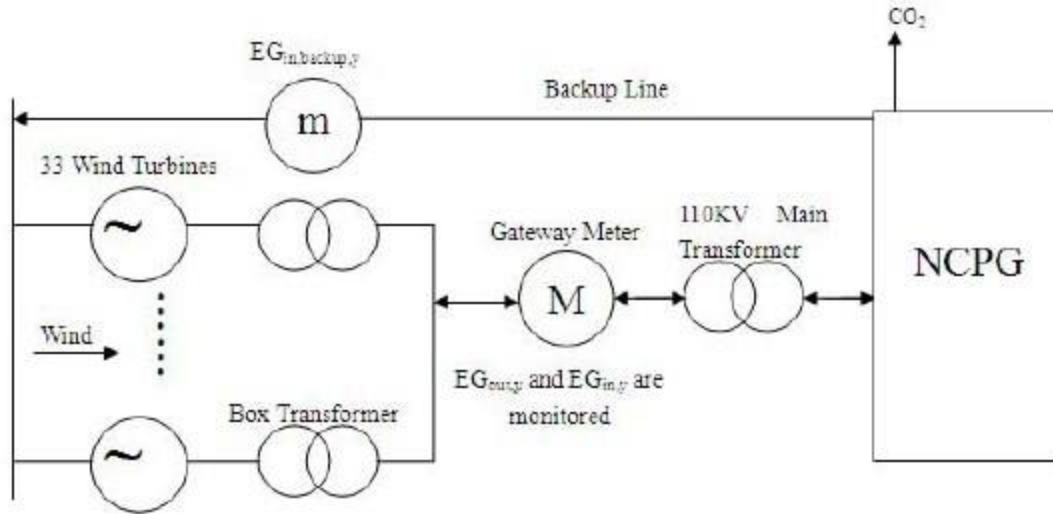

Figure 2. Monitoring points

Emergency procedures

In case of emergencies, which means that under the condition that project entity cannot monitor the main meter due to the unexpected accident, the project entity follows the following procedure: In case that the monitoring meters cannot be monitored due to the unexpected accident, the data is confirmed between the grid company and the project owner.

During this monitoring period, no emergency happened.

5 QUANTIFICATION OF GHG EMISSION REDUCTIONS AND REMOVALS

5.1 Baseline Emissions

As per the registered PD, the baseline emission of the project is calculated as below:

$$BE_y = EG_{facility,y} * EF_{grid,CM,y}$$

Table 4 Baseline emissions calculation

Year	EG _{facility,y}	EF _{grid,CM,y}	BE _y
	MWh	tCO ₂ e/MWh	tCO ₂ e
2014 (01/02/2014 to 31/12/2014)	81,750.306	0.895875	73,238

2015 (01/01/2015 to 31/12/2015)	101,455.184	0.895875	90,891
2016 (01/01/2016 to 31/12/2016)	105,920.998	0.895875	94,891
2017 (01/01/2017 to 31/12/2017)	104,152.740	0.895875	93,307
2018 (01/01/2018 to 31/01/2018)	10,708.242	0.895875	9,593
total	403,987.470	/	361,920

The monitored monthly electricity data is shown in the tables below:

Table 5 Monitoring results (MWh)

Period start	Period end	EG _{out,y}			EG _{in,y}			EG _{backup,y}			EG _{facility}
		Values from meter readings	Values from sales receipts	Conservative values	Values from meter readings	Values from sales receipts	Conservative values	Values from meter readings	Values from sales receipts	Conservative values	
01/02/2014	28/02/2014	10,656.625	10,469.000	10,469.000	36.750	37.750	37.750	0.294	0.294	0.294	10,430.956
01/03/2014	31/03/2014	10,074.750	9,873.100	9,873.100	42.000	42.640	42.640	0.000	0.000	0.000	9,830.460
01/04/2014	30/04/2014	6,210.750	6,082.400	6,082.400	26.250	27.320	27.320	0.000	0.000	0.000	6,055.080
01/05/2014	31/05/2014	10,611.125	10,463.700	10,463.700	36.750	37.750	37.750	0.702	0.702	0.702	10,425.248
01/06/2014	30/06/2014	4,706.625	4,569.600	4,569.600	63.875	65.600	65.600	1.014	1.014	1.014	4,502.986
01/07/2014	31/07/2014	5,495.000	5,354.000	5,354.000	46.375	47.520	47.520	0.000	0.000	0.000	5,306.480
01/08/2014	31/08/2014	2,835.875	2,745.600	2,745.600	91.000	92.660	92.660	0.000	0.000	0.000	2,652.940
01/09/2014	30/09/2014	3,341.625	3,282.900	3,282.900	49.000	50.560	50.560	0.000	0.000	0.000	3,232.340
01/10/2014	31/10/2014	10,462.375	10,234.600	10,234.600	24.500	24.950	24.950	0.984	0.984	0.984	10,208.666
01/11/2014	30/11/2014	7,427.875	7,326.700	7,326.700	33.250	34.580	34.580	0.000	0.000	0.000	7,292.120
01/12/2014	31/12/2014	12,105.625	11,839.300	11,839.300	25.375	26.270	26.270	0.000	0.000	0.000	11,813.030
Subtotal 2014		-	-	82,240.900	-	-	487.600	-	-	2.994	81,750.306
01/01/2015	31/01/2015	14,766.500	14,458.000	14,458.000	14.875	15.180	15.180	0.000	0.000	0.000	14,442.820
01/02/2015	28/02/2015	11,200.875	11,009.800	11,009.800	37.625	38.940	38.940	0.000	0.000	0.000	10,970.860
01/03/2015	31/03/2015	10,250.625	10,006.500	10,006.500	29.750	30.760	30.760	0.010	0.010	0.010	9,975.730
01/04/2015	30/04/2015	13,446.125	13,150.800	13,150.800	28.000	28.510	28.510	0.018	0.018	0.018	13,122.272
01/05/2015	31/05/2015	9,226.000	9,012.500	9,012.500	36.750	37.220	37.220	0.006	0.006	0.006	8,975.274
01/06/2015	30/06/2015	6,181.000	6,078.500	6,078.500	84.000	86.460	86.460	0.002	0.002	0.002	5,992.038
01/07/2015	31/07/2015	4,365.375	4,232.800	4,232.800	78.750	80.650	80.650	0.000	0.000	0.000	4,152.150
01/08/2015	31/08/2015	3,227.875	3,152.700	3,152.700	89.250	92.000	92.000	0.014	0.014	0.014	3,060.686
01/09/2015	30/09/2015	3,075.625	3,024.100	3,024.100	56.875	57.420	57.420	0.654	0.654	0.654	2,966.026

01/10/2015	31/10/2015	7,459.375	7,301.300	7,301.300	38.500	39.470	39.470	0.204	0.204	0.204	7,261.626
01/11/2015	30/11/2015	10,739.750	10,423.000	10,423.000	23.625	24.160	24.160	0.020	0.020	0.020	10,398.820
01/12/2015	31/12/2015	10,478.125	10,188.500	10,188.500	50.750	51.610	51.610	0.008	0.008	0.008	10,136.882
Subtotal 2015		-	-	102,038.500	-	-	582.380	-	-	0.936	101,455.184
01/01/2016	31/01/2016	13,881.875	13,602.100	13,602.100	20.125	20.860	20.860	0.010	0.010	0.010	13,581.230
01/02/2016	29/02/2016	9,232.125	8,992.800	8,992.800	36.750	37.620	37.620	0.020	0.020	0.020	8,955.160
01/03/2016	31/03/2016	12,882.625	12,475.100	12,475.100	28.000	28.120	28.120	0.000	0.000	0.000	12,446.980
01/04/2016	30/04/2016	8,679.125	8,491.500	8,491.500	49.875	50.950	50.950	0.046	0.046	0.046	8,440.504
01/05/2016	31/05/2016	8,425.375	8,289.200	8,289.200	51.625	53.200	53.200	0.008	0.008	0.008	8,235.992
01/06/2016	30/06/2016	6,894.125	6,760.700	6,760.700	61.250	62.960	62.960	0.000	0.000	0.000	6,697.740
01/07/2016	31/07/2016	6,013.875	5,886.100	5,886.100	77.875	80.260	80.260	0.000	0.000	0.000	5,805.840
01/08/2016	31/08/2016	5,354.125	5,211.600	5,211.600	58.625	60.460	60.460	0.002	0.002	0.002	5,151.138
01/09/2016	30/09/2016	5,069.750	4,984.900	4,984.900	65.625	66.790	66.790	1.080	1.080	1.080	4,917.030
01/10/2016	31/10/2016	7,261.625	7,120.680	7,120.680	28.875	29.830	29.830	0.000	0.000	0.000	7,090.850
01/11/2016	30/11/2016	13,639.500	13,318.000	13,318.000	10.500	11.220	11.220	0.010	0.010	0.010	13,306.770
01/12/2016	31/12/2016	11,596.375	11,343.390	11,343.390	50.750	51.610	51.610	0.016	0.016	0.016	11,291.764
Subtotal 2016		-	-	106,476.070	-	-	553.880	-	-	1.192	105,920.998
01/01/2017	31/01/2017	6,032.250	5,921.300	5,921.300	49.000	50.420	50.420	0.016	0.016	0.016	5,870.864
01/02/2017	28/02/2017	16,857.750	16,344.740	16,344.740	39.375	40.520	40.520	0.024	0.024	0.024	16,304.196
01/03/2017	31/03/2017	10,374.875	10,193.270	10,193.270	33.250	34.060	34.060	0.016	0.016	0.016	10,159.194
01/04/2017	30/04/2017	9,945.250	9,738.700	9,738.700	19.250	19.400	19.400	0.018	0.018	0.018	9,719.282
01/05/2017	31/05/2017	10,351.250	10,092.910	10,092.910	30.625	31.420	31.420	0.004	0.004	0.004	10,061.486
01/06/2017	30/06/2017	6,991.250	6,778.900	6,778.900	57.750	59.530	59.530	0.002	0.002	0.002	6,719.368
01/07/2017	31/07/2017	4,242.000	4,166.270	4,166.270	84.875	87.780	87.780	0.000	0.000	0.000	4,078.490
01/08/2017	31/08/2017	5,722.500	5,626.410	5,626.410	58.625	60.060	60.060	0.000	0.000	0.000	5,566.350
01/09/2017	30/09/2017	4,160.625	4,055.840	4,055.840	44.625	46.200	46.200	1.250	1.250	1.250	4,008.390
01/10/2017	31/10/2017	7,885.500	7,719.170	7,719.170	38.500	39.200	39.200	0.002	0.002	0.002	7,679.968
01/11/2017	30/11/2017	12,892.250	12,612.690	12,612.690	22.750	23.360	23.360	0.004	0.004	0.004	12,589.326
01/12/2017	31/12/2017	11,652.375	11,434.650	11,434.650	37.625	38.810	38.810	0.014	0.014	0.014	11,395.826
Subtotal 2017		-	-	104,684.850	-	-	530.760	-	-	1.350	104,152.740
01/01/2018	31/01/2018	10,951.500	10,727.270	10,727.270	18.375	19.010	19.010	0.018	0.018	0.018	10,708.242

Subtotal 2018	-	-	10,727.270	-	-	19.010	-	-	0.018	10,708.242
Total	-	-	406,167.590	-	-	2,173.630	-	-	6.490	403,987.470

5.2 Project Emissions

As per the methodology and the registered CDM-PDD, the project emission is 0.

5.3 Leakage

As per the methodology and the registered CDM-PDD, the leakage is 0.

5.4 Net GHG Emission Reductions and Removals

Year	Baseline emissions or removals (tCO ₂ e)	Project emissions or removals (tCO ₂ e)	Leakage emissions (tCO ₂ e)	Net GHG emission reductions or removals (tCO ₂ e)
2014 (01/02/2014 to 31/12/2014)	73,238	0	0	73,238
2015 (01/01/2015 to 31/12/2015)	90,891	0	0	90,891
2016 (01/01/2016 to 31/12/2016)	94,891	0	0	94,891
2017 (01/01/2017 to 31/12/2017)	93,307	0	0	93,307
2018 (01/01/2018 to 31/01/2018)	9,593	0	0	9,593
Total	361,920	0	0	361,920

Comparison of the actual emission reductions with the estimated values of this monitoring period is analysed as follows:

Annual estimated emission reductions are 89,823 tCO₂e

Total days during this monitoring period are 1,461 days

Calculated estimation of the emission reductions: $89,823 * 1,461 / 365 = 359,538$ tCO₂e

The actual emission reductions achieved during this monitoring period are 0.66% higher than the estimated ex-ante amount, which slightly fluctuates around the ex-ante amount.