

GUOHUA RONGCHENG PHASE III WIND FARM PROJECT

Document Prepared By Beijing Cronus Technology Consultancy Centre

Tel: +86 10 62258766

| | |
|--------------------------|--|
| Project Title | Guohua Rongcheng Phase II Wind Farm Project |
| Version | 2.0 |
| Report ID | N/A |
| Date of Issue | 06/05/2014 |
| Project ID | PL1304 |
| Monitoring Period | 17/10/2010 - 18/07/2012 (first and last days included) |
| Prepared By | Ms. Trace Wang, Beijing Cronus Technology Consultancy Centre. |
| Contact | Beijing Cronus Technology Consultancy Centre Telephone: +86 10 62258766 |

Table of Contents

1 Project Details 3

1.1 Summary Description of the Implementation Status of the Project 3

1.2 Sectoral Scope and Project Type 4

1.3 Project Proponent 4

1.4 Other Entities Involved in the Project..... 4

1.5 Project Start Date..... 4

1.6 Project Crediting Period 5

1.7 Project Location 5

1.8 Title and Reference of Methodology 6

1.9 Other Programs 6

2 Implementation Status..... 7

2.1 Implementation Status of the Project Activity 7

2.2 Deviations 7

2.2.1 Methodology Deviations 7

2.2.2 Project Description Deviations 7

2.3 Grouped Project..... 7

3 Data and Parameters 7

3.1 Data and Parameters Available at Validation 7

3.2 Data and Parameters Monitored..... 8

3.3 Monitoring Plan 11

3.3.1 Monitoring parameter 11

3.3.2 Monitoring system installation 11

3.3.3 Monitoring structure..... 12

3.3.4 Meters maintenance and calibration 12

3.3.5 Emergency procedures 12

4 Quantification of GHG Emission Reductions and Removals 12

4.1 Baseline Emissions 13

4.2 Project Emissions 15

4.3 Leakage 15

4.4 Net GHG Emission Reductions and Removals 15

1 PROJECT DETAILS

1.1 Summary Description of the Implementation Status of the Project

Guohua Rongcheng Phase III Wind Farm Project (hereinafter referred to as the Project) is located in Chengshan Town, Rongcheng City, Shandong Province, People’s Republic of China. The project is invested and implemented by Guohua Resourceful (Rongcheng) Wind Power Generation Co., Ltd.

The Project has a total installed capacity of 49.5 MW, consisting of 33 wind turbines with unit capacity of 1500kW. The expected annual power delivered to the grid is 100,263 MWh. The power output is delivered to the North China Power Grid (NCPG) which is dominated by fossil-fuel fired power via Shandong Power Grid. The expected annual emission reduction of the project is 89,823t CO₂e.

The key technical parameters of the project are summarized in the following table.

| | |
|---------------------|---|
| Manufacturer | Xinjiang Goldwind Science and Technology Co., Ltd. |
| Model | GW82/1500 |
| 1. Rotor | |
| Diameter | 82 m |
| Amount of vane | 3 |
| Height of hub | 70m |
| Cut-in wind speed | 3.0 m/s |
| Cut-out wind speed | 22.0 m/s |
| 2. Generator | |
| Rated Power | 1,580kW |
| Rated voltage | 690V |

The Project started construction on 15/12/2010. The first power unit started operation on 17/10/2010, and the last power unit started operation on 19/12/2010.

The Project has been registered as a CDM project on 19/07/2012 with the CDM registration reference number 6580.

The monitoring period starts from 17/10/2010 and ends to 18/07/2012. In this monitoring period, the total achieved emission reduction is 152,804 tCO₂e.

1.2 Sectoral Scope and Project Type

Sectoral scope: Scope 1

Project type: Type I (Renewable energy projects)

The project is not a grouped project.

1.3 Project Proponent

| | |
|-------------------|--|
| Organization name | Guohua Resourceful (Rongcheng) Wind Power Generation Co., Ltd. |
| Contact person | Xuepei Feng |
| Title | Manager |
| Address | No.3 South Road of Dongzhimen, Dongcheng District, Beijing People's Republic of China |
| Telephone | +86 010-58157576 |
| Email | fengxuepei@guohua.com.cn |

1.4 Other Entities Involved in the Project

| | |
|---------------------|---|
| Organization name | DEMETER VENTURE UK LIMITED |
| Role in the project | VER buyer |
| Contact person | Tao Xue |
| Title | CEO |
| Address | CHASE BUSINESS CENTRE-CHD 39 - 41 CHASE SIDE LONDON N14 5BP |
| Telephone | +86 10 62258766 |
| Email | taorholland@gmail.com |

1.5 Project Start Date

The project start date is 17/10/2010.

1.6 Project Crediting Period

The Project was put into operation on 17/10/2010, and registered as a CDM project on 19/07/2012. Therefore, the Project Crediting Period is from 17/10/2010 to 18/07/2012, covering one year and 298 days.

1.7 Project Location

The proposed project is located in Chengshan Town, Rongcheng City, Shandong Province, People's Republic of China. The coordinates of the proposed project location area are 121°11' - 122°42' east longitude and 36°41' - 37°35' north latitude.

The geographic location of the Project is shown in Figure-1 below.

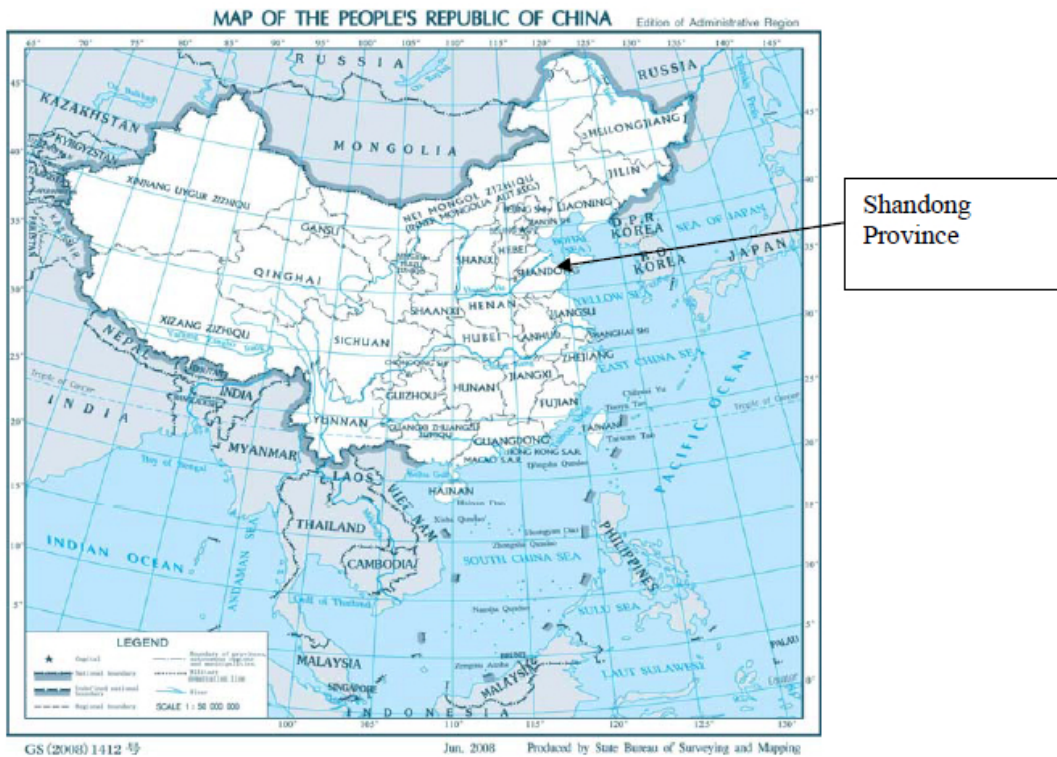



Figure 1 The geographic location of the project

1.8 Title and Reference of Methodology

The CDM consolidated baseline and monitoring methodology:

ACM0002 (Version 12.3.0): "Consolidated baseline methodology for grid-connected electricity generation from renewable sources"

<http://cdm.unfccc.int/methodologies/PAMethodologies/approved.html>

1.9 Other Programs

The project has been registered as a CDM project on 19/07/2012, for which a renewable crediting period of 3×7 years will be used under the CDM GHG Program. Therefore, CO₂ emission reductions generated by the project during the CDM crediting period will be verified as unique CERs, but not VCUs to avoid double counting. As to the project under VCS (Version.3.4), only emission reductions achieved from 17/10/2010 to 18/07/2012 will be considered as VCUs.

The project participants choose a clear VCS crediting period from 17/10/2010 to 18/07/2012, which has not created another form of environmental credits.

The project has been registered as a CDM project on 19/07/2012, and the registration number is 6580.

2 IMPLEMENTATION STATUS

2.1 Implementation Status of the Project Activity

The Project started construction on 26/04/2010. The first power unit started operation on 17/10/2010, and the last power unit started operation on 19/12/2010. The Project has an installed capacity of 49.5MW (33*1.5MW), providing an estimated annual net generation of about 100,263MWh. The voltage is raised to 110kV through the step-up substation, and the power is fed into the Shandong Grid, which is an integral part of the North China Power Grid. During the monitoring period from 17/10/2010 to 18/07/2012, all equipment worked well and no error or accident ever occurred.

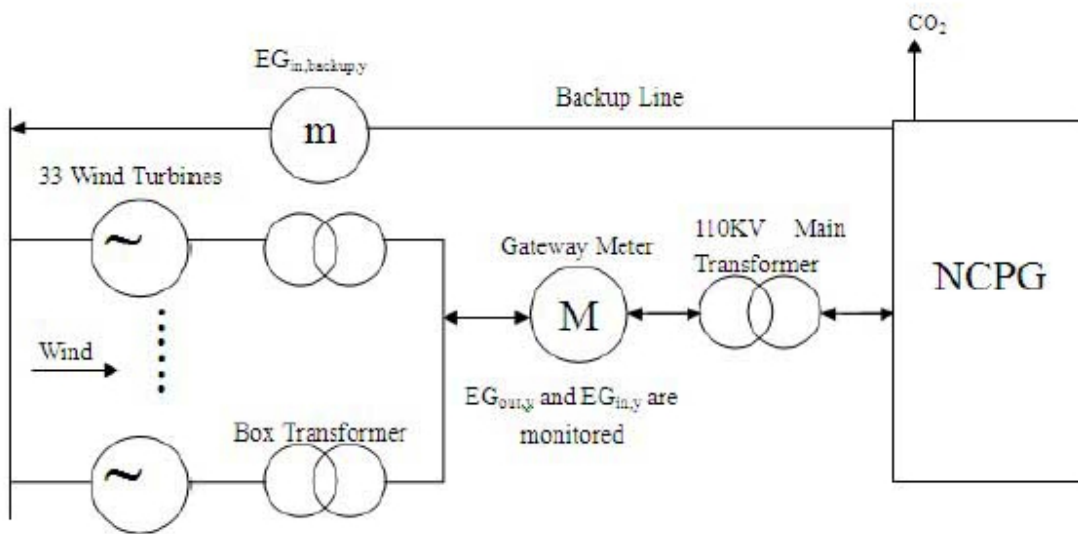

Figure 2 Diagram of the project

2.2 Deviations

2.2.1 Methodology Deviations

N/A

2.2.2 Project Description Deviations

N/A

2.3 Grouped Project

N/A

3 DATA AND PARAMETERS

3.1 Data and Parameters Available at Validation

| | |
|--|--|
| Data / Parameter | $EF_{grid,CM,y}$ |
| Data unit | tCO ₂ /MWh |
| Description | Emission Factor The combined margin emission factor of NCPG |
| Source of data | The registered PDD of the project |
| Value applied: | 0.895875 |
| Justification of choice of data or description of measurement methods and procedures applied | Official and authoritative statistics |
| Purpose of the data | Calculation of baseline emission |
| Comments | Na |

3.2 Data and Parameters Monitored

| | |
|---|--|
| Data / Parameter | $EG_{facility, y}$ |
| Data unit | MWh/yr |
| Description | Quantity of net electricity generation supplied by the project plant/unit to the grid in year y. |
| Source of data | Calculated based on the data of $EG_{out, y}$, $EG_{in, y}$ and $EG_{backup, y}$ |
| Description of measurement methods and procedures to be applied | $EG_{facility, y}$ equals to electricity delivered to the NCPG by the proposed project in year y ($EG_{out, y}$) minus the electricity consumed by the proposed project which is imported from the NCPG through the main line ($EG_{in, y}$) and the electricity consumed by the proposed project which is imported from the NCPG through the backup line ($EG_{backup, y}$). The data will be measured continuously, recorded monthly |
| Frequency of monitoring/recording | Monitoring continuously and recording monthly |
| Value monitored: | 170,566.902 MWh |
| Monitoring equipment | Monitored by bidirectional electricity meter (electronic) Serial number: 10030265270082 (M1) Accuracy: 0.5 Calibration frequency: At least once every three years Date of calibration: 03/06/2010, 02/06/2011 Validity: 01/06/2012 Calibration Entity: Wei Hai Power Supply Company |
| QA/QC procedures to be applied | The data of $EG_{out, y}$, $EG_{in, y}$ and $EG_{backup, y}$ will be double checked by receipt of sales or relevant commercial data. |
| Purpose of the data | Calculation of baseline emission |
| Calculation method | $EG_{facility, y} = EG_{out, y} - EG_{in, y} - EG_{backup, y}$ |
| Comments | - |

| | |
|---|--|
| Data / Parameter | $EG_{out\ y}$ |
| Data unit | MWh/yr |
| Description | Electricity generation supplied to the NCPG by the proposed project in year y. |
| Source of data | Measured by electricity meter on the project site. |
| Description of measurement methods and procedures to be applied | The electricity delivered to NCPG by the proposed project in the year y will be monitored and measured by meter installed in the project site. The readings of electricity meter will be continuously measured and monthly recorded. |
| Frequency of monitoring/recording | Monitoring continuously and recording monthly |
| Value monitored: | 171,337.777 MWh |
| Monitoring equipment | Monitored by bidirectional electricity meter (electronic) Serial number: 10030265270082(M1) Accuracy: 0.5 Calibration frequency: At least once every three years Date of calibration: 03/06/2010, 02/06/2011 Validity: 01/06/2012 Calibration Entity: Wei Hai Power Supply Company |
| QA/QC procedures to be applied | The meters are calibrated by qualified third party according to the relevant regulations. The accuracy of electricity meter is 0.5. |
| Purpose of the data | Calculation of baseline emission |
| Calculation method | - |
| Comments | - |

| | |
|---|--|
| Data / Parameter | $EG_{in\ y}$ |
| Data unit | MWh/yr |
| Description | Electricity consumed by the proposed project which is imported from the NCPG through the main line in the year y. |
| Source of data | Measured by electricity meter on the project site. |
| Description of measurement methods and procedures to be applied | The electricity consumed by the proposed project which is imported from the NCPG at the main line in the year y will be monitored and measured by meter installed in the project site. The readings of electricity meter will be continuously measured and monthly recorded. |
| Frequency of monitoring/recording | Monitoring continuously and recording monthly |

| | |
|--------------------------------|---|
| Value monitored: | 770.875 MWh |
| Monitoring equipment | Monitored by bidirectional electricity meter (electronic) Serial number: 10030265270082 (M1) Accuracy: 0.5 Calibration frequency: At least once every three years Date of calibration: 03/06/2010, 02/06/2011 Validity: 01/06/2012 Calibration Entity: Wei Hai Power Supply Company |
| QA/QC procedures to be applied | The meters are calibrated by qualified third party according to the relevant regulations. The accuracy of electricity meter is 0.5. |
| Purpose of the data | Calculation of baseline emission |
| Calculation method | - |
| Comments | Uncertainty level of data is low. |

| | |
|---|--|
| Data / Parameter | $EG_{backup,y}$ |
| Data unit | MWh/yr |
| Description | The electricity consumed by the proposed project which is imported from the backup line. |
| Source of data | Measured by electricity meter on the project site. |
| Description of measurement methods and procedures to be applied | The electricity consumed by the proposed project which is imported from the NCPG at the backup line in the year y will be monitored and measured by meter installed in the project site. The readings of electricity meter will be continuously measured and monthly recorded. |
| Frequency of monitoring/recording | Monitoring continuously and recording monthly |
| Value monitored: | 0 MWh |
| Monitoring equipment | Monitored by bidirectional electricity meter (electronic) Serial number: 10030265270067(M2) Accuracy: 0.5 Calibration frequency: At least once every three years Date of calibration: 03/06/2010, 02/06/2011 Validity: 01/06/2012 Calibration Entity: Wei Hai Power Supply Company |
| QA/QC procedures to be applied | The meters are calibrated by qualified third party according to the relevant regulations. The accuracy of electricity meter is 0.5. |
| Purpose of the data | Calculation of baseline emission |
| Calculation method | - |
| Comments | Uncertainty level of data is low. |

3.3 Monitoring Plan

3.3.1 Monitoring parameter

Baseline emission factor of the project is determined ex ante. Therefore the net electricity delivered by the Project to the North China Power Grid ($EG_{\text{facility}, y}$) is defined as the key data to be monitored. $EG_{\text{facility}, y}$ is calculated as follow:

$$EG_{\text{facility}, y} = EG_{\text{out}, y} - EG_{\text{in}, y} - EG_{\text{backup}, y}$$

A bi-directional gateway meter was installed on project site for monitoring the electricity delivered to the grid ($EG_{\text{out}, y}$) and the electricity consumed through the main line ($EG_{\text{in}, y}$). The accuracy of the meters is 0.5

A backup-line meter with the accuracy of 1.0 was installed to measure the electricity imported through the backup line. Electricity meters will be installed in accordance with *Technical Administrative Code of Electric Energy Metering (DL/T448-2000)*.

Data measured by two meters were monthly recorded by the project owner. On monthly basis, the grid company issues sales receipts/records to the project company, Sale receipts are used for double check the measured data from two meters. All meters mentioned above were continuously measured and monthly recorded used to calculate the Project’s net electricity delivered to the grid.

3.3.2 .Monitoring system installation

The flow chart and monitoring locations of the project is as followed:

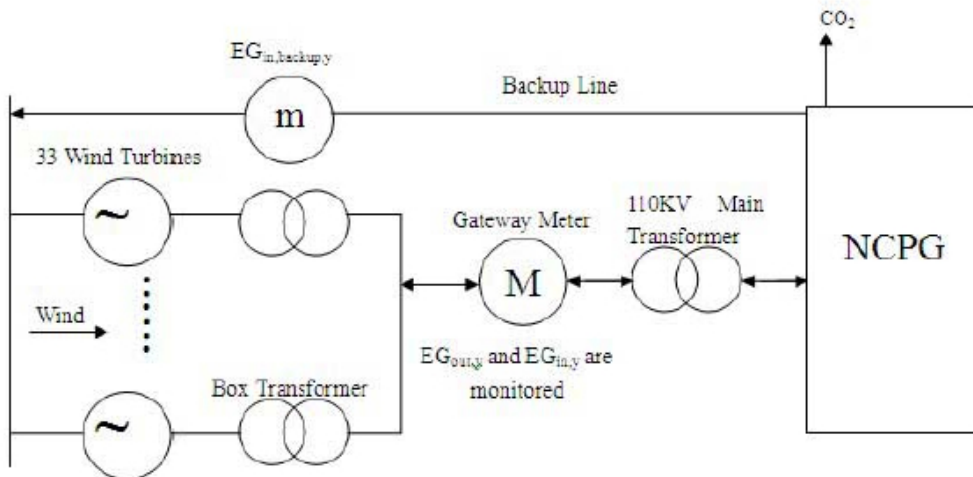

Figure 3 The flow chart and monitoring location of the project

3.3.3 Monitoring structure

The monitoring of the emission reductions will be carried out according to Figure below:

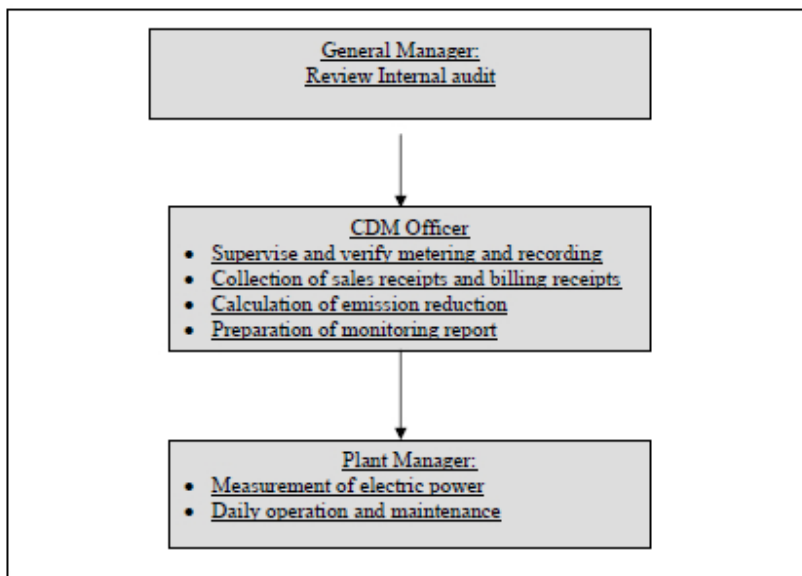

Figure 4 Organization chart

Roles and responsibilities of personnel

Plant manager of wind farm will collect the information and data required by the Monitoring Plan. The collected information will be documented and sent to the CDM officer monthly. The CDM officer will be in charge of the implementation of the Monitoring Plan and report to the General Manager of the company. The General Manager of the company will make the confirmations on monitoring calculation data and reports.

The project owner trained relevant staffs of the wind power plant for data monitoring and data management.

The training contains CDM knowledge, operational regulations, quality control (QC) standard, data monitoring and data management.

3.3.4 Meters maintenance and calibration

The periodical calibration and maintenance of the meters comply with the related standards and regulations of national power sector, so as to ensure the precision of meters. The meters have been calibrated annually and the calibration records shown that the accuracy of the meters during the monitoring period is in line with the approved monitoring plan.

3.3.5 Emergency procedures

After the occurrence of the conditions below, the meters shall be tested by the designated institute commissioned by the project owner and the power grid company together:

- a. the error of the meter is out of the permissible limits
- b. maintenance of the meters due to the faults of the meters' components

Once the above conditions occur, the line loss and the net electricity sent to the grid will be estimated by the project owner and the power grid company; otherwise, a conservative and reasonable methods agreed by both parties will be adopted.

3.4 Baseline Emissions

According to the registered CDM-PDD, the baseline emissions of the project are calculated as follows:

$$BE_y = EG_{\text{facility},y} \times EF_{\text{grid,CM},y} = (EG_{\text{out},y} - EG_{\text{in},y} - EG_{\text{backup},y}) \times EF_{\text{grid,CM},y} \quad (1)$$

Where:

- $EG_{\text{facility},y}$ = The net electricity supplied by the project activity to the grid(MWh);
- $EG_{\text{out},y}$ = Electricity delivered to NCPG by the proposed project (MWh);
- $EG_{\text{in},y}$ = Electricity consumed by the proposed project which is imported from the NCPG at the main line (MWh);
- $EG_{\text{backup},y}$ = Electricity consumed by the proposed project which is imported from the NCPG at the backup line (MWh);
- $EF_{\text{grid,CM},y}$ = Combined margin CO₂ emission factor for grid connected power generation in year *y* (tCO₂/MWh);

The electricity data from 17/10/2010 to 18/07/2012 are as follows:

| Period | Electricity delivered to NCPG by the project (MWh) ($EG_{\text{out},y}$) | | |
|-------------------------|---|----------------|--------------------|
| | Sales receipts | Meter readings | Conservative value |
| 17/10/2010 – 24/10/2010 | 465.213 | 531.125 | 465.213 |
| 25/10/2010 – 24/11/2010 | 943.000 | 1,049.125 | 943.000 |
| 25/11/2010 – 24/12/2010 | 6,149.453 | 6,227.375 | 6,149.453 |
| 2010-Total | / | / | 7,557.666 |
| 25/12/2010 – 24/01/2011 | 13,116.176 | 13,279.000 | 13,116.176 |
| 25/01/2011 – 24/02/2011 | 7,945.825 | 8,037.750 | 7,945.825 |
| 25/02/2011 – 24/03/2011 | 12,106.536 | 12,166.000 | 12,106.536 |
| 25/03/2011 – 24/04/2011 | 12,141.141 | 12,212.375 | 12,141.141 |
| 25/04/2011 – 24/05/2011 | 10,702.819 | 10,822.875 | 10,702.819 |
| 25/05/2011 – 24/06/2011 | 4,925.000 | 5,058.375 | 4,925.000 |
| 25/06/2011 – 24/07/2011 | 4,064.392 | 4,123.875 | 4,064.392 |
| 25/07/2011 – 24/08/2011 | 4,284.780 | 4,361.000 | 4,284.780 |
| 25/08/2011 – 24/09/2011 | 7,791.400 | 7,807.625 | 7,791.400 |
| 25/09/2011 – 24/10/2011 | 5,309.950 | 5,372.500 | 5,309.950 |

| | | | |
|-------------------------|---|----------------|--------------------|
| 25/10/2011 – 24/11/2011 | 7,432.820 | 7,742.000 | 7,432.820 |
| 25/11/2011 – 24/12/2011 | 11,835.242 | 12,419.750 | 11,835.242 |
| 2011-Total | / | / | 101,656.081 |
| 25/12/2011 – 24/01/2012 | 8,126.670 | 8,402.625 | 8,126.670 |
| 25/01/2012 – 24/02/2012 | 10,334.000 | 10,526.250 | 10,334.000 |
| 25/02/2012 – 24/03/2012 | 12,286.960 | 12,530.875 | 12,286.960 |
| 25/03/2012 – 24/04/2012 | 11,582.700 | 12,070.625 | 11,582.700 |
| 25/04/2012 – 24/05/2012 | 9,559.400 | 10,014.375 | 9,559.400 |
| 25/05/2012 – 24/06/2012 | 3,947.800 | 4,728.500 | 3,947.800 |
| 25/06/2012 – 18/07/2012 | 6,286.500 | 6,487.250 | 6,286.500 |
| 2012-Total | | | 62,124.030 |
| Total | | | 171,337.777 |
| Period | Electricity consumed by the proposed project which is imported from the NCPG at the main line (EG_{inv}) | | |
| | Sales receipts | Meter readings | Conservative value |
| 17/10/2010 – 24/10/2010 | 2.625 | 2.625 | 2.625 |
| 25/10/2010 – 24/11/2010 | 3.500 | 3.500 | 3.500 |
| 25/11/2010 – 24/12/2010 | 18.375 | 18.375 | 18.375 |
| 2010-Total | / | / | 24.500 |
| 25/12/2010 – 24/01/2011 | 7.000 | 7.000 | 7.000 |
| 25/01/2011 – 24/02/2011 | 51.625 | 51.625 | 51.625 |
| 25/02/2011 – 24/03/2011 | 11.375 | 11.375 | 11.375 |
| 25/03/2011 – 24/04/2011 | 13.125 | 13.125 | 13.125 |
| 25/04/2011 – 24/05/2011 | 30.625 | 30.625 | 30.625 |
| 25/05/2011 – 24/06/2011 | 40.250 | 40.250 | 40.250 |
| 25/06/2011 – 24/07/2011 | 29.750 | 29.750 | 29.750 |
| 25/07/2011 – 24/08/2011 | 63.000 | 63.000 | 63.000 |
| 25/08/2011 – 24/09/2011 | 40.250 | 40.250 | 40.250 |
| 25/09/2011 – 24/10/2011 | 41.125 | 41.125 | 41.125 |
| 25/10/2011 – 24/11/2011 | 62.125 | 62.125 | 62.125 |
| 25/11/2011 – 24/12/2011 | 42.000 | 42.000 | 42.000 |
| 2011-Total | / | / | 432.250 |
| 25/12/2011 – 24/01/2012 | 126.875 | 126.875 | 126.875 |
| 25/01/2012 – 24/02/2012 | 42.000 | 42.000 | 42.000 |
| 25/02/2012 – 24/03/2012 | 29.750 | 29.750 | 29.750 |
| 25/03/2012 – 24/04/2012 | 22.750 | 22.750 | 22.750 |
| 25/04/2012 – 24/05/2012 | 30.625 | 30.625 | 30.625 |
| 25/05/2012 – 24/06/2012 | 23.625 | 23.625 | 23.625 |
| 25/06/2012 – 18/07/2012 | 38.500 | 38.500 | 38.500 |
| 2012-Total | / | / | 314.125 |
| Total | / | / | 770.875 |
| Period | Electricity consumed by the proposed project which is imported from the NCPG at the backup line (EG_{backup}) | | |
| | Sales receipts | Meter readings | Conservative value |
| 17/10/2010 – 24/10/2010 | 0 | 0 | 0 |
| 25/10/2010 – 24/11/2010 | 0 | 0 | 0 |
| 25/11/2010 – 24/12/2010 | 0 | 0 | 0 |

| | | | |
|---------------------------------------|---|---|-------------|
| 2010-Total | / | / | 0 |
| 25/12/2010 – 24/01/2011 | 0 | 0 | 0 |
| 25/01/2011 – 24/02/2011 | 0 | 0 | 0 |
| 25/02/2011 – 24/03/2011 | 0 | 0 | 0 |
| 25/03/2011 – 24/04/2011 | 0 | 0 | 0 |
| 25/04/2011 – 24/05/2011 | 0 | 0 | 0 |
| 25/05/2011 – 24/06/2011 | 0 | 0 | 0 |
| 25/06/2011 – 24/07/2011 | 0 | 0 | 0 |
| 25/07/2011 – 24/08/2011 | 0 | 0 | 0 |
| 25/08/2011 – 24/09/2011 | 0 | 0 | 0 |
| 25/09/2011 – 24/10/2011 | 0 | 0 | 0 |
| 25/10/2011 – 24/11/2011 | 0 | 0 | 0 |
| 25/11/2011 – 24/12/2011 | 0 | 0 | 0 |
| 2011-Total | / | / | 0 |
| 25/12/2011 – 24/01/2012 | 0 | 0 | 0 |
| 25/01/2012 – 24/02/2012 | 0 | 0 | 0 |
| 25/02/2012 – 24/03/2012 | 0 | 0 | 0 |
| 25/03/2012 – 24/04/2012 | 0 | 0 | 0 |
| 25/04/2012 – 24/05/2012 | 0 | 0 | 0 |
| 25/05/2012 – 24/06/2012 | 0 | 0 | 0 |
| 25/06/2012 – 18/07/2012 | 0 | 0 | 0 |
| 2012-Total | / | / | 0 |
| Total | / | / | 0 |
| 2010 - EG_{facility,y} | / | / | 7,533.166 |
| 2011 - EG_{facility,y} | / | / | 101,223.831 |
| 2012 - EG_{facility,y} | / | / | 61,809.905 |
| EG_{facility,y} | / | / | 170,566.902 |

Therefore, the baseline emissions in 2010, 2011 and 2012 are calculated as follows:

$$BE_{y,2010} = 7,533.166 \times 0.895875 \text{ tCO}_2/\text{MWh} = 6,748 \text{ tCO}_2\text{e}$$

$$BE_{y,2011} = 101,223.831 \times 0.895875 \text{ tCO}_2/\text{MWh} = 90,683 \text{ tCO}_2\text{e}$$

$$BE_{y,2012} = 61,809.905 \times 0.895875 \text{ tCO}_2/\text{MWh} = 55,373 \text{ tCO}_2\text{e}$$

Thus, the total baseline emissions from 17/10/2010 to 19/07/2012 are 152,804 tCO₂e.

3.5 Project Emissions

The Project is a wind power project that the project emissions should not be considered as per ACM0002, i.e. $PE_y = 0 \text{ tCO}_2\text{e}$

3.6 Leakage

According to ACM0002, the leakage of the Project is considered as zero, i.e. $Ly = 0 \text{ tCO}_2\text{e}$.

3.7 Net GHG Emission Reductions and Removals

| Year | Baseline | Project emissions | Leakage | Net GHG emission |
|------|----------|-------------------|---------|------------------|
|------|----------|-------------------|---------|------------------|

| | emissions or removals (tCO ₂ e) | or removals (tCO ₂ e) | emissions (tCO ₂ e) | reductions or removals (tCO ₂ e) |
|--------------|--|----------------------------------|--------------------------------|---|
| Year 2010 | 6,748 | 0 | 0 | 6,748 |
| Year 2011 | 90,683 | 0 | 0 | 90,683 |
| Year 2012 | 55,373 | 0 | 0 | 55,373 |
| Total | 152,804 | 0 | 0 | 152,804 |