

HEBEI GUYUAN COUNTY DONGXINYING 199.5 MW WIND POWER PROJECT



Document Prepared By Hebei Construction Investment New Energy Co., Ltd.

Project Title	Hebei Guyuan County Dongxinying 199.5 MW Wind Power Project
Version	03
Date of Issue	24-July-2012
Prepared By	Guang Du
Contact	Address: Room 801, Yuyuan Plaza Tower A, No. 9 Yuhua West Road, Shijiazhuang, Hebei, P.R. China Telephone: +86-(0)311-8551 8612 E-mail: duguang_0915@163.com Website: www.suntien.com

Table of Contents

Part I The registered CDM PDD 1~56

Part II Further clarifications on requirements as per VCS Standard ver. 3.257~60

 1.2 Sectoral Scope and Project Type..... 57

 1.3 Project Proponent 57

 1.5 Project Start Date..... 57

 1.6 Project Crediting Period..... 57

 1.7 Project Scale and Estimated GHG Emission Reductions or Removals 57

 1.9 Project Location 58

 1.10 Conditions Prior to Project Initiation..... 59

 1.12 Ownership and Other Programs 59

 1.12.1 Proof of Title 59

 1.12.2 Emissions Trading Programs and Other Binding Limits..... 59

 1.12.3 Participation under Other GHG Programs 59

 1.12.4 Other Forms of Environmental Credit 60

 1.13 Additional Information Relevant to the Project 60



**CLEAN DEVELOPMENT MECHANISM
PROJECT DESIGN DOCUMENT FORM (CDM-PDD)
Version 03 - in effect as of: 28 July 2006**

CONTENTS

- A. General description of project activity
- B. Application of a baseline and monitoring methodology.
- C. Duration of the project activity / crediting period
- D. Environmental impacts
- E. Stakeholders' comments

Annexes

- Annex 1: Contact information on participants in the project activity
- Annex 2: Information regarding public funding
- Annex 3: Baseline information
- Annex 4: Monitoring plan

**SECTION A. General description of project activity****A.1 Title of the project activity:**

>>

Title: Hebei Guyuan County Dongxinying 199.5 MW Wind Power Project

PDD Version: 6.0

Date: 07/09/2011

A.2. Description of the project activity:

>>

Hebei Guyuan County Dongxinying 199.5 MW Wind Power Project (hereinafter referred to as the proposed project) is developed by Hebei Construction Investment New Energy Co., Ltd. It is located at the south of Guyuan County, Hebei Province, P.R.China. The proposed project will help reduce greenhouse gas (GHG) emissions generated from the high-growth, coal-dominated power generation in North China Power Grid (hereinafter referred to as NCPG). When the proposed project is operated, the electricity generated by the proposed project will displace part of the electricity from the NCPG, and thus greenhouse gas (GHG) generated by coal-fired power plants could be reduced.

The scenario existing prior to the start of the implementation of the proposed project: The location of the proposed project is covered by NCPG. Local electricity service is provided by the NCPG prior to the start of the implementation of the proposed project.

The project scenario: The proposed project is a newly constructed wind farm. The total capacity of the proposed project is 199.5 MW and a total of 133 wind turbines with 1,500 kW per-unit capacities were installed. The wind turbines will turn wind resource into clean electricity which will be exported to the NCPG. It won't produce CO₂ emission during the process. The expected annual electricity supplied to the NCPG is 405,685MWh and the estimated annual GHG emission reductions are 427,936 tCO₂e. The construction of the project began in August 2008, and the first turbine has been put into operation in June 2010. The electricity will replace the same amount of electricity generation by fossil fuel fired power plants connected into NCPG.

The baseline scenario: The baseline scenario is the same as the scenario existing prior to the start of the implementation of the proposed project.

The proposed project will not only supply renewable electricity to grid, but also contribute to sustainable development of the local community, the host country and the world by means of:

1. GHG emission reduction

The proposed project activity will achieve obvious GHG emission reductions by avoiding CO₂ emissions.

2. Pollutants emission reduction through replacing fossil fuel combustion

The proposed project is to replace electricity generated by grid-connected coal-fired power plants in the NCPG, and thus reduce fossil fuel consumption and avoid pollutants emission, such as sulfur dioxide and dust, brought by fossil fuel combustion. Therefore, the proposed project has obvious environmental benefit.

3. Employment opportunities

The conducting of the proposed project will create certain job opportunities for local people during operation, and achieve the economic growth in the region. Furthermore, the proposed project plans to utilize domestic made state-of-the-art wind turbines to promote the wind turbine manufacturing industries.

A.3. Project participants:



>>

Name of Party involved (*) (host) indicates a host Party)	Private and/or public entity (ies) project participants (*) (as applicable)	Kindly indicate if the Party involved wishes to be considered as project participant (Yes/No)
P.R.China (host)	Hebei Construction Investment New Energy Co., Ltd.	No
The United Kingdom of Great Britain and Northern Ireland	Shell Trading International Limited.(UK)	No
(*) In accordance with the CDM modalities and procedures, at the time of making the CDM-PDD public at the stage of validation, a Party involved may or may not have provided its <u>approval</u> . At the time of requesting registration, the approval by the Party (ies) involved is required.		
Note: When the PDD is filled in support of a proposed new methodology (form CDM-NM), at least the host Party (ies) and any known project participant (e.g. those proposing a new methodology) shall be identified.		

For detailed information, please refer to Annex I.

A.4. Technical description of the project activity:

A.4.1. Location of the project activity:

>>

A.4.1.1. Host Party(ies):

>>

People's Republic of China

A.4.1.2. Region/State/Province etc.:

>>

Hebei Province

A.4.1.3. City/Town/Community etc:

>>

Guyuan County, Zhangjiakou City

A.4.1.4. Detail of physical location, including information allowing the unique identification of this project activity (maximum one page):

>>

The project site is located in the south of Guyuan County, Zhangjiakou City of Hebei Province. It is about 20 km from Guyuan County. The exact geographical coordinates of the project are 115.2997°~115.7508°E, 41.3169°~41.5661°N. Figure 1 shows the location of the proposed project:

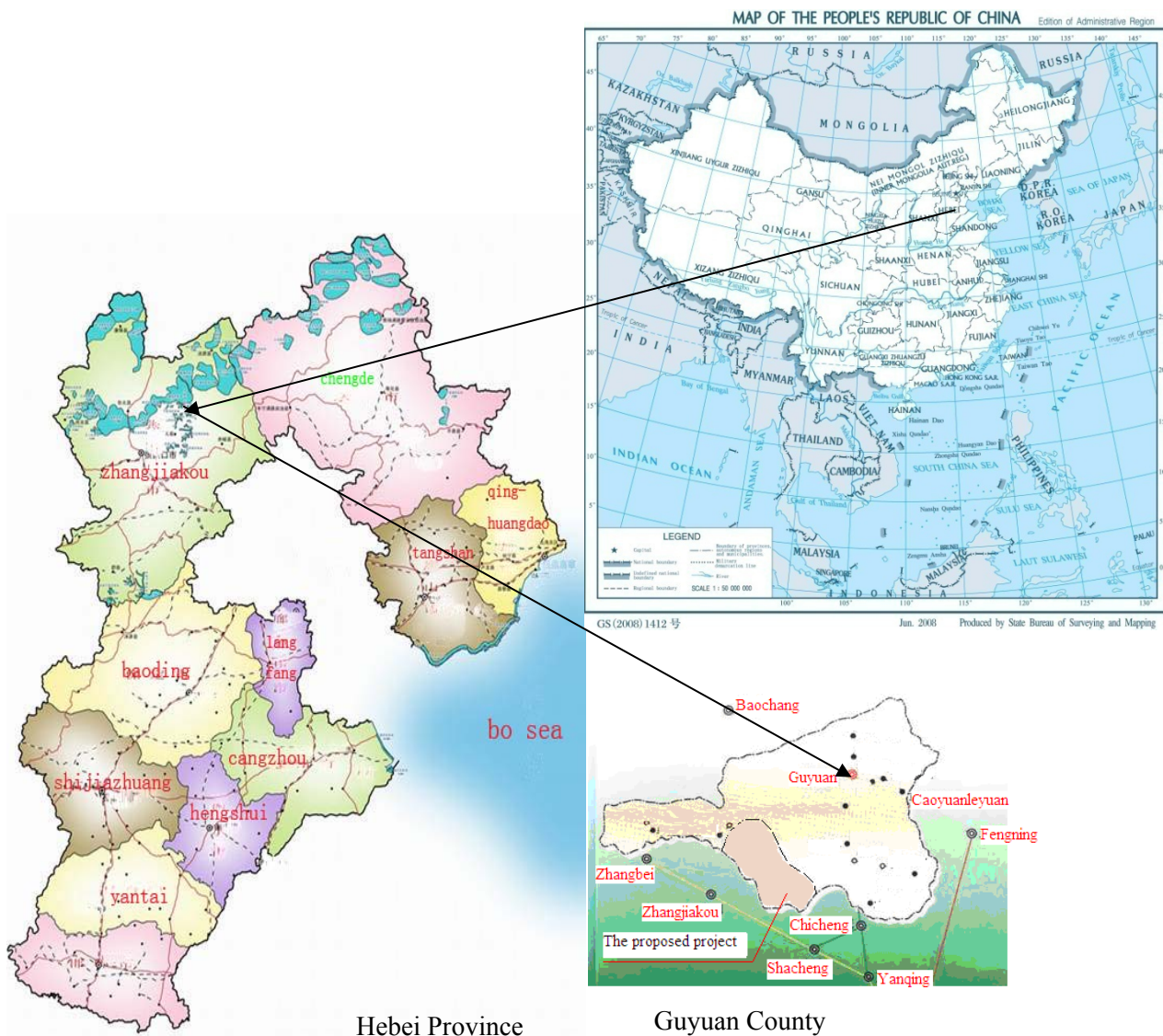

Figure 1. The location of the proposed project

A.4.2. Category(ies) of project activity:

>>
Sectoral scope 1: energy industries (renewable sources)

A.4.3. Technology to be employed by the project activity:

>>
The scenario existing prior to the start of the implementation of the proposed project: The location of the proposed project is covered by NCPG. Local electricity service is provided by the NCPG prior to the start of the implementation of the proposed project.

The project scenario: The proposed project is a newly constructed wind farm. The total capacity of the proposed project is 199.5 MW and a total of 133 wind turbines with 1,500 kW per-unit capacities were installed. The wind turbines will turn wind resource into clean electricity which will be exported to the NCPG. It won't produce CO₂ emission during the process. The expected annual electricity supplied to the NCPG is 405,685MWh and the estimated annual GHG emission reductions are 427,936 tCO₂e. The

construction of the project began in August 2008, and the first turbine has been put into operation in June 2010. The electricity will replace the same amount of electricity generation by fossil fuel fired power plants connected into NCPG and reduce the CO₂ emissions.

A total of 133 wind turbines of 1,500 kW (FD77B) will be supplied by Dongfang Steam Turbine Co., Ltd. On average, the project activity is expected to operate 2,034 hours per year, which corresponds to output power of 405,685 MWh to NCPG annually. The plant load factor (PLF) is 23.22% which is consistent with the officially approved FSR compiled by an independent engineering company with national first-level qualification certification. The main technical parameters are shown in the following table 1.

Table 1. The main technical parameters

Turbine type	FD77B
Rated Power (kW)	1,500
Cut-in Wind Speed (m/s)	3.0
Rotor Diameter (m)	77
Rated Wind Speed (m/s)	12
Tower Height (m)	61.5
Rated Voltage (V)	690
Generator Type	double-fed asynchronous motor

Data source: Technical specification of wind turbine purchase contract

Each turbine will have a 0.69/35 kV transformer. The electricity output will be transmitted by 35 kV transmission lines to 35kV/220 kV main transformer, and then to NCPG via Xiaochang Substation by 220 kV transmission lines. According to the Feasibility Study Report and the Environmental Impact Assessment Report of the proposed project, the technology employed by the proposed project has been used in China widely and is environmentally safe.

The simplified flow diagram and the meters that will be installed within the project activity are shown in the following figure 2:

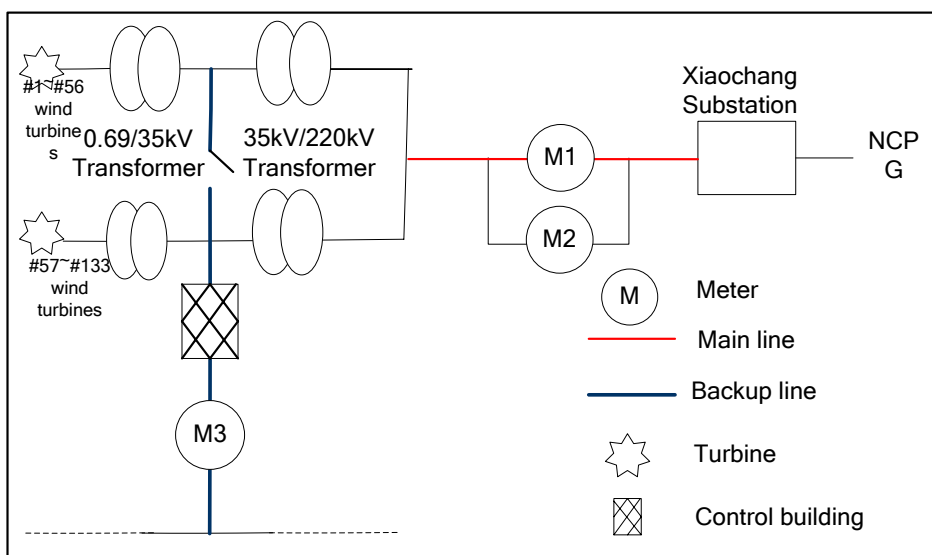

Figure 2. The simplified flow diagram of the proposed project

The baseline scenario: The baseline scenario is the NCPG which is the same as it existing prior to the start of the implementation of the proposed project.

There is no technology transferred from developed countries involved in this project activity.

**A.4.4. Estimated amount of emission reductions over the chosen crediting period:**

>>

The proposed project adopts renewable crediting period. Annual emission reductions of the proposed project are estimated to be 427,936 tCO₂e. For detailed calculation, please refer to section B. The total emission reductions of the project will be 2,995,552 tCO₂e during the first crediting period (01/12/2011-30/11/2018).

Years	Annual estimation of emission reductions in tonnes of CO ₂ e
01/12/2011-31/12/2011	35,661
2012	427,936
2013	427,936
2014	427,936
2015	427,936
2016	427,936
2017	427,936
01/01/2018-30/11/2018	392,275
Total estimated reductions (tonnes of CO₂e)	2,995,552
Total number of crediting years	7 × 3
Annual average over the crediting period of estimated reductions (tonnes of CO₂e)	427,936

A.4.5. Public funding of the project activity:

>>

No public funds from Annex I countries is involved in the proposed project.

SECTION B. Application of a baseline and monitoring methodology:**B.1. Title and reference of the approved baseline and monitoring methodology applied to the project activity:**

>>

The proposed project applies the approved consolidated baseline and monitoring methodology ACM0002 “Consolidated baseline methodology for grid-connected electricity generation from renewable sources” (Version 12.1.0).

The methodology also refers to the latest approved versions of the following tools:

- ◆ Tool to calculate the emission factor for an electricity system (Version 02);
- ◆ Tool for the demonstration and assessment of additionality (Version 05.2);
- ◆ Combined tool to identify the baseline scenario and demonstrate additionality (Version 02.2), (this tool is not applicable for this project);
- ◆ Tool to calculate project or leakage CO₂ emissions from fossil fuel combustion (Version 02), (this tool is not applicable for this project).

For more information regarding the methodology and the tools as well as their consideration by the Executive Board, please refer to <http://cdm.unfccc.int/methodologies/PAMethodologies/approved.html>

B.2. Justification of the choice of the methodology and why it is applicable to the project activity:

>>

Wind power generation technology is a renewable electricity generation technology which displaces



fossil fuel-fired power generation technology to supply electricity to the grid. Therefore the methodology used to determine the project baseline is the approved consolidated baseline methodology ACM0002. The methodology can be used to calculate GHG emission reductions achieved by wind power generation.

The methodology ACM0002 (Version 12.1.0) is applicable to the proposed project, because the proposed project meets all the applicability criteria stated in the methodology with relevance to wind power project:

- The proposed project is the installation of a new power plant at a site where no renewable power plant was operated prior to the implement of the project activity;
- The proposed project is the installation of a wind power plant;
- The proposed project does not involve switching from fossil fuels to renewable energy sources at the site of the project activity;

Therefore, the proposed project activity is in accordance with the applicability of methodology ACM0002 (Version 12.1.0).

In addition, the proposed project meets the applicability conditions included in the “Tool to calculate the emission factor for an electricity system” (Version 02).

- ◆ **This tool may be referred to in order to estimate the OM, BM and/or CM for the purpose of calculating baseline emissions for a project activity substitutes electricity from the grid, i.e. where a project activity supplies electricity to a grid.**

Furthermore, the proposed project meets the applicability conditions included in the “Tool for the demonstration and assessment of additionality” (Version 05.2).

- ◆ **This tool may be referred to in order to demonstrate the additionality of the proposed project.**

In the methodology ACM0002 “Consolidated Baseline and Monitoring Methodology for Grid-connected Electricity Generation from Renewable Sources” (Version 12.1.0), the baseline scenario has been given for a new grid-connected wind power plant. Therefore, “Combined tool to identify the baseline scenario and demonstrate additionality” (Version 02.2) is not applicable for this project.

The proposed project is a new grid-connected wind power plant which does not include the combustion of fossil fuels. Therefore, “Tool to calculate project or leakage CO₂ emissions from fossil fuel combustion” (Version 02) is not applicable for this project.

B.3. Description of the sources and gases included in the project boundary

>>

The electricity generated by the proposed project will be connected to the NCPG. The NCPG includes Beijing City, Tianjin City, Hebei Province, Shanxi Province, Shandong Province and Inner Mongolia.

According to the methodology ACM0002 (Version 12.1.0) and China DNA’s guidance¹, the spatial extent of the proposed project boundary includes the proposed project site and all the power plants connected physically to NCPG which the proposed project will be connected to. The simplified flow diagram is shown as follow:

¹ <http://cdm.ccchina.gov.cn/WebSite/CDM/UpFile/2008/20081230102527637.pdf>

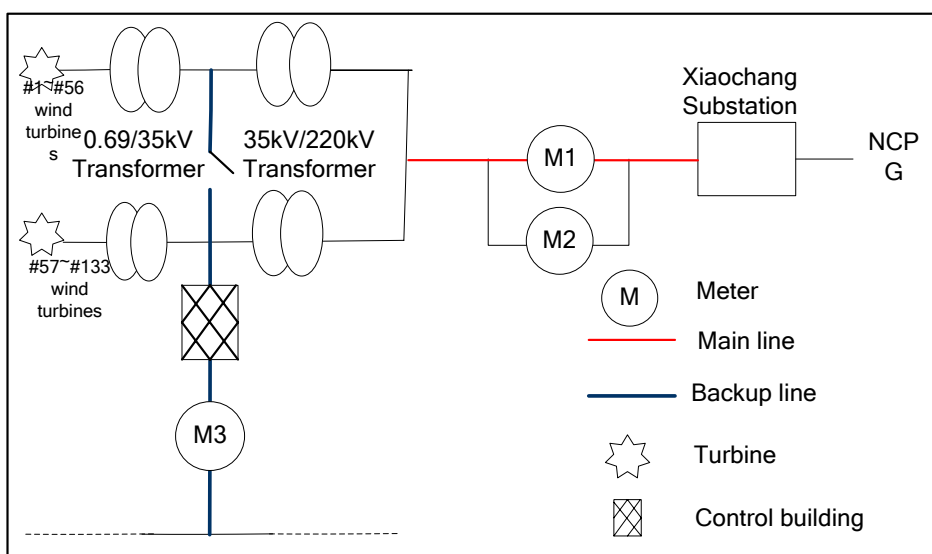

According to ACM0002 (Version 12.1.0), the project emission of the proposed project is zero. For the purpose of calculating project emissions and baseline emissions, the emission sources and gases which are included in the project boundary are listed in the following table.

	Source	Gas	Included?	Justification/Explanation
Baseline	Emissions from the fossil-fired power plants of NCPG	CO ₂	Yes	Main emission source
		CH ₄	No	According to ACM0002 (Version 12.1.0), this is excluded.
		N ₂ O	No	According to ACM0002 (Version 12.1.0), this is excluded.
Project Activity	Emissions caused by the proposed project activity	CO ₂	No	According to ACM0002 (Version 12.1.0), project emission is excluded as a wind power project.
		CH ₄	No	According to ACM0002 (Version 12.1.0), project emission is excluded as a wind power project.
		N ₂ O	No	According to ACM0002 (Version 12.1.0), project emission is excluded as a wind power project.

B.4. Description of how the baseline scenario is identified and description of the identified baseline scenario:

>>

The proposed project activity is the installation of a new grid-connected wind power plant, and it will be connected to NCPG. So according to ACM0002 “Consolidated baseline methodology for grid-connected electricity generation from renewable sources” (Version 12.1.0), the baseline scenario is the following:

Electricity delivered to the grid (NCPG) by the project activity would have otherwise been generated by the operation of grid-connected power plants and by the addition of new generation sources, as reflected in the combined margin (CM) calculations described in the section B.6.

In addition, the proposed project meets the applicability conditions included in the “Tool to calculate the emission factor for an electricity system” referred above:



- ◆ **This tool may be referred to in order to estimate the OM, BM and/or CM for the purpose of calculating baseline emissions for a project activity substitutes electricity from the grid, i.e. where a project activity supplies electricity to a grid.**

The proposed project will supply electricity to NCPG, and therefore can use this tool to estimate the OM, BM and CM for calculating baseline emissions.

According to ACM0002, baseline emissions are equal to the power generated by the project that is delivered to the NCPG, multiplied by the baseline emission factor. The baseline emission factor ($EF_{grid,CM,y}$) is calculated as a Combined Margin (CM), which consists of the weighted average of Operating Margin (OM) emission factor and Build Margin (BM) emission factor. The key parameters used for emission reductions calculation are as follow. For the detailed information, please see the Annex 3.

Parameter	Unit	Value
EF_{OM}	tCO ₂ e/MWh	1.1169
EF_{BM}	tCO ₂ e/MWh	0.8687
$EF_{grid,CM,y}$	tCO ₂ e/MWh	1.05485

B.5. Description of how the anthropogenic emissions of GHG by sources are reduced below those that would have occurred in the absence of the registered CDM project activity (assessment and demonstration of additionality):

>>

During the early planning stages of the proposed project, the project sponsor considered carbon finance and the CDM to ensure that the proposed project was financially viable.

The Feasibility Study Report (FSR) of the project considering the CDM revenue was completed in January 2008 by North China Power Engineering (Beijing) Co., Ltd. With reference to existing IRR benchmarks in the FSR, with the revenues of CERs, the project IRR of the proposed project activity is higher than the benchmark, while without the revenues of CERs, the IRR of the proposed project activity is lower than the benchmark. The proposed project is financially unacceptable because of its low profitability. With the financial analysis presented in FSR, the project sponsor started looking for a qualified CDM consulting company and a potential buyer. Consequently, a protracted series of negotiations commenced with a number of carbon buyers until the project sponsor finally managed to sign the Emission Reductions Purchase Agreement (ERPA) on the 4th March, 2008. The FSR of the project considering the CDM revenue was approved by National Development and Reform Committee on the 4th June, 2008.

Following the “guideline on the demonstration and assessment of prior consideration of the CDM” made in the EB 49 meeting, the project owner submitted the Notification Form about the proposed project to the Chinese DNA on 2nd Sep 2008 and has received the Notification Form issued by the Chinese DNA on 2nd Oct 2008.

Table 2 lists the timeline indicating the project implementation and the efforts tried for applying the project as a CDM activity.

Table2. Overview of key events in the development of the project

Date	Events
19/11/2007	Received the Environmental Impact Assessment Report Approval.
01/2008	Completed the FSR considering the CDM revenue.
from January 2008	Collected the stakeholders’ responses on the project.
04/03/2008	Signed the Emission Reduction Purchase Agreement.
04/06/2008	Received the Feasibility Study Report (FSR) Approval



17/08/2008	Signed the Construction Contract.
25/08/2008	Signed the Starting Construction Order.
29/08/2008	Signed the Purchase Agreements of the turbine and the generator.
02/09/2008	Submitted the Notification Form about the proposed project to the Chinese DNA.
02/10/2008	Received the Notification Form issued by Chinese DNA.
13/11/2008	The PDD of the proposed project was published on UNFCCC website.

According to these events, we can see that carbon finance was seriously considered in the decision to proceed with the proposed project activity. If the project can be registered as CDM project successfully, CDM revenue will eliminate the financial barrier while also meet the investors' expectations to ensure the continued development and operation of the project.

The additionality will be demonstrated by "Tool for the demonstration and assessment of additionality" (Version 05.2).

Step 1. Identification of alternatives to the project activity consistent with current laws and regulations.

Sub-step 1a. Define alternatives to the project activity.

- Alternative 1.* The proposed project not undertaken as a CDM project activity.
- Alternative 2.* Construction of a coal-fired power plant with the same annual electricity generation as the proposed project.
- Alternative 3.* Electricity delivered to NCPG by the project activity would have otherwise been generated by the operation of grid-connected power plants and by the addition of new generation sources.

Sub-step 1b. Enforcement of applicable laws and regulations.

Alternative 1 developing the proposed project not undertaken as a CDM project meets Chinese current regulations and laws.

Alternative 2 should be eliminated from the following consideration because it does not comply with the national regulation for controlling small scale thermal power plant. The average generation hours for fossil fuel fired power plants are 5,633² hours in 2006. To provide the same output as the proposed project, the alternative baseline scenario for the proposed project should be a grid-connected fossil fuel fired power plant with installed capacity of about 72.1 MW. However, according to the regulations from the National Development and Reform Commission in China³, thermal power plants with capacity below 135 MW are prohibited for construction within the grid connected area. Consequently, the *Alternative 2* is not a feasible alternative scenario;

Alternative 3 is in compliance with all mandatory laws and regulations in China and faced with no economical barriers, which the annual electricity output of NCPG has been increasing for many years (China Electric Power Yearbook 2005-2007). Hence, the *Alternative 3* is a credible and realistic alternative. As a result, providing the same electricity output by NCPG is selected as the baseline scenario for the proposed project.

In conclusion, the credible and realistic alternatives for power generation are *Alternative 1* and *Alternative 3*.

Step 2. Investment analysis.

Sub-step 2a. Determine appropriate analysis method.

² <China Electric Power Yearbook 2007>, P20

³ Notice on Strictly Prohibiting the Installation of Fuel-fired Generators with the Capacity of 135 MW or below issued by the General Office of the State Council, decree no. 2002-6.



According to “Tool for the demonstration and assessment of additionality” (Version 05.2), three options can be applied for the investment analysis: the simple cost analysis, the investment comparison analysis and the benchmark analysis.

The simple cost analysis (Option I) is not applicable for the proposed project because the project activity will generate economic benefits from electricity sale other than CERs income.

The investment comparison analysis (Option II) is also not applicable for the proposed project because the baseline scenario, providing the same capacity or electricity output by the NCPG, is not a new investment project.

To conclude, the benchmark analysis (Option III) will be used to identify whether the financial indicators (such as IRR or NPV) of the proposed project is better than relevant benchmark value.

Sub-step 2b. Apply benchmark analysis.

According to the *Interim Rules on Economic Assessment of Electrical Engineering Retrofit Projects*⁴ issued by State Power Corporation of China, the benchmark IRR (after tax) of power industry is 8% of the project IRR and it is widely used in wind power projects. The project is considered to be financially feasible when the project IRR is higher than or equal to the benchmark.

Sub-step 2c. Calculation and comparison of financial indicators.

Based on the Feasibility Study Report (FSR) of the proposed project, the basic parameters for calculation of financial indicators are shown in the following table:

Table 3. Main parameters for calculation of financial indicators

Items	Unit	Amount	Source
Installed capacity	MW	199.5	FSR
Estimated annually electricity output	MWh	405,685	FSR
Static total investment	Million RMB	1867.93	FSR
Average annual O&M cost	Million RMB	21.70	FSR
Electricity tariff (incl. VAT)	RMB/kWh	0.5006**	FSR
Value added tax rate		8.5%	FSR
Income tax rate		25%	FSR
Urban maintenance and construction tax		5%*	FSR
Surtax for education rate		3%	FSR
Depreciation rate		6.00%	FSR
Recovery of residue value of the fixed	Million RMB	95.81	FSR
Project life time	Year	22	FSR
CERs price to calculate project IRR	EUR/tCO ₂ e	12.5	ERPA

*Notes: The calculation of urban maintenance and construction tax and surtax for education are based on value-added tax multiplied by their rates separately.

**According to the FSR the tariff after 30,000h will use local thermal power tariff, lower than the approval tariff 0.5006 RMB/kWh (incl. VAT). During the life time of the proposed project, the same tariff of 0.5006 RMB/kWh (incl. VAT) was adopted in this PDD so it was conservative.

The clarification regarding the highest tariff issue in Hebei province

⁴ Issued by the Operation Department of Power Generation and Transmission, State Power Corporation, 10/09/2002



1. How the tariff was determined

All data and parameters used for the financial analysis, including the proposed tariff, in the PDD have been sourced from the FSR which was approved by National Development and Reform Commission on 4th June 2008.

The input values are valid and applicable at the time of the investment decision.

During the preparation of the FSR, the project participant received the official document for the tariff as the “The notification of Fa Gai Neng Yuan [2007]1283”. According to this notification, the proposed project should be given to the same tariff as the project “CECIC HKC Danjinghe Wind Farm Project”. The project “CECIC HKC Danjinghe Wind Farm Project” was approved by National Development and Reform Commission on 26th March 2007. In this notification, the tariff before 30,000 hours is 0.5006RMB/kWh including VAT, and the tariff after 30,000 hours should be the local average tariff of the thermal power plants.

The tariff was reconfirmed by the approval letter (fa gai neng yuan [2008] No, 1325) to complete the official procedure. But during the life time of the proposed project, the same tariff of 0.5006 RMB/kWh was adopted in this PDD and IRR spreadsheet so it was conservative.

2. The trend of the approved tariffs of all the wind farms in Hebei province

All the wind farm projects in Hebei and their tariffs are listed in Table 4 below.

Table 4 The actual approved electricity tariff of all wind farms in Hebei Province

No.	Time (wind turbine installed)	Project	Tariff (incl. VAT) Yuan/kWh	Reference	CDM status
Prior to the Power Sector Reform (March 2002)					
	1996-1998	Zhangbei Changcheng 9.85MW wind farm	0.65	Ji Jia Ge [3][2002]242 issued by NDRC in Feb 2002 ^{5*}	Early demonstration and ODA funded projects
	2001.11	Chengde Hongsong 3.6MW wind farm			
The Electric Power Sector Reform Programme (March 2002): Projects in Wind Resource Area II of Hebei (Chengde City and Zhangjiakou City)					
1	2005.11	Chengde Hongsong wind farm	0.6	Ji Jia Guan Zi [2006]57 issued by Price Bureau of Hebei province In Jun 2006 ⁶	VER
2	2005.7	Guohua Shangyi Manjing wind farm	0.6		VER
3	2006.11	Hebei Shangyi Manjing East Wind Farm	0.6		Ref No.0842 Registered
4	2006.5	Zhangbei Manjing Wind Farm	0.6		Ref No.0233 Registered
5	2006.12	Zhangbei Mijiagou 49.5 MW Wind Farm	0.6		Ref No.0845 Registered
6	2006.1	Hebei Kangbao Wolongtushan 30 MW Wind farm	0.6		Ref No.0878 Registered

5 <http://www.fjjg.gov.cn/fjwj/jgfw/gjjgzc/webinfo/2002/02/1187774415686122.htm>

6 http://www.hebj.gov.cn/upfiles/xy_col32super_20081210161322124272.htm. The tariff of 0.65 RMB/kWh for the Zhangbei Changcheng 9MW wind farm and the Chengde Hongsong 3.6MW wind farm, which were approved in Feb 2002, were also reconfirmed in this notification made in 2006.



7	2007.8	Guyuan 30.6MW Wind Farm	0.54	Fa Gai Jia Ge [2007]1260 issued by NDRC in Jun 2007	Ref No.0873 Registered
8	2005.11	Hebei Chengde Songshan Wind farm	0.54		Ref No.0877 Registered
9	2007.12	Hebei Chongli Qingsanying 49.3MW Wind Farm	0.54		Ref No.2140 Registered
10	after 2007.12.31	Hebei Shirensan Wind farm	0.54		Ref No.2067 Registered
11	after 2007.12.31	Hebei Wanquan Yulong Wind farm	0.54		Ref No.2205 Registered
12	after 2007.12.31	Hebei Yuxian Kongzhongcaoyuan 49.5MW Wind Farm Project	0.54		Ref No.2088 Registered
13	2007.10	Hebei Shangyi Manjing West Wind Farm	0.54	Fa Gai Jia Ge [2007]3303 issued by NDRC in Dec 2007	Ref No.2040 Registered
14	after 2007.12.31	Hebei Weichang Zhangjiawan Wind farm	0.54		Ref No.3093 Review Requested
15	after 2007.12.31	Hebei Weichang Longyuan Construction Investment Shanwanzi Wind farm	0.54		Ref No.2870 Registered
16	2007	Hebei Shangyi Qijiashan Wind Farm	0.5006	Fa Gai Neng Yuan [2008]1812 issued by NDRC in July 2008	Ref No.1854 Registered
17	2007	CECIC HKC Danjinghe Wind Farm	0.5006	2008 Wind Power Report	Ref No.2170 Registered
18	after 2007.12.31	CECIC HKE Zhangbei Lvnaobao Wind Power Project (100.5MW)	0.5006	Fa Gai Neng Yuan [2008] 1815 issued by NDRC in Jul 17, 2008	Ref No.3399 Registered
19	2008.7	SDIC Hebei Zhangjiakou Kangbao Pasture Wind Farm Project (100.5MW)	0.5006	Fa Gai Neng Yuan [2007] 1283	CDM under validation
20	2007	Hebei Guyuan County Dongxinying 199.5 MW Wind Power Project	0.5006	Fa Gai Neng Yuan [2008] 1325 issued by NDRC in June 2008	CDM under validation
21	2007	Hebei Chengde Yudaokou wind farm	0.551	2008 Wind Power Report	Ref No.3476 Requesting registration
22	2007.12	CECIC Zhangbei Dayangzhuang Wind Farm	0.54	Fa Gai Jia Ge [2008]1876 issued by NDRC in July 2008	Ref No.1855 Registered
23		Hebei Huifeng	0.54	Ji Jia Guan [2009]69	Ref No.1873



24		Hebei Fengze	0.54	issued by Price Bureau of Hebei province In Aug 2009 based on the Fagaijiage [2009]1906	Registered
25		Hebei Chongli Qingsanying Phase II	0.54		Ref No.1715 Registered
26		Hebei Yuxian Kongzhongcaoyuan phase II	0.54		Ref No.4123 Under completeness check
27		Hebei Kangbao sanxiatian	0.54		Under validation
28		Hebei guyuan wuhuaping	0.54		Ref No.3312 Registered
29		CECIC zhangbei phase III	0.54		Ref No.3356 Registered
30		Longyuan Baimiaotan	0.54		Ref No.1895 Registered
31		Hebei Shangyi Longyuan Wind Power Project	0.54		Under validation
32		Guohua Chicheng Dushikou West Wind Farm Project	0.54		Ref No.3704 Review Requested
33		Zhangbei bode longxiaoertai wind farm	0.54		Under validation
34		Guohua Shangyi Manjing North	0.54		Applying CDM
35		Huarun weichang yudaokou	0.54		Ref No.1792 Registered
36		Huarun yueliangshan	0.54		Applying CDM
37		Huarun dongbaliang	0.54	Ref No.1464 Registered	
38		Hebei Weichang Zhuzixia Wind power project	0.54	Ref No.1423 Registered	
39		Hebei Weichang Guangfayong Wind power project	0.54	Ref No.3743 Review Requested	
40		Hebei Chicheng Stage I Windfarm Project	0.54	Ref No.3758 Review Requested	
41		Hebei Dehe Zhangbei phase I	0.54	Ji Jia Guan [2009]98 issued by Price Bureau of Hebei province in November 2009 according to the Fa Gai Jia Ge [2009]1906 issued by NDRC	Ref No.3371 Review Requested
42		Hebei Chengde Peifeng	0.54	Ji Jia Guan [2009]108 issued by Price	Ref No.4046 Requesting registration
					Ref No.3079 Registered



43		Hebei Chengde Runfeng Wind Farm Project	0.54	Bureau of Hebei province in December 2009 according to the Fa Gai Jia Ge [2009]1906 issued by NDRC	Under validation
44	after 2007.12.31	Hebei Weichang Yangshugou Wind Power Project	0.54		Under validation
45	after 2007.12.31	Hebei Xiqiaoliang Farm Phase I Project	0.54		Under validation
46	after 2007.12.31	Hebei Weichang Dishuihu Wind power project	0.54		Under validation
The projects in Wind Resource Area IV of Hebei (rest of Hebei) #					
47	after 2007.12.31	Hebei Haixing 49.5MW Wind Farm	0.61	Fa Gai Jia Ge [2007]1260 issued by NDRC in Jun 2007	Ref No.2007 Registered
48		Huaneng Leting	0.61	Ji Jia Guan [2009]69 issued by Price Bureau of Hebei province In Aug 2009 according to the Fa Gai Jia Ge [2009]1906 issued by NDRC	Ref No.3160 Registered
49		Guohua Huanghua phase I	0.61		Ref No.2125 Registered
50		Guohua Huanghua phase II	0.61	Ji Jia Guan [2010]4 issued by Price Bureau of Hebei province In Jan 2010 according to the Fa Gai Jia Ge [2009]1906 issued by NDRC	Ref No.3021 Registered

From the above table it is confirmed that five groups of tariff are included for the wind projects in Hebei province as follow:

Group 1: 0.65RMB/kWh (incl. VAT) was excluded because it was not be comparable to the tariff used for the proposed project. Before the Electric Power Sector Reform Programme in March 2002, there were two experimental, small scale wind farms constructed with small turbines, Zhangbei Changcheng 9MW Wind Farm (13*300kW+9*600kW+2*275kW)⁷ and Chengde Hongsong 3.6MW Wind Farm (6*600kW)⁸. The approval of the tariff have been for these two projects was dated February 2002⁹, but the Zhangbei Changcheng wind farm first started to operate in 1998 and the Chengde Hongsong project started operation in 2001. Zhangbei Changcheng 9MW wind farm phase I (4.5MW) received foreign aid from the Danish government, phase II was a Double Increase project which was supported by a grant from the Chinese government. Chengde Hongsong 3.6MW wind farm project introduced experimental 600kW wind turbines which were produced by Goldwind Science & Technology Ltd, the first domestic wind turbine supplier. The objective of these two projects was to stimulate wind power development in China and stimulate the local manufacture of components, so these two early non-commercial projects received

⁷ <http://www.wp-forum.cn/ArticleShow.asp?nid=2713E111-173F-4C22-A6FF-CEB7719F4ABB>

⁸ <http://hbrb.hebnews.cn/20050617/ca503582.htm>

⁹ The approval letter of Zhangbei Changcheng wind farm, Jijiawai (1995)No1021
The approval letter of Chengde Hongsong wind farm, Jijiazizyuan (2000)No1028



a high tariff of 0.65 RMB/kWh (incl. VAT) approved by the provincial administration bureau. The Zhangbei project received ODA from Denmark and government grants from China, and the size is far less than the proposed project, and therefore is not comparable. The Chengde project used experimental equipment, and the size is far less than the proposed project, and therefore is not comparable. Both projects were implemented before the Power Sector Reform when the electricity market was not competitive and wind technology not mature in China. Therefore, the tariffs awarded to these two projects cannot be compared to the tariff awarded to the proposed project.

Group 2: 0.61RMB/kWh was excluded because four projects (No.47-No.50) of above tariff were located in Wind Resource Area IV of Hebei province, which has a less wind resource, and therefore receives higher tariffs to compensate. As stated above the “Information on the policy of wind farm on-grid tariff” (Fa Gai Jia Ge 2009(1906)) clarified that the on-grid tariff of wind farm projects depends on the wind resource area where the wind farm project is located. The proposed project is located in Wind Resource Area II of Hebei province. Therefore, the tariffs awarded to the project in Wind Resource Area IV of Hebei are not comparable to the proposed project.

Group 3: The table above shows that all other projects (No.16, No.17, No.18, No.19, and No.20) in Hebei Province greater than 50MW have the same tariff as the proposed project (0.5006 RMB/kWh (incl. VAT)), apart from the “Hebei Chengde Weichang Yudaokou Pasture 150MW Wind Farm Project (150MW)”, which uses a two phase tariff approach for different periods of operation (0.551 RMB/kWh (incl. VAT) for the first 30,000 hours of operation and 0.3664 RMB/kWh (incl. VAT) after this). So, 0.551 RMB/kWh (incl. VAT) was the highest tariff of wind power projects of which the capacity is more than 50MW.

Group 4: 0.60 RMB/kWh for six projects (No.1-No.6) which is approved by Price Bureau of Hebei province in June 2006 and located in the wind resource area II (Chengde and Zhangjiakou).

Group 5: 0.54RMB/kWh for other projects is approved by NDRC from June 2007 and located in the wind resource area II (Chengde and Zhangjiakou). The tariff of 0.54RMB/kWh was maintained stable since 2007.

Conclusion:

In China, wind projects with a capacity of less than 50MW are submitted for approval to the Provincial Development and Reform Commission, and wind projects with a capacity greater than 50MW are submitted for approval to the National Development and Reform Commission (NDRC). As the proposed project has an installed capacity of 199.5MW, it was approved by the Chinese National Development and Reform Commission and this is not comparable to the wind projects less than 50 MW in Hebei province. It can be concluded that the highest approved tariffs for wind farm projects of which the installed capacity is more than 50MW should be 0.551 RMB/kWh (incl. VAT) which was awarded to Hebei Chengde Yudaokou wind farm.

3. The highest historical tariff and the impact on additionality if this tariff is applied.

- The table shows that all other projects in Hebei Province greater than 50MW have the same tariff as the proposed project (0.5006 RMB/kWh (incl. VAT)), apart from the “Hebei Chengde Weichang Yudaokou Pasture 150MW Wind Farm Project (150MW)” (hereinafter referred to as YWP), whose tariff is 0.551 RMB/kWh (incl. VAT) for the first 30,000 hours. So the tariff awarded to YWP is considered the highest historical tariff for comparable projects whose capacity is above 50MW. Even use the tariff 0.551 RMB/kWh (incl. VAT) for the whole life of the proposed project without correcting for the changing investment circumstances, the IRR is 7.83%, which is below the benchmark.
- It was stated in the information on the policy of wind farm on-grid tariff” (Fa Gai Jia Ge 2009(1906)) that four wind resource regions are to be determined over the whole country and a guiding tariff for each region is to be determined as 0.51, 0.54, 0.58 and 0.61RMB/kWh (incl. VAT) for wind resource area I/II/III/IV, respectively. The on-grid tariff of wind farm projects will be dependent on the wind



resource area where the wind farm project is located. Hebei province is covered by two distinct wind resource areas, Wind Resource Area II in Chengde City and Zhangjiakou City of Hebei province and Wind Resource Area IV (rest of Hebei). The project is located in Zhangjiakou City, and is a Wind Resource II project. Therefore, the projects in Wind Resource Area IV of Hebei (rest of Hebei) are not comparable for the tariff analysis. In the wind resource region II, the highest tariff is 0.60RMB/kWh (incl. VAT). As the investment environment is different between comparable projects and the proposed project, not only the tariff but also the investment condition of the comparable projects should be applied in the IRR calculation sheet. As shown in the IRR calculation sheet, at 0.60RMB/kWh (incl. VAT) for the total lifetime, using the average specific investment cost and O&M cost of comparable projects, the reference tariff can be calculated as 0.5045RMB/kWh (incl. VAT), and the project would achieve an IRR of 6.53%, which is below the benchmark. Thus the project is additional on this basis.

Table 5 financial data of the project with tariff of 0.60RMB/kWh (incl. VAT)

CDM Ref No.	Project	Approved tariff (RMB/kWh) (incl. VAT)	Annual O&M costs RMB/per MWh	Installed capacity	Investment RMB/KW
VER	Chengde Hongsong wind farm project	0.6	N/A	49.8	N/A
VER	Guohua Shangyi Manjing wind farm	0.6	N/A	N/A	N/A
0842	Hebei Shangyi Manjing East Wind Farm	0.6	197	49.5	9468
0233	Zhangbei Manjing Wind Farm	0.6	N/A	45	N/A
0845	Zhangbei Mijiagou 49.5 MW Wind Farm	0.6	95	49.5	9726
0878	Hebei Kangbao Wolongtushan 30 MW Wind farm	0.6	97	30	9170
	Average	0.6	130		9454

- 0.61RMB/kWh (incl. VAT) was excluded because these projects of which the tariffs are 0.61 RMB/kWh (incl. VAT) are located in Wind Resource Area IV of Hebei province, which has a less wind resource, and therefore receives higher tariffs to compensate. Furthermore, the capacities of these projects are all below 50MW, which are not compared to the proposed project. But in order to



further confirm that the proposed project has additionality, the tariff of 0.61RMB/kWh (incl. VAT) has been applied to the IRR calculation sheet of the proposed project. As the investment environment is different between comparable projects and the proposed project, not only the tariff but also the investment condition of the comparable projects should be applied in the IRR calculation sheet. At 0.61RMB/kWh (incl. VAT) for the total lifetime, using the average specific investment cost and O&M cost of comparable projects, the reference tariff can be calculated as 0.4909RMB/kWh (incl. VAT). At this level, the project would achieve an IRR of 6.19%, which is below the benchmark, and thus the project is additional on this basis.

- Table 6 financial data of the project with tariff of 0.61RMB/kWh (incl. VAT)

CDM Ref No.	Project	Approved tariff (RMB/kWh) (incl. VAT)	Annual O&M costs RMB/per MWh	Installed capacity	Investment RMB/KW
2007	Hebei Haixing 49.5MW Wind Farm Project	0.61	74.52	49.5	10931
2125	Guohua Hebei Huanghua I 49.5 MW Wind farm Project	0.61	134.47	49.5	9938
3160	Huaneng Leting	0.61	102.18	49.5	11247
3021	Guohua Hebei Huanghua II 49.5 MW Wind farm Project	0.61	115.06	49.5	9819
	Average value	0.61	106.56		10484

- 0.65 RMB/kWh (incl. VAT) was excluded because the projects of which the tariff are 0.65 RMB/kWh (incl. VAT) have less installed capacity and early starting date, furthermore, these two projects are experimental. So these two early non-commercial projects are excluded in the tariff analysis of the proposed project. But in order to further confirm that the proposed project has additionality, the tariff of 0.65 RMB/kWh (incl. VAT) for the whole life of the project has been applied to the IRR calculation sheet of the proposed project. As the investment environment is different between two early non-commercial projects and the proposed project, not only the tariff but also the investment condition of the two early non-commercial projects should be applied in the IRR calculation sheet. At 0.65RMB/kWh (incl. VAT), using the average specific investment costs of these two projects, the reference tariff can be calculated as 0.5244RMB/kWh (incl. VAT), as shown in the spreadsheet. At this level, the project would achieve an IRR of 7.01%, which is below the benchmark, and thus the project is additional on this basis.

Table 7 financial data of the projects with tariff of 0.65RMB/kWh*

Project	Investment costs (RMB/kW)	Approved tariff(RMB/kWh,
---------	---------------------------	--------------------------



		incl. VAT)
Zhangbei Changcheng	11261	0.65
Hebei Hongsong phase I	12342	0.65
Average of projects receiving the tariff	11801.5	0.65

* For the two early demonstration projects, only the investment costs are known.

The reference tariff calculation:

The “reference tariff” is calculated based on the available information on the projects with the higher approved tariff. To quantitatively demonstrate whether the net return to the investor has been reduced or not, two calculations are made as follows:

1) Calculate the hypothetical IRR when the project faced the same situation with the projects with higher tariffs;

By introducing the average financial data for the projects with higher tariffs into the IRR spreadsheet of the proposed project to calculate the hypothetical IRR when the project faced the same situation with the projects with higher approved tariffs, the hypothetical IRR is calculated.

2) Calculate the reference tariff that makes the IRR of the proposed project equals to the hypothetical IRR;

With the hypothetical IRR calculated as above, the tariff at which the proposed project reaches the same level can be calculated. This is the reference tariff.

Conclusion

- It is shown above that the tariff used in the financial analysis is appropriate, and that the relevant highest historical tariff for the proposed project activity is 0.551 RMB/kWh (incl. VAT) and the highest historical tariff in the wind resource region II which the proposed projects is located and less-windy wind resource region IV in Hebei are 0.60 RMB/kWh (incl. VAT) and 0.61 RMB/kWh (incl. VAT) respectively. Applying these tariffs respectively, with correcting for the changing circumstances and maturing of the industry, the proposed project activity does not reach the benchmark 8% and therefore is additional.
- If it is considered that the higher tariffs awarded to two small scale demonstration projects need to be taken into account, the reference tariff taking into account the changed circumstances is calculated at 0.5244RMB/kWh (incl. VAT); using this tariff the project would not reach the benchmark. Therefore, the project is additional when using the reference tariff.
- In conclusion, the tariff used in the FSR and PDD is appropriate and conservative and has proven to be correct. The tariff is also suitable, as the slight reduction in the level of the tariff has not reduced the economic incentive for project developers.

The financial indicators (project IRR) with and without income from selling CERs are listed in the following table. Without income from selling CERs, the project IRR of the proposed project is 6.43%, lower than the benchmark IRR 8% and the proposed project is financially unacceptable because of its low profitability. While considering such income, the IRR of the proposed project is 9.26%, better than the benchmark, and then the proposed project is financially acceptable.

Table 8 Comparison of financial indicators of different scenarios with benchmark

Items	Without income from CERs	Benchmark	With income from CERs
The Project IRR	6.43%	8%	9.26%

**Sub-step 2d. Sensitivity analysis**

The objective of this sub step is to show the conclusion regarding the financial attractiveness is robust under reasonable variations of the critical assumptions.

Four factors are considered in following sensitivity analysis:

- 1) Static total investment;
- 2) Annual O&M cost;
- 3) Electricity tariff
- 4) Annual electricity output.

In China, the range of sensitivity analysis is normally chosen to be -10%~ 10% in the project investment analysis, which has been defined by *Project decision analysis and evaluation*¹⁰. And it is proper for the proposed project according to “Tool for the demonstration and assessment of additionality (Version 05.2)”. Therefore, the range of the project sensitivity analysis is chosen to be -10%~ 10%.

Assuming the above four factors vary in the range of -10% to 10%, the project IRR of the proposed project (without CERs) varies to different extent, as shown in table 9 and figure3.

Table 9 Sensitivity analysis of the project

	-10%	-5%	0%	5%	10%
Static total investment	7.73%	7.05%	6.43%	5.86%	5.33%
Annual O&M Cost	6.55%	6.49%	6.43%	6.37%	6.32%
Electricity tariff	5.20%	5.82%	6.43%	7.03%	7.62%
Annual electricity output	5.28%	5.86%	6.43%	6.99%	7.53%

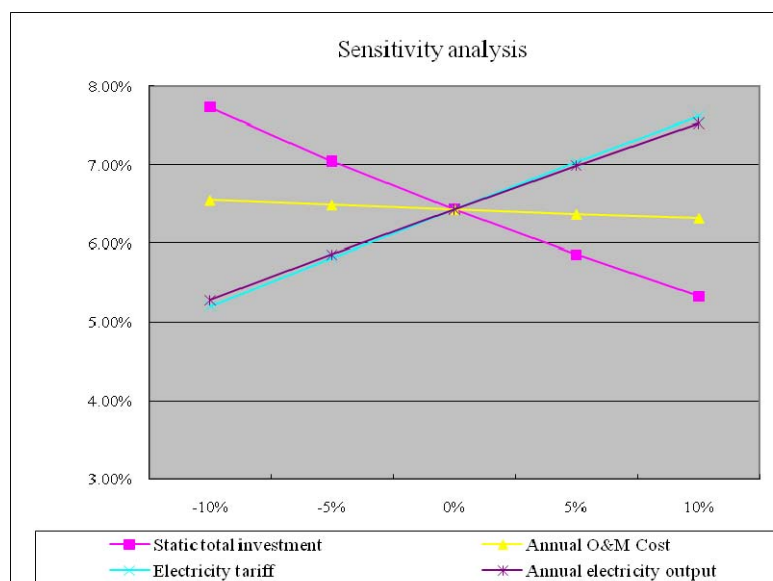

Figure 3. Sensitivity analysis of the project

Table 9 and figure 3 show that the impact of the annual electricity output and the tariff on the project IRR is the most significant. The next important factor for financial attractiveness is the total investment and the impact of the annual O&M costs takes the third place. But the IRR of the proposed project keeps lower than the benchmark when the four parameters fluctuate within the range from -10% to 10%.

The project IRR will reach the benchmark (8%) at the following assumptions, but it very unlikely happen due to:

Table 10 Parameter variation when project IRR is equal to the benchmark

¹⁰ Project decision analysis and evaluation, 2008 version, China Plan Press, P₃₉₃.



Parameters	Static total investment	Annual O&M cost	Electricity Tariff	Annual electricity output
Project IRR= Benchmark	-11.90%	-145.00%	13.30%	14.40%

- Only when the static total investment has a drop of 11.90%, the project IRR can reach the benchmark rate. However, as the prices, including those of the requirement equipment and commodities, have been increasing in recent years¹¹, a significant reduction in the level of investment is unlikely. For a wind farm project, the cost of wind turbines, wind turbine tower, engineering construction and related accessories make up the main investment. The investment is further confirmed by the purchase contracts for wind turbines, wind turbine tower purchase contract and etc., which shows that actual costs are the closed to the budget in FSR. Thus the data of total static investment in FSR and PDD is reliable, and a decrease of the fixed assets investment is unlikely.
- Only when the operation & maintenance cost has a drop of 145.00%, the project IRR can reach the benchmark rate. The O&M costs mainly include the raw material cost, maintenance cost and wages for the workers, insurance and miscellaneous cost etc. Transparently, it is impossible for the operation & maintenance cost to decrease to zero. Therefore, the operation & maintenance cost will not be changed to make the project IRR higher than or equal to the benchmark;
- The tariff 0.5006 RMB/kWh (incl. VAT) of the project has been issued by National Development and Reform Commission on 4 June 2008 (fa gai neng yuan [2008]No.1325)¹². Once the tariff is issued, it will be strictly regulated by the government; neither the project owner nor the grid company can change it. At present, the wind power tariff in China shows steady-going trend. Given the above, the tariff will not be changed to make the project IRR higher than or equal to the benchmark;
- Only when the annual electricity output increase by 14.40%, the project IRR can reach the benchmark rate. In the Approved FSR the expected annual electricity output of the proposed project were calculated based on the on-site wind data measurements from 1st May of 2006 to 31st April of 2007 and the historical wind speeds between 1971 and 2006 measured by Guyuan Meteorological Station¹³, the institute calculated the operational hours according to the *Methodology of Wind Energy Resource Assessment for Wind Farm* (GB/T18710-2002). The calculations for the project were carried out using professional WAsP software designed for wind energy, which is used by wind developers and turbines manufacturers worldwide. As the calculation were based on historical data, assuming a sustained 14.40% of increase in annual electricity output is not reasonable. Therefore, it is very unlikely for the project to become commercially attractive through an adjustment of the annual electricity output.

In a word, when financial indicators change within reasonable range, the proposed project is not financially feasible without CDM support. Therefore, *Alternative 1* is not feasible.

Step 3. Barrier analysis

The proposed project does not adopt barrier analysis.

Step 4. Common practice analysis

Sub-step 4a. Analyze other activities similar to the proposed project activity:

For the purpose of analyzing common practice, the proposed project is compared to other wind power

¹¹ http://www.stats.gov.cn/tjfx/jdfx/t20080310_402466888.htm; <http://www.86wind.com/info/detail/4-5335.html>

¹² The Approval of Guyuan Dongxinying wind power project in Hebei Province by NDRC (fa gai neng yuan [2008]No.1325)

¹³ Feasibility Study Report of the proposed project



projects which built after 2002 with installed capacity above 50MW in Hebei Province.

- A reform of unbundling generation and grid, bidding in generation has been implemented in China's electric power sector since 2002¹⁴, so the operation date of similar activities is identified from 2002.
- In China, wind projects with a capacity of less than 50MW are submitted for approval to the Provincial Development and Reform Commission, and wind projects with a capacity greater than 50MW are submitted for approval to the National Development and Reform Commission (NDRC). As the proposed project has an installed capacity of 199.5MW, it was approved by the Chinese National Development and Reform Commission and this is not comparable to the wind projects less than 50 MW in Hebei province.
- The activities in the same province have the similar wind resource, grid structure, geological and transportation conditions, economic developing status¹⁵, the former two factors affected the estimated average annual output and the later three ones affected the total investment respectively.

Therefore, the site of similar activities is identified in Hebei province. Similar activities identified with such criteria are listed in Table 11 below.

Table 11 Other project with an installed capacity greater than 50MW in Hebei province

No.	Project	Tariff(including VAT) RMB/kWh	Reference	Status
1	CECIC HKC Danjinghe Wind Farm (200MW)	0.5006	Fa Gai Neng Yuan [2007]654 issued by NDRC in Mar 2007	Registered CDM Ref No.2170
2	CECIC HKC Zhangbei Lvnaobao Wind Power Project (100.5 MW)	0.5006	Fa Gai Neng Yuan [2008]1815 issued by NDRC in Jul, 2008	Registered CDM Ref No.3399
3	Hebei Shangyi Qijiashan Wind Farm (199.5MW)	0.5006	Fa Gai Neng Yuan [2008]1812 issued by NDRC in Jul, 2008	Registered CDM Ref No.1854
4	SDIC Hebei Zhangjiakou Kangbao Pasture Wind Farm Project (100.5 MW)	0.5006	Fa Gai Neng Yuan [2007]1283	Registered CDM Ref No.3312
5	Hebei Chengde Weichang Yudaokou Pasture 150MW Wind Farm Project(150 MW)	0.551 within 30,000 hours, after that, 0.3664	Fa Gai Neng Yuan [2008]386 issued by NDRC in Feb, 2008	Under CDM validation

Data source: "Statistics of domestic wind farm installation capacity in 2007"¹⁶
<http://cdm.unfccc.int/Projects/index.html>

Sub-step 4b. Discuss any similar options that occurring.

From the "Statistics of domestic wind farm installation capacity in 2007" and other relevant data, Five

¹⁴ "Notice of National Council Issued about the Power System of Organization Reform Programme" (National issued [2002] No. 5)

¹⁵ China Wind Power Industry Development Report (2006), Shi Peng Fei, China Electric Year Book 2007

¹⁶ Shi Pengfei, Statistics of Chinese Wind Energy Installed Capacity in 2007.



Farm Projects (CECIC HKC Danjinghe Wind Farm (200MW)/ CECIC HKC Zhangbei Lvnaobao Wind Power Project (100.5 MW)/ Hebei Shangyi Qijiashan Wind Farm (199.5MW)/ SDIC Hebei Zhangjiakou Kangbao Pasture Wind Farm Project (100.5 MW)/ Hebei Chengde Weichang Yudaokou Pasture 150MW Wind Farm Project (150 MW)) are similar to the proposed project. As listed in the table 9 above, all these projects have been registered as CDM Project. Presently, without a higher supporting tariff or favorable financial support, further development of similar wind farms in Hebei province faces financial barriers and is not feasible in Hebei province. Therefore, the wind power projects similar to the proposed project are not the common practice in Hebei Province.

As stated in *Sub-step 4a and Sub-step 4b*, the proposed project is not a common practice. In conclusion, the proposed project is additional.

Conclusion of the assessment and demonstration of additionality

As seen above, the CDM revenue has been seriously considered at the early stage of the project, and it is an integral part of the financial package of the project. If the project can be registered as CDM project successfully, CDM revenue can not only cover the difference of IRR between the project and the benchmark, and resolve the financial barrier coincidentally, but also improve the confidence of investors to ensure the smooth operation of the project. And thus, the reduction of GHG will bring the corresponding social benefits, economic benefits and environment benefits as mentioned on A.2 part above.

Without CDM revenues, the duration of Internal Rate of Return will be prolonged greatly and causes the risks of project cash flow which results the failure. Thus instead of the proposed clean energy, a continuous scenario as emitting CO₂ from electricity grid will be taken place.

In a word, the proposed project is additional.

B.6. Emission Reductions

B.6.1. Explanation of methodological choices

>>

Emission reductions of the proposed project can be calculated based on the methodology ACM0002 (Version 12.1.0). The “Tool to calculate the emission factor for an electricity system”(Version 02) determines the CO₂ emission factor for the displacement of electricity generated by power plants in an electricity system, by calculating the Operating Margin (OM) and Build Margin (BM) as well as the “Combined margin” emission factor ex-ante, and through weighted average of OM and BM, the Combined Margin baseline emission factor of the NCPG can be obtained and then the emission reduction from CDM project activity can be estimated. The details are shown below:

1. Project emissions (PE_y)

According to the ACM0002 (Version 12.1.0), the emission of wind power project activity is zero, $PE_y=0$

2. Baseline emissions (BE_y)

Baseline emissions include only CO₂ emissions from electricity generation in fossil fuel fired power plants that are displaced due to the project activity, calculated as follows:

$$BE_y = EG_{PJ,y} * EF_{grid,CM,y} \quad (01)$$

Where:

BE_y	Baseline emissions in year y(tCO ₂ /y);
$EG_{PJ,y}$	Quantity of net electricity generation that is produced and fed into the grid as a result of the implementation of the CDM project activity in year y (MWh/yr);
$EF_{grid,CM,y}$	Combined Margin CO ₂ emission factor for NCPG in year y calculated using the latest version of the “Tool to calculate the emission factor for an electricity system” (Version 02) (tCO ₂ / MWh);



Since the project activity is the installation of a new grid-connected renewable power plant where no renewable power plant was operated prior to the implementation of the project activity, the $EG_{PJ,y}$ are calculated according to the following equation:

$$EG_{PJ,y} = EG_{facility,y} \quad (02)$$

Where:

- $EG_{PJ,y}$ Quantity of net electricity generation that is produced and fed into the grid as a result of the implementation of the CDM project activity in year y (MWh/yr);
- $EG_{facility,y}$ Quantity of net electricity generation supplied by the project plant/unit to the grid in year y (MWh/yr);

The “Tool to calculate the emission factor for an electricity system”(Version 02) determines the CO₂ emission factor for the displacement of electricity generated by power plants in NCPG, by calculating the “operating margin” (OM) and “build margin” (BM) as well as the “combined margin” (CM). The operating margin refers to a cohort of power plants that reflect the existing power plants whose electricity generation would be affected by the proposed CDM project activity. The build margin refers to a cohort of power units that reflect the type of power units whose construction would be affected by the proposed CDM project activity.

The following steps are applied to calculate the emission factor of NCPG:

Step 1: Identify the relevant electric power system.

The NCPG is selected as the project boundary, as:

- There is guidance available from the DNA on project boundaries identifying the applicable grid as the project boundary¹.
- The Grid is the regional grid in a country with layered dispatch system like China.

According to the guidance from China DNA, the NCPG is therefore determined as the project boundary. It is composed by Beijing City, Tianjin City, Hebei Province, Shanxi Province, Inner Mongolia and Shandong province.

The baseline emissions factor ($EF_{grid,CM,y}$) is calculated as the weighted average of the operating margin emissions factor and the build margin emissions factor. The data used to calculate the grid emissions factor comes from reliable and publicly accessible statistics e.g. China Energy Statistic Yearbook and China Electric Power Yearbook, as well as Chinese DNA.

Step 2. Choose whether to include off-grid power plants in the project electricity system

Project participants may choose between the following two options to calculate the operating margin and build margin emission factor:

Option I: Only grid power plants are included in the calculation.

Option II: Both grid power plants and off-grid power plants are included in the calculation

Regarding the proposed projects, there is no off-grid power plants included in the calculation, so option I will be used.

Step 3: Select an Operating Margin (OM) method

The calculation of the operating margin emission factor ($EF_{grid,OM,y}$) is based on one of the following methods:

- (a) Simple OM, or
- (b) Simple adjusted OM, or
- (c) Dispatch data analysis OM, or
- (d) Average OM



Considering the low cost/must run resources¹⁷ only constitute 0.89%, 0.86%, 0.76%, 0.75% and 0.79% of total generation of NCPG from the year 2002 to 2006, respectively (China Electric Power Yearbooks 2003-2007).

Based on these parameters, the simple OM method (option a) can be used for low-cost/must-run resources constitute less than 50% of total grid generation in the five most recent years.

The project electricity system is connected to NEPG and CCPG. In 2004, the electricity imports (4,514,550 MWh) from NEPG to NCPG is only 0.39% of the total generation (489,173,110 MWh) of NCPG¹⁸; In 2005, the electricity imports (3,929,000 MWh) from NEPG to NCPG is only 0.70% of the total generation (560,751,013 MWh) of NCPG¹⁹; In 2006, the electricity imports (2,618,060 MWh) from NEPG to NCPG is only 0.39% of the total generation (669,506,473 MWh) of NCPG, while the electricity imports (497,060 MWh) from CCPG to NCPG is only 0.07% of the total generation (669,506,472.9 MWh) of NCPG²⁰. Furthermore, these percentages have not changed significantly in recent years, so the average emission rates of NEPG and CCPG are taken as the emission factor of the import electricity.

Therefore, method (a) is chosen to calculate OM emission factor for the proposed project. The ex-ante option of the data vintages is chosen to calculate the emission factor of NCPG that should be documented in the CDM-PDD and not be changed during the crediting periods.

Step 4: Calculate the operating margin emission factor according to the selected method

The simple OM emission factor is calculated as the generation-weighted average CO₂ emissions per unit net electricity generation (tCO₂/MWh) of all generating power plants serving the system, not including low-cost / must-run power plants / units. It may be calculated:

Option A: Based on the net electricity generation and a CO₂ emission factor, of each power unit, or

Option B: Based on the total net electricity generation of all power plants serving the system and the fuel types and total fuel consumption of the project electricity system.

Option B can only be used if:

- (a) The necessary data for Option A is not available; and
- (b) Only nuclear and renewable power generation are considered as low-cost/must-run power sources and the quantity of electricity supplied to the grid by these sources is known; and
- (c) Off-grid power plants are not included in the calculation (i.e., if Option I has been chosen in Step 2).

For the proposed project, the data on fuel consumption, net electricity generation and the average efficiency of each power unit are unavailable, thus option A cannot be used. Nevertheless, the data on the total net electricity generation of all power plants serving the system and the fuel types and total fuel consumption of the project electricity system are available, and, nuclear and renewable power generation are considered as low-cost / must-run power sources and the quantity of electricity supplied to the grid by these sources is known, therefore, Option B can be used.

On Option B, the simple OM emission factor is calculated based on the net electricity supplied to the grid by all power plants serving the system, not including low-cost / must-run power plants / units, and based on the fuel type(s) and total fuel consumption of the project electricity system, as follows:

¹⁷ Low-cost/must-run resources are defined as power plants with low marginal generation costs or power plants that are dispatched independently of the daily or seasonal load of the grid. They typically include hydro, geothermal, wind, low-cost biomass, nuclear and solar generation. If coal is obviously used as must-run, it should also be included in this list, i.e. excluded from set of plants.

¹⁸ <China Energy Statistical Yearbook 2005>

¹⁹ <China Energy Statistical Yearbook 2006>

²⁰ <China Energy Statistical Yearbook 2007>



$$EF_{grid,OMsimple,y} = \frac{\sum FC_{i,y} \times NCV_{i,y} \times EF_{CO_2,i,y}}{EG_y} \quad (03)$$

Where:

$EF_{grid,OMsimple,y}$	Simple operating margin CO ₂ emission factor in year y (tCO ₂ /MWh);
$FC_{i,y}$	Amount of fossil fuel type i consumed in the project electricity system in year y (mass or volume unit);
NCV_i	Net calorific value (energy content) of fossil fuel type i in year y (GJ / mass or volume unit);
$EF_{CO_2,i}$	CO ₂ emission factor of fossil fuel type i in year y (tCO ₂ /GJ);
EG_y	Net electricity generated and delivered to the grid by all power sources serving the system, not including low-cost / must-run power plants / units, in year y (MWh);
i	All fossil fuel types combusted in power sources in the project electricity system in year y ;
y	The three most recent years for which data is available at the time of submission of the CDM-PDD to the DOE for validation (ex-ante option).

The simple operating margin CO₂ emission factor ($EF_{grid,OMsimple,y}$) of the NCPG is 1.1169 tCO₂/MWh. The detailed calculations and data are listed in the annex 3.

$$EF_{grid,OMsimple,y} = 1.1169 \text{ tCO}_2/\text{MWh}$$

Step 5: Identify the cohort of power units to be included in the build margin

The sample group of power units m used to calculate the build margin consists of the set of power capacity additions in the electricity system that comprise 20% of the system generation (in MWh) and that have been built most recently. This option is chosen as it comprises larger annual generation than the five units built most recently. Following the deviation²¹, the latest statistical data available (from the China Power Yearbook) is used by the DNA to determine the most recent year from which the added generation capacity is equal to or just exceeds 20% of the latest statistic year 2007. The added generation capacity is the sample group of power units m used to calculate the build margin.

In terms of vintage of data, project participants can choose between option 1 ex-ante, and option 2 ex-post data vintages. The project proponents have chosen to use the ex-ante option, and $EF_{grid,BM,y}$ is fixed for the duration of the first crediting period.

Option 1: For the first crediting period, calculate the build margin emission factor ex-ante based on the most recent information available on units already built for sample group m at the time of CDM-PDD submission to the DOE for validation. For the second crediting period, the build margin emission factor should be updated based on the most recent information available on units already built at the time of submission of the request for renewal of the crediting period to the DOE. For the third crediting period, the build margin emission factor calculated for the second crediting period should be used. This option does not require monitoring the emission factor during the crediting period.

Step 6. Calculate the build margin emission factor

The build margin emissions factor is the generation-weighted average emission factor (tCO₂/MWh) of all power units m during the most recent year y for which power generation data is available, calculated as follows:

²¹ Deviation for projects in China (DNV, 7 Oct 05), see <https://cdm.unfccc.int/Projects/deviations>



$$EF_{grid, BM, y} = \frac{\sum_m EG_{m, y} \times EF_{EL, m, y}}{\sum_m EG_{m, y}} \quad (04)$$

Where:

- $EF_{grid, BM, y}$ Build margin CO₂ emission factor in year y (tCO₂/MWh)
- $EG_{m, y}$ Net quantity of electricity generated and delivered to the grid by power unit m in year y (MWh);
- $EF_{EL, m, y}$ CO₂ emission factor of power unit m in year y (tCO₂/MWh).
- m Power units included in the build margin
- y Most recent historical year for which power generation data is available

However, even for those built most recently power plants that comprise 20% of the system generation, it is also difficult to obtain the specific data regarding fuel consumption and electricity generation additions by each power sources as confidential reason, the BM calculation in this PDD adopts the modifications methods agreed by the CDM EB. First, calculate the newly added installed capacity and the various component technologies, then calculation of the weight of newly added installed capacity of each power generation technology. Finally the commercial and efficient level of each power generation technology is adopted to calculate BM emission factor.

Because the generating capacity of the coal-fired, oil-fired and gas-fired technology can not be separated from the existing statistical data, the BM calculation in this PDD adopts the following method: First, use the available data in the energy balance tables on the most recent year, then calculate the proportion of CO₂ emissions from solid, liquid and gaseous fuels corresponding to the total emissions of CO₂ emissions. Second, the proportion used as the weight, based on the emission factors of the optimal efficient and commercial technologies, calculate the emission factor of the thermal power in each grid. Finally, this thermal emission factor is multiplied by the proportion of thermal power added capacity in the additional 20% capacity. The result is BM emission factor.

According to “Tool to calculate the emission factor for an electricity system” and clarifications by EB, the main steps for BM calculation are as following:

Sub-step 6-1: Calculation of weights of CO₂ emissions by coal-fired, oil-fired and gas-fired plants in total CO₂ emissions of NCPG.

$$\lambda_{Coal} = \frac{\sum_{i \in coal, j} F_{i, j, y} \times NCV_{i, y} \times EF_{CO_2, i, j, y}}{\sum_{i, j} F_{i, j, y} \times NCV_{i, y} \times EF_{CO_2, i, j, y}} \quad (05)$$

$$\lambda_{oil} = \frac{\sum_{i \in oil, j} F_{i, j, y} \times NCV_{i, y} \times EF_{CO_2, i, j, y}}{\sum_{i, j} F_{i, j, y} \times NCV_{i, y} \times EF_{CO_2, i, j, y}} \quad (06)$$

$$\lambda_{gas} = \frac{\sum_{i \in gas, j} F_{i, j, y} \times NCV_{i, y} \times EF_{CO_2, i, j, y}}{\sum_{i, j} F_{i, j, y} \times NCV_{i, y} \times EF_{CO_2, i, j, y}} \quad (07)$$

Where:



$F_{i,j,y}$ The total amount of fuel i (in a mass or volume unit) consumed by Province j in NCPG for power generation in year y ;

$NCV_{i,y}$ is the Net Calorific Value of fuel i (GJ/t or GJ/m³) in year y ;

$EF_{CO_2,i,j,y}$ The total amount the CO₂ emission coefficient of fuel i (tCO₂/mass or volume unit of the fuel), taking into account the carbon content of the fuels used by relevant power sources j in year(s) y

COAL, OIL, and GAS is the aggregation of various kinds of coal, oil, and gas as fossil fuels

Sub-step 5-2: Calculation of emission factor of thermal power (EF thermal power) of NCPG

$$EF_{Thermal,y} = \lambda_{Coal,y} \times EF_{Coal,Adv,y} + \lambda_{Oil,y} \times EF_{Oil,Adv,y} + \lambda_{Gas,y} \times EF_{Gas,Adv,y} \quad (08)$$

Where: $EF_{Coal,Adv,y}$, $EF_{Oil,Adv,y}$ and $EF_{Gas, Adv,y}$ are the emission factors for the best commercially available technology of coal fired power generation, oil fired power generation, and gas fired power generation respectively.

According to the statistic investigation for the new thermal power projects which were newly built during 10th Five-Year Plan period by China's State Electricity Regulatory Commission, among the newly built thermal power projects during 2000-2005, the installed capacity per turbine of 600 MW and above accounts for 21%, the capacity per turbine of 300MW accounting for 60%, and the single capacity for the remaining turbines is less than 300 MW. According to the statistic investigation by the China Electricity Council, in 2006 the capacity of all the newly built large and medium-sized thermal power projects comes to 94 GW, of which there are 64series of 600 MW sets, accounted for 40% among newly added generating capacity in the large and medium-sized thermal power projects. Summarizing the above analysis, the optimal efficiency of the commercialization of the coal fuelled technology is determined as 600 MW domestic sub critical units. The weighted average for power supply the lowest coal consumption of 30sets newly built 600 MW is chosen as the commercial and optimal technical efficiency. The supply coal consumption of domestic sub critical 600 MW power plants is estimated to be 329.94 gce/kWh, equivalent to the efficiency of power supply with 37.28%.

The commercial technology of gas turbine power plants (including oil-fired and gas-fired) with the optimal efficiency is 200 MW combined cycle (equivalent to the level of GE 9E unit). According to the relevant statistics for gas turbine power plants in 2006, the maximum practical efficiency of the gas turbine power plants is chosen as a approximate estimation for the commercial optimal efficiency. The coal consumption of the gas turbine power plants (converted by heat value) is estimated to be 252 gce/kWh, equivalent to the efficiency of power supply 48.81%.

Based on the above calculation principle for BM, basic data and parameter, the calculation process for BM is shown in annex 3

Sub-step 6-3: Calculation of Build Margin (BM) emission factor of NCPG

$$EF_{grid,BM,y} = \frac{CAP_{thermal,y}}{CAP_{Total,y}} * EF_{thermal,y} \quad (09)$$

Where:

$CAP_{Total,y}$ The total capacity addition;

$CAP_{Thermal,y}$ The fossil fuel fired capacity addition.

$EF_{thermal,y}$ Is the emissions factor of thermal power generation capacity of the applicable electricity system with the efficiency level of the best commercially available technology in China in the previous three years.

Base on the formulas above, the result is:



$EF_{grid,BM,y} = 0.8687 \text{ tCO}_2/\text{MWh}$

For the detailed information, please see the Annex 3.

For the detailed information, please see to <Notification on Determining Baseline Emission Factor of China's Grid>²².

Step 7: Calculate the combined margin emissions factor ($EF_{grid,CM,y}$)

The combined margin emissions factor is calculated as follows:

$$EF_{grid,CM,y} = EF_{grid,OM,y} * \omega_{OM} + EF_{grid,BM,y} * \omega_{BM} \quad (10)$$

Where:

$EF_{grid,CM,y}$ baseline emission factor (tCO₂e / MWh);

ω_{OM} Operation Margin weight ;

$EF_{grid,OM,y}$ Operational Margin emission factor (tCO₂e / MWh);

ω_{BM} Build Margin weight;

$EF_{grid,BM,y}$ Build Margin emission factor (tCO₂e / MWh);

y A given year.

The baseline emission factor EF_y should be calculated as the weighted average of the Operating Margin emission factor ($EF_{grid,OM,y}$) and the Build Margin emission factor ($EF_{grid,BM,y}$), where the weight of Operating Margin, ω_{OM} is 0.75 and Build Margin, ω_{BM} is 0.25 by default.

Applying the default weights for the proposed project, we calculate a Baseline Emission Factor as follows:

$$EF_{grid,CM,y} = 1.1169 * 0.75 + 0.8687 * 0.25 = 1.05485 \text{ tCO}_2/\text{MWh}$$

3. Leakage (LE_y)

According to ACM0002 (Version 12.1.0), for wind power project activities, $LE_y = 0$

4. Emission reductions (ER_y)

$$ER_y = BE_y - PE_y \quad (11)$$

Where:

ER_y are the total emissions reductions in year y (tCO₂e/yr)

PE_y are the emissions from the project activity in year y (tCO₂e/yr)

BE_y are the baseline emissions for the project activity in year y (tCO₂e/yr)

B.6.2. Data and parameters that are available at validation:

Data / Parameter:	$FC_{i,m,y}$
Data unit:	Mass or volume unit
Description:	The amount of fuel i (in a mass or volume unit) consumed by relevant power sources m in year(s) y
Source of data used:	China Energy Statistical Yearbook (2005-2007)
Value applied:	See Annex 3 for details

²² <http://cdm.ccchina.gov.cn/WebSite/CDM/UpFile/2008/20081231101111351.pdf>



Justification of the choice of data or description of measurement methods and procedures actually applied :	Official statistical data
Any comment:	-

Data / Parameter:	$NCV_{i,y}$
Data unit:	GJ/mass or volume unit of a fuel
Description:	The net calorific value (energy content) per mass or volume unit of a fuel i
Source of data used:	China Energy Statistical Yearbook 2005-2007
Value applied:	See Annex3 for details
Justification of the choice of data or description of measurement methods and procedures actually applied :	China Energy Statistical Yearbook 2005-2007
Any comment:	-

Data / Parameter:	$EF_{i,m,y}$
Data unit:	tCO ₂ /GJ
Description:	The CO ₂ emission factor per unit of energy of the fuel i .
Source of data used:	2006 IPCC Guidelines for National Greenhouse Gas Inventories
Value applied:	See Annex 3
Justification of the choice of data or description of measurement methods and procedures actually applied :	2006 IPCC Guidelines for National Greenhouse Gas Inventories
Any comment:	-

Data / Parameter:	$EG_{grid,j,y}$
Data unit:	MWh
Description:	Net electricity generated and delivered to the grid by province j in year y
Source of data used:	China Power Yearbook 2005-2007
Value applied:	See Annex 3 for details
Justification of the choice of data or description of measurement methods and procedures actually applied :	Official statistical data
Any comment:	-

Data / Parameter:	$GENE_{best,coal}$
Data unit:	
Description:	Best electricity supply efficiency for coal fired plant
Source of data used:	Notification on Determining Baseline Emission Factor of China's Grid
Value applied:	37.28%
Justification of the choice of	Official statistical data



data or description of measurement methods and procedures actually applied :	
Any comment:	-

Data / Parameter:	$GENE_{best,oil,gas}$
Data unit:	
Description:	Efficiency level of the best technology commercially available in China for gas-fired and oil-fired power generators
Source of data used:	Notification on Determining Baseline Emission Factor of China's Grid
Value applied:	48.81%
Justification of the choice of data or description of measurement methods and procedures actually applied :	Official statistical data
Any comment:	-

Data / Parameter:	$CAP_{i,y}$
Data unit:	MW
Description:	Installed capacity in each province of NCPG
Source of data used:	China Electric Power Yearbook2005-2007
Value applied:	See annex 3
Justification of the choice of data or description of measurement methods and procedures actually applied :	Official statistical data
Any comment:	-

B.6.3. Ex-ante calculation of emission reductions:

>>

According to the analysis in section B.6.1, the project emission is 0, then and $PE_y=0$ tCO₂. The combined baseline emission factor of the NCPG is:

$$EF_{grid,CM,y}=1.05485 \text{ tCO}_2\text{e/MWh.}$$

According to the Feasibility Study Report of the proposed project, the estimated annual electricity generation delivered to the power grid will be:

$$EG_{facility,y}=405,685 \text{ MWh.}$$

The annual emissions of baseline scenario are:

$$BE_{facility,y}=EG_{facility,y} \times EF_{grid,CM,y} = 405,685 \times 1.05485 = 427,936 \text{ tCO}_2\text{e.}$$

The annual emission reductions of the proposed project will be:

$$ER_y=427,936 - 0=427,936 \text{ tCO}_2\text{e/year}$$

B.6.4. Summary of the ex-ante estimation of emission reductions:

Year	Estimation of Project activity Emission	Estimation of baseline emission (tonnes of CO ₂ e)	Estimation of leakage (tonnes of CO ₂ e)	Estimation of Emission reductions
------	---	---	---	-----------------------------------



	(tonnes of CO ₂ e)			(tonnes of CO ₂ e)
01/12/2011-31/12/2011	0	35,661	0	35,661
2012	0	427,936	0	427,936
2013	0	427,936	0	427,936
2014	0	427,936	0	427,936
2015	0	427,936	0	427,936
2016	0	427,936	0	427,936
2017	0	427,936	0	427,936
01/01/2018-30/11/2018	0	392,275	0	392,275
Total estimated reductions (tonnes of CO₂e)	0	2,995,552	0	2,995,552

B.7. Application of the monitoring methodology and description of the monitoring plan:

>>

B.7.1 Data and parameters monitored:

>>

Data / Parameter:	EG _{export,y}
Data unit:	MWh
Description:	Annual electricity exported to the grid by the proposed project.
Source of data to be used:	Project activity site with electricity meter (M1).
Value of data applied for the purpose of calculating expected emission reductions in section B.5	The annual on-grid electricity supply of the proposed project is expected to be 405,685 MWh.
Description of measurement methods and procedures to be applied:	Continuously measurement and monthly recording. All data collected as part of monitoring should be archived electronically and be kept at least for 2 years after the end of the last crediting period.
QA/QC procedures to be applied:	The metering equipments at the substation will be calibrated at least once a year according to national standard.
Any comment:	-

Data / Parameter:	EG _{import,y}
Data unit:	MWh
Description:	Annual electricity imported from the grid to the proposed project.
Source of data to be used:	Project activity site with electricity meter (M1).
Value of data applied for the purpose of calculating expected emission reductions in section B.5	0MWh
Description of measurement methods and procedures to be applied:	Continuously measurement and monthly recording. All data collected as part of monitoring should be archived electronically and be kept at least for 2 years after the end of the last crediting period.
QA/QC procedures to be applied:	The metering equipments at the substation will be calibrated at least once a year according to national standard.



Any comment:	
Data / Parameter:	$EG_{\text{backuptime,y}}$
Data unit:	MWh
Description:	Electricity delivered to the project through the backup line.
Source of data to be used:	Project activity site with electricity meter (M3).
Value of data applied for the purpose of calculating expected emission reductions in section B.5	
Description of measurement methods and procedures to be applied:	Continuously measurement and monthly recording. All data collected as part of monitoring should be archived electronically and be kept at least for 2 years after the end of the last crediting period.
QA/QC procedures to be applied:	The metering equipments at the substation will be calibrated at least once a year according to national standard.
Any comment:	-

Data / Parameter:	$EG_{\text{facility,y}}$
Data unit:	MWh
Description:	Net electricity supplied to the grid by the proposed project in year y.
Source of data to be used:	Calculation
Value of data applied for the purpose of calculating expected emission reductions in section B.5	Calculation by $EG_{\text{export,y}} - EG_{\text{import,y}} - EG_{\text{backuptime,y}}$ and cross-check with sale receipts.
Description of measurement methods and procedures to be applied:	Calculation by $EG_{\text{export,y}} - EG_{\text{import,y}} - EG_{\text{backuptime,y}}$
QA/QC procedures to be applied:	Net electricity supplied to the grid by the project activity will be cross-checked with electricity sales receipts.
Any comment:	-

B.7.2. Description of the monitoring plan:

>>

The project owner, Hebei Construction Investment New Energy Co., Ltd., is the user of this monitoring plan and will be responsible for this monitoring plan. The project owner must maintain credible, transparent, and adequate data estimation, measurement, collection, and tracking systems to maintain the information required for an audit of an emission reduction project.

These records and monitoring systems are needed to allow the DOE to verify project performance as part of the verification and certification process.

Emission reductions will be achieved through displacing part of the electricity from the NCPG due to the power generated by the proposed project. The net grid-connected output is therefore defined as the key data to monitor.

The monitoring plan is established according to the request of approved baseline and monitoring methodology ACM0002 (Version 12.1.0).

1. Monitoring subject

The net electricity ($EG_{\text{facility},y}$) supplied to the grid by the project will not be measured directly. It is the difference of the following parameters.

- 1) $EG_{\text{export},y}$ is the electricity exported to the grid by the project through the main power line;
- 2) $EG_{\text{import},y}$ is the electricity imported from the grid by the project through the main power line;
- 3) $EG_{\text{backuptime},y}$ is the electricity delivered to the project through the backup line.

2. Project Integrate Management

This monitoring plan will be implemented by Hebei Construction Investment New Energy Co., Ltd., the project owner. The project manager is responsible for the implementation and monitoring of the monitoring activity. There are two departments organized for data report, quality control. There is a manager responsible for data report and quality control department. The manager will take charge of the employment administration, as well as the operation implementation and monitoring; staffs will carry on the concrete assignment based on the guide of their manager.

3. Metering System

The electricity generated by the project will be transmitted to on-site transformers which increase the voltage to 220 kV, and then delivered to Xiaochang Substation by 220kV transmission line. The simplified electrical grid connection diagram is shown in the following figure 4:

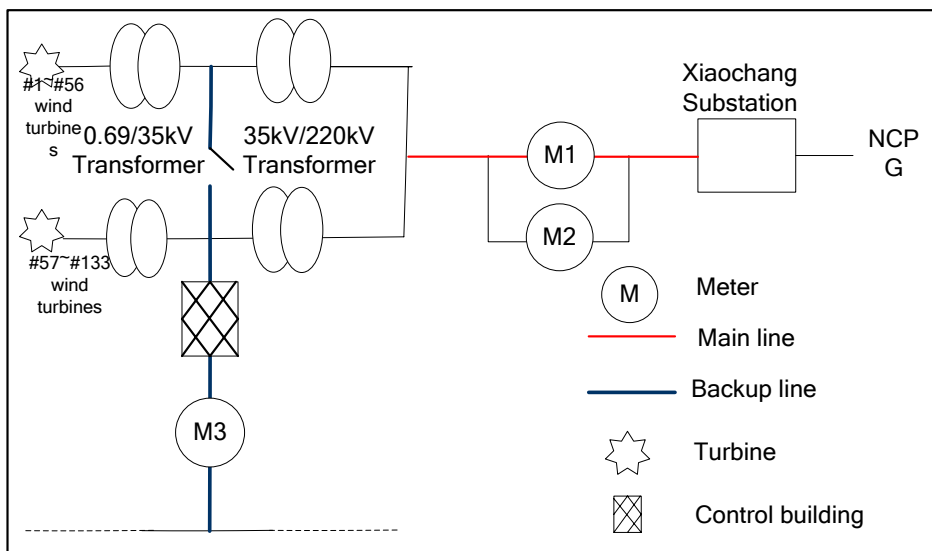

Figure 4. Simplified electrical grid connection diagram

The power line supplying electric power to the grid can also deliver power from the grid to the wind farm. The metering equipment runs in two directions and will record two readings, i.e. electricity exported to the grid ($EG_{\text{export},y}$) and electricity imported from the grid ($EG_{\text{import},y}$). Net electricity supplied to the grid is calculated as exports minus imports.

The metering system indicated by the meter instruments at M1 in Figure 4 is the main meter, while the metering system indicated by the meter instruments at M2 in Figure 4 is the backup meter. M1 is installed at 35/220 transformer higher side; M2 is installed near the point of M1 and in paralleled with M1.

In case of emergencies and when the wind farm does not produce enough power for auxiliary power use, the project will use the power through the backup line. Power delivered to the project through a backup power line ($EG_{\text{backuptime},y}$) is metered by instruments at M3 in Figure 4 which is operated by the grid company.

Net electricity supplied to the grid by the proposed project is calculated on a monthly basis as:

$$EG_{\text{facility},y} = EG_{\text{export},y} - EG_{\text{import},y} - EG_{\text{backuptime},y}$$



Where:

$EG_{\text{facility}, y}$ is the calculated power generation from the proposed project;

$EG_{\text{export}, y}$ is the electricity exported to the grid through the main power line metered by the instruments at M1;

$EG_{\text{import}, y}$ is the electricity imported from the grid through the main power line metered by the instruments at M1;

$EG_{\text{backupline}, y}$ is the electricity delivered to the project through the backup line metered by the instruments at M3.

4. Quality Assurance and Quality Control

The metering equipments will be properly calibrated and checked annually by an independent third party according to relevant national standard, e.g. the DL/T448—2000 or other national standard, to ensure its accuracy. The accuracy of all metering equipments (M1, M2 & M3) shall not be less than 0.5s.

The accuracy of metering equipments (M3) shall not be lower than 1.0.

The relative recording files will be supplied to the project owner. These recording files will be preserved by the project owner and provide to DOE in Verification.

The relevant training will be implemented by the project owner and the equipment manufacturer before operation of the proposed project.

5. Information collection and management

It is the responsibility for the project owner to provide necessary information and data for validation and verification. The measurement of the whole production data is controlled and stored by the project owner.

All physical documents including the readings in electronic and manual form of the Meters, billing receipts will be stored by the project owner and kept one copy in order to facilitate the verification of DOE.

The monthly records of power supplied to the grid and received from the grid, relevant accounting documents and billing receipts and the results of calibration shall be collected in a central place by the project owner. All data collected as part of monitoring will be kept at least for 2 years after the end of the last crediting period by the project owner.

6. Procedure in case of damaged metering equipment

In case metering equipment is damaged and no reliable readings can be recorded the project owner will estimate net supply by the proposed project activity according to the following procedure:

a. In case the main meter is damaged only:

By reading the backup meter.

b. In case both the main meter and the backup one are damaged:

The project owner and the grid company will jointly calculate a conservative estimate of power supplied to the grid. A statement will be prepared indicating

- The background to the damage to metering equipment;
- The assumptions used to estimate net supply to the grid for the days for which no record could be recorded the estimation of power supplied to the grid.

7. Monitoring Report

The Project owner will annually prepare a monitoring report which will include among others metering values of power supplied to and received from the grid, copies of electricity receipts, a report on calibration and a calculation of emission reductions.

All the data shall be kept until two years after the end of the first crediting period.

**B.8. Date of completion of the application of the baseline study and monitoring methodology and the name of the responsible person(s)/entity(ies):**

>>

The baseline study and monitoring methodology was completed on 5th September, 2008 by:

Redox International Consulting (Beijing) Co. Ltd.

Address: Suite 302, Baihuayuan Building, No.11 South Zhongguancun Street, Beijing 100081, China

Phone: +8610-68414201 E-Mail: Redox.cdm@gmail.com

(The person and organization above are not the project participants listed in Annex 1)

SECTION C. Duration of the project activity / crediting period**C.1 Duration of the project activity:****C.1.1. Starting date of the project activity:**

>>

17/08/2008(the time of the Construction Contract)

The starting date of the project activity is decided by the first time of the following four times:

The project developer and the supplier signed the Purchase Agreements of the turbine and the generator on the 29th August, 2008;

The supervisor of the proposed project signed the Starting Construction Order on the 28th August, 2008;

The supervisor of the proposed project signed the Construction Contract on the 17th August, 2008;

C.1.2. Expected operational lifetime of the project activity:

>>

22 years 0 month

C.2. Choice of the crediting period and related information:**C.2.1. Renewable crediting period**

>>

C.2.1.1. Starting date of the first crediting period:

>>

01/12/2011 (or the date of registration in EB, whichever is later)

C.2.1.2. Length of the first crediting period:

>>

7 years 0 month

C.2.2. Fixed crediting period:

>>

C.2.2.1. Starting date:

>>

Not applicable

C.2.2.2. Length:

>>

Not applicable

**SECTION D. Environmental impacts****D.1. Documentation on the analysis of the environmental impacts, including transboundary impacts:**

>>

The Environmental Impact Assessment of the proposed project was completed by Hebei Institute of Geographical Sciences, and approved by the Environment Protection Bureau of Hebei Province on 19th November, 2007 (decree number: [2007]342). Main contents of the Environmental Impact Assessment are summarized as follows:

Ecological impact**Construction Phase**

1) Impact on Foliage

The area of the buildings stated above will be all the shrub-grassland. There will be some impacts on the local vegetation during the construction period. The main impact will be eradication of local sward and the stack of earth on the lawn. But after the construction period, new trees and grass will be planted again on the site. The vegetation condition of the earth surface will recover very soon.

2) Impact on other animals

No big mammal has been found in the local area. There are only small mammals just like hare and mice. The small animals disturbed by the construction (like the snail, the angleworm, the ant) will migrate the similar habitat conditions nearby due to their strong ability of migration. So, the species diversity and population size in the area will not be obviously influenced by the proposed project during the construction phase.

3) Impact on the residents

The main air pollution sources during the construction period include dust from excavation, blasting and transportation. Some measures will be taken to reduce impact of dust, such as watering, covering and so on. In addition, the construction area is open and wide, which aids the diffusion of pollutants. Therefore, the construction will not cause much negative impact on the local air environment.

Noise will be generated by machine equipment during construction. Measures will be taken to reduce the environmental impacts of noise: choosing low-noise machines and technologies, arranging reasonable construction time, and enhancing construction management. In addition, the nearest residential area is far away from the wind farm, the neighbourhood residents will not be influenced by the noise.

So the dust and the noise generated by construction activities will have less impact on local residents.

Operation Phase

1) Impact on the local biogeocenose

There is no waste gas, waste water and solid waste in the process of wind energy. Thus, the proposed project will not obviously affect the local biogeocenose.

2) Visual Impact

The wind turbines installed in the grassland will enhance the visual value of the grassland and demonstrate the harmonious relation between human and nature. So, the proposed project has little impact on the local scene.

3) Impact on the animals

No big mammal has been found in the local area. There are only small mammals just like hare and mice. They may migrate back to the former sites after the completion of the project. Therefore, the proposed project will have less impact on other propagation during the operation phase.

**Environmental Impact****Construction phase**

For the dust emission generated during the construction period, treatment measures shall be taken, including: spraying water and enhancing construction management to avoid any influence on the ambient environment. Furthermore, the construction period is short and the local atmosphere capacity is large which aids the dust diffusion, the construction will have little influence on the local atmosphere.

The main solid waste generated from the site will be construction waste as well as the household waste from the personnel at the site. The solid waste will be carried to the landfill nearby. And both domestic sewage and the sewage from the worksite will be treated up to the standards before being discharged. So the waste and waste water generated by construction activities will have less impact on local residents.

Operation Phase

The operating noise level of the 1500kW turbine ranges from 96dB to 104dB. Since the wind farm is far away from the village, the noise levels will be controlled and naturally attenuated by ambient conditions within the standards set as *Standard of Environmental Noise of Urban Area*.

The waster water from the proposed project during operation phase will only be sewage. The sewage processed by the biological septic tank will be discharged into the collecting pond. The processed sewage will be utilized to irrigate plant in the project site without discharge. Therefore, the sewage from the proposed project during the operation phase will have less impact on the environment.

The solid waste will be mainly composed of the household garbage generated from the workers in the 220 kV booster station. The solid waste will be carried termly to the landfill nearby. Therefore, impact of solid waste on the environment is considered to be insignificant.

Conclusion

The proposed project does not have any major adverse impacts on the environment during its construction and operation phase.

D.2. If environmental impacts are considered significant by the project participants or the host Party, please provide conclusions and all references to support documentation of an environmental impact assessment undertaken in accordance with the procedures as required by the host Party:

>>

The EIA report for the proposed project indicated that the proposed project would not bring significant impacts on environment.

SECTION E. Stakeholders' comments

>>

E.1. Brief description how comments by local stakeholders have been invited and compiled:

>>

The project owner invited the comments of local stakeholders by issuing questionnaires. Hebei Construction Investment New Energy Co., Ltd carried out the survey on the local villagers and residents, the governmental officials and so on from January 2008. The survey was conducted through distributing and collecting responses to a questionnaire which was designed by project owner.

All page questionnaire were designed to be easily filled in the following sections:

- 1) Project introduction
- 2) Respondent's basic information and education level
- 3) Questions on:

What level do you know about the proposed project?	Know very well
	Know a little



	Never heard
Do you know about the Clean Development Mechanism?	Know
	Don not know
Do you think which impact on the environment may be caused by the project?	Noise caused by construction
	Waste water caused by construction
	Noise caused by turbine operation
	Impact of dust on air quality
	Use of land
	Soil and water conservation
	Construction waste
	Impact on traffic
	Impact on the surrounding eco-environment
	The interference on TV and others
Impacts of the project to local environment;	Positive effect
	Negative effect
	No effect
Impacts of the project to local economic development?	Beneficial
	Adverse
	No change
Whether to support the construction of the project?	Support
	Nonsupport

4) Space for the respondents' signature and date.

Questionnaires have been distributed according to the principle of both representation and randomness in order to reflect the public opinions and comments in a fair and real manner.

The investigated stakeholders include the individuals from the construction site and the nearby Guyuan County. The stakeholders also include the group from the government and association. The investigation has taken full account into the public advice of different ages, education levels and occupations.

In addition, public comments were invited by a poster on 12/02/2008 in all the villages within a radius of five-kilometre from the proposed project, which include Dongxinying Village, Lianhuatan Village, Taiping Village. Besides the content mentioned above, the following question was added in the Notice.

- What other comments and suggestions do the respondents have for the company regarding the Project?
- What impacts on your life may be caused by the project?

E.2. Summary of the comments received:

>>

81 valid responses from 82 questionnaires were collected and the following is a summary of the key findings:

Education level of the respondents: college and above (24.69%); junior college (44.44%); senior high school (25.93%), junior high school and others (4.94%);

Age of the respondents: 20~30(30.86%); 30~40 (39.51%); 40~50 (20.99%); others (8.64%);

Status of the respondents: resident (35.8%), government representative (25.9%), worker (24.7%), unknown (13.6%).

Summary of the survey :



Comments from the questionnaires show that 100% of the investigated stakeholders agree with the project construction, and none of them objects.

18.52% of the investigated stakeholders know something about the project while 75.31% of the investigated stakeholders know very well about the project and the others never heard it; 90.12% of them know about CDM; 87.65% of them don't think it impacting their livelihoods environment while 2.47% of them think it takes little impact of the local environment and the others think it has no impact; The fields of environmental protection the public concerned mainly include noise of the construction(6.17%) , waste water caused by construction (7.41%), noise of the operation (17.28%), construction waste (17.28%), impact of dust on air quality (1.23%), use of land (55.56%), soil and water conservation(12.35%), impact on traffic(4.94%); impact on the surrounding eco-environment (8.64%), the interference on TV and others(4.94%); 98.77% of them think it will promote the local economy. And the stakeholders are all supportive of this project.

No comments of the villagers who had seen the Notice have been received from 12/02/2008 to 12/03/2008.

In conclusion, the stakeholders are all supportive of this project.

E.3. Report on how due account was taken of any comments received:

>>

The survey shows that the project has strong local support amongst the people. All the interviewees support the construction of the project.

The fields of environmental protection which the public concerned mainly include noise, air pollution and construction waste water, use of land, soil and water conservation, impact on the surrounding eco-environment, the impact on traffic, the interference on TV and others. The EIA approved by the Environment Protection Bureau of Hebei Province shows that the noise levels would be within China national standards and no interference is expected. The developer will take some measures to reduce the dust during the construction such as watering and covering. Construction waste and waste water will be disposed of properly according to the EIA. Impact on the ecological environment and the traffic impact are very little and will be disposed of properly according to the EIA. Most of the lands for the wind farm are for temporary use, and the developer will carry out the compensation for land requisition according to state regulations. The interference on television and other receivers would be reduced the national standard. The soil and water conservation program has got the approval by the Water Resources Department of Hebei Province. The project owner will put the measures listed in the EIA into effect during construction and operation, so as to achieve environmental benefits, social benefits and economic benefits.

The villagers and local government agree with the proposed project and to date there has been not necessary to modify the project design according to the comments received.

**Annex 1****CONTACT INFORMATION ON PARTICIPANTS IN THE PROJECT ACTIVITY**

Organization:	Hebei Construction Investment New Energy Co., Ltd.
Street/P.O.Box:	No. 9 Yuhua West Road
Building:	5th Floor, Block B, Yuyuan Plaza
City:	Shijiazhuang
State/Region:	Hebei Province
Postfix/ZIP:	050000
Country:	People's Republic of China
Telephone:	+86 (311) 85278915
FAX:	+86 (311) 85278008
E-Mail:	cdmhecic@gmail.com
URL:	
Represented by:	Zhang Bo
Title:	Project Manager
Salutation:	
Last Name:	Zhang
Middle Name:	
First Name:	Bo
Department:	CDM Department
Mobile:	15803211020
Direct FAX:	+86 (311) 85278008
Direct Tel:	+86 (311) 85278915
Personal E-Mail:	zhangbo9339@126.com



Organization:	Shell Trading International Limited.(UK)
Street/P.O.Box:	80 Strand London
Building:	
City:	London
State/Region:	
Postfix/ZIP:	WC2R 0ZA
Country:	United Kingdom
Telephone:	+44 207 546 5000
FAX:	+44 207 632 9813
E-Mail:	stascoeptb@shell.com
URL:	www.shell.com
Represented by:	Ziyuan Wang
Title:	CDM Portfolio Manager
Salutation:	Ms.
Last Name:	Wang
Middle Name:	
First Name:	Ziyuan
Department:	Environmental Products Trading Business (EPTB)
Mobile:	
Direct FAX:	+44 207 632 9813
Direct Tel:	+44 207 546 5000
Personal E-Mail:	Ziyuan.wang@shell.com



ANNEX 2
INFORMATION REGARDING PUBLIC FUNDING

>>

There is no public funding from Annex I Parties involved in the project activity.



ANNEX 3 BASELINE INFORMATION

Database used for combined margin emissions factor calculation.

Baseline Information: North China Power Grid (including Beijing, Tianjin, Hebei, Shanxi, Shandong, Inner Mongolia).

The table list used for calculation the emissions reduce and combined margin ($EF_{grid,CM,y}$) (including data, data resources and course of calculation) is as follow:

Table 3-1. Low calorific values, CO₂ emission factors and oxidation factors of fuels

Table 3-2. Operating Margin Emission Factor of North China Power Grid in 2004

Table 3-3. Power transferred from the Northeast China Power Grid to the North China Power Grid in 2004

Table 3-4. Electricity Generation of North China Power Grid in 2004

Table 3-5. Operating Margin Emission Factor of North China Power Grid in 2005

Table 3-6. Power transferred from the Northeast China Power Grid to the North China Power Grid in 2005

Table 3-7. Electricity Generation of North China Power Grid in 2005

Table 3-8. Operating Margin Emission Factor of North China Power Grid in 2006

Table 3-9. Power transferred from the Northeast China Power Grid and the Central China Power Grid to the North China Power Grid in 2006

Table 3-10. Electricity Generation of North China Power Grid in 2006

Table 3-11. Operating Margin Emission Factor of North China Power Grid

Table 3-12. Calculating of the CO₂ emissions factor of fuel i (tCO₂/MWh)

Table 3-13. Calculating the percentage of CO₂ emission caused by of fuel i

Table 3-14. Installed Capacities of NCPG in 2004

Table 3-15. Installed Capacities of NCPG in 2005

Table 3-16. Installed Capacities of NCPG in 2006

Table 3-17. Installed Capacities of NCPG from 2004 to 2006

Table 3-18. Baseline Emissions Factor of North China Power Grid (tCO₂/MWh)

Table 3-1. Low calorific values, CO₂ emission factors and oxidation factors of fuels

Fuel	Low Calorific Value	Emission Factor(kgCO ₂ /TJ)
Raw Coal	20908 kJ/kg	87300
Cleaned Coal	26344 kJ/kg	87300
Other Washed Coal	8363 kJ/kg	87300
Mould Coal	20908 kJ/kg	87,300
Coke	28435 kJ/kg	95700
Crude Oil	41816 kJ/kg	71,100
Gasoline	43070 kJ/kg	67,500
Diesel Oil	42652 kJ/kg	72600
Fuel Oil	41816 kJ/kg	75,500
Other Oil Products	38369 kJ/kg	75,500
Other Coking Products	28435 kJ/kg	95,700
Natural Gas	38931 kJ/m ³	54,300
Coke Oven Gas	16726 kJ/m ³	37,300
Other Gas	5227 kJ/m ³	37,300
LPG	50179 kJ/kg	61,600
Refinery Gas	46055 kJ/kg	48,200

Data Source: The net calorific values are quoted from <China Energy Statistical Yearbook 2007>, Page 287. The emission factors and oxidation factors are quoted from <Revised 2006 IPCC Guidelines for National Greenhouse Gas Inventories>, Table 1.4, Page 1.24, Chapter 1, Volume 2.

Table 3-2: Operating Margin Emission Factor ($EF_{grid,OM,y}$) of North China Power Grid in 2004

Fuel	Unit	Beijing A	Tianjin B	Hebei C	Shanxi D	Inner Mongolia E	Shandong F	Total $G=A+B+C$ $+D+E+F$	Carbon Content (tC/TJ) H	Carbon oxidatio n rate (%) I	Average Low Calorific Value (MJ/t,km ³) J	CO ₂ Emission (tCO ₂ e) $K=G*H*I*J*44/12/1000$ 0 (for mass unit) $K=G*H*I*J*44/12/1000$ (for volume unit)
Raw Coal	10 ⁴ t	823.09	1410	6299.8	5213.2	4932.2	8550	27228.29	25.8	100	20908	538,547,477
Cleaned Coal	10 ⁴ t						40	40	25.8	100	26344	996,857
Other Washed Coal	10 ⁴ t	6.48		101.04	354.17		284.22	745.91	25.8	100	8363	5,901,191
Coke	10 ⁴ t					0.22		0.22	29.2	100	28435	6,698
Coke Oven Gas	10 ⁸ m ³	0.55		0.54	5.32	0.4	8.73	15.54	12.1	100	16726	1,153,187
Other Gas	10 ⁸ m ³	17.74		24.25	8.2	16.47	1.41	68.07	12.1	100	5227	1,578,574
Crude Oil	10 ⁴ t							0	20	100	41816	0
Gasoline	10 ⁴ t							0	18.9	100	43070	0
Diesel Oil	10 ⁴ t	0.39	0.84	4.66				5.89	20.2	100	42652	186,070
Fuel Oil	10 ⁴ t	14.66		0.16				14.82	21.1	100	41816	479,451
LPG	10 ⁴ t							0	17.2	100	50179	0
Refinery Gas	10 ⁴ t		0.55	1.42				1.97	15.7	100	46055	52,229
Natural Gas	10 ⁸ m ³		0.37		0.19			0.56	15.3	100	38931	122,306
Other Oil Products	10 ⁴ t							0	20	100	38369	0
Other Coking Products	10 ⁴ t							0	25.8	100	28435	0
Other Energy	10 ⁴ tce	9.41		34.64	109.73	4.48		158.26	0	0	0	0
											Total	549,024,041

Data Source: <China Energy Statistical Yearbook 2005>



Table 3-3: Power transferred from the Northeast China Power Grid to the North China Power Grid in 2004

Imported Power Generation from Northeast China Power Grid in 2004 (MWh)	Emission Factor of Northeast Power Grid (tCO ₂ e/ MWh)	Emission of the Imported Power Generation from Northeast Power Grid (tCO ₂ e)
4,514,550	1.1738371	5,299,346

Data Source: <China Energy Statistical Yearbook 2005>

Table 3-4: Thermal Power to North China Power Grid in 2004

Province	Electricity Generation (MWh)	Used by the Power Plant (%)	Electricity to the Grid (MWh)
Beijing	18579000	7.94	17,103,827
Tianjin	33952000	6.35	31,796,048
Hebei	124970000	6.5	116,846,950
Shanxi	104926000	7.7	96,846,698
Inner Mongolia	80427000	7.17	74,660,384
Shandong	163918000	7.32	151,919,202
Total			489,173,110

Data Source: <China Electric Power Yearbook 2005>

Table 3-5: Operating Margin Emission Factor (EF_{grid,OM,y}) of North China Power Grid in 2005

Fuel	Unit	Beijing A	Tianjin B	Hebei C	Shanxi D	Inner Mongolia E	Shandong F	Total G=A+B+C+D+E+F	Carbon Content (tC/TJ) H	Carbon oxidation rate (%) I	Average Low Calorific Value (MJ/t, km ³) J	CO ₂ Emission (tCO ₂ e) K=G*H*I*J*44/12/10000 (for mass unit) K=G*H*I*J*44/12/1000 (for volume unit)
Raw Coal	10 ⁴ t	897.75	1675.2	6726.5	6176.45	6277.23	10405.4	32158.53	25.8	100	20908	636,062,536
Cleaned Coal	10 ⁴ t						42.18	42.18	25.8	100	26344	1,051,186
Other Washed Coal	10 ⁴ t	6.57		167.4	373.65		108.69	656.36	25.8	100	8363	5,192,725



				5								
Coke	10 ⁴ t					0.21	0.11	0.32	29.2	100	28435	9,742
Coke Oven Gas	10 ⁸ m ³	0.64	0.75	0.62	21.08	0.39		23.48	12.1	100	16726	1,742,396
Other Gas	10 ⁸ m ³	16.09	7.86	38.83	9.88	18.37		91.03	12.1	100	5227	2,111,027
Crude Oil	10 ⁴ t					0.73		0.73	20	100	41816	22,385
Gasoline	10 ⁴ t			0.01				0.01	18.9	100	43070	298
Diesel Oil	10 ⁴ t	0.48		3.54		0.12		4.14	20.2	100	42652	130,786
Fuel Oil	10 ⁴ t	12.25		0.23		0.06		12.54	21.1	100	41816	405,690
LPG	10 ⁴ t							0	17.2	100	50179	0
Refinery Gas	10 ⁴ t			9.02				9.02	15.7	100	46055	239,141
Natural Gas	10 ⁸ m ³	0.28	0.08		2.76			3.12	15.3	100	38931	681,417
Other Oil Products	10 ⁴ t							0	20	100	38369	0
Other Coking Products	10 ⁴ t							0	25.8	100	28435	0
Other Energy	10 ⁴ tce	8.58		32.35	69.31	7.27	118.9	236.41	0	0	0	0
Total												647,649,331

Data Source: <China Energy Statistical Yearbook 2006>

Table 3-6: Power transferred from the Northeast China Power Grid to the North China Power Grid in 2005

Imported Power Generation from Northeast China Power Grid in 2005 (MWh)	Emission Factor of Northeast Power Grid (tCO ₂ e/ MWh)	Emission of the Imported Power Generation from Northeast Power Grid in 2005 (tCO ₂ e)
3,929,000	1.15763963	4,548,366

Data Source: <China Energy Statistical Yearbook 2006>

Table 3-7: Thermal Power to North China Power Grid in 2005

Province	Electricity Generation (MWh)	Used by the Power Plant (%)	Supplied Electricity (MWh)
Beijing	20880000	7.73	19,265,976
Tianjin	36993000	6.63	34,540,364



Hebei	134348000	6.57	125,521,336
Shanxi	128785000	7.42	119,229,153
Inner Mongolia	92345000	7.01	85,871,616
Shandong	189880000	7.14	176,322,568
Total	603231000		560,751,013

Data Source: <China Electric Power Yearbook 2006>

Table 3-8: Operating Margin Emission Factor ($EF_{grid,OM,y}$) of North China Power Grid in 2006

Fuel	Unit	Beijing A	Tianjin B	Hebei C	Shanxi D	Inner Mongolia E	Shandong F	Total G=A+B+C+D+E+F	Carbon Content (tC/TJ) H	Carbon oxidati on rate (%) I	Average Low Calorific Value (MJ/t,km ³) J	CO ₂ Emission (tCO ₂ e) K=G*H*I*J*44/12/1000 0 (for mass unit) K=G*H*I* J*44/12/1000 (for volume unit)
Raw Coal	10 ⁴ t	796.63	1639.2	6867.99	6968.88	8404.05	10930.66	35607.41	25.8	100	20908	704,277,823
Cleaned Coal	10 ⁴ t						39.77	39.77	25.8	100	26344	991,125
Other Washed Coal	10 ⁴ t	6.36		214.13	371.14	61.77	544.6	1198	25.8	100	8363	9,477,855
Mould coal	10 ⁴ t	7.97					27.77	35.74	26.6	100	20908	728,820
Coke	10 ⁴ t						3.23	3.23	29.2	100	28435	98,335
Coke Oven Gas	10 ⁸ m ³	0.38	0.63	5.8	22.32	0.64	5.79	35.56	12.1	100	16726	2,638,825
Other Gas	10 ⁸ m ³	20.66	6.58	69.72	13.79	22.76	7.22	140.73	12.1	100	5227	3,263,593
Crude Oil	10 ⁴ t					0.74		0.74	20	100	41816	22,692
Gasoline	10 ⁴ t			0.01				0.01	18.9	100	43070	298
Diesel Oil	10 ⁴ t	0.21		3.01		0.07	6.32	9.61	20.2	100	42652	303,589
Fuel Oil	10 ⁴ t	6.38		0.08			4.1	10.56	21.1	100	41816	341,633



LPG	10 ⁴ t						0.01	0.01	17.2	100	50179	316
Refinery Gas	10 ⁴ t			2.43			2.32	4.75	15.7	100	46055	125,934
Natural Gas	10 ⁸ m ³	3.41	0.73		0.53			4.67	15.3	100	38931	1,019,942
Other Oil Products	10 ⁴ t						0.28	0.28	20	100	38369	7,878
Other Coking Products	10 ⁴ t							0	25.8	100	28435	0
Other Energy	10 ⁴ tce	6.83		47.11	230.76	12.51	132.29	429.5	0	0	0	0
Total												723,298,659

Data Source: <China Energy Statistical Yearbook 2007>

Table 3-9: Power transferred from the Northeast China Power Grid and Central China Power Grid to the North China Power Grid in 2006

Imported Power Generation from Northeast China Power Grid in 2006 (MWh)	Emission Factor of Northeast Power Grid (tCO ₂ e/MWh)	Emission of the Imported Power Generation from Northeast Power Grid in 2006 (tCO ₂ e)
2,618,060	1.16687886	3,054,959
Imported Power Generation from Central China Power Grid in 2006 (MWh)	Emission Factor of Central Power Grid (tCO ₂ e/MWh)	Emission of the Imported Power Generation from Central Power Grid in 2006 (tCO ₂ e)
497,060	0.87599	435,420

Data Source: <China Energy Statistical Yearbook 2007>

Table 3-10: Thermal Power to North China Power Grid in 2006

Province	Electricity Generation (MWh)	Used by the Power Plant (%)	Supplied Electricity (MWh)
Beijing	20705000	7.51	19,150,055
Tianjin	35924000	6.86	33,459,614
Hebei	143888000	6.63	134,348,226
Shanxi	150250000	7.45	139,056,375
Inner Mongolia	139593000	7.58	129,011,851
Shandong	230922000	7.12	214,480,354



Total	721282000	669,506,473
-------	-----------	-------------

Data Source: <China Electric Power Yearbook 2007>

Table 3-11: Operating Margin Emission Factor ($EF_{grid,OM,y}$) of North China Power Grid

	2006	2005	2004	OM in average ($EF_{grid,OM,y}$)
Total supplied electricity to NCPG (MWh)	672,621,593	564,680,013	493,687,660	1.1169
Total CO ₂ emissions of NCPG (tCO ₂ e)	726,789,038	652,197,697	554,323,387	

Table 3-12: Calculating of the CO₂ emissions factor of fuel *i* (tCO₂/MWh)

	Parameter	Efficiency of Power Supply	Emission Factor of Fuel (tc/TJ)	oxidation ratio	Emission Factor(tCO ₂ /MWh)
		A	B	C	$D=3.6/A/1000 \times B \times C \times 44/12$
Coal-fired Power Plant	$EF_{Coal,Adv}$	37.28%	25.8	1	0.9135
Gas-fired Power Plant	$EF_{Gas,Adv}$	48.81%	15.3	1	0.4138
Oil-fired Power Plant	$EF_{Oil,Adv}$	48.81%	21.1	1	0.5706

Data source: *Notification on Determining Baseline Emission Factor of China's Grid, issued by China's DNA on 18th, Jul, 2008*Table 3-13: Calculating the percentage of CO₂ emission caused by of fuel *i*

Fuel	Unit	Beijing A	Tianjin B	Hebei C	Shanxi D	Shandong E	Inner Mongolia F	Total G	Average Low Calorific Value (MJ/t,km ³) H	Fuel emission factor I	Carbon oxidation rate J	CO ₂ Emission (tCO ₂ e) K=G*H*I*J*44/12/100
Raw Coal	104 t	796.63	1639.2	6867.99	6968.88	10930.66	8404.05	35607.4	20908	25.8	1	704,277,823



Cleaned Coal	104 t	0	0	0	0	39.77	0	39.77	26344	25.8	1	991,125
Other Washed Coal	104 t	6.36	0	214.13	371.14	544.6	61.77	1198	8363	25.8	1	9,477,855
Mould coal	104 t	7.97	0	0	0	27.77	0	35.74	20908	26.6	1	728,820
Coke	104 t	0	0	0	0	3.23	0	3.23	28435	29.2	1	98,335
Subtotal												715,573,958
Crude Oil	104 t	0	0	0	0	0	0.74	0.74	41816	20.0	1	22,692
Gasoline	104 t	0	0	0.01	0	0	0	0.01	43070	18.9	1	298
coal oil	104 t	0	0	0	0	0	0	0	43070	19.6	1	0
Diesel Oil	104 t	0.21	0	3.01	0	6.32	0.07	9.61	42652	20.2	1	303,589
Fuel Oil	104 t	6.38	0	0.08	0	4.1	0	10.56	41816	21.1	1	341,633
Other Oil	104 t	0	0	0	0	0.28	0	0.28	38369	20.0	1	7,878
other coking product	104 t							0	28435	25.8	1	0
Subtotal												676,091
Natural Gas	107 m3	34.1	7.3	0	5.3	0	0	46.7	38931	15.3	1	1,019,942
Coke Oven Gas	107 m3	3.8	6.3	58	223.2	57.9	6.4	355.6	16726	12.1	1	2,638,825



Other Gas	107 m3	206.6	65.8	697.2	137.9	72.2	227.6	1407.3	5227	12.1	1	3,263,593
LPG	104 t	0	0	0	0	0.01	0	0.01	50179	17.2	1	316
Refinery Gas	104 t	0	0	2.43	0	2.32	0	4.75	46055	15.7	1	125,934
Subtotal												7,048,610
Total												723,298,659

Data Source: <China Energy Statistical Yearbook 2007>

Use formulae (5) to (7) in section B.6.1, $\lambda_{Coal,y}=98.93\%$, $\lambda_{Oil,y}=0.09\%$, $\lambda_{Gas,y}=0.98\%$.

The final $EF_{Thermal}$ is calculated as follow:

$$EF_{Thermal} = EF_{Coal,Adv} \times \lambda_{Coal} + EF_{Oil,Adv} \times \lambda_{Oil} + EF_{Gas,Adv} \times \lambda_{Gas} = 0.9083 \text{tCO}_2/\text{MWh}$$

Table 3-14: Installed Capacities of NCPG in 2004

Installed Capacity	Unit	Beijing	Tianjin	Hebei	Shanxi	Inner Mongolia	Shandong	Total
Fuel-fired (MW)	MW	3458.5	6008.5	19932.7	17693.3	13641.5	32860.4	93594.9
Hydro (MW)	MW	1055.9	5	783.8	787.3	567.9	50.8	3250.7
Nuclear (MW)	MW	0	0	0	0	0	0	0
Wind & Others (MW)	MW	0	0	13.5	0	111.7	12.3	137.5
Total	MW	4514.4	6013.5	20730	18480.6	14321.2	32923.5	96983.2

Data source: China Electric Power Yearbook 2005

Table 3-15: Installed Capacities of NCPG in 2005

Installed Capacity	Unit	Beijing	Tianjin	Hebei	Shanxi	Inner Mongolia	Shandong	Total
Fuel-fired (MW)	MW	3833.5	6149.9	22333.2	22246.8	19173.3	37332	111068.7
Hydro (MW)	MW	1025	5	784.5	783	567.9	50.8	3216.2



Nuclear (MW)	MW	0	0	0	0	0	0	0
Wind & Others (MW)	MW	24	24	48	0	208.9	30.6	335.5
Total	MW	4882.5	6178.9	23165.7	23029.8	19950.2	37413.4	114620.5

Data source: China Electric Power Yearbook 2006

Table 3-16: Installed Capacities of NCPG in 2006

Installed Capacity	Unit	Beijing	Tianjin	Hebei	Shanxi	Inner Mongolia	Shandong	Total
Fuel-fired (MW)	MW	3984	6512	26087	26661	28899	49395	141538
Hydro (MW)	MW	1053	5	785	790	818	553	4004
Nuclear (MW)	MW	0	0	0	0	0	0	0
Wind & Others (MW)	MW	24	24	218	0	565	106	937
Total	MW	5061	6541	27090	27451	30282	50054	146479

Data source: China Electric Power Yearbook 2007

Table 3-17: Installed Capacity of NCPG from 2004 to 2006

	2004	2005	2006	New Capacity Additions from Year2005-2006	Percentage of newly added installed Capacity
	A	B	C	D=C-B	
Fuel-fired (MW)	93594.9	111068.7	141538	30469.3	95.64%
Hydro (MW)	3250.7	3216.2	4004	787.8	2.47%
Nuclear (MW)	0	0	0	0	0.00%
Wind & Others (MW)	137.5	335.5	937	601.5	1.89%
Total(MW)	96983.2	114620.4	146479	31858.6	100.00%
Percentage of newly added installed Capacity to 2006	66.21%	78.25%	100%		

The Build Margin Emission Factor in North China Power Grid is:

$$EF_{\text{grid,BM},y} = 0.9083 \times 95.64\% = 0.8687 \text{ tCO}_2/\text{MWh}$$

$$EF_{\text{grid,CM},y} = 1.1169 \times 0.75 + 0.8687 \times 0.25 = 1.05485 \text{ tCO}_2/\text{MWh}$$

Table 3-18: Baseline Emissions Factor of North China Power Grid (tCO₂/MWh)

Parameter	Unit	Value
$EF_{grid,OM,y}$	tCO ₂ e/MWh	1.1169
$EF_{grid,BM,y}$	tCO ₂ e/MWh	0.8687
$EF_{grid,CM,y}$	tCO ₂ e/MWh	1.05485



Annex 4
MONITORING PLAN

This plan will be carried out to monitor the electricity supply and the balance document between the grid company and the project sponsor. Please refer to B7.2 for the detailed description of monitoring plan.

Further clarifications on requirements as per VCS Standard version 3.2

Hebei Guyuan County Dongxingying 199.5 MW Wind Power Project (hereinafter referred to as the project) has been already registered under CDM¹, another GHG program approved by VCS. As per VCS relevant requirements specified in VCS standard version 3.2 for projects validated under the CDM, sections 1.2, 1.3, 1.5, 1.6, 1.7, 1.9, 1.10, 1.12.1, 1.12.2, 1.12.3, 1.12.4 and 1.13 are further clarified and/or elaborated as follows:

1.2 Sectoral Scope and Project Type

The project falls in Sectoral scope I: Energy Industries (renewable sources).

The project is a new grid-connected renewable wind power plant and not a grouped project as per definition of Grouped Project.

1.3 Project Proponent

Project proponent: Hebei Construction Investment New Energy Co., Ltd.

Contact information:

Guang Du, project manager

Tel: +86-(0)311-8551 8612, Fax: +86-(0)311-8527 8008, E-mail: duguang_0915@163.com

1.5 Project Start Date

25-May-2010, the date on which the first WTG of the Project started to deliver electricity to the grid.

1.6 Project Crediting Period

The VCS crediting period is from 25-May-2010 to 14-September-2011, which is not overlapped with the CDM crediting period (15-September-2011~14-September-2018).

1.7 Project Scale and Estimated GHG Emission Reductions or Removals

Project	Yes
Mega-project	N/A

The estimated annual GHG emission reductions of the Project are 427,936 tCO₂e. The estimated GHG Emission Reductions during the VCS crediting period are calculated as follows:

Years	Estimated GHG emission reductions or removals (tCO ₂ e)

¹ UNFCCC Ref. No. 4853, <http://cdm.unfccc.int/Projects/DB/TUEV-RHEIN1306303373.74/view>

25-May-2010~31-Dec.-2010	259,106 ²
01-Jan.-2011~14-Sep.-2011	301,314 ³
Total estimated ERs	560,420
Total number of crediting years	One year and 113 days
Average annual ERs	427,936

1.9 Project Location

The project is located in south of Guyuan County, Zhangjiakou City, Hebei Province, P.R.China. The geographical coordinates of the project are 115.2997°~115.7508°E, 41.3169°~41.5661°N.

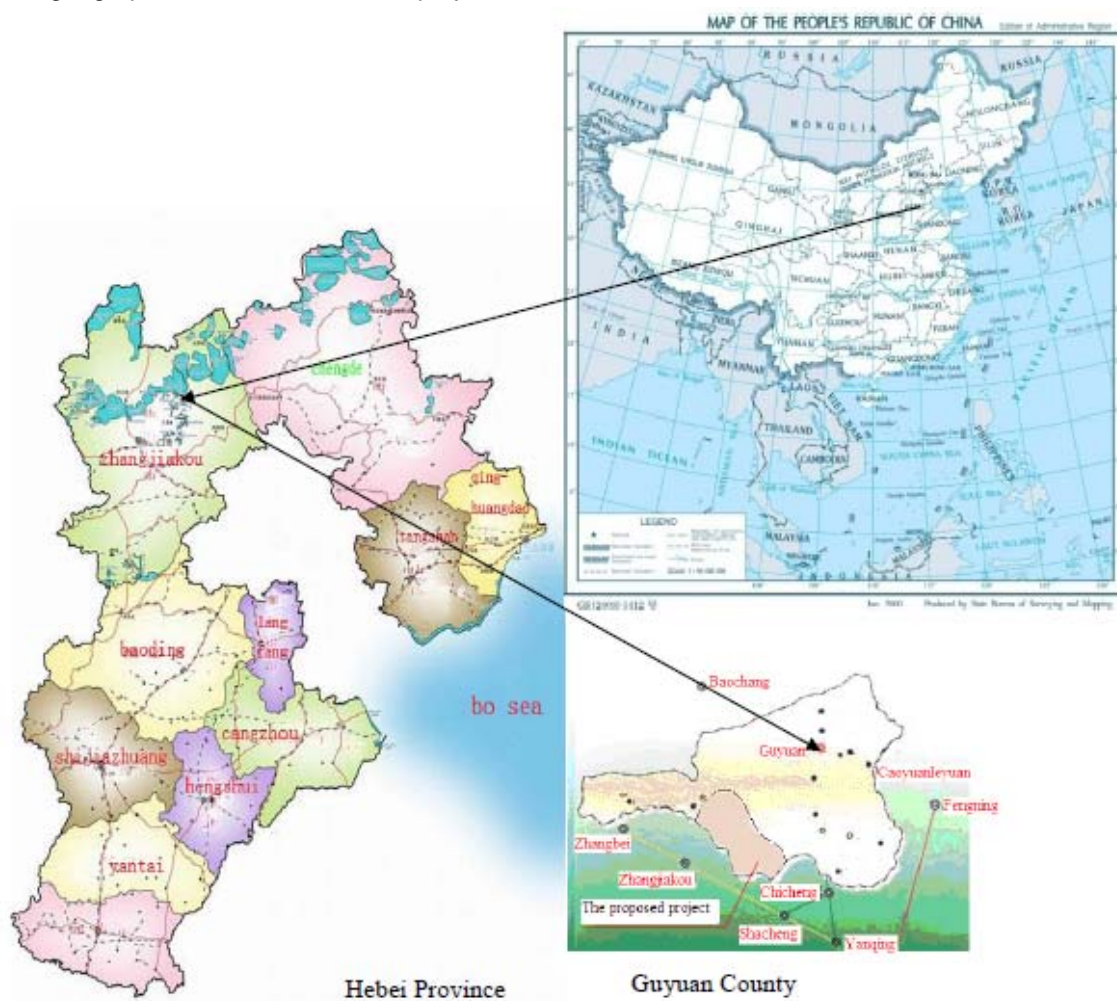

² This time period covers 221 days. It is calculated as: $427,936/365 \times 221 = 259,106$ tCO₂e

³ This time period covers 257 days. It is calculated as: $427,936/365 \times 257 = 301,314$ tCO₂e

1.10 Conditions Prior to Project Initiation

The scenario existing prior to the start of the implementation of the project is that local electricity service is provided by the North China Power Grid where the project is located.

The purpose of the project is to generate renewable power by wind energy to replace power from North China Power Grid which is dominated by fossil-fuel fired power plants. The total capacity of the proposed project is 199.5 MW and a total of 133 wind turbines with 1,500 kW per-unit capacities were installed. The wind turbines will turn wind resource into clean electricity which will be exported to the NCPG. Since the project does not generate GHG emissions, the implementation of the project was not to generate GHG emissions primarily for the purpose of its subsequent removal or destruction.

1.12 Ownership and Other Programs

1.12.1 Proof of Title

Letter of Approval issued by China's DNA for the Project can serve as the proof of title of the Project Owner. As described in the Letter of Approval, Hebei Construction Investment New Energy Co., Ltd. is authorized as China's project participant to voluntarily participate in and carry out the project.

The Project Owner has also obtained all relevant permits to the project including Business License, and Power Purchase Agreement. Moreover, the ownership of the Project Owner was described in the registered CDM-PDD.

1.12.2 Emissions Trading Programs and Other Binding Limits

N/A.

The Project has been registered as a CDM project on 15-Sep.-2011. Only GHG emission reductions achieved from the starting date of the Project 25-May-2010 to 14-Sep.-2011 could be verified as VCUs under the VCS version 3.2.

1.12.3 Participation under Other GHG Programs

The project was registered as a CDM project on 15-Sep.-2011 with UNFCCC Ref, No. 4853. Only emission reductions achieved from 25-May-2010 to 14-Sep.-2011 will be considered as VCUs under VCS Standard v3.2. Thus, no double counting would occur.

The project is invested and operated by Hebei Construction Investment New Energy Co., Ltd. TUV Rheinland was commissioned as DOE to perform validation under the CDM and issued Validation Report on 08-Sep.-2011 which could be considered as validation completion date in accordance with relevant requirements on it. Moreover, the validation date is prior to 24-May.-2012 and thus is within two years of the project start date.

1.12.4 Other Forms of Environmental Credit

The project was registered as a CDM project on 15-Sep.-2011 with UNFCCC Ref, No. 4853 and will generate CERs from 15-Sep.-2011 on. Only emission reductions achieved from 25-May-2010 to 14-Sep.-2011 will be considered as VCUs under VCS Standard v3.2. Thus, no double counting would occur. The project neither has no intends to generate any other form of GHG-related environmental credit claimed under the VCS program, other than CO₂ emission reductions.

1.13 Additional Information Relevant to the Project

Eligibility Criteria

Not applicable. The project is not a grouped project.

Leakage Management

According to the CDM consolidated baseline methodology ACM0002, the leakage of the proposed project is not considered for this project.

Commercially Sensitive Information

No information has been excluded from the public version of the project description as the information is considered as commercially sensitive information.

Further Information

N/A