

**MONITORING REPORT FORM (F-CDM-MR)
Version 02.0****MONITORING REPORT**

Title of the project activity	Hebei Guyuan County Dongxinying199.5MW Wind Power Project
Reference number of the project activity	4853
Version number of the monitoring report	02
Completion date of the monitoring report	04/09/2012
Registration date of the project activity	15/09/2011
Monitoring period number and duration of this monitoring period	Monitoring period number 1 from 15/09/2011 to 09/01/2012
Project participant(s)	Hebei Construction Investment New Energy Co., Ltd. Shell Trading International Limited.(UK)
Host Party(ies)	China
Sectoral scope(s) and applied methodology(ies)	Sectoral scope(s): 1-Energy industries and ACM 0002 Version 12.1.0
Estimated amount of GHG emission reductions or net anthropogenic GHG removals by sinks for this monitoring period in the registered PDD	137,174tCO ₂ e
Actual GHG emission reductions or net anthropogenic GHG removals by sinks achieved in this monitoring period	114,391tCO ₂ e



SECTION A. Description of project activity

A.1. Purpose and general description of project activity

>>

The objective of Hebei Guyuan County Dongxinying 199.5MW Wind Power Project (hereinafter referred to as the project) is to generate electricity using wind energy and to sell the generated output to North China Power Grid (NCPG). Total installed capacity of the project is 199.5MW, involving 133 sets of wind turbine-generator (hereinafter referred to as WTG), each set with a rated capacity of 1.5MW. Applying grid-connected electricity generation by wind energy technology and by displacing equal amount electricity generated by NCPG which is dominated by fossil fuel-fired power plants, the project contributes to annual GHG reductions estimated at 427,936tCO_{2e}.

The main equipments of the project are 133 sets of WTGs manufactured by Dongfang Steam Turbine Co., Ltd.

Relevant dates for the project are as follows:

- The date to start construction: 25/08/2008¹
- The date of first wind turbine started operation : 25/05/2010²
- The date of all 133 WTGs started full operation: 06/10/2010²
- CDM registration date: 15/09/2011
- CDM crediting period(Renewable) : 15/09/2011 - 14/09/2018

In this monitoring period, 114,391t CO_{2e} emission reductions were achieved.

A.2. Location of project activity

>>

The project is located in southern area of Guyuan County, Zhangjiakou City, Hebei Province, P.R.China. The GPS coordinates of the geographical area the project covered are 115.2997° E~115.7508°E, 41.3169°N~41.5661°N. The location of the project is shown in figure 1:

¹As per the *Construction Start Order*, the construction start date is 25/08/2008

²As per Daily Operation Record, the first WTG and last WTG were put into operation on 25/05/2010 and 06/10/2010 respectively.

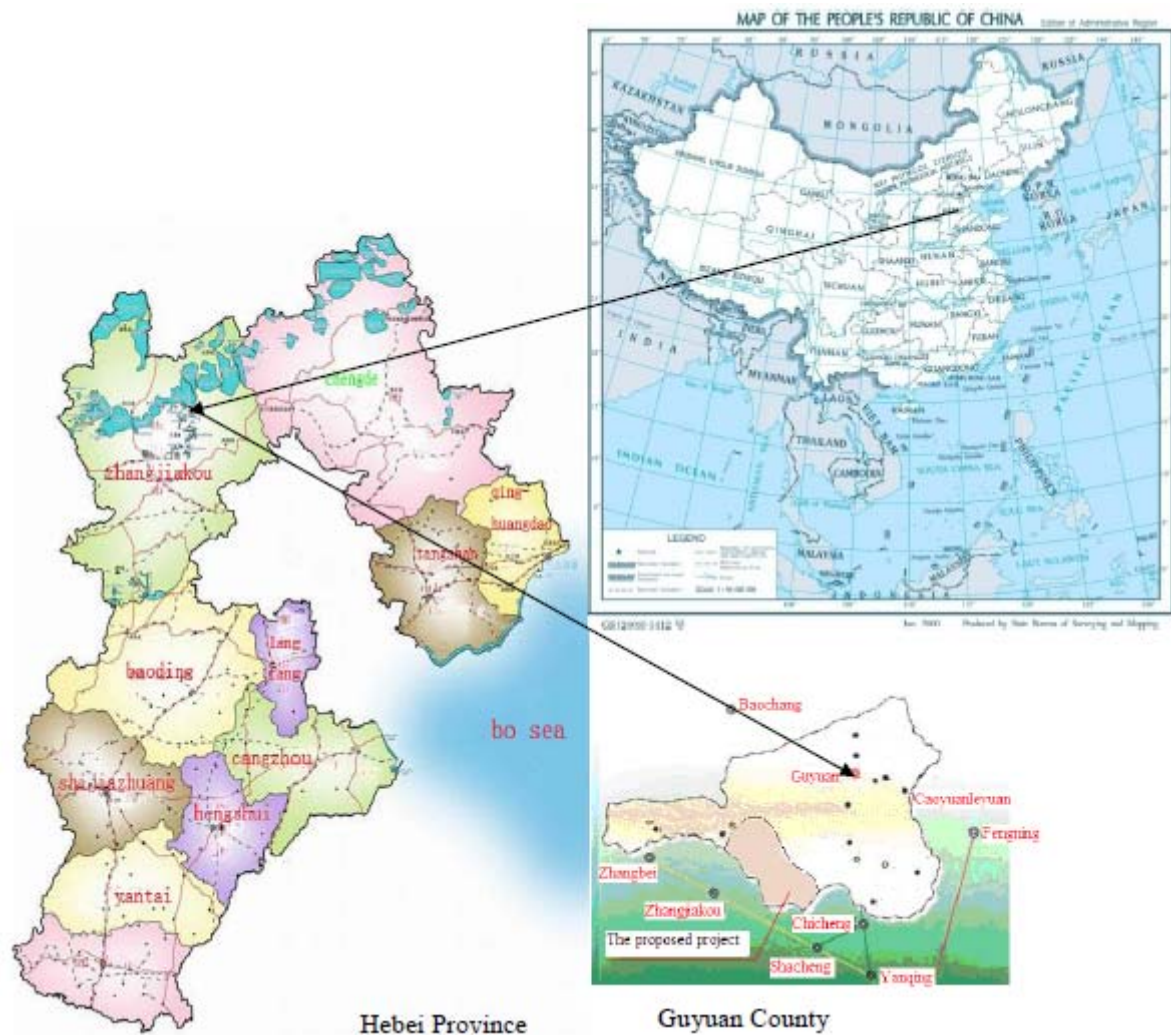

Figure 1 The location of the project

A.3. Parties and project participant(s)

Party involved (host) indicates a host Party)	Private and/or public entity(ies) project participants (as applicable)	Indicate if the Party involved wishes to be considered as project participant (Yes/No)
People’s Republic of China(host)	Hebei Construction Investment New Energy Co., Ltd.	No
United Kingdom of Great Britain and Northern Ireland	Shell Trading International Limited.(UK)	No

A.4. Reference of applied methodology

>>

The project applies the approved consolidated baseline and monitoring methodology ACM0002 “Consolidated baseline methodology for grid-connected electricity generation from renewable sources” (Version 12.1.0).

The methodology also refers to the latest approved versions of the following tools:

- Tool to calculate the emission factor for an electricity system (Version 02);
- Tool for the demonstration and assessment of additionality (Version 05.2);

For more information regarding the methodology and the tools as well as their consideration by the Executive Board, please refer to <http://cdm.unfccc.int/methodologies/PAMethodologies/approved.html>

A.5. Crediting period of project activity

>>

A 7yrs×3 renewable crediting period has been chosen by the project. The first crediting period is from 15/09/2011 to 14/09/2018. The start date of the crediting period has been requested to change from 01/12/2011 to 15/09/2011 and the request has been accepted by the Board.

SECTION B. Implementation of project activity

B.1. Description of implemented registered project activity

>>

The project has been put into operation since 25/05/2010. During this monitoring period, the project was under normal and smooth operation as per the registered CDM PDD (version 6.0) without any emergencies or special events including overhaul times, downtimes of equipment, exchange of equipment.

The project applies WTG-box transformer unit to boost voltage of the generated electricity from 690V to 35kV. Then the electricity will be transmitted to the main transformers via 35kV collection lines. After boosted its voltage to 220kV by the main transformers, the electricity will be transmitted to Xiaochang Substation and exported to NCPG.

The main equipments of the project are 133 sets of WTGs manufactured by Dongfang Steam Turbine Co., Ltd. Key technical parameters are listed in table 1.

Table 1 Key technical parameters of the WTG

Parameter	Unit	Value
Type of turbine	-	FD77B
Type of generator	-	double-fed asynchronous motor
Nominal output	kW	1500
Rotor diameter	m	77
Hub height	m	61.5
Rated voltage	V	690
Cut-in wind speed	m/s	3
Nominal wind speed	m/s	12

B.2. Post registration changes

B.2.1. Temporary deviations from registered monitoring plan or applied methodology

>>

N/A

B.2.2. Corrections

>>

N/A

B.2.3. Permanent changes from registered monitoring plan or applied methodology

>>

N/A

B.2.4. Changes to project design of registered project activity

>>

N/A

B.2.5. Changes to start date of crediting period

>>

The start date of the crediting period has been requested to change from 01/12/2011 to 15/09/2011 and the request has been accepted by the Board.

B.2.6. Types of changes specific to afforestation or reforestation project activity

>>

N/A

SECTION C. Description of monitoring system

>>

The project owner, Hebei Construction Investment New Energy Co., Ltd., is the user of this monitoring plan and is responsible for this monitoring plan. The project owner must maintain credible, transparent, and adequate data estimation, measurement, collection, and tracking systems to maintain the information required for an audit of an emission reduction project.

These records and monitoring systems are needed to allow the DOE to verify project performance as part of the verification and certification process.

Emission reductions are achieved through displacing part of the electricity from the NCPG due to the power generated by the proposed project. The net grid-connected output is therefore defined as the key data to monitor.

The monitoring plan is established according to the request of approved baseline and monitoring methodology ACM0002 (Version 12.1.0).

1. Monitoring subject

The net electricity ($EG_{\text{facility},y}$) supplied to the grid by the project is not measured directly. It is the difference of the following parameters.

- 1) $EG_{\text{export},y}$ is the electricity exported to the grid by the project through the main power line;
- 2) $EG_{\text{import},y}$ is the electricity imported from the grid by the project through the main power line;
- 3) $EG_{\text{backupline},y}$ is the electricity delivered to the project through the backup line.

2. Project Integrate Management

This monitoring plan has been implemented by Hebei Construction Investment New Energy Co., Ltd., the project owner. The management structure is shown in the figure below:

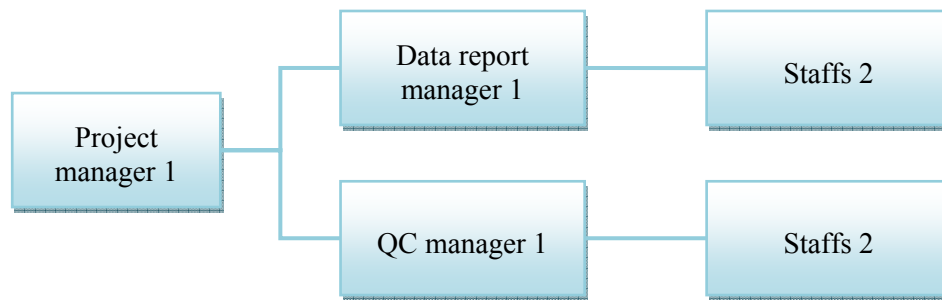

Figure 2 Management structure of the project

The project manager is overall responsible for the implementation and monitoring of the monitoring activity. As subordinates of the Project Manager, two low-level managers are responsible for concrete works, that is, Data report Manager, with assist of 2 staffs, mainly takes charge of recording, aggregating and archiving necessary data in accordance to the monitoring plan; QC Manager is in charge of quality control of the monitoring system, for example, supervising the data recording procedures, cross checking the records of meter readings with data source from the third party, etc..

3. Metering System

The electricity generated by the project will be transmitted to on-site transformers which increase the voltage to 220 kV, and then delivered to Xiaochang Substation by 220kV transmission line. The simplified electrical grid connection diagram is shown in the following figure 3.

The power line supplying electric power to the grid can also deliver power from the grid to the wind farm. The metering equipment runs in two directions and record two readings, i.e. electricity exported to the grid ($EG_{\text{export},y}$) and electricity imported from the grid ($EG_{\text{import},y}$). Net electricity supplied to the grid is calculated as exports minus imports.

The metering system indicated by the meter instruments at M1 in Figure 2 is the main meter, while the metering system indicated by the meter instruments at M2 in Figure 2 is the backup meter. M1 is installed at 35/220 transformer higher side; M2 is installed near the point of M1 and in paralleled with M1.

In case of emergencies and when the wind farm does not produce enough power for auxiliary power use, the project uses the power through the backup line. Power delivered to the project through a backup power line ($EG_{\text{backupline},y}$) is metered by instruments at M3 in Figure 4 which is operated by the grid company.

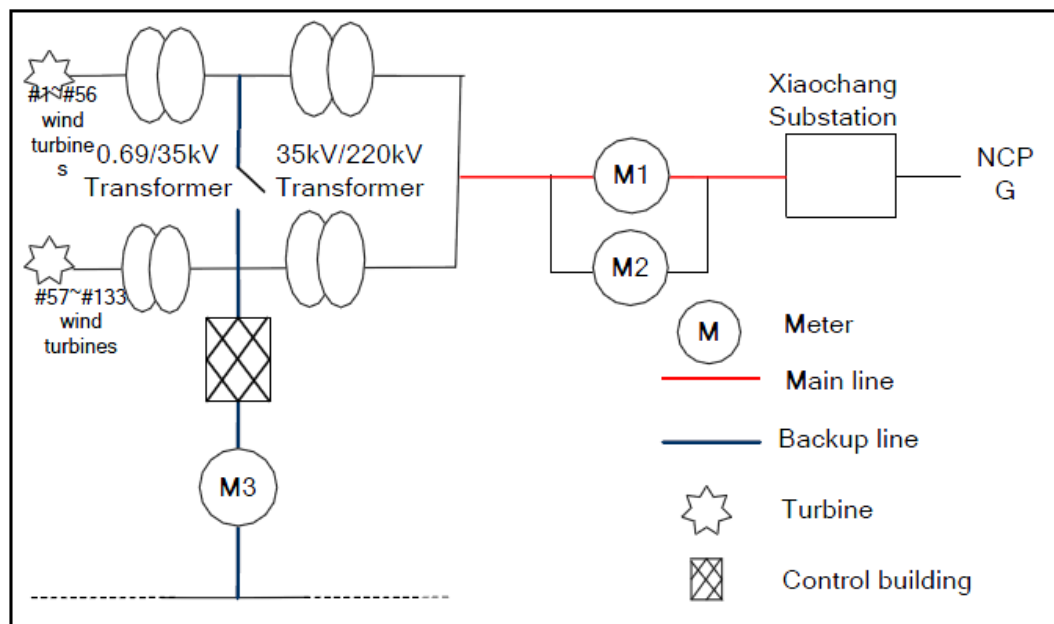

Figure 3 Simplified electrical grid connection diagram

Net electricity supplied to the grid by the proposed project is calculated on a monthly basis as:

$$EG_{\text{facility}, y} = EG_{\text{export}, y} - EG_{\text{import}, y} - EG_{\text{backupline}, y}$$

Where:

$EG_{\text{facility}, y}$ is the calculated power generation from the proposed project;

$EG_{\text{export}, y}$ is the electricity exported to the grid through the main power line metered by the instruments at M1;

$EG_{\text{import}, y}$ is the electricity imported from the grid through the main power line metered by the instruments at M1;

$EG_{\text{backupline}, y}$ is the electricity delivered to the project through the backup line metered by the instruments at M3.

4. Data collection procedures

The electricity exported to grid by the project ($EG_{\text{export}, y}$) or imported to the grid from the grid ($EG_{\text{import}, y}$ and $EG_{\text{backupline}, y}$) is continuously measured by installed meters (M1, M2&M3). Meter M1, M2 and M3 are daily read and recorded in Daily Meter Reading Record by the project owner and Grid Company. For cut-off, the start reading and end reading of all meters is also recorded at end of each month in monthly meter reading record. Sales receipts are issued by the grid company base on monthly meter readings and sales receipts are used for crosscheck. For the two incomplete month (15/09/2011~30/09/2011 and 01/01/2012~09/01/2012), the values for the parameters ($EG_{\text{export}, y}$, $EG_{\text{import}, y}$ and $EG_{\text{backupline}, y}$) is obtained from Daily Meter Reading Record and are confirmed by the grid company.

All collected data are stored as electronic format for at least two years after the end of the first crediting period.

5. Quality Assurance and Quality Control

The metering equipments are properly calibrated and checked annually by an independent third party according to relevant national standard, e.g. the DL/T448—2000 or other national standard, to ensure its accuracy. The accuracy of all metering equipments (M1, M2&M3) shall not be less than 0.5s.



The relative recording files were supplied to the project owner. These recording files were preserved by the project owner and provide to DOE in Verification.

The relevant training was implemented by the project owner and the equipment manufacturer before operation of the proposed project.

6. Information collection and management

It is the responsibility for the project owner to provide necessary information and data for validation and verification. The measurement of the whole production data is controlled and stored by the project owner.

All physical documents including the readings in electronic and manual form of the Meters, billing receipts are stored by the project owner and kept one copy in order to facilitate the verification of DOE.

The monthly records of power supplied to the grid and received from the grid, relevant accounting documents and billing receipts and the results of calibration shall be collected in a central place by the project owner. All data collected as part of monitoring are kept at least for 2 years after the end of the last crediting period by the project owner.

7. Procedure in case of damaged metering equipment

In case metering equipment is damaged and no reliable readings can be recorded the project owner will estimate net supply by the proposed project activity according to the following procedure:

a. In case the main meter is damaged only:

By reading the backup meter.

b. In case both the main meter and the backup one are damaged:

The project owner and the grid company will jointly calculate a conservative estimate of power supplied to the grid. A statement will be prepared indicating

- The background to the damage to metering equipment;
- The assumptions used to estimate net supply to the grid for the days for which no record could be recorded the estimation of power supplied to the grid.

8. Monitoring Report

The Project owner will annually prepare a monitoring report which will include among others metering values of power supplied to and received from the grid, copies of electricity receipts, a report on calibration and calculation of emission reductions.

All the data shall be kept until two years after the end of the first crediting period.

SECTION D. Data and parameters

D.1. Data and parameters fixed ex ante or at renewal of crediting period

Data/Parameter	$EF_{Grid,CM,y}$
Unit	t CO ₂ e/MWh
Description	Baseline emission factor
Source of data	Registered CDM PDD
Value(s) applied	1.05485
Purpose of data	It is used for baseline emission reduction calculation

Additional comment	This parameter is ex-ante determined in the registered CDM-PDD and fixed in the first crediting period.
---------------------------	---

D.2. Data and parameters monitored

Data/Parameter	EG_{export,y}		
Unit	MWh		
Description	The electricity exported to the grid through the main power line metered by the instruments at M1		
Measured/Calculated /Default	Measured		
Source of data	Project activity site (measured by meter M1)		
Value(s) of monitored parameter	108,622.800		
Monitoring equipment	Name	M ₁	M ₂
	Type	ACE8000	ACE8000
	Accuracy class	0.2S	0.2S
	Serial number	ZG37006406	ZG37006391
	Calibration frequency	Annually	Annually
	Validity	yes	yes
	Date of calibration	13/12/2010; 12/12/2011.	13/12/2010; 12/12/2011.
	Calibration institute ³	Zhangjiakou Electric Energy Measurement Centre	
Measuring/Reading/Recording frequency	Measuring continuously and Recording monthly Actually this parameter is continuously measured and daily recorded. If needed, the monitoring data can be presented using appropriate time interval.		
Calculation method (if applicable)	N/A		
QA/QC procedures	Calibration has been conducted to guarantee the accuracy and normal functions of M1 and its backup meter M2, according to relevant national or industrial standards by qualified institution; Sales receipts are used for cross-check.		
Purpose of data	Used for baseline emission calculation		
Additional comment	-		

Data/Parameter	EG_{import,y}		
Unit	MWh		
Description	The electricity imported from the grid through the main power line metered by the instruments at M1		
Measured/Calculated	Measured		

³Calibration to all meters was conducted by Zhangjiakou Electric Energy Measurement Centre, with the certificate code of (Ji) FaJi[2008] No.D011 which is valid from 18/02/2008 to 17/02/2011 and Approval letter of extending the authorisation period to 31/12/2011 with code of JiZhijianhan No. (2011) 145, granted by Bureau of Quality and Technical Supervision of Hebei Province.



/Default			
Source of data	Project activity site (measured by meter M1)		
Value(s) of monitored parameter	179.025		
Monitoring equipment	Name	M1	M2
	Type	ACE8000	ACE8000
	Accuracy class	0.2S	0.2S
	Serial number	ZG37006406	ZG37006391
	Calibration frequency	Annually	Annually
	Validity	yes	yes
	Date of calibration	13/12/2010; 12/12/2011.	13/12/2010; 12/12/2011.
	Calibration institute	Zhangjiakou Electric Energy Measurement Centre	
Measuring/Reading/Recording frequency	Measuring continuously and Recording monthly Actually this parameter is continuously measured and daily recorded. If needed, the monitoring data can be presented using appropriate time interval.		
Calculation method (if applicable)	N/A		
QA/QC procedures	Calibration has been conducted to guarantee the accuracy and normal functions of M1 and its backup meter M2, according to relevant national or industrial standards by qualified institution. Sales receipts are used for cross-check.		
Purpose of data	Used for baseline emission calculation		
Additional comment	-		

Data/Parameter	EG_{backupline,y}			
Unit	MWh			
Description	The electricity delivered to the project through the backup line metered by the instruments at M3.			
Measured/Calculated/Default	Measured			
Source of data	Project activity site (measured by meter M3)			
Value(s) of monitored parameter	0.000			
Monitoring equipment	Name	M3	Serial number	B24T0P812403001807
	Type	DSSD22	Date of Calibration	13/12/2010; 12/12/2011
	Accuracy	0.5S	Calibration frequency	annually
	Validity	yes		
Measuring/Reading/Recording frequency	Measuring continuously and Recording monthly Actually this parameter is continuously measured and daily recorded. If needed, the monitoring data can be presented using appropriate time interval.			
Calculation method (if applicable)	N/A			
QA/QC procedures	Calibration has been conducted to guarantee the accuracy and normal			

	functions of M3, according to relevant national or industrial standards by qualified institution; Sales receipts are used for cross-check.
Purpose of data	Used for baseline emission calculation
Additional comment	-

Data/Parameter	$EG_{\text{facility},y}$
Unit	MWh
Description	Net electricity supplied to the grid by the project
Measured/Calculated/Default	Calculated
Source of data	Calculation
Value(s) of monitored parameter	108,443.775
Monitoring equipment	N/A
Measuring/Reading/Recording frequency	-
Calculation method (if applicable)	$EG_{\text{facility},y} = EG_{\text{export},y} - EG_{\text{import},y} - EG_{\text{backupline},y}$
QA/QC procedures	-
Purpose of data	Used for baseline emission calculation
Additional comment	-

D.3. Implementation of sampling plan

>>

N/A

SECTION E. Calculation of emission reductions or GHG removals by sinks

E.1. Calculation of baseline emissions or baseline net GHG removals by sinks

>>

The monitoring data⁴ used for baseline emission reductions calculation are listed in the following tables:

Table 2 Electricity supplied to the Grid ($EG_{\text{export},y}$)(MWh)

Monitoring period	From	To	Meter readings (M1)	Data on the sales receipts	Data for ERs calculation
			A	B	C=Min(A,B)
15/09/2011~ 09/01/2012	15/09/2011	30/09/2011	15,227.575	15,227.575	10,155.200*
	01/10/2011	31/10/2011	29,243.500	29,243.500	27,969.425*
	01/11/2011	30/11/2011	27,969.700	27,969.700	27,969.700
	01/12/2011	31/12/2011	34,058.475	34,058.475	34,058.475
	01/01/2012	09/01/2012	8,470.000	8,470.000	8,470.000
Total			114,969.250	114,969.250	108,622.800

Note *: Due to a typo error in GSP MR, 10,155.2 was wrongly entered in both the meter readings and sales receipts for Sep. 2011 while 27,969.425 was wrongly entered in both meter readings and sales receipts for Oct. 2011. Although meter readings and sales receipts have been corrected as per the evidences in final version of MR/ER, the value in the GSP MR is lower hence is applied for ER calculation so as to result a lower ER. Such reduced emission reductions are not claimed and omitted by the PP.

⁴Due to the current monitoring period is less than six months, the monitoring data shall be presented weekly. Weekly monitoring data is detailed reported in ER calculation spreadsheet.

Table 3 Electricity imported via 110kV line ($EG_{import,y}$)(MWh)

Monitoring period	From	To	Meter readings (M1)	Data on the sales receipts	Data for ERs calculation
			D	E	F=Max(D,E)
15/09/2011~ 09/01/2012	15/09/2011	30/09/2011	10.450	10.450	18.150*
	01/10/2011	31/10/2011	54.450	54.450	54.450
	01/11/2011	30/11/2011	64.350	64.350	64.350
	01/12/2011	31/12/2011	14.850	14.850	14.850
	01/01/2012	09/01/2012	27.225	27.225	27.225
Total			171.325	171.325	179.025

Note*: Due to a typo error in GSP MR, 18.150 was wrongly entered in both the meter readings and sales receipts for Sep. 2011. Although meter readings and sales receipts have been corrected as per the evidences in final version of MR/ER, the value in the GSP MR is higher hence has been applied for ER calculation to result a lower ER. Such reduced emission reductions are not claimed and omitted by the PP.

 Table 4 Electricity imported via 10kV line ($EG_{backupline,y}$) (MWh)

Monitoring period	From	To	Meter readings (M3)	Data on the sales receipts	Data for ERs calculation
			G	H	I=Max(G,H)
15/09/2011~ 09/01/2012	15/09/2011	30/09/2011	0.000	0.000	0.000
	01/10/2011	31/10/2011	0.000	0.000	0.000
	01/11/2011	30/11/2011	0.000	0.000	0.000
	01/12/2011	31/12/2011	0.000	0.000	0.000
	01/01/2012	09/01/2012	0.000	0.000	0.000
Total			0.000	0.000	0.000

As per the monitoring plan, $EG_{facility,y}$ is calculated as:

$$\begin{aligned}
 EG_{facility,y} &= EG_{export,y} - EG_{import,y} - EG_{backupline,y} \\
 &= 108,622.800 - 179.025 - 0.000 \\
 &= 108,443.775 \text{ MWh}
 \end{aligned}$$

Then, BE_y is calculated as:

$$\begin{aligned}
 BE_y &= EG_{facility,y} \times EF_{Grid, CM, y} \\
 &= 108,443.775 \times 1.05485 \\
 &= 114,391 \text{ t CO}_2\text{e}
 \end{aligned}$$

E.2. Calculation of project emissions or actual net GHG removals by sinks

>>

As per ACM0002, project emissions are 0 for most renewable power generation project activities, including wind power project, i.e. $PE_y=0$

E.3. Calculation of leakage

>>

As per ACM0002, no leakage emissions are considered, i.e. $L_y=0$

**E.4. Summary of calculation of emission reductions or net anthropogenic GHG removals by sinks**

Time Period	Baseline emissions or baseline net GHG removals by sinks (tCO _{2e})	Project emissions or actual net GHG removals by sinks (tCO _{2e})	Leakage (tCO _{2e})	Emission reductions or net anthropogenic GHG removals by sinks (tCO _{2e})
Total	114,391	0	0	114,391

E.5. Comparison of actual emission reductions or net anthropogenic GHG removals by sinks with estimates in registered PDD

Item	Values estimated in ex-ante calculation of registered PDD	Actual values achieved during this monitoring period
Emission reductions or GHG removals by sinks(tCO_{2e})	137,174 ⁵	114,391

E.6. Remarks on difference from estimated value in registered PDD

>>

Compared with the estimated ERs during the same time period, the actual ERs are not increased.

History of the document

Version	Date	Nature of revision
02.0	EB 66 13 March 2012	Revision required to ensure consistency with the "Guidelines for completing the monitoring report form" (EB 66, Annex 20).
01	EB 54, Annex 34 28 May 2010	Initial adoption.
Decision Class: Regulatory Document Type: Form Business Function: Issuance		

⁵It is calculated as $427,936 \times 117/365 = 137,174$