



**Verified Carbon
Standard**

HUIZHOU LANDFILL GAS POWER GENERATION PHASE III AND IV PROJECT

Document Prepared by Goldchina Consultancy International Co., Ltd.

| | |
|----------------------|---|
| Project Title | Huizhou Landfill Gas Power Generation Phase III and IV Project |
| Version | 01 |
| Date of Issue | 16/05/2022 |
| Prepared By | Dr. Zhaoning Zheng Goldchina Consultancy International Co., Ltd. |
| Contact | Address: Room 230, Unit B, Building 2, Tangning One, No. 16 of Zhongguancun East Road, Haidian District, Beijing, China 100083 Telephone: (86) 18010121386 Fax: (8610) 6268 2682 Email: zzn@gcci-carbon.com |

CONTENTS

| | |
|--|-----------|
| 1 PROJECT DETAILS | 4 |
| 1.1 Summary Description of the Project | 4 |
| 1.2 Sectoral Scope and Project Type | 4 |
| 1.3 Project Eligibility | 5 |
| 1.4 Project Design | 5 |
| 1.5 Project Proponent | 5 |
| 1.6 Other Entities Involved in the Project | 5 |
| 1.7 Ownership | 6 |
| 1.8 Project Start Date | 6 |
| 1.9 Project Crediting Period | 6 |
| 1.10 Project Scale and Estimated GHG Emission Reductions or Removals | 6 |
| 1.11 Description of the Project Activity | 7 |
| 1.12 Project Location | 10 |
| 1.13 Conditions Prior to Project Initiation | 100 |
| 1.14 Compliance with Laws, Statutes and Other Regulatory Frameworks | 10 |
| 1.15 Participation under Other GHG Programs | 11 |
| 1.16 Other Forms of Credit | 11 |
| 1.17 Sustainable Development Contributions | 11 |
| 1.18 Additional Information Relevant to the Project | 12 |
| 2 SAFEGUARDS | 12 |
| 2.1 No Net Harm | 13 |
| 2.2 Local Stakeholder Consultation | 13 |
| 2.3 Environmental Impact | 14 |
| 2.4 Public Comments | 15 |
| 2.5 AFOLU-Specific Safeguards | 15 |
| 3 APPLICATION OF METHODOLOGY | 15 |
| 3.1 Title and Reference of Methodology | 15 |
| 3.2 Applicability of Methodology | 15 |
| 3.3 Project Boundary | 21 |

| | |
|---|------------|
| 3.4 Baseline Scenario | 253 |
| 3.5 Additionality | 254 |
| 3.6 Methodology Deviations | 264 |
| 4 QUANTIFICATION OF GHG EMISSION REDUCTIONS AND REMOVALS | 264 |
| 4.1 Baseline Emissions | 265 |
| 4.2 Project Emissions | 407 |
| 4.3 Leakage | 428 |
| 4.4 Net GHG Emission Reductions and Removals | 38 |
| 5 MONITORING | 39 |
| 5.1 Data and Parameters Available at Validation | 39 |
| 5.2 Data and Parameters Monitored | 49 |
| 5.3 Monitoring Plan | 616 |

1 PROJECT DETAILS

1.1 Summary Description of the Project

Huizhou Landfill Gas Power Generation Phase III and IV Project (hereafter referred to as the project) is invested and owned by Shenzhen PhasCon Technologies Co., Ltd. (hereafter referred to as the project owner). The project captures the landfill gas that would have been released to the atmosphere in the absence of the project and generates electricity with the landfill gas (LFG). The electricity is supplied to the China Southern Power Grid (CSPG) to replace the electricity generated from coal-fired power plants of CSPG.

Huizhou landfill site is located in Gongmaliandong, Huicheng District, Huizhou City, Guangdong Province, China. The landfill site started operation in 2000 with an operational lifespan of 25 years. Now the landfill handles an average of 2,000 tonnes Municipal Solid Waste (MSW) per day which is mainly from the Huizhou City.

The purpose of the project is to use LFG, which consists mainly of methane, for electricity generation. It includes LFG collection system, LFG pre-treatment system, electricity generation system and flare system. The project started to construct on 16/07/2020. The total installed capacity of the project is 9.42MW with two phases. Phase III is 3.5MW consisting of 5 sets of 700kW generator, which was operated since 14/12/2020. Phase IV is 5.92MW consisting of 16 sets of 370kW generator, which was operated since 01/03/2021. LFG collected is used for electricity generation with internal combustion generators to generate about 377,699MWh supplying to CSPG during the first 7 years crediting period. An annual estimated 53,957MWh electricity will be delivered to the CSPG by the Project Activity. The expected average annual emission reductions are 293,065 tCO₂e and the total emission reductions are 2,051,457 tCO₂e during the 7-year crediting period considering the 28 of GWP_{CH4}¹.

Scenario existing prior to the implementation of the project (the same as baseline scenario):

LFG from Huizhou landfill site is emitted to the atmosphere directly. Equivalent electricity generated by the project is provided by CSPG, which is dominated by coal-fired power stations.

1.2 Sectoral Scope and Project Type

Sectoral scope 1: energy industries (renewable-/non-renewable sources), and sectoral scope 13: Waste handling and disposal.

¹ As per VCS Standard V4.1, for GHG emission reductions occurring on or before 31 December 2020, all ex-ante estimates and ex-post calculations may be converted to CO₂e using either the GWP values from the IPCC Fourth Assessment Report (AR4) or those from AR5. So the GWP values from AR5 was applied for the project.

Project Type: Waste handling and disposal

The project is not a grouped project.

1.3 Project Eligibility

The scope of the VCS Program includes six Kyoto Protocol greenhouse gases. The project is a landfill gas (LFG) power generation project, utilizing LFG, which consists mainly of methane, for electricity generation, which is eligible under the scope of the VCS program.

1.4 Project Design

- The project includes a single location or installation only
- The project includes multiple locations or project activity instances, but is not being developed as a grouped project
- The project is a grouped project

Eligibility Criteria

Not applicable.

1.5 Project Proponent

| | |
|--------------------------|--|
| Organization name | Shenzhen PhasCon Technologies Co., Ltd. |
| Contact person | Tony You |
| Title | Vice General Manager |
| Address | Room 1210, Satellite Building, No. 61, High-tech Nanjiu Road, Nanshan District, Shenzhen, China 518000 |
| Telephone | (86)-13538080705 |
| Email | Tonyyou@iphascon.com |

1.6 Other Entities Involved in the Project

| | |
|----------------------------|---|
| Organization name | Goldchina Consultancy International Co., Ltd. |
| Role in the project | Consultancy |

| | |
|-----------------------|---|
| Contact person | Dr. Zheng Zhaoning |
| Title | Technical director |
| Address | Room 230, Unit B, Building 2, Tangning One, No. 16 of Zhongguancun East Road, Haidian District, Beijing, China 100083 |
| Telephone | (86) 18010121386 |
| Email | zzn@gcci-carbon.com |

1.7 Ownership

The project owner is Shenzhen PhasCon Technologies Co., Ltd.. The approval of Feasibility Study Report (FSR) and Environmental impact Assessment (EIA), and the business license of the project owner are the evidence for legislative right. Besides, the purchasing power agreement are the evidence for the ownership of the plant equipment and power generating. Shenzhen PhasCon Technologies Co., Ltd. is responsible for the acquisition of approvals, construction, and operation of the project.

1.8 Project Start Date

14/12/2020 (commercial operation started date).

1.9 Project Crediting Period

7 years *3 renewable crediting period is adopted by the project activity.

The first 7 years VCS project crediting period started on 14/12/2020 and will be expired on 13/12/2027 (the start and end dates included).

1.10 Project Scale and Estimated GHG Emission Reductions or Removals

The estimated annual GHG emission reductions/removals of the project are:

- <20,000 tCO₂e/year
- 20,000 – 100,000 tCO₂e/year
- 100,001 – 1,000,000 tCO₂e/year
- >1,000,000 tCO₂e/year

Project Scale

| | |
|---------------|---|
| Project | √ |
| Large project | √ |

删除[作者]: √

| Year | Estimated GHG emission reductions or removals (tCO ₂ e) |
|--|--|
| 14/12/2020 - 31/12/2020 | 15,434 |
| 2021 | 333,083 |
| 2022 | 344,002 |
| 2023 | 349,151 |
| 2024 | 350,284 |
| 2025 | 272,324 |
| 2026 | 217,522 |
| 01/01/2027 - 13/12/2027 | 169,656 |
| Total estimated ERs | 2,051,457 |
| Total number of crediting years | 7 |
| Average annual ERs | 293,065 |

1.11 Description of the Project Activity

GHG emission reductions will be achieved through combustion of the recovered LFG by gas engines, which would be otherwise emitted to the atmosphere, and the generation of electricity from the LFG is exported to CSPG to replace equivalent amount of electricity from those fossil fuel-fired power plants connected to CSPG.

The project includes an LFG collection system, an LFG pre-treatment system, an electricity generation plant, and grid connection system.

LFG collection system

The landfill gas collecting system is a gas pipeline network, consisting of gas collecting wells, gas collecting pipelines, and gas collection blower. LFG is extracted by gas collection blower and transported by pipeline from gas collection wells.

LFG pre-treatment system

Prior to electricity generation, LFG must be pre-treated to remove its impurities and moisture, etc., to prevent corrosion in the generators. According to the EIA, the pre-treatment system consists of six types of equipment:

- 1) Impurity Filter to remove the impurity in LFG primarily;
- 2) Condenser to remove the water in LFG;
- 3) Gas-liquid Separator to remove the liquid in LFG further;
- 4) Fan Blower to boost the LFG;
- 5) Heat Exchanger to cool down the gas;
- 6) Advanced Impurity Filter to remove the impurity thoroughly.

The LFG pre-treatment procedure and the main equipment are shown as the following chart:

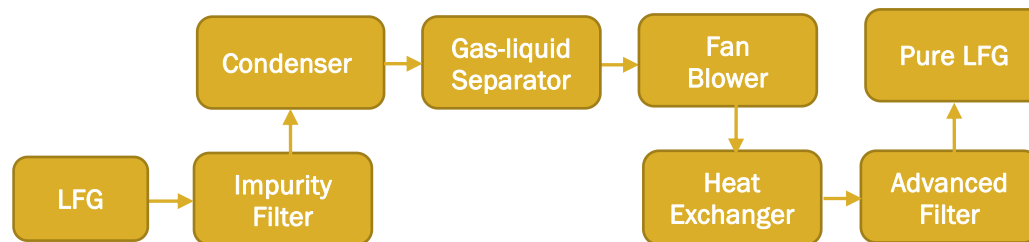

Figure 1.1 The flow chart of the LFG pre-treatment system

Power generation and grid connection system

A power plant is installed in order to generate electricity with the LFG captured. It adopts internal combustion engine generating sets. The number of engines to be installed would depend on the amount of LFG collected, but project owner installed in two phases a total capacity of 9.42MW. The electricity generated using LFG, except small portion for on-site usage, is exported to CSPG.

This is a well-known and high reliable technology for biogas utilization. Furthermore, internal combustion engine generating sets have modular design and are available in many different sizes permitting the installation of power plant step by step as the LFG flow increases. High performance and reliability are guaranteed for the equipment.

The detailed information about the technology of the project is shown in the table below.

Table 1.1 Key technical parameters of internal combustion engine generating set

| Type | Gas-fired Engine and generator | |
|----------------|--------------------------------|------------|
| Model | 700GFZ--RZ-TEM2-4 | 370GF1-1RZ |
| Rated Voltage | 400V | 400V |
| Rated capacity | 700kW | 370kW |
| Lifetime | 20 years | 20 years |

In the project activity, the landfill gas is extracted by the blowers through the vertical gas wells from well-sealed landfill, and delivered for flaring by a closed flare, or combusted by gas generator as energy, the landfill gas is pre-treated by water/gas separation in a knock tank, as shown in figure 1.2. The main state-of-art technologies to be adopted in the project including:

1. Landfill sealing with soil and green plants, as well as the rain waterspout drainage system, so as to keep the whole landfill well sealed;
2. Landfill gas vertical well constructed with PhasCon cone-sinking technology;
3. Landfill gas horizontal piping with sink-well drainage technology;
4. Gas/water separating and LFG drying technology with knock-off drum and cooling system;
5. Blower station with multi-stage centrifuge pumps for LFG extraction from the landfill;
6. Methane fraction and oxygen fraction online monitoring and safety control technology;
7. LFG purifying treatment technology and LFG power generation with gas generators.

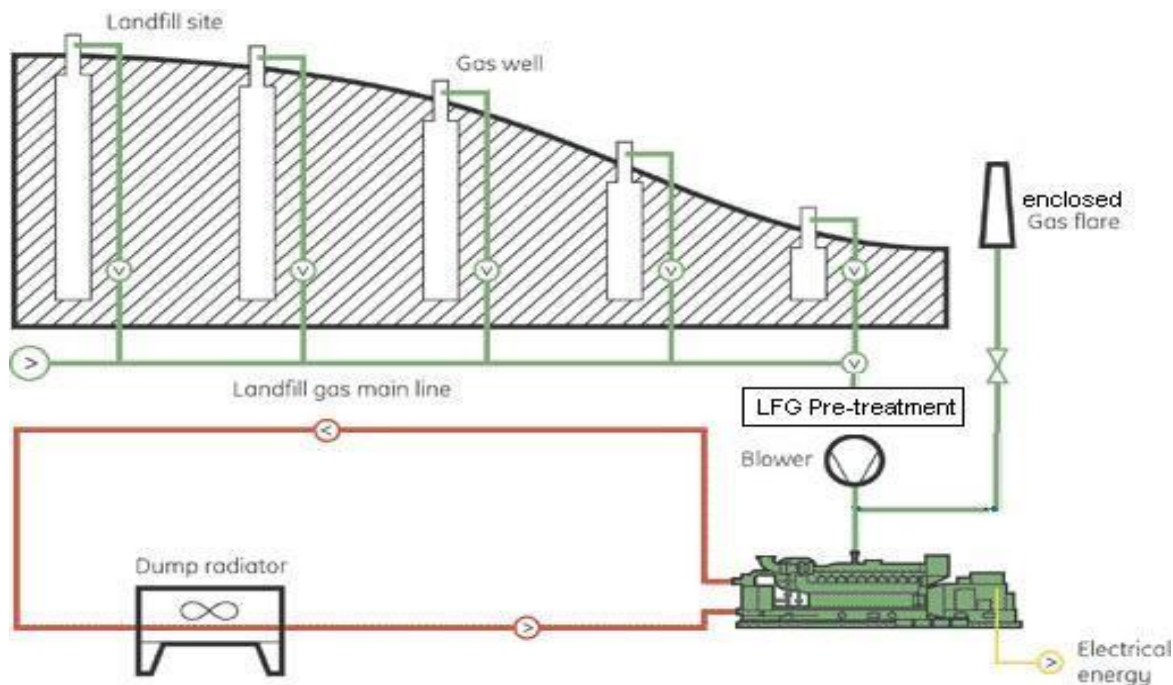

Figure 1.2 Configuration of LFG collection and utilization in power generation

1.12 Project Location

The project is located in Gongmaliandong, Huicheng district, Huizhou city, Guangdong Province, China. The project's geographical coordinates are longitude 114o20'52.62" E and latitude 23o06'32.87" N. The physical locations are shown in Figures below.

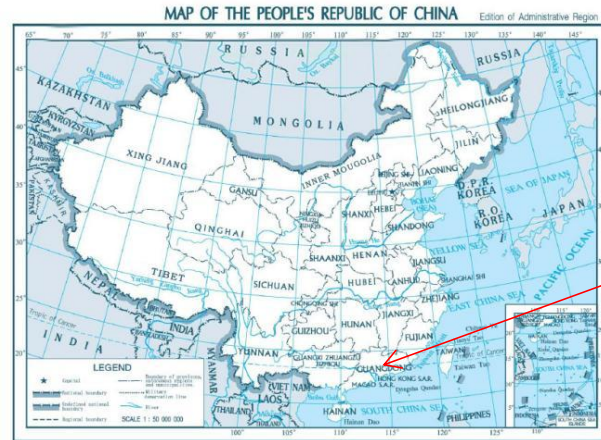

Figure1.3. Location of Guangdong Province in China



Figure 1.4. Huizhou City in Guangdong



Figure 1.5. Location of Project Activity at Huizhou

1.13 Conditions Prior to Project Initiation

The baseline scenarios are the same as the conditions existing prior to the project initiation. The details are showed in the Section 3.4.

1.14 Compliance with Laws, Statutes and Other Regulatory Frameworks

The project complies with all Chinese relevant laws and regulations. Mainly include:

1. Renewable Energy Law of the People's Republic of China;
2. Catalogue for the Guidance of Industrial Structure Adjustment (2011 version);
3. National Action plan for the collection and Utilization of municipal landfill gas.

The project obtained the approval letters from local governmental authorities: Development and Reform Commission, as well as Environment Protection Bureau(EPB). These two approvals well demonstrate that local governments permit the construction of the project. Hence, the project is in compliance with laws, status and other regulatory frameworks.

删除[作者]: The project is in the field of waste handling and disposal and meets the relevant provision of the law of the People's Republic of China on the Prevention and Control of Environmental Pollution by Solid Waste. The generation of power exported to CSPG will meet the requirement of national laws and regulations

1.15 Participation under Other GHG Programs

1.15.1 Projects Registered (or seeking registration) under Other GHG Program(s)

The project has not been registered/or is seeking registration under other GHG Program(s).

1.15.2 Projects Rejected by Other GHG Programs

The project has not been rejected by other GHG programs.

1.16 Other Forms of Credit

1.16.1 Emissions Trading Programs and Other Binding Limits

Does the project reduce GHG emissions from activities that are included in an emissions trading program or any other mechanism that includes GHG allowance trading?

Yes No

1.16.2 Other Forms of Environmental Credit

Has the project sought or received another form of GHG-related credit, including renewable energy certificates?

Yes No

1.17 Sustainable Development Contributions

The project will contribute to sustainable development in the following sides:

Landfill safety

The uncontrolled release of landfill gas can lead to risks of flammable and explosive threat on the landfill site, those kinds of negative impact and risks could be greatly reduced by

implementation of Project Activity. It is known that if methane concentration in the air is in the range of 5-15% in volume within the confined space of a building, the risk of explosion is very high. With the project, a modern gas extraction system has been installed to ensure the effective collection of LFG, and thus minimize the risk of landfill explosions.

Odour reduction

Odour from landfill negatively impacts on residents around the landfill. Implementation of the project will reduce odour through LFG collection and will thus mitigate the impact of landfill odour on people's daily lives.

Energy potential

The project makes use of LFG to generate electricity, which supplements the energy supply of Huizhou city.

Provide employment

The project was designed and technically supported by experts. Temporary job opportunities were created during the construction period and 20 permanent jobs during the operation time. It also can train more professional technicians in LFG recovery and power generation in China.

As a whole, the project contributed to the sustainable development, not only by mitigating global warming, but also increasing the availability of electricity from renewable sources. It also minimized the explosion risk at the landfill site and increased job availability through the management, operation and maintenance of the LFG capture system and the power units.

1.18 Additional Information Relevant to the Project

Leakage Management

No special leakage management.

Commercially Sensitive Information

No commercially sensitive information has been excluded from the public version of the project description.

Further Information

No further information.

2 SAFEGUARDS

2.1 No Net Harm

There is no net harm. For the phase III project, the Environmental Impact Assessment (EIA) Report for the project was compiled by Guangzhou Fanyu Environmental Science Research Institute Ltd. Combined with the EIA report, the influences of the project on the environment are summarized. The EIA Report for the Project has been approved by the Environmental Protection Bureau of Huicheng District on 08/06/2017, with approval No. "Huicheng Huanjiang [2017] No.75". For the phase IV project, the Environmental Impact Assessment (EIA) Report for the project was compiled by Chongqing Darun Environmental Science Research Institute Ltd, which is a grade A environment impact assessment entity certified by the Ministry of Ecology and Environment, China. Combined with the EIA report, the influences of the project on the environment are summarized. The EIA Report for the Project has been approved by the Environmental Protection Bureau of Huicheng District on 31/12/2020, with approval No. "Huicheng Huanjiang [2020] No.164". According to the approval comments of the EIA Report by the Environmental Protection Bureau of Huicheng district, Huizhou city, the environmental impacts likely to be caused by the project are considered insignificant and conforming to the laws and regulations; therefore, there is no net harm.

2.2 Local Stakeholder Consultation

A public consultation on survey of stakeholder comments is mainly in the form of handing out questionnaires together with interview was conducted and introduced by the project owner. The survey focuses on the farmers from Gongliancun village who live around the landfill area. The following questions are from the questionnaires:

1. What do you know about the LFG power station?
2. What is your attitude to the construction of this LFG power station?
3. Do you think the implementation of the project will cause positive effect on living of local residents?
4. Do you think the implementation of the project will cause negative effect?
5. What can the project owner do to reduce the negative effect?
6. As a whole, what is your opinion on this LFG power station to the living of local residents??

The project is away from the residence, so, only 12 families live around the project and the landfill site. Each family was distributed a questionnaire. In total 12 out of 12 questionnaires were returned with a 100% response rate. The survey shows the stakeholders believe that the project will have positive impacts on the local ecology and employment. All stakeholders expressed their support to the project and were pleased with the development of the project, and no negative comments have been received. The project would actually facilitate the development of the local economy and increase the income of local residents.

During project implementation phase, there is a public comments collection and feedback book for the power plant. The local stakeholders can leave their opinions, comments and concerns on the project and contact information in the public comments collection and feedback book at any time. The project owner will contact the local stakeholder to give feedback within one week. So far, no public comments about potential negative impacts during project implementation have been received by the project owner.

2.3 Environmental Impact

The Environmental Impact Assessment (EIA) Reports for the the phase III and phase IV projects were compiled by Guangzhou Fanyu Environmental Science Research Institute Ltd. and Chongqing Darun Environmental Science Research Institute Ltd. respectively. Combined with the EIA reports, the influences of the project on the environment are summarized.

According to the Environmental Impact Assessment, environmental impacts possibly caused by the project and protection measures adopted by the project owner are analysed as follows:

Water Quality

The amount of wastewater which is produced by the project is very small. The condensate water during the process of landfill gas collection will be treated by the landfill leachate treatment system. The domestic wastewater from onsite employees will be treated in the septic tank and then treated by the landfill leachate treatment system.

Air Quality

This project uses LFG which is collected from Huizhou landfill site to generate electricity, and it avoids uncontrolled releasing of LFG. Therefore, it reduces greenhouse gas and effluvium emitting to air, and mitigates the possible danger of fire or explosion.

The emission amount of NO_x, SO₂ and NH₃ for this project is less than the national emission standards, that is because prior to electricity generation, LFG has been pre-treated to remove its impurities and moisture. After that, LFG is sent to gas-fired engines. And the exhaust gas would be emitted to atmosphere which is far away from sensitive targets. Therefore, the emission of exhaust gas has little impact on surrounding environment.

Noise

The project is surrounded by landfill site and mountains, the only building which is next to the project is Huizhou landfill site office building. The EIA has said that under the influence of distance attenuation, air absorption and trees blocking, the noise of the project has no impact on surrounding residential areas.

Solid Waste

This project produces small amounts of solid waste. The general industrial solid waste is dust. All solid waste will be sent to the landfill site, which could not only ensure the safety of disposal, but also has little impact on surrounding environment.

As a whole, the project was not considered that it would bring out negative environmental impacts. On the contrary, this project will promote local environment by reducing emission of greenhouse gas.

2.4 Public Comments

The Project will be listed on the Verra website for public comment.

2.5 AFOLU-Specific Safeguards

The project is not an AFOLU project.

3 APPLICATION OF METHODOLOGY

3.1 Title and Reference of Methodology

Title: Flaring or use of landfill gas -- Version 19.0

Reference: <https://cdm.unfccc.int/methodologies/PAmethodologies/approved>

The methodology also refers to the latest approved versions of the following tools:

“Combined tool to identify the baseline scenario and demonstrate additionality” (Version 07.0);

“Baseline, project and/or leakage emissions from electricity consumption and monitoring of electricity generation” (Version 03.0);

“Emissions from solid waste disposal sites” (Version 08.0);

“Tool to calculate the emission factor for an electricity system” (Version 07.0);

“Tool to determine the mass flow of a greenhouse gas in a gaseous stream”(Version 03.0);

“Positive lists of technologies” (Version 04.0).

3.2 Applicability of Methodology

The selected methodology (ACM0001, version 19.0) is appropriate to LFG project activities, where the baseline scenario is the atmospheric release of the LFG, and that all or part of the electricity exported to the grid is the electricity generation in existing and/or new grid-connected power plants. In this case, the LFG is released to atmosphere prior to

the implementation of the project, electricity generated by the project is exported to China Southern Power Grid (CSPG).

According to the EIA of the project, it fulfills the following applicability conditions of the methodology ACM0001:

| Applicability conditions | Justifications |
|--|--|
| (a) Install a new LFG capture system in an existing or new (Greenfield) SWDS where no LFG capture system was or would have been installed prior to the implementation of the project activity; or | Applicable. The project involves the installation of a new LFG capture system in an existing SWDS. |
| (b) Make an investment into an existing LFG capture system to increase the recovery rate or change the use of the captured LFG, provided that: <ul style="list-style-type: none"> (i) The captured LFG was vented or flared and not used prior to implementation of the project activity; and (ii) In the case an existing active LFG capture system for which the amount of LFG cannot be collected separately from the project system after the implementation of the project activity and its efficiency is not impacted on by the project system: historical data on the amount LFG capture and flared is available; | Not applicable. There wasn't an LFG capture system prior to the implement of the project. |
| (c) Flare the LFG and/or use the captured LFG in any (combination) of the following ways: <ul style="list-style-type: none"> (i) Generation electricity; (ii) Generation heat in a boiler, air or kiln or glass melting furnace; and/or (iii) Supplying the LFG to consumers through a natural gas distribution network; (iv) Supplying compressed/liquefied LFG to consumers using trucks; (v) Supplying the LFG to consumers through a dedicated pipeline; | Applicable. The project uses the captured LFG to generate electricity, which corresponds to point (i). |

| | |
|---|---|
| <p>(d) Do not reduce the amount of organic waste that would be recycled in the absence of the project.</p> | <p>The implementation of the project does not reduce the amount of organic waste that would be recycled in the absence of the project. All the solid waste is disposed in the Huizhou landfill site.</p> |
| <p>The methodology is only applicable if the application of the procedure to identify the baseline scenario confirms that the most plausible baseline scenario is:</p> <p>(a) Atmospheric release of the LFG or captured of LFG and destruction through flaring to comply with regulations or contractual requirements, to address safety and odour concerns, or for other reasons; and</p> <p>(b) In the case that the LFG is used in the project activity for generation electricity and/or generating heat in a boiler, air heater, glass melting furnace or kiln:</p> <p>(i) For electricity generation: that electricity would be generated in the grid or in captive fossil fuel fired power plants; and/or</p> <p>(ii) For heat generation: that heat would be generated using fossil fuels in equipment located within the project boundary</p> <p>(c) In the case of LFG supplied to the end-user(s) through natural gas distribution network, trucks or the dedicated pipeline, the baseline scenario is assumed to be displacement of the natural gas.</p> <p>(d) In the case of LFG from a Greenfield SWDS, the identified baseline scenario is atmospheric release of the LFG or captured of LFG in a managed SWDS and destruction through flaring to comply with regulations or contractual requirements, to address safety and odour concerns, or for other reasons.</p> | <p>The most plausible baseline scenario of the project is:</p> <p>(1) LFG from Huizhou landfill site is emitted to the atmosphere directly.</p> <p>(2) Equivalent electricity generated by the project is supplied by the China Southern Power Grid (CSPG).</p> |

| | |
|---|------------------------|
| <p>The methodology is not applicable:</p> <p>(a) In combination with other approved methodologies. For instance, ACM0001 cannot be used to claim emission reductions for the displacement of fossil fuels in a kiln or glass melting furnace, where the purpose of the CDM project activity is to implement energy efficiency measures at a kiln or glass melting furnace;</p> <p>(b) If the management of the SWDS in the project activity is deliberately changed during the crediting in order to increase methane generation compared to the situation prior to the implementation of the project activity.</p> | <p>Not applicable.</p> |
|---|------------------------|

Regarding to tool— “Baseline, project and/or leakage emissions from electricity consumption and monitoring of electricity generation” (Version 03.0):

| Applicable conditions | Justifications |
|---|---|
| <p>a. If emissions are calculated for electricity consumption, the tool is only applicable if one out of the following three scenarios applied to the sources of the electricity consumption:</p> <p>b. Scenario A: Electricity consumption from the grid. The electricity is purchased from the grid only, and either no captive power plant(s) is/are installed at the site of electricity consumption or, if any captive power plant exists on site, it is either not operating or it is not physically able to provide electricity to the electricity consume;</p> <p>c. Scenario B: Electricity consumption from (an) off-grid fossil fuel fired captive power</p> | <p>Scenario A is applicable for the project. The project purchases electricity from the grid during the operation. There is no captive power plant(s) at the site of the project.</p> |

| | |
|--|------------------------|
| <p>plant(s). One or more fossil fuel fired captive power plants are installed at the site of the electricity consume and supply the consumer with electricity. The captive power plant(s) is/are not connected to the electricity grid; or</p> <p>d. Scenario C: Electricity consumption from the grid and (a) fossil fuel fired captive power plant(s). One or more fossil fuel fired captive power plants operate at the site of the electricity consumer. The captive power plant(s) can provide electricity consumer. The captive power plant(s) is/are also connected to the electricity grid. Hence, the electricity consumer can be provided with electricity from the captive power plant(s) and the grid.</p> | |
| <p>Scenario A is applicable for the project. The project purchases electricity from the grid during the operation. There is no captive power plant(s) at the site of the project.</p> | <p>Not applicable.</p> |

Regarding to tool— “Tool to calculate the emission factor for an electricity system” (Version 07.0):

| Applicable conditions | Justifications |
|---|---|
| <p>This tool may be applied to estimate the OM, BM and/or CM when calculating baseline emissions for a project activity that substitutes grid electricity that is where a project activity supplies electricity to a grid or a project activity that results in savings of electricity that would have been provided by the grid (e.g. demand-side energy efficiency projects).</p> | <p>Applicable. This tool is applied to estimate the OM, BM and/or CM.</p> |

| | |
|---|---|
| <p>Under this tool, the emission factor for the project electricity system can be calculated either for grid power plants only or, as an option, can include off-grid power plants. In the latter case, two sub-options under the step 2 of the tool are available to the project participants, i.e. option IIa and option IIb. If option IIa is chosen, the conditions specified in “Appendix 1: Procedures related to off-grid power generation” should be met. Namely, the total capacity of off-grid power plants (in MW) should be at least 10 per cent of the total capacity of grid power plants in the electricity system; or the total electricity generation by off-grid power plants (in MWh) should be at least 10 per cent of the total electricity generation by grid power plants in the electricity system; and that factors which negatively affect the reliability and stability of the grid are primarily due to constraints in generation and not to other aspects such as transmission capacity.</p> | <p>Applicable. The emission factor for the project electricity system is calculated for grid power plants only.</p> |
| <p>In case of CDM projects the tool is not applicable if the project electricity system is located partially or totally in an Annex I country.</p> | <p>Not applicable. The project electricity system is located in China.</p> |
| <p>Under this tool, the value applied to the CO₂ emission factor of biofuel is zero.</p> | <p>Not applicable.</p> |

Regarding to tool– “Tool to determine the mass flow of a greenhouse gas in a gaseous stream” (Version 03.0):

| Applicable conditions | Justifications |
|-----------------------|----------------|
|-----------------------|----------------|

| | |
|---|--|
| <p>Typical applications of this tool are methodologies where the flow and composition of residual or flared gases or exhaust gases are measured for the determination of baseline or project emissions.</p> | <p>Applicable. This tool is applied to determination of baseline emissions by measuring the combusted LFG.</p> |
| <p>Methodologies where CO₂ is the particular and only gas of interest should continue to adopt material balances as the means of flow determination and may not adopt this tool as material balances are the cost effective way of monitoring flow of CO₂.</p> | <p>Not applicable.</p> |
| <p>The underlying methodology should specify:</p> <ul style="list-style-type: none"> (a) The gaseous stream the tool should be applied to; (b) For which greenhouse gases the mass flow should be determined; (c) In which time intervals the flow of the gaseous stream should be measured: and (d) Situations where the simplification offered for calculating the molecular mass of the gaseous stream (equations (3) or (17)) is not valid (such as the gaseous stream is predominantly composed of a gas other than N₂) | <p>Applicable. The gaseous stream determined the baseline emissions is LFG which mainly contains fraction of CH₄, which corresponds to point (a) and (b).</p> <p>LFG combusted by the engines is measured continuously by a flow meter and recorded hourly, which corresponds to point (c).</p> <p>Point (d) is not applicable.</p> |

Regarding to tool— “Positive lists of technologies” (Version 04.0):

| Applicable conditions | Justifications |
|--|---|
| <p>The use of this methodological tool is not mandatory for the project participants of a CDM project activity or CDM POA for demonstrating their additionality.</p> | <p>Applicable.</p> |
| <p>This methodological tool shall be applied in conjunction with a small-scale or large-scale methodology which refers to this tool.</p> | <p>Applicable. This tool is applied in conjunction with large-scale methodology ACM0001 (version 19.0).</p> |

Regarding to tool– “Emissions from solid waste disposal sites” (Version 08.0):

| | |
|--|--|
| <p>(a) Application A: The CDM project activity mitigates methane emissions from a specific existing SWDS. Methane emissions are mitigated by capturing and flaring or combusting the methane (e.g. "ACM0001: Flaring or use of landfill gas). The methane is generated from waste disposed in the past, including prior to the start of the CDM project activity. In these cases, the tool is only applied for an ex ante estimation of emissions in the project design document (CDM-PDD). The emissions will then be monitored during the crediting period using the applicable approaches in the relevant methodologies (e. g. measuring the amount of methane captured from the SWDS).</p> | <p>Applicable. The project collects the methane from the Huizhou landfill site and use it to generate the electricity.</p> |
| <p>(b) Application B: The CDM project activity avoids or involves the disposal of waste at a SWDS. An example of this application of the tool is ACM0022, in which municipal solid waste (MSW) is treated with an alternative option, such as composting or anaerobic digestion, and is then prevented from being disposed of in a SWDS. The methane is generated from waste disposed or avoided from disposal during the crediting period. In these cases, the tool can be applied for both ex ante and ex post estimation of emissions. These project activities may apply the simplified approach detailed in 0 when calculating baseline emissions.</p> | <p>Not applicable.</p> |

3.3 Project Boundary

The project boundary is the site of the project activity where the gas is captured and destroyed.

The Project Activity boundary consists of the whole LFG related system, including LFG collection, and LFG power generation system, auxiliary equipment, etc. The project baseline boundary includes all the facilities in the landfill except the LFG system, as well as all grid-connected power plants in China Southern Power Grid which provides the electricity to the landfill. China Southern

Power Grid consists of five provinces, i.e. Guangdong, Guangxi, Yunnan, Guizhou and Hainan. The project boundary is shown in figure 3.1.

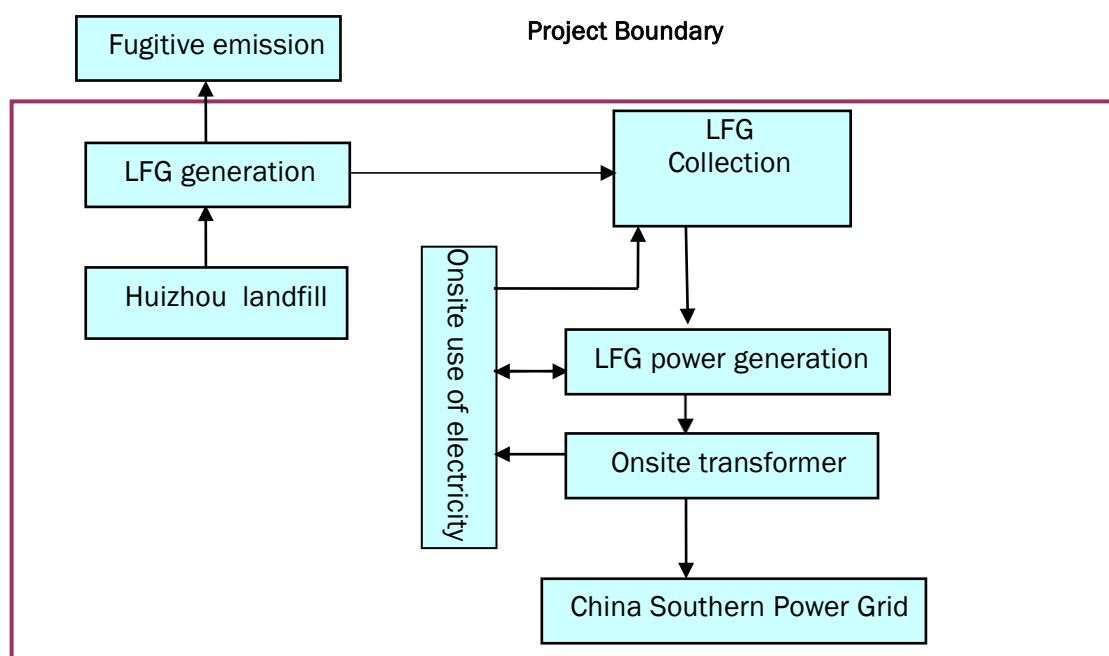

Figure 3.1 the Diagram of Project Boundary

Table 3.1 Summary of greenhouse gases and sources included in and excluded from the project boundary

| Source | Gas | Included? | Justification/Explanation |
|---------------------------|------------------|-----------|--|
| Baseline | CO ₂ | No | CO ₂ emissions from the decomposition of organic waste are not accounted since the CO ₂ is also released under the project activity. |
| | CH ₄ | Yes | The major source of emissions in the baseline. |
| | N ₂ O | No | N ₂ O emissions are small compared to CH ₄ emissions from landfills. Exclusion of this gas is conservative. |
| | Other | - | |
| Emission from electricity | CO ₂ | Yes | The major source of emissions in the |

| Source | Gas | Included? | Justification/Explanation | |
|------------|---|------------------|--|--|
| generation | | | baseline. | |
| | CH ₄ | No | Excluded for simplification, this is conservative. | |
| | N ₂ O | No | Excluded for simplification, this is conservative. | |
| | Other | - | | |
| Project | Emissions from fossil fuel consumption for purposes other than electricity generation or transportation due to the project activity | CO ₂ | No | Excluded because there is no fossil fuel consumption. |
| | | CH ₄ | No | Excluded because there is no fossil fuel consumption. |
| | | N ₂ O | No | Excluded because there is no fossil fuel consumption. |
| | | Other | - | |
| | Emissions from electricity consumption due to the project activity | CO ₂ | Yes | Main emission source. |
| | | CH ₄ | No | Excluded for simplification. This emission source is very small compared to CO ₂ emissions. |
| | | N ₂ O | No | Excluded for simplification. This emission source is very small compared to CO ₂ emissions. |
| | | Other | - | |

Table 3.2. The geographic coordinates of the Huizhou LFG project.

| Landfill | Location | Longitude | Latitude |
|------------------|--|-----------------|----------------|
| Huizhou Landfill | Gongmaliandong, Huicheng District, Huizhou City, Guangdong Province, China | 114°20'52.62" E | 23°06'32.87" N |

3.4 Baseline Scenario

According to the section 5.3.1 of the methodology ACM0001, the project chooses simplified procedures to identify the baseline scenario.

The LFG from Huizhou landfill site is vented to the atmosphere prior the implementation of the project for safety concerns, and the majority electricity generated by the LFG will be exported to the China Southern Power Grid (CSPG), and a little of which is consumed by the project.

Therefore, the baseline scenario is:

LFG from Huizhou landfill site is emitted to the atmosphere directly.

Equivalent electricity generated by the project is supplied by the CSPG, which is dominated by fossil fuel-based power plants.

3.5 Additionality

According to the section 5.3.1 of the methodology ACM0001, the project chooses simplified procedures to demonstrate additionality. Tool 32 (Positive lists of technologies) is used to demonstrate additionality.

| Requirements of tool 32 (Positive lists of technologies) | The project |
|---|--|
| <p>5.1 Waste handling and disposal</p> <p>5.1.1 Landfill gas recovery and its gainful use The project activities and PoAs at new or existing landfills (greenfield or brownfield) are deemed automatically additional if it is demonstrated that prior to the implementation of the project activities and PoAs the LFG was only vented and or flared (in the case of brownfield projects) or would have been only vented and/or flared (in the case of greenfield projects) but not utilized for energy generation, and that under the project activities and PoAs any of the following conditions are met:</p> <p>(a) The LFG is used to generate electricity in one or several power plants with a total nameplate capacity that equals or is below 10 MW;</p> <p>(b) The LFG is used to generate heat for</p> | <p>Applicable.</p> <p>The LFG from Huizhou landfill site is vented to the atmosphere prior the implementation of the project for safety concerns.</p> <p>Total nameplate capacity of the project is 9.42MW, which is below 10MW.</p> |

| | |
|---|--|
| internal or external consumption; (c) The LFG is flared. | |
|---|--|

Conclusion: the project is automatically additional.

3.6 Methodology Deviations

There is no methodology deviation.

4 QUANTIFICATION OF GHG EMISSION REDUCTIONS AND REMOVALS

4.1 Baseline Emissions

The project utilizes the LFG for generation to substitute the equivalent electricity supplied by the grid, resulting in CH₄ and CO₂ emissions, which will be calculated as follows according to the methodology ACM0001(version 19.0):

$$BE_y = BE_{CH_4,y} + BE_{EC,y} + BE_{HG,y} + BE_{NG,y} \quad \text{Equation (1)}$$

Where:

BE_y = Baseline emissions in year y (t CO₂e/yr)

$BE_{CH_4,y}$ = Baseline emissions of methane from the SWDS in year y (t CO₂e/yr)

$BE_{EC,y}$ = Baseline emissions associated with electricity generation in year y
(t CO₂/yr)

$BE_{HG,y}$ = Baseline emissions associated with heat generation in year y (t CO₂/yr)

$BE_{NG,y}$ = Baseline emissions associated with natural gas use in year y (t CO₂/yr)

The project doesn't involve heat and natural gas. $BE_{HG,y}=0, BE_{NG,y}=0$. Therefore:

$$BE_y = BE_{CH_4,y} + BE_{EC,y} \quad \text{Equation (2)}$$

Step A: Baseline emissions of methane from the SWDS ($BE_{CH_4,y}$)

$$BE_{CH_4} = \left((1 - OX_{top_layer}) \times F_{CH_4,PJ,y} - F_{CH,BL,y} \right) \times GWP_{CH_4} \quad \text{Equation (3)}$$

Where:

- $BE_{CH_4,y}$ = Baseline emissions of methane from the SWDS in year y (t CO₂e/yr)
- OX_{top_layer} = Fraction of methane in the LFG that would be oxidized in the top layer of the SWDS in the baseline (dimensionless)
- $F_{CH_4,PJ,y}$ = Amount of methane in the LFG which is flared and/or used in the project activity in year y (t CH₄/yr)
- $F_{CH_4,BL,y}$ = Amount of methane in the LFG that would be flared in the baseline in year y (t CH₄/yr)
- GWP_{CH_4} = Global warming potential of CH₄ (t CO₂e/t CH₄)

Step A1: Ex post determination of $F_{CH_4,PJ,y}$

During the crediting period, $F_{CH_4,PJ,y}$ is determined as the sum of the quantities of methane flared and used in power plant(s), boiler(s), air heater(s), glass melting furnace(s), kiln(s) and natural gas distribution, as follows:

$$F_{CH_4,PJ,y} = F_{CH_4,flared,y} + F_{CH_4,EL,y} + F_{CH_4,HG,y} + F_{CH_4,NG,y} \quad \text{Equation (4)}$$

Where:

- $F_{CH_4,PJ,y}$ = Amount of methane in the LFG which is flared and/or used in the project activity in year y (t CH₄/yr)
- $F_{CH_4,flared,y}$ = Amount of methane in the LFG which is destroyed by flaring in year y (t CH₄/yr)
- $F_{CH_4,EL,y}$ = Amount of methane in the LFG which is used for electricity generation in year y (t CH₄/yr)

$F_{CH_4, HG, y}$ = Amount of methane in the LFG which is used for heat generation in year y (t CH₄/yr)

$F_{CH_4, NG, y}$ = Amount of methane in the LFG which is sent to the natural gas distribution network and/or dedicated pipeline and/or to the trucks in year y (t CH₄/yr)

The working hours of the power plant(s), boiler(s), air heater(s) and kiln(s) should be monitored, and no emission reduction should be claimed for methane destruction during non- working hours.

The project utilizes the LFG only for power generation. Therefore:

$$F_{CH_4, PJ, y} = F_{CH_4, EL, y} \quad \text{Equation (5)}$$

$F_{CH_4, EL, y}$ is determined using the “Tool to determine the mass flow of a greenhouse gas in a gaseous stream”. The following requirements apply:

- (a) As per the gaseous stream tool, if the LFG is used for multiple purposes (e.g. flaring or energy generation), and all methane destruction devices are verified to be operational (e.g. by means of flame detectors records, energy generated), a single flow meter may be used to record the flow into multiple destruction devices. The destruction efficiency of the least efficient among the destruction devices shall be used as the destruction efficiency for all destruction devices monitored by this flow meter. If there are any periods for which one or more destruction devices are not operational, paragraph 5 (a) and (b) of the Appendix of the "Tool to determine the mass flow of a greenhouse gas in a gaseous stream" tool shall be followed;
- (b) CH₄ is the greenhouse gas for which the mass flow should be determined;
- (c) The simplification offered for calculating the molecular mass of the gaseous stream is valid (equations (3) or (17) in the tool);
- (d) The mass flow should be calculated on an hourly basis for each hour h in year y;
- (e) The mass flow calculated for hour h is 0 if the equipment is not working in hour h ($O_{pj, h} = \text{not working}$), the hourly values are then summed to a yearly unit basis.

Amount of the methane used for power generation ($F_{CH_4, EL, y}$)

The “Tool to determine the mass of a greenhouse gas in a gaseous stream” provides following 6 options for measuring mass flow of a greenhouse gas i in a gaseous stream.

Table 4.1 Measurement options

| Option | Flow of gaseous stream | Volumetric Fraction |
|--------|------------------------|---------------------|
| | | |

| | | |
|---|-----------------------|------------------|
| A | Volume flow-dry basis | Dry or wet basis |
| B | Volume flow-wet basis | Dry basis |
| C | Volume flow-wet basis | Wet basis |
| D | Mass flow- dry basis | Dry or wet basis |
| E | Mass flow-wet basis | Dry basis |
| F | Mass flow-wet basis | Wet basis |

In the gas stream, only CH₄ is the greenhouse gas. Therefore $F_{i,t} = F_{CH_4,EL,y}$.

The flow meter and gas analyzer are installed by the project participant to monitor the volumetric flow of the LFG and the volumetric fraction of CH₄ in the LFG, with both parameters monitored on a dry basis. Therefore, Option A of the “tool to determine the mass of a greenhouse gas in a gaseous stream” will be applied in the project. In addition, if in a particular interval it cannot be demonstrated that the gaseous stream is dry, then the flow measurement shall be assumed to be on a wet basis and the corresponding option from the table 2 showed in the “tool to determine the mass of a greenhouse gas in a gaseous stream” should be applied instead.

Option A

Option A is applicable where the volumetric flow of the LFG is measured on a dry basis. In order to demonstrate that the LFG gaseous stream is dry, the project participants shall:

- (a) Measure the moisture content of the gaseous stream ($C_{H_2O,t,db,n}$) and demonstrate that this is less or equal to 0.05 kg H₂O/m³ dry gas; or
- (b) Demonstrate that the temperature of the gaseous stream (T_t) is less than 60°C (331.15K) at the flow measurement point.

According to the daily records of the LFG treatment system, the temperature of the gaseous stream (T_t) is less than 60°C (331.15 K) at the flow measurement point, therefore method (b) is chosen.

The mass flow of CH₄ shall be determined as follows:

$$F_{i,t} = V_{t,db} \times v_{i,t,db} \times \rho_{i,t} \quad \text{Equation (6)}$$

$$\rho_{i,t} = \frac{P_t \times MM_i}{R_u \times T_t} \quad \text{Equation (7)}$$

Where:

- $F_{i,t}$ = Mass flow of greenhouse gas i in the gaseous stream in time interval t (kg gas/h)
- $V_{t,db}$ = Volumetric flow of the gaseous stream in time interval t on a dry basis (m³ dry gas/h)
- $v_{i,t,db}$ = Volumetric fraction of greenhouse gas i in the gaseous stream in a time interval t on a dry basis (m³ gas i/m³ dry gas)
- $\rho_{i,t}$ = Density of greenhouse gas i in the gaseous stream in time interval t (kg gas i/m³ dry gas)
- P_t = Absolute pressure of the gaseous stream in time interval t (101,325 Pa)
- MM_i = Molecular mass of greenhouse gas i (16.04 kg/kmol)
- R_u = Universal ideal gases constant (8,314 Pa.m³/kmol.k)
- T_t = Temperature of the gaseous stream in time interval t (273.15K)

All parameters about the LFG which is fed into the gas engines are converted automatically to normal conditions during the monitoring process. Therefore, P_t and T_t don't need to be monitored.

Step A.1.1: Ex ante estimation of $F_{CH_4,PJ,y}$

An ex ante estimate of $F_{CH_4,PJ,y}$ is required to estimate baseline emission of methane from the SWDS (according to equation (3)) in order to estimate the emission reductions of the project activity in the project description. It is determined as follows:

$$F_{CH_4,PJ,y} = \eta_{PJ} \times BE_{CH_4,SWDS,y} / GWP_{CH_4} \quad \text{Equation (8)}$$

Where:

- $F_{CH_4,PJ,y}$ = Amount of methane in the LFG which is flared and/or used in the project activity in year y (t CH₄/yr)

$BE_{CH_4, SWDS, y}$ = Amount of methane in the LFG that is generated from the SWDS in the baseline scenario in year y (t CO₂e/yr)

η_{PJ} = Efficiency of the LFG capture system that will be installed in the project activity

GWP_{CH_4} = Global warming potential of CH₄ (t CO₂e/t CH₄)

$BE_{CH_4, SWDS, y}$ is determined using the methodological tool “Emissions from solid waste disposal sites”. The following guidance should be taken into account when applying the tool:

f_y in the tool shall be assigned a value of 0 because the amount of LFG that would have been captured and destroyed is already accounted for in equation 2 of this methodology;

In the tool, x begins with the year that the SWDS started receiving wastes (e.g. the first year of SWDS operation); and sampling to determine the fractions of different waste types is not necessary because the waste composition can be obtained from previous studies.

$BE_{CH_4, SWDS, y}$ is determined using the methodological tool “Emissions from solid waste disposal sites”. For the project, the amount of methane generated from disposal of waste at the SWDS for year y ($BE_{CH_4, SWDS, y}$) is calculated using first order decay (FOD) model as follows:

$$BE_{CH_4, SWDS, y} = \varphi_y \times (1 - f_y) \times GWP_{CH_4} \times (1 - OX) \times \frac{16}{12} \times F \times DOC_{f, y} \times MCF_y \times \sum_{x=1}^y \sum_j (W_{j, x} \times DOC_j \times e^{-kj \times (y-x)} \times (1 - e^{kj}))$$

Equation(9)

$BE_{CH_4, SWDS, y}$ = Baseline methane emissions occurring in the year y

φ_y = Model correction factor to account for model uncertainties for year y

f_y = Fraction of methane captured at the SWDS and flared, combusted or used in another manner that prevents the emission of methane to the atmosphere in year y

GWP_{CH_4} = Global Warming Potential of methane

OX = Oxidation factor (reflecting the amount of methane from SWDS that is oxidized in the soil or other material covering the waste)

F = Fraction of methane in the SWDS gas (volume fraction)

| | | |
|-------------|--|------|
| $DOC_{t,y}$ | = Fraction of degradable organic carbon (DOC) that decomposes under the specific conditions occurring in the SWDS in year y (weight fraction) | |
| MCF_y | = Methane correction factor for year y | |
| $W_{j,x}$ | = Amount of solid waste type j disposed or prevented from disposal in the SWDS in the year x | t |
| DOC_j | = Fraction of degradable organic carbon in the waste type j (weight fraction) | |
| k_j | = Decay rate for waste type j | 1/yr |
| j | = Type of residual waste or types of waste in the MSW | |
| x | = As per ACM0001 version 19.0, x begins with the year that the SWDS started receiving wastes (e.g. the first year of SWDS operation). x runs from the first year of landfill operation ($x=1$) to the year for which emission are calculated ($x=y$) | |
| y | = Year of the crediting period for which methane emissions are calculated (y is a consecutive period of 12 months) | |

Step A.2: Determination of $F_{CH_4,BL,y}$

This section provides a procedure to determine the amount of methane that would have been captured and destroyed (by flaring) in the baseline due to regulatory or contractual requirements, to address safety and odour concerns, or for other reasons (collectively referred to as requirement in this section). The four cases in Table 4.2 are distinguished. The appropriate case should be identified, and the corresponding instructions followed.

Table 4.2 Cases for determining methane captured and destroyed in the baseline

| Situation at the start of the project activity | Requirement to destroy methane | Existing LFG capture and destruction system |
|--|--------------------------------|---|
| Case 1 | No | No |
| Case 2 | Yes | No |
| Case 3 | No | Yes |
| Case 4 | Yes | Yes |

There was no regulation or standard that enforces methane destruction in LFG when Huizhou landfill site began operating. Besides, Huizhou landfill site didn't collect and utilize the LFG prior to the implementation of the project activity, and no LFG capture and destruction system existing.

Therefore, the project is satisfied with the situation of Case 1: No requirement to destroy methane exists and no existing LFG capture system.

In this situation:

$$F_{CH_4, BL, y} = 0 \quad \text{Equation (10)}$$

Step: B Baseline emissions associated with electricity generation ($BE_{EC,y}$)

The baseline emissions associated with electricity generation in year y ($BE_{EC,y}$) shall be calculated using the "Methodological tool: Baseline, project and/or leakage emissions from electricity consumption and monitoring of electricity generation".

$$BE_{EC,y} = EC_{BL,k,y} \times EF_{EF,k,y} \times (1 + TDL_{k,y}) \quad \text{Equation (11)}$$

Where:

$BE_{EC,y}$ = Baseline emission from electricity consumption in year y (tCO₂/yr)

$EC_{BL,k,y}$ = Quantity of electricity that would be consumed by the baseline electricity consumer k in year y (MWh/yr)

$EF_{EF,k,y}$ = Emission factor for electricity generation for source k in year y (t CO₂/MWh)

$TDL_{k,y}$ = Average technical transmission and distribution losses for providing electricity to source k in year y

k = Sources of electricity consumption in the baseline

When applying the tool:

(a) The electricity sources k in the tool correspond to the sources of electricity generated identified in the selection of the most plausible baseline scenario; and

(b) $EC_{BL,k,y}$ in the tool is equivalent to the net amount of electricity generated using LFG in year y ($EG_{PJ,y}$).

According to the tool "Baseline, project and/or leakage emissions from electricity consumption and monitoring of electricity generation" (version 03.0), the project belongs to the case of Scenario A. A default value of $TDL_{k,y} = 3\%$ is used for baseline emission.

Determination of the emission factor for electricity generation ($EF_{EF,k,y}$)

Scenario A of the tool "Baseline, project and/or leakage emissions from electricity consumption and monitoring of electricity generation" is applicable for the project for the

electricity is purchased from the grid only, and no captive power plant is installed at the site of electricity consumption.

According to the tool “Baseline, project and/or leakage emissions from electricity consumption and monitoring of electricity generation”, $EF_{EF,k,y}$ is calculated using the “Tool to calculate the emission factor for an electricity system” ($EF_{EF,k,y} = EF_{grid,CM,y}$).

Details of the calculations and data follow the published data from the Chinese DNA², which uses official national statistics.

Project participants shall apply the following six steps:

- Step 1:** Identify the relevant electricity systems;
- Step 2:** Choose whether to include off-grid power plants in the project electricity system (optional)
- Step 3:** Select a method to determine the operating margin (OM);
- Step 4:** Calculate the operating margin emission factor according to the selected method;
- Step 5:** Calculate the build margin (BM) emission factor;
- Step 6:** Calculate the combined margin (CM) emission factor.

Step 1: Identify the relevant electricity systems

Ministry of Ecology and Environment of the People’s Republic of China has published a delineation of the project electricity system and connected electricity systems, so the project adopt the delineation of project electricity system and connected electricity system published by Ministry of Ecology and Environment of the People’s Republic of China. The power generated by the project displaces the equivalent electricity generated by the China Southern Power Grid.

In addition, there is net imported power to China Southern Power Grid from the East China Power Grid. According to the “Tool to calculate the emission factor for an electricity system”, use one of the following options to determine the CO₂ emission factor for net electricity imports from a connected electricity system:

² <http://www.mee.gov.cn/ywgz/ydqhbh/wsqtzkz/202012/W020201229610353340851.pdf>

- (a) 0 tCO₂/MWh; or
- (b) The simple operating margin emission rate of the exporting grid, determined as described in Step 4 section 6.4.1, if the conditions for this method, as described in Step 3 below, apply to the exporting grid; or
- (c) The simple adjusted operating margin emission rate of the exporting grid, determined as described in Step 4 section 6.4.2 below; or
- (d) The weighted average operating margin (OM) emission rate of the exporting grid, determined as described in Step 4 section 6.4.4 below.

The PD will choose option (b) to calculate the CO₂ emission factor for net electricity imports for the China Southern Power Grid.

According to the available data of 2015-2017, the corresponding marginal emission factors of electricity are calculated, and weighted average is carried out to obtain the marginal emission factors of electricity.

Step 2. Choose whether to include off-grid power plants in the project electricity system (optional).

Option I: Only grid power plants are included in the calculation.

Option II: Both grid power plants and off-grid power plants are included in the calculation.

Following the calculation of the Ministry of Ecology and Environment of the People's Republic of China, and statistical data is available, Option I is chosen.

Step 3. Select a method to determine the operating margin (OM)

“Tool to calculate the emission factor for an electricity system (Version 7.0)” offers four methods for the calculation of the operating margin emission factor(s) ($EF_{grid,OM,y}$):

- (a) Simple OM; or
- (b) Simple adjusted OM; or
- (c) Dispatch data analysis OM; or
- (d) Average OM.

Method (a) Simple OM is chosen for calculation and low-cost/must-run resources constitute less than 50% of the total grid generation in average of the five most recent years³.

For simple OM, the emission factor can be calculated using either of the two following data vintages:

³ China Electric Power Yearbook 2014-2018, the average of the five most recent years from year 2013 to 2017 is 46.91%.

(a) Ex ante option: If the ex ante option is chosen, the emission factor is determined once at the validation stage, thus no monitoring and recalculation of the mission factor during the crediting period is required. For grid power plants, use a 3-year generation-weighted average, based on the most recent data available at the time of submission of the CDM-PDD to the DOE for validation. For off-grid power plants, use a single calendar year within the 5 most recent calendar years prior to the time of submission of the CDM-PDD for validation;

(b) Ex post option: If the ex post option is chosen, the emission factor is determined for the year in which the project activity displaces grid electricity, requiring the emissions factor to be updated annually during monitoring. If the data required to calculate the emission factor for year y is usually only available later than six months after the end of year y , alternatively the emission factor of the previous year $y-1$ may be used. If the data is usually only available 18 months after the end of year y , the emission factor of the year proceeding the previous year $y-2$ may be used. The same data vintage (y , $y-1$ or $y-2$) should be used throughout all crediting periods

Project participant employs ex ante option for its operation margin calculation.

Step 4. Calculate the operating margin emission factor according to the selected method

The simple OM emission factor is calculated as the generation-weighted average CO₂ emissions per unit net electricity generation (tCO₂/MWh) of all generating power plants serving the system, not including low-cost / must-run power plants / units.

The simple OM may be calculated by one of the following two options:

- (a) Option A: Based on the net electricity generation and a CO₂ emission factor of each power unit; or
- (b) Option B: Based on the total net electricity generation of all power plants serving the system and the fuel types and total fuel consumption of the project electricity system. Option B can only be used if:
 - (i) The necessary data for Option A is not available: and
 - (ii) Only nuclear and renewable power generation are considered as low-cost/must-run power sources and the quantity of electricity supplied to the grid by these sources is known; and
 - (iii) Off-grid power plants are not included in the calculation (i.e., if Option I has been chosen in Step 2).

Since the data of each power plant/unit is unavailable, Option A is not applicable to the project. The project adopts Option B to calculate the operating margin emission factor ($EF_{grid,OM,y}$) of CSPG as follows:

$$EF_{grid,OM,y} = \frac{\sum_i (FC_{i,y} \cdot NCV_{i,y} \cdot EF_{CO_2,i,y})}{EG_y} \quad \text{Equation (12)}$$

- $EF_{grid,OM,y}$ = Simple operating margin CO₂ emission factor in year y (t CO₂/MWh) in the relevant electricity systems
- $FC_{i,y}$ = Amount of fuel type i consumed in the project electricity system in year y (mass or volume unit)
- $NCV_{i,y}$ = Net calorific value (energy content) of fuel type i in year y (GJ/mass or volume unit)
- $EF_{CO_2,i,y}$ = CO₂ emission factor of fuel type i in year y (tCO₂/GJ)
- EG_y = Net electricity generated and delivered to the grid by all power sources serving the system, not including low-cost/must-run power plants/units, in year y (MWh)
- i = All fuel types combusted in power sources in the project electricity system in year y
- y = The relevant year as per the data vintage chosen in Step 3.

Based on the data available, the three-year average operating margin emission factor is calculated as a full-generation-weighted average of the emission factors. Details of the calculations and data follow the published data from the Chinese DNA, which uses official national statistics. According to the latest data from the Ministry of Ecology and Environment of China, the operating margin emission factor for 2015, 2016 and 2017 are calculated based on the data above. The three-year average is calculated as a weighted average of the emission factors. The Operational Margin Emission Factor is 0.8042 tCO₂/MWh for CSCG⁴.

Step 5. Calculate the build margin emission factor

In terms of vintage of data, project participants can choose between one of the following two options:

⁴ <http://www.mee.gov.cn/ywgz/ydqhbh/wsqtz/202012/W020201229610353816665.pdf>

Option 1: For the first crediting period, calculate the build margin emission factor ex ante based on the most recent information available on units already built for sample group m at the time of CDM PDD submission to the DOE for validation. For the second crediting period, the build margin emission factor should be updated based on the most recent information available on units already built at the time of submission of the request for renewal of the crediting period to the DOE. For the third crediting period, the build margin emission factor calculated for the second crediting period should be used. This option does not require monitoring the emission factor during the crediting period.

Option 2: For the first crediting period, the build margin emission factor shall be updated annually, ex-post, including those units built up to the year of registration of the project activity or, if information up to the year of registration is not yet available, including those units built up to the latest year for which information is available. For the second crediting period, the build margin emissions factor shall be calculated ex ante, as described in Option 1 above. For the third crediting period, the build margin emission factor calculated for the second crediting period should be used.

The project applies option 1 to calculate the build margin emission factor ex-ante.

According to the “Tool to calculate the emission factor for an electricity system”, the sample group of power units m used to calculate the build margin should be determined as per the following procedure, consistent with the data vintage selected above:

(a) Identify the set of five power units, excluding power units registered as CDM project activities, that started to supply electricity to the grid most recently ($SET_{5\text{-units}}$) and determine their annual electricity generation ($AEG_{SET_{5\text{-units}}}$, in MWh);

(b) Determine the annual electricity generation of the project electricity system, excluding power units registered as CDM project activities (AEG_{total} , in MWh). Identify the set of power units, excluding power units registered as CDM project activities, that started to supply electricity to the grid most recently and that comprise 20% of AEG_{total} (if 20% falls on part of the generation of a unit, the generation of that unit is fully included in the calculation) ($SET_{\geq 20\%}$) and determine their annual electricity generation ($AEG_{SET_{\geq 20\%}}$, in MWh);

(c) From $SET_{5\text{-units}}$ and $SET_{\geq 20\%}$ select the set of power units that comprises the larger annual electricity generation (SET_{sample});

Identify the date when the power units in SET_{sample} started to supply electricity to the grid. If none of the power units in SET_{sample} started to supply electricity to the grid more than 10 years ago, then use SET_{sample} to calculate the build margin. In this case, ignore steps (d), (e) and (f).

Otherwise:

(d) Exclude from SET_{sample} the power units which started to supply electricity to the grid more than 10 years ago. Include in that set the power units registered as CDM project activity, starting with power units that started to supply electricity to the grid most recently, until the electricity generation of the new set comprises 20% of the annual electricity generation of the project electricity system (if 20% falls on part of the generation of a unit, the generation of that unit is fully included in the calculation) to the extent is possible. Determine for the resulting set ($SET_{sample-CDM}$) the annual electricity generation ($AEG_{SET-sample-CDM}$, in MWh);

If the annual electricity generation of that set comprises at least 20% of the annual electricity generation of the project electricity system (i.e. $AEG_{SET-sample-CDM} \geq 0.2 \times AEG_{total}$), then use the sample group $SET_{sample-CDM}$ to calculate the build margin. Ignore steps (e) and (f).

Otherwise:

- (e) Include in the sample group $SET_{sample-CDM}$ the power units that started to supply electricity to the grid more than 10 years ago until the electricity generation of the new set comprises 20% of the annual electricity generation of the project electricity system (if 20% falls on part of the generation of a unit, the generation of that unit is fully included in the calculation);
- (f) The sample group of power units m used to calculate the build margin is the resulting set ($SET_{sample-CDM > 10yrs}$).

The build margin emissions factor is the generation-weighted average emission factor (tCO_2/MWh) of all power units m during the most recent year y for which power generation data is available, calculated as follows:

$$EF_{grid, BM, y} = \frac{\sum_m (EG_{m, y} \times EF_{EL, m, y})}{\sum_m EG_{m, y}} \quad \text{Equation (13)}$$

Where:

- $EF_{grid, BM, y}$ = Build margin CO_2 emission factor in year y (tCO_2/MWh).
- $EG_{m, y}$ = Net quantity of electricity generated and delivered to the grid by power unit m in year y (MWh).
- $EF_{EL, m, y}$ = CO_2 emission factor of power unit m in year y (tCO_2/MWh).
- m = Power units included in the build margin.
- y = Most recent historical year for which power generation data is available.

Following all the steps above, the build margin emission factor, $EF_{grid,BM,y}$ of the CSPG is calculated to be 0.2135 tCO₂/MWh from the data of the Ministry of Ecology and Environment of China⁵.

Step 6. Calculate the combined margin emission factor

Combined Margin emission factor ($EF_{grid,CM,y}$) is calculated as the weighted average of the operating margin emission factor ($EF_{grid,OM,y}$) and the build margin emission factor ($EF_{grid,BM,y}$), where the weights ω_{OM} and ω_{BM} , by default, are 0.5 and 0.5 in the first crediting period, and $EF_{grid,OM,y}$ and $EF_{grid,BM,y}$ are calculated as described above and are expressed in tCO₂/MWh.

$$EF_{grid,CM,y} = \omega_{OM} \times EF_{grid,OM,y} + \omega_{BM} \times EF_{grid,BM,y} \quad \text{Equation (14)}$$

Where,

| | |
|------------------|---|
| $EF_{grid,BM,y}$ | = Build margin CO ₂ emission factor in year y (tCO ₂ /MWh) |
| $EF_{grid,OM,y}$ | = Operating margin CO ₂ emission factor in year y (tCO ₂ /MWh) |
| ω_{OM} | = Weighting of operating margin emissions factor (%) |
| ω_{BM} | = Weighting of build margin emissions factor (%) |

$$EF_{grid,CM,y} = 0.5 \times 0.8042 + 0.5 \times 0.2135 = 0.50885 \text{ (tCO}_2\text{/MWh)}$$

The $EF_{OM,y}$, $EF_{BM,y}$ and $EF_{grid,CM,y}$ are ex-ante calculation and are fixed during the credit period.

4.2 Project Emissions

Considering when electricity generators will be under regular maintenance and sometimes shut down, the electricity will be purchased from the CSPG during this period of time. Therefore, there will be project emissions, which is calculated following the latest version of “Tool to calculate baseline, project and/or leakage emissions from electricity consumption”.

Project emissions are calculated as follows:

$$PE_y = PE_{EC,y} + PE_{FC,y} + PE_{DT,y} + PE_{SP,y} \quad \text{Equation (15)}$$

Where:

⁵<http://www.mee.gov.cn/ywgz/ycqhbh/wsqtzkz/202012/W020201229610353340851.pdf>

- PE_y = Project emissions in year y (t CO₂/yr)
- $PE_{EC,y}$ = Emissions from consumption of electricity due to the project activity in year y (t CO₂/yr)
- $PE_{FC,y}$ = Emissions from consumption of fossil fuels due to the project activity, for purpose other than electricity generation, in year y (t CO₂/yr)
- $PE_{DT,y}$ = Emissions from the distribution of compressed/liquefied LFG using trucks, in year y (t CO₂/yr)
- $PE_{SP,y}$ = Emissions from the supply of LFG to consumers through a dedicated pipeline, in year y (t CO₂/yr)

The project does not include any activities consuming fossil fuels except electricity generation, so $PE_{FC,y}$ will be 0. The project does not involve the distribution of compressed/liquefied LFG using trucks and supply of LFG to consumers through a dedicated pipeline, Therefore, $PE_{FC,y}$, $PE_{DT,y}$, $PE_{SP,y}$ will be 0. Hence, PE_y is the same with $PE_{EC,y}$.

$PE_{EC,y}$ is determined by “Tool to calculate baseline, project and/or leakage emissions from electricity consumption” as follow:

$$PE_{EC,y} = \sum_j EC_{PJ,j,y} * EF_{EL,j,y} * (1 + TDL_{j,y}) \quad \text{Equation (16)}$$

Where:

$PE_{EC,y}$ = Project emissions from electricity consumption in year y (tCO₂/yr)

$EC_{PJ,j,y}$ = Quantity of electricity consumed by the project electricity consumption source j in year y(MWh/yr)

$EF_{EL,j,y}$ = Emission factor for electricity generation for source j in year y(tCO₂/MWh)

$TDL_{j,y}$ = Average technical transmission and distribution losses for providing electricity to source j in year y

The “Tool to calculate baseline, project and/or leakage emissions from electricity consumption” provides 3 scenarios for different sources of electricity consumption. Since the electricity generated through the project is consumed solely from grid (CSPG), scenario A is applicable. In the case of applying scenario A, two options are available for determining emission factor. For this project, Option A1 ($EF_{EL,j,y} = EF_{grid,CM,y}$) is chosen. A default values of $TDL_{j,y} = 20\%$ is used for project emission.

For simplification, $PE_{EC,y}$ will be 0 in the ex-ante calculation and will be monitored ex post in the verification period.

4.3 Leakage

No leakage effects are accounted for under this methodology.

4.4 Net GHG Emission Reductions and Removals

Emission reductions are calculated as follows:

$$ER_y = BE_y - PE_y \quad \text{Equation (17)}$$

Where,

ER_y = Emission reductions in year y (t CO₂e/yr)

BE_y = Baseline emissions in year y (t CO₂e/yr)

PE_y = Project emissions in year y (t CO₂e/yr)

| Year | Estimated baseline emissions or removals (tCO ₂ e) | Estimated project emissions or removals (tCO ₂ e) | Estimated leakage emissions (tCO ₂ e) | Estimated net GHG emission reductions or removals (tCO ₂ e) |
|-------------------------|---|--|--|--|
| 14/12/2020 - 31/12/2020 | 15,434 | 0 | 0 | 15,434 |
| 2021 | 333,083 | 0 | 0 | 333,083 |
| 2022 | 344,002 | 0 | 0 | 344,002 |
| 2023 | 349,151 | 0 | 0 | 349,151 |
| 2024 | 350,284 | 0 | 0 | 350,284 |
| 2025 | 272,324 | 0 | 0 | 272,324 |
| 2026 | 217,522 | 0 | 0 | 217,522 |
| 01/01/2027 - 13/12/2027 | 169,656 | 0 | 0 | 169,656 |

| | | | | |
|---------------------|-----------|---|---|-----------|
| Total estimated ERs | 2,051,457 | 0 | 0 | 2,051,457 |
|---------------------|-----------|---|---|-----------|

5 MONITORING

5.1 Data and Parameters Available at Validation

| | |
|---|---|
| Data / Parameter | OX_{top_layer} |
| Data unit | - |
| Description | Fraction of methane that would be oxidized in the top layer of the SWDS in the baseline |
| Source of data | “Emission from the solid waste disposal sites” (version 8.0) |
| Value applied | 0.1 |
| Justification of choice of data or description of measurement methods and procedures applied | - |
| Purpose of Data | Calculation of baseline emissions |
| Comments | - |

| | |
|--|---|
| Data / Parameter | GWP_{CH_4} |
| Data unit | tCO ₂ e/t CH ₄ |
| Description | Global warming potential of CH ₄ |
| Source of data | IPCC |
| Value applied | Default value of 28. Shall be updated according to any future COP/CMP decisions |
| Justification of choice of data or description of measurement methods | - |

| | |
|------------------------|-----------------------------------|
| and procedures applied | |
| Purpose of Data | Calculation of baseline emissions |
| Comments | - |

| | |
|--|---|
| Data / Parameter | ρ_{CH_4} |
| Data unit | t/m ³ |
| Description | Density of methane gas at Normal Conditions |
| Source of data | - |
| Value applied | 0.0007168 (Normal Conditions: 0°C and 101.325kPa) |
| Justification of choice of data or description of measurement methods and procedures applied | - |
| Purpose of Data | Calculation of baseline emissions |
| Comments | - |

| | |
|--|---|
| Data / Parameter | η_{PJ} |
| Data unit | - |
| Description | Efficiency of the LFG capture system that was installed in the project activity |
| Source of data | FSR of the project |
| Value applied | 60% |
| Justification of choice of data or description of measurement methods and procedures applied | - |
| Purpose of Data | Calculation of baseline emissions |

| | |
|----------|---|
| Comments | - |
|----------|---|

| | |
|--|--|
| Data / Parameter | Φ_x |
| Data unit | - |
| Description | The model correction factor to account for model uncertainties |
| Source of data | Default value of the tool “Emissions from solid waste disposal sites” (version 08.0) |
| Value applied | 0.75 |
| Justification of choice of data or description of measurement methods and procedures applied | Application A is used to decide the value, and the value of wet condition used for the project since the MAP/PET >1. |
| Purpose of Data | - |
| Comments | - |

| | |
|--|---|
| Data / Parameter | f_y |
| Data unit | - |
| Description | Fraction of methane captured at the SWDS and flared, combusted or used in another manner that prevents the emissions of methane to the atmosphere in year y |
| Source of data | The tool “Emissions from solid waste disposal sites” (version 08.0) |
| Value applied | 0 |
| Justification of choice of data or description of measurement methods and procedures applied | It has been considered in the section 4.1, equation (9). Therefore, $f_y=0$ |
| Purpose of Data | |

| | |
|-----------------|---|
| Comments | - |
|-----------------|---|

| | |
|---|--|
| Data / Parameter | OX |
| Data unit | - |
| Description | Oxidation factor |
| Source of data | Based on an extensive review of published literature on this subject, including the IPCC2006 Guidelines for National Greenhouse Gas Inventories. |
| Value applied | 0.1 |
| Justification of choice of data or description of measurement methods and procedures applied | - |
| Purpose of Data | Calculation of baseline emissions |
| Comments | - |

| | |
|---|--|
| Data / Parameter | F |
| Data unit | - |
| Description | Fraction of methane in the SWDS gas (volume fraction) |
| Source of data | IPCC 2006 Guidelines for National Greenhouse Gas Inventories |
| Value applied | 0.5 |
| Justification of choice of data or description of measurement methods and procedures applied | - |
| Purpose of Data | Calculation of baseline emissions |
| Comments | - |

| | |
|---|--|
| Data / Parameter | DOC _{t,y} |
| Data unit | Weight fraction |
| Description | Default value for the fraction of degradable organic carbon (DOC) in MSW that decomposed in the SWDS |
| Source of data | IPCC 2006 Guidelines for National Greenhouse Gas Inventories |
| Value applied | 0.5 |
| Justification of choice of data or description of measurement methods and procedures applied | - |
| Purpose of Data | Calculation of baseline emissions |
| Comments | - |

| | |
|---|---|
| Data / Parameter | MCF _y |
| Data unit | - |
| Description | Methane correction factor |
| Source of data | IPCC 2006 Guidelines for National Greenhouse Gas Inventories |
| Value applied | 1.0 |
| Justification of choice of data or description of measurement methods and procedures applied | The project using application A to decide the value of MCF _y . The Huizhou landfill site has controlled placement of waste, mechanical compacting and levelling of the waste, So MCF _y value of 1.0 for anaerobic managed solid waste disposal sites should be applied in line with "Emissions from solid waste disposal sites" (version 8.0) |
| Purpose of Data | Calculation of baseline emissions |

| Comments | - | | | | | | | | | | | | | | | | | | | | | | | | | | | | | | | | | | | | | | | | | | | | | | | | | | | | | |
|-------------------------|---|-------------------------------|------|------------------------------|------|---------|------|---------|------|---------|------|---------|------|---------|------|---------|------|---------|------|---------|------|---------|------|---------|------|---------|------|---------|------|---------|------|---------|------|---------|------|---------|------|---------|------|---------|------|---------|------|---------|------|---------|------|---------|------|---------|------|---------|------|---------|
| Data / Parameter | W_x | | | | | | | | | | | | | | | | | | | | | | | | | | | | | | | | | | | | | | | | | | | | | | | | | | | | | |
| Data unit | t | | | | | | | | | | | | | | | | | | | | | | | | | | | | | | | | | | | | | | | | | | | | | | | | | | | | | |
| Description | Quantity of MSW land filled during 2000-2024 | | | | | | | | | | | | | | | | | | | | | | | | | | | | | | | | | | | | | | | | | | | | | | | | | | | | | |
| Source of data | Records from landfill operator and calculated ex ante | | | | | | | | | | | | | | | | | | | | | | | | | | | | | | | | | | | | | | | | | | | | | | | | | | | | | |
| Value applied | <table border="1"> <thead> <tr> <th>Year</th> <th>Annual landfilled MSW (tons)</th> </tr> </thead> <tbody> <tr><td>2000</td><td>205,000</td></tr> <tr><td>2001</td><td>208,000</td></tr> <tr><td>2002</td><td>212,000</td></tr> <tr><td>2003</td><td>216,000</td></tr> <tr><td>2004</td><td>220,000</td></tr> <tr><td>2005</td><td>226,000</td></tr> <tr><td>2006</td><td>232,000</td></tr> <tr><td>2007</td><td>235,000</td></tr> <tr><td>2008</td><td>240,000</td></tr> <tr><td>2009</td><td>190,000</td></tr> <tr><td>2010</td><td>190,000</td></tr> <tr><td>2011</td><td>193,000</td></tr> <tr><td>2012</td><td>195,000</td></tr> <tr><td>2013</td><td>200,000</td></tr> <tr><td>2014</td><td>292,000</td></tr> <tr><td>2015</td><td>419,750</td></tr> <tr><td>2016</td><td>576,700</td></tr> <tr><td>2017</td><td>627,800</td></tr> <tr><td>2018</td><td>669,775</td></tr> <tr><td>2019</td><td>729,270</td></tr> <tr><td>2020</td><td>788,400</td></tr> <tr><td>2021</td><td>748,980</td></tr> <tr><td>2022</td><td>711,531</td></tr> <tr><td>2023</td><td>675,954</td></tr> <tr><td>2024</td><td>642,157</td></tr> </tbody> </table> | | Year | Annual landfilled MSW (tons) | 2000 | 205,000 | 2001 | 208,000 | 2002 | 212,000 | 2003 | 216,000 | 2004 | 220,000 | 2005 | 226,000 | 2006 | 232,000 | 2007 | 235,000 | 2008 | 240,000 | 2009 | 190,000 | 2010 | 190,000 | 2011 | 193,000 | 2012 | 195,000 | 2013 | 200,000 | 2014 | 292,000 | 2015 | 419,750 | 2016 | 576,700 | 2017 | 627,800 | 2018 | 669,775 | 2019 | 729,270 | 2020 | 788,400 | 2021 | 748,980 | 2022 | 711,531 | 2023 | 675,954 | 2024 | 642,157 |
| Year | Annual landfilled MSW (tons) | | | | | | | | | | | | | | | | | | | | | | | | | | | | | | | | | | | | | | | | | | | | | | | | | | | | | |
| 2000 | 205,000 | | | | | | | | | | | | | | | | | | | | | | | | | | | | | | | | | | | | | | | | | | | | | | | | | | | | | |
| 2001 | 208,000 | | | | | | | | | | | | | | | | | | | | | | | | | | | | | | | | | | | | | | | | | | | | | | | | | | | | | |
| 2002 | 212,000 | | | | | | | | | | | | | | | | | | | | | | | | | | | | | | | | | | | | | | | | | | | | | | | | | | | | | |
| 2003 | 216,000 | | | | | | | | | | | | | | | | | | | | | | | | | | | | | | | | | | | | | | | | | | | | | | | | | | | | | |
| 2004 | 220,000 | | | | | | | | | | | | | | | | | | | | | | | | | | | | | | | | | | | | | | | | | | | | | | | | | | | | | |
| 2005 | 226,000 | | | | | | | | | | | | | | | | | | | | | | | | | | | | | | | | | | | | | | | | | | | | | | | | | | | | | |
| 2006 | 232,000 | | | | | | | | | | | | | | | | | | | | | | | | | | | | | | | | | | | | | | | | | | | | | | | | | | | | | |
| 2007 | 235,000 | | | | | | | | | | | | | | | | | | | | | | | | | | | | | | | | | | | | | | | | | | | | | | | | | | | | | |
| 2008 | 240,000 | | | | | | | | | | | | | | | | | | | | | | | | | | | | | | | | | | | | | | | | | | | | | | | | | | | | | |
| 2009 | 190,000 | | | | | | | | | | | | | | | | | | | | | | | | | | | | | | | | | | | | | | | | | | | | | | | | | | | | | |
| 2010 | 190,000 | | | | | | | | | | | | | | | | | | | | | | | | | | | | | | | | | | | | | | | | | | | | | | | | | | | | | |
| 2011 | 193,000 | | | | | | | | | | | | | | | | | | | | | | | | | | | | | | | | | | | | | | | | | | | | | | | | | | | | | |
| 2012 | 195,000 | | | | | | | | | | | | | | | | | | | | | | | | | | | | | | | | | | | | | | | | | | | | | | | | | | | | | |
| 2013 | 200,000 | | | | | | | | | | | | | | | | | | | | | | | | | | | | | | | | | | | | | | | | | | | | | | | | | | | | | |
| 2014 | 292,000 | | | | | | | | | | | | | | | | | | | | | | | | | | | | | | | | | | | | | | | | | | | | | | | | | | | | | |
| 2015 | 419,750 | | | | | | | | | | | | | | | | | | | | | | | | | | | | | | | | | | | | | | | | | | | | | | | | | | | | | |
| 2016 | 576,700 | | | | | | | | | | | | | | | | | | | | | | | | | | | | | | | | | | | | | | | | | | | | | | | | | | | | | |
| 2017 | 627,800 | | | | | | | | | | | | | | | | | | | | | | | | | | | | | | | | | | | | | | | | | | | | | | | | | | | | | |
| 2018 | 669,775 | | | | | | | | | | | | | | | | | | | | | | | | | | | | | | | | | | | | | | | | | | | | | | | | | | | | | |
| 2019 | 729,270 | | | | | | | | | | | | | | | | | | | | | | | | | | | | | | | | | | | | | | | | | | | | | | | | | | | | | |
| 2020 | 788,400 | | | | | | | | | | | | | | | | | | | | | | | | | | | | | | | | | | | | | | | | | | | | | | | | | | | | | |
| 2021 | 748,980 | | | | | | | | | | | | | | | | | | | | | | | | | | | | | | | | | | | | | | | | | | | | | | | | | | | | | |
| 2022 | 711,531 | | | | | | | | | | | | | | | | | | | | | | | | | | | | | | | | | | | | | | | | | | | | | | | | | | | | | |
| 2023 | 675,954 | | | | | | | | | | | | | | | | | | | | | | | | | | | | | | | | | | | | | | | | | | | | | | | | | | | | | |
| 2024 | 642,157 | | | | | | | | | | | | | | | | | | | | | | | | | | | | | | | | | | | | | | | | | | | | | | | | | | | | | |
| | Waste type j | Weight Fraction (% wet waste) | | | | | | | | | | | | | | | | | | | | | | | | | | | | | | | | | | | | | | | | | | | | | | | | | | | | |
| | W1-Wood and wood products | 0.08 | | | | | | | | | | | | | | | | | | | | | | | | | | | | | | | | | | | | | | | | | | | | | | | | | | | | |

| | | |
|---|--|-------|
| | W2-Pulp, paper and cardboard | 0.076 |
| | W3-Food, food waste, beverages and tobacco | 0.545 |
| | W4-Textiles | 0.127 |
| | W5-Garden, yard and park waste | 0.049 |
| | W6-Glass, plastic, metal | 0.123 |
| Justification of choice of data or description of measurement methods and procedures applied | The data FSR of the project. | |
| Purpose of Data | Calculation of baseline emissions | |
| Comments | - | |

| | |
|-------------------------|--|
| Data / Parameter | DOC _j |
| Data unit | - |
| Description | Fraction of degradable organic carbon in the waste type j(weight fraction) |
| Source of data | “Emissions from solid waste disposal sites” (version 08.0) |

| | | |
|---|--|--|
| Value applied²⁴ | Waste type <i>j</i> | DOC _{<i>j</i>} (% wet waste) |
| | Wood and wood products | 43 |
| | pulp, paper and cardboard (other than sludge) | 40 |
| | Food and food waste | 15 |
| | Textile | 24 |
| | Garden, yard and park waste | 20 |
| | Glass, plastic, metal, other inert waste | 0 |
| Justification of choice of data or description of measurement methods and procedures applied | The climate condition of Huizhou landfill: Temperature: 22°C Mean annual precipitation: 1770 mm Potential evapotranspiration: 1719 mm | |
| Purpose of Data | Calculation of baseline emissions | |
| Comments | - | |

| | |
|-------------------------|--|
| Data / Parameter | k_j |
| Data unit | 1/yr |
| Description | Decay rate for the waste type <i>j</i> |
| Source of data | "Emissions from solid waste disposal sites" (version 08.0) |

| | | | |
|---|--|---|------------------------------------|
| Value applied | Waste type j | | k_j (MAT>20°C, MAP/PET> 1) |
| | Slowly degrading | Pulp, paper, cardboard (other than sludge), textile | 0.07 |
| | | Wood, wood products and straw | 0.035 |
| | Moderately degrading | Other (non- food) organic putrescible garden and park waste | 0.17 |
| | Rapidly degrading | Food, food waste, sewage sludge, beverages and tobacco | 0.40 |
| Justification of choice of data or description of measurement methods and procedures applied | The climate condition of Huizhou landfill: MAT (Mean annual Temperature): 22°C MAP (Mean annual precipitation): 1770 mm PET (Potential evapotranspiration): 1269 mm | | |
| Purpose of Data | Calculation of baseline emissions | | |
| Comments | | | |

| | |
|--|---|
| Data / Parameter | $EF_{grid,OM,y}$ |
| Data unit | tCO ₂ /MWh |
| Description | Operation margin emission factor of CSPG |
| Source of data | 2019 China baseline emission factor of regional power grid. |
| Value applied | 0.8042 |
| Justification of choice of data or description of | The value is published by Ministry of Ecology and |

| | |
|---|---|
| measurement methods and procedures applied | Environment of the People's Republic of China, based on China Electric Yearbook (2016-2018), Electricity Industry Statistics (2015- 2017), China Energy Statistic Yearbook (2016-2018) and IPCC data. |
| Purpose of Data | Calculation of baseline emissions |
| Comments | - |

| | |
|---|---|
| Data / Parameter | $EF_{grid, BM, y}$ |
| Data unit | tCO ₂ /MWh |
| Description | Build margin emission factor of CSPG |
| Source of data | 2019 China baseline emission factor of regional power grid. |
| Value applied | 0.2135 |
| Justification of choice of data or description of measurement methods and procedures applied | The value is published by Ministry of Ecology and Environment of the People's Republic of China, based on China Electric Yearbook (2014-2018), Electricity Industry Statistics (2015- 2017), China Energy Statistic Yearbook (2016-2018) and IPCC data. |
| Purpose of Data | Calculation of baseline emissions |
| Comments | - |

| | |
|-------------------------|--|
| Data / Parameter | $TDL_{j, y}$ and $TDL_{k, y}$ |
| Data unit | % |
| Description | Average technical transmission and distribution losses for providing electricity to source j,k in year y |
| Source of data | Baseline, project and/or leakage emissions from electricity consumption and monitoring of electricity generation (version 03.0). |
| Value applied | Use as default values of 20% for project consumption |

| | |
|--|---|
| | sources; Use as default values of 3% for baseline electricity consumption sources. i.e.: $TDL_{j,y} = 3\%$, $TDL_{k,y} = 20\%$ |
| Justification of choice of data or description of measurement methods and procedures applied | - |
| Purpose of Data | - |
| Comments | - |

5.2 Data and Parameters Monitored

| | |
|---|--|
| Data / Parameter | $F_{CH_4, BL, R, y}$ |
| Data unit | tCH ₄ /y |
| Description | Amount of methane in the LFG which is flared due to a requirement in year y |
| Source of data | Information of the host country's regulatory requirements relating to LFG, contractual requirements, or requirements to address safety and odour concerns. |
| Description of measurement methods and procedures to be applied | - |
| Frequency of monitoring/recording | Annually |
| Value applied | 0 |
| Monitoring equipment | - |
| QA/QC procedures to be applied | - |
| Purpose of data | Calculation of baseline emissions |

| | |
|---|--|
| Calculation method | - |
| Comments | Applicable to Case 1 of section 5.4.1.3 of ACM0001“Flaring or use of landfill gas” (version 19.0) |
| Data / Parameter | $P_{reg,y}$ |
| Data unit | Dimensionless |
| Description | Fraction of LFG that is required to be flared due to a requirement in year y |
| Source of data | Information of the host country’s regulatory requirements relating to LFG, contractual requirements, or requirements to address safety and odour concerns. |
| Description of measurement methods and procedures to be applied | - |
| Frequency of monitoring/recording | Annually |
| Value applied | 0 |
| Monitoring equipment | - |
| QA/QC procedures to be applied | - |
| Purpose of data | Calculation of baseline emissions |
| Calculation method | - |
| Comments | Applicable to Case 1 of section 5.4.1.3 of ACM0001“Flaring or use of landfill gas” (version 19.0) |

| | |
|--|---|
| Data / Parameter | $EG_{PJ,y}$ |
| Data unit | MWh |
| Description | Amount of electricity generated using LFG by the project activity in year y |
| Source of data | Project participant |
| Description of measurement methods and procedures to be applied | Measured continuously by electricity meter(bi-directional) installed at the project site. All data will be monitored and archived electronically. Double check by receipt of electricity sales. |
| Frequency of monitoring/recording | The recording frequency will be hourly measured and record, and monthly aggregated. |
| Value applied | |
| Monitoring equipment | Electricity meter E shown in the monitoring system as below. |
| QA/QC procedures to be applied | The calibration should be done once a year by a qualified third party. |
| Purpose of data | Calculation of baseline emissions |
| Calculation method | |
| Comments | |

| | |
|---|--|
| Data / Parameter | $EG_{EC,y}$ |
| Data unit | MWh |
| Description | Amount of electricity consumed by the project activity in year y |
| Source of data | Project participant |
| Description of measurement methods | Measured continuously by electricity meter(bi-directional) |

| | |
|-----------------------------------|--|
| and procedures to be applied | installed at the project site. All data will be monitored and archived electronically. Double check by receipt of electricity sales. |
| Frequency of monitoring/recording | The recording frequency will be hourly measured and record, and monthly aggregated. |
| Value applied | |
| Monitoring equipment | Electricity meter E shown in the monitoring system as below. |
| QA/QC procedures to be applied | The calibration should be done once a year by a qualified third party. |
| Purpose of data | Calculation of baseline emissions |
| Calculation method | |
| Comments | |

| | |
|---|---|
| Data / Parameter | $V_{t,db}$ |
| Data unit | m ³ dry gas/h |
| Description | Volumetric flow of the gaseous stream in time interval t on a dry basis |
| Source of data | Monitored by project participant |
| Description of measurement methods and procedures to be applied | Volume flow measurement always refer to the actual pressure and temperature. |
| Frequency of monitoring/recording | Measured continuously by a flow meter F (average hourly value should be used in the calculations of baseline emission reductions). Data to be aggregated monthly. |
| Value applied | |

| | |
|---------------------------------------|---|
| Monitoring equipment | Flow meter |
| QA/QC procedures to be applied | Flow meter should be subject to a regular maintenance and testing regime to ensure accuracy |
| Purpose of data | Calculation of project emissions |
| Calculation method | |
| Comments | |

| | |
|--|--|
| Data / Parameter | $V_{i,t,db}$ |
| Data unit | m ³ dry gas/h |
| Description | Volumetric fraction of greenhouse gas i in a time interval t on dry basis |
| Source of data | Monitored by project participant |
| Description of measurement methods and procedures to be applied | Continuous gas analyzer operating in operating in dry-basis. Volumetric flow measurement should always refer to the actual pressure and temperature. |
| Frequency of monitoring/recording | Continuous if not specified in the underlying methodology |
| Value applied | 50% (ex ante calculation) |
| Monitoring equipment | Gas analyzer |
| QA/QC procedures to be applied | Gas analyzer should be subject to a regular maintenance and testing regime to ensure accuracy |

| | |
|--------------------|-----------------------------------|
| Purpose of data | Calculation of baseline emissions |
| Calculation method | |
| Comments | |

| | |
|---|---|
| Data / Parameter | Management of SWDS |
| Data unit | - |
| Description | Management of SWDS |
| Source of data | Use different sources of data: (a) Original design of the landfill; (b) Technical specifications for the management of the SWDS; (c) Local or national regulations |
| Description of measurement methods and procedures to be applied | - |
| Frequency of monitoring/recording | Annually |
| Value applied | |
| Monitoring equipment | |
| QA/QC procedures to be applied | |
| Purpose of data | |
| Calculation method | |
| Comments | |

| | |
|--|---|
| Data / Parameter | Op _{j,h} |
| Data unit | - |
| Description | Operation of the equipment that consumes the LFG |
| Source of data | Project participant |
| Description of measurement methods and procedures to be applied | The captured LFG is consumed by gas generators. Operation of the gas generators is automatically monitored and recorded in the daily records. |
| Frequency of monitoring/recording | Hourly |
| Value applied | |
| Monitoring equipment | |
| QA/QC procedures to be applied | |
| Purpose of data | |
| Calculation method | |
| Comments | |

| | |
|--|---|
| Data / Parameter | CAPEX and OPEX |
| Data unit | CNY |
| Description | Total investment to implement the project and total cost to operate the project |
| Source of data | Engineering, procurement and construction contracts; and maintenance contracts |
| Description of measurement methods and procedures to be applied | - |

| | |
|--|--|
| applied | |
| Frequency of monitoring/recording | At the first issuance request after each phase of the project is fully implemented |
| Value applied | - |
| Monitoring equipment | - |
| QA/QC procedures to be applied | Audited by professional, independent financial auditors. The Designated Operational Entity (DOE) should only verify that the data provided corresponds to the data from independent financial auditors |
| Purpose of data | |
| Calculation method | |
| Comments | |

| | |
|--|---|
| Data / Parameter | Tariff of electricity exported |
| Data unit | CNY |
| Description | Tariff of the electricity exported |
| Source of data | Power purchase agreement |
| Description of measurement methods and procedures to be applied | - |
| Frequency of monitoring/recording | At the first issuance request after each phase of the project is fully implemented |
| Value applied | - |
| Monitoring equipment | - |
| QA/QC procedures to be applied | Audited by professional, independent financial auditors. The Designated Operational Entity (DOE) should only verify that the data provided corresponds to the data from |

| | |
|--------------------|---------------------------------|
| | independent financial auditors. |
| Purpose of data | |
| Calculation method | |
| Comments | |

5.3 Monitoring Plan

1. The requirement of monitoring plan

According to the “Monitoring Methodology ACM0001 (Version 19.0)”, the project participants will monitor the emission reductions (ERs) by methods, indicators, and frequency to ensure project ERs are measurable and real. The monitoring methodology is based on direct measurement of the amount of LFG captured and destroyed by the project and electricity generating units.

2. Responsibilities of operational and management structure

The project participant will implement this monitoring plan. The plan could be revised according to suggestions from Designated Operational Entity (DOE) and the practical circumstances, in order to keep it consistent, transparent and conservative during the monitoring process.

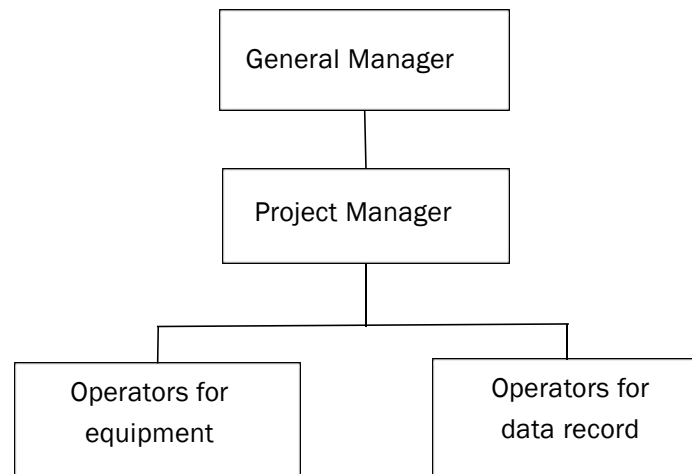

Figure 5.1 Operational and management structure

(1) Principal of the monitoring procedure

The general manager of the project is the leader of the monitoring tasks who sets out the responsibility of everyone in the monitoring system and establishes the related documents. The general manager ensures that staffs in the monitoring system has the ability to deal with the assigned tasks.

The Project manager will be responsible for aggregating the monitored data monthly and yearly, archiving and keeping data during the crediting period and two years after.

Operators will be in charge of data supervision, checking and inspecting the system. If necessary, they will have the responsibility for executing the emergency plan and drafting emergency situation reports.

(2) Executive person of the monitoring procedure

Project Manager: A Project Manager is appointed who is specifically responsible for training, checking the daily operation, reporting forms and archiving emergency situation reports. The Project Manager reports monthly to the General Manager (GM) about the project performance and monitored data. In the event that non-conformance in the performance to the mentioned procedures and/or functioning problems of the monitoring equipment are identified, the Project manager will inform the GM about the situation and work out relevant measures to be taken. The Project manager will also be responsible for aggregating the monitored data monthly and yearly, archiving and keeping data during the crediting period and two years after.

(3) Operators of the monitoring procedure

Operators will take turns to work in the control center 24 hours a day, 7 days a week. They will be in charge of data supervision, filling operation report forms and, checking and inspecting the system. If necessary, they will have the responsibility for executing the emergency plan and drafting emergency situation reports.

3. Monitoring system

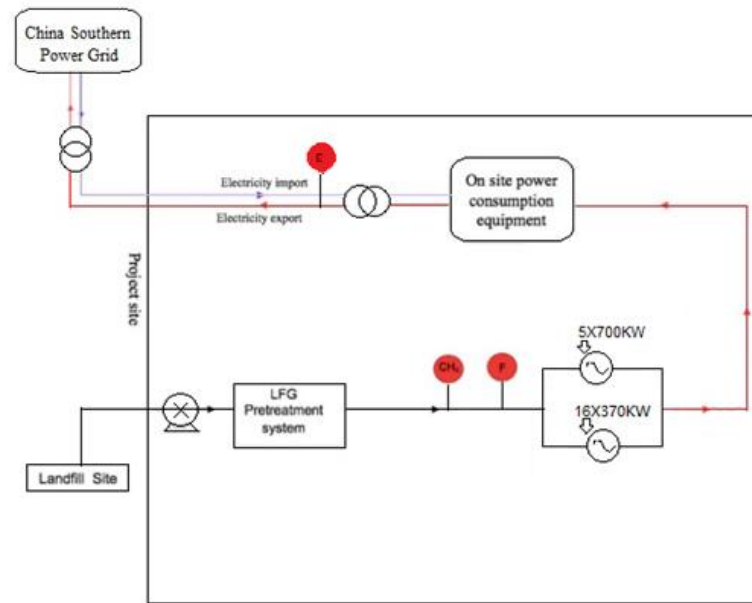

Figure 5.2 The monitoring flow chart

CH₄ - Gas analyzer to continuously measure methane fraction in LFG

F - Flow meter to continuously measure flow of LFG fed to the Power Plant

E - Bi-directional electricity meter to continuously measure the net electricity exported to CSPG and electricity imported from CSPG

QA/QC

All the monitoring devices listed above (flow meter, gas analyzer and electricity meter) will be chosen in accordance with VCS requirements and will be calibrated regularly for accuracy by qualified party according to the national regulations.

According to the Chinese national standard (Technical Management Code for Electricity Metering, DL/T448-2016), the electricity meter was properly configured and checked by both the project owner and the grid company before the project is in operation. The accuracy should not be less than 0.5S. The installation of flow meters and gas analyzers will fulfill the national standard (JJG1029-2007 and JJG693-2011).

To assist in future verifications, the calibration records, along with the data files of project monitoring will be kept in the archives by the project owner, and checked by Project Manager. When the data is not available from the main monitoring devices, the data measured by the back-up devices will be used.

Data Management

Specific staff will be appointed by the project owner to take the overall responsibility for monitoring GHG emission reductions and keeping all monitored data collected as part of monitoring archived electronically and be kept at least for 2 years after the end of the last crediting period.

Electronic data and documents will be regularly copied and archived via hard disk, and kept at least two years after the end of the last crediting period.

All written data and documents, including electricity receipts for cross-checking, will be copied and archived and kept at least two years after the end of the last crediting period.

Procedure in case of failure

In the case of a meter in fault, it shall be immediately repaired or replaced with another calibrated meter by a professional engineer, and the LFG or electricity generated during the period of erroneous measurement and replacement of the fault meter shall not be accounted for conservative consideration.