



Verified Carbon Standard

INNER MONGOLIA JINGNENG SAIHAN WIND FARM PHASE I PROJECT



Document Prepared by Climate Bridge (Shanghai) Ltd.

Project Title	Inner Mongolia Jingneng Saihan Wind Farm Phase I Project
Version	2.0
Report ID	NA
Date of Issue	22-10-2020
Project ID	850
Monitoring Period	21-08-2012 to 20-07-2018
Prepared By	Siran Wu
Contact	Block B, Level 24, Jiangong Mansion, 33 Fushan Road, Pudong New Area, Shanghai, P.R. of China Telephone: 2162462036; Email: wu.siran@climatebridge.com http://www.climatebridge.com

CONTENTS

- 1 PROJECT DETAILS..... 3**
 - 1.1 Summary Description of the Implementation Status of the Project3
 - 1.2 Sectoral Scope and Project Type3
 - 1.3 Project Proponent3
 - 1.4 Other Entities Involved in the Project4
 - 1.5 Project Start Date4
 - 1.6 Project Crediting Period4
 - 1.7 Project Location4
 - 1.8 Title and Reference of Methodology6
 - 1.9 Participation under other GHG Programs.....6
 - 1.10 Other Forms of Credit.....6
 - 1.11 Sustainable Development.....6

- 2 SAFEGUARDS..... 7**
 - 2.1 No Net Harm7
 - 2.2 Local Stakeholder Consultation7
 - 2.3 AFOLU-Specific Safeguards8

- 3 IMPLEMENTATION STATUS 8**
 - 3.1 Implementation Status of the Project Activity8
 - 3.2 Deviations9
 - 3.3 Grouped Projects9

- 4 DATA AND PARAMETERS..... 9**
 - 4.1 Data and Parameters Available at Validation9
 - 4.2 Data and Parameters Monitored.....10
 - 4.3 Monitoring Plan.....20

- 5 QUANTIFICATION OF GHG EMISSION REDUCTIONS AND REMOVALS 25**
 - 5.1 Baseline Emissions25
 - 5.2 Project Emissions27
 - 5.3 Leakage.....27
 - 5.4 Net GHG Emission Reductions and Removals.....27

1 PROJECT DETAILS

1.1 Summary Description of the Implementation Status of the Project

Inner Mongolia Jingneng Saihan Wind Farm Phase I Project (hereafter referred as the Project) located in Saihantala Town, Suniteyou Qi, Xilinhot City, Xilinguole League, Inner Mongolia Autonomous Region, People’s Republic of China. The objective of the Project is to utilize wind resources for electricity generation. The Project involves the installation of 30 wind turbines with each capacity of 750 kW and 18 wind turbines with each capacity of 1500 kW, and totals up an installation capacity of 49.5MW. The estimated annual electricity supplied to NCPG from the project is 124,497MWh. The electricity supplied by the Project is sold to West Inner Mongolia Power Grid, which is an integral part of the North China Power Grid. The Project helps reduce GHG emissions generated from the high-growth, coal-dominated power generation.

The construction of the project was started on 10/06/2008. The first wind turbine of the Project has been put into operation on 31/12/2008, and all the 48 wind turbines have been put into operation on 15/05/2009. The expected technical lifetime of the Project is 20 years.

During this VCS monitoring period from 21/08/2012-20/07/2018 the total emission reduction achieved is 635,270 tCO_{2e}.

1.2 Sectoral Scope and Project Type

Sectoral scope: 1. Energy (renewable/non-renewable);

Project type: Wind-power generation project;

The project is not a grouped project.

1.3 Project Proponent

Organization name	Beijing International New Energy Co., Ltd.
Contact person	Jiaman Xu
Title	Project Manager
Address	No.1, Nanbinhe Road, Guanganmenwai, Xuanwu District, 1003 Room, Gaoxin Building, Beijing City, China.
Telephone	021-23019950
Email	1169735462@qq.com

1.4 Other Entities Involved in the Project

Organization name	Climate Bridge Ltd.
Role in the Project	VCU Buyer
Contact person	Zhiwen Gao
Title	General Manager
Address	Block B, Level 24, Jiangong Mansion, 33 Fushan Road, Pudong New Area, Shanghai, China 200120
Telephone	+86-2162462036
Email	gao.zhiwen@climatebridge.com

1.5 Project Start Date

The project started on 31/12/2008 when the first wind turbine of the wind farm has been in operation.

1.6 Project Crediting Period

There is a deviation for the crediting period. The project is registered under VCS 3 and completed validation before 19/03/2020, thus it remains eligible to apply the crediting period requirements under VCS version 03 which shall be a maximum of ten years and may be renewed at most twice. As the first wind turbine of the wind farm has been in operation since 31/12/2008, the project entity only requests VCUs generated by the project from 01/01/2009, so the first renewable crediting period of the project shall be updated from 01/01/2009 ~28/02/2010 to 01/01/2009 ~31/12/2018.

1.7 Project Location

The Project located in Saihantala Town, Suniteyou Qi, Xilinhot City, Xilinguole League, Inner Mongolia Autonomous Region, People's Republic of China. The geographical coordinates of the project are east longitude of 112° 49'36.88" and north latitude of 42° 34'23.24".



Figure 1. Location of Inner Mongolia Autonomous Region in China



Figure 2. Location of the project

1.8 Title and Reference of Methodology

The selected methodology:

The approved methodology applied in the project activity is ACM0002 (version 07) – “Consolidated methodology for grid-connected electricity generation from renewable sources”.

“Tool for the Demonstration and Assessment of Additionality (version 05.2)” and “Tool to calculate the emission factor for an electricity system (version 01.1)” are also applied in the proposed project.

For more information regarding the methodologies please refer to

<http://cdm.unfccc.int/methodologies/PAMethodologies/approved.html>

1.9 Participation under other GHG Programs

The project has been registered as a Clean Development Mechanism (CDM) project in UNFCCC on 01/03/2010 (UNFCCC Ref. 2567), with the 7 years crediting period started from 01/03/2010. Please refer to the following link for details:

<https://cdm.unfccc.int/Projects/DB/BVQI1241775281.35/view>

1.10 Other Forms of Credit

Total GHG emission reductions of 287,673 tCO₂ generated from 01/03/2010 to 20/08/2012 (both days included) by the project has been issued as CER under CDM program

The GHG emission reductions generated by the project from 21/08/2012 to 20/07/2018 will not be used for compliance with emission trading programs or to meet binding limits on GHG emissions.

All credits from 21/08/2012 to 20/07/2018 will be claimed under VCS program as VCUs for the project to avoid double counting.

The project hasn't sought or received another form of environmental credits.

1.11 Sustainable Development

The project makes contribution to the local sustainable development as follows:

1. GHG emission reduction

The project achieves obvious greenhouse gas (GHG) emission reductions by avoiding CO₂ emissions, as grid-connected fossil fuel-fired power dominates in the NCPG.

2. Pollutants emission reduction through replacing fossil fuel combustion

The project replaces grid-connected fossil fuel-fired power plants in the NCPG, and thus reduces fossil fuel consumption and avoids pollutants emission, such as sulfur dioxide and dust, brought by fossil fuel combustion. Therefore, the project has obvious environmental benefit.

3. Employment opportunities

The conducting of the project offers 16 job opportunities for local people.

4. Economy Improvement

The construction of the wind farm achieves the economy development in the region. Furthermore, the project contributes to local government with more tax revenues and poverty eradication.

2 SAFEGUARDS

2.1 No Net Harm

There are no negative environmental and/or socio-economic impacts due to the project. In fact, the project as a clean renewable energy project can reduce greenhouse gas emissions and the environmental pollution caused by fossil fuels consumption. Meanwhile, the implementation of the project will improve local socio-economic development through creating career opportunities and paying taxes.

2.2 Local Stakeholder Consultation

The project developer has sent out questionnaires to the stakeholders in the local County for the comments of the project construction in 18/03/2008. 50 copies of questionnaire were distributed, and 47 pieces of reply were received. The recovery ratio is 94%. Among the interviewees, there were 9 farmers, 4 workers, 17 government officials, 3 students, 5 teachers and 9 others. 9 of them have educational level of middle school, 19 of high school, 15 of college, 2 of graduate, and 2 of others. The questions regarding the project were mainly as follows:

1. Is the current living and/or working environment quiet?
2. Do you currently experience electromagnetic interference when watching TV at home?
3. Are there any negative impacts of the project on the everyday life of local resident?
4. Is the project going to help to improve the local economic development?
5. Do you think the construction of the project will have any noise impact on the environment?

6. Which is the environmental topic that concerns you the most during the construction and operation of the project?

7. Do you support the project?

The summary of survey is listed as the following:

-70% of them consider their current living and/or working environment is quiet, another 30% is unsure and only one person thinks different;

-75% of them currently do not experience electromagnetic interference when watching TV at home, while other 15% have the experience, and 10% don't know;

-85% of them think there will not be any negative impacts on their everyday life, and the remainder is unsure;

-100% of them think the project will help improve local economics

-62% of them think the construction of the project will have no noise impact on the environment while other 32% is not sure, and three persons think the construction of the project will have noise impact on the environment;

-Regarding the construction and operation of the propose project, 21% of them are most concerned with the noise level, 64% of them are most concerned with electromagnetic interference, and 15% of them are most concerned with wastewater from the project;

-100% of them support the implementation of the project.

2.3 AFOLU-Specific Safeguards

NA

3 IMPLEMENTATION STATUS

3.1 Implementation Status of the Project Activity

The total installed capacity of the project is 49.5 MW, served by 30 wind turbine generators each with a unit capacity of 750kW, and 18 wind turbine generators each with a unit capacity of 1500kW, providing a total installed capacity of 49.5MW. The first wind turbine of the Project has been put into operation on 31/12/2008. And all the 48 wind turbines have been put into operation on 15/05/2009. There was no significant malfunction or any emergency reported for the Project during this VCS monitoring period from 21/08/2012 to 20/07/2018.

The project uses Goldwind S50/750kW and Goldwind 77/1500kW wind turbine generators which are manufactured by Goldwind Science and Technology Co., Ltd. The main technical parameters of the wind turbine generators are shown in Table 1 below.

Table 1. The main technical parameters of the wind turbine generator

Part	Parameters	Parameters
Turbine		
Type	Goldwind S50/750kW	Goldwind 77/1500kW
Quantity	30	18
Rated capacity (kW)	750	1,500
Number of blades	3	3
Rotor diameter (m)	50	77
Swept area (m ²)	1,963.5	4,657
Cut-in speed (m/s)	3.5	3
Rated wind speed (m/s)	14-15	11
Safe wind speed (m/s)	70	59.5
Cut-out speed (m/s)	25	22
Height of tower (m)	50	65
Rated voltage of generator (V)	690	690
Rated capacity of generator (kW)	750	1,500

3.2 Deviations

3.2.1 Methodology Deviations

NA

3.2.2 Project Description Deviations

There is a deviation for the crediting period. The project is registered under VCS 2007.1 and completed validation before 19/03/2020, thus it remains eligible to apply the crediting period requirements under VCS version 3 which shall be a maximum of ten years and may be renewed at most twice, so the first renewable crediting period of the project shall be updated from 01/01/2009 ~28/02/2010 to 01/01/2009 ~31/12/2018(10 years).

3.3 Grouped Projects

The Project is not a grouped project.

4 DATA AND PARAMETERS

4.1 Data and Parameters Available at Validation

In this monitoring report, there is only one parameter $EF_{grid,CM,y}$ available at validation, which is different from the registered PDD. The reason is that the parameter $EF_{grid,CM,y}$ is calculated by the data and parameters available at validation in the registered PDD ($FC_{i,m,y}$, NCV_i , $EF_{CO2,i,y}$, Installed

Capacity, Electricity Generation, Electricity self-consumption ratio, $GENE_{best, coal}$, and $GENE_{best, gas/oil}$). Thus, the only one parameter $EF_{grid, CM, y}$ is simplified in this monitoring report.

Data / Parameter	$EF_{grid, CM, y}$
Data unit	tCO ₂ e/MWh
Description	Baseline emission factor for North China Power Grid
Source of data	Registered CDM PDD
Value applied	1.0549
Justification of choice of data or description of measurement methods and procedures applied	-
Purpose of Data	Calculation of baseline emissions
Comments	The baselines emission factor was determined ex-ante and fixed during the first crediting period.

4.2 Data and Parameters Monitored

The Project shares the 35kV/220kV substation and gateway meters (M1 as the main meter and M2 as the backup meter) with Project B (Inner Mongolia Jingneng Saihan Wind Farm Phase II Project), and other project(s) (Inner Mongolia Jingneng Saihan Wind Farm Phase III Project). In order to deal with the jointly-reading problem, the project owner and the grid company set up the procedure and calculation method to determine the net electricity supplied to the grid by the Project, which is calculated according to the equation (1) in section 4.3.

Data / Parameter	EG_y	
Data unit	MWh	
Description	Net electricity supplied to the Grid by the Project activity in year y	
Source of data	Calculated according to the equation (1) in section 4.3	
Description of measurement methods and procedures to be applied	The net electricity supplied to the Grid by the project is calculated through $EG_{export, y}$, $EG_{import, y}$, $EG_{A, y}$, $EG_{B, y}$, $EG_{C, y}$ and $EG_{im-spares, y}$ according to the equation (1) in section 4.3	
Frequency of monitoring/recording	-	
Value applied	Year	Value
	21/08/2012-31/12/2012	38,430.15
	01/01/2013-31/12/2013	115,699.64

	01/01/2014-31/12/2014	97,365.21
	01/01/2015-31/12/2015	82,909.68
	01/01/2016-31/12/2016	88,737.66
	01/01/2017-31/12/2017	111,076.89
	01/01/2018-20/07/2018	67,992.32
	Total	602,211.54
Monitoring equipment	-	
QA/QC procedures to be applied	Power supplied to the grid is checked by internal verification procedure and electricity sales receipts.	
Purpose of data	Baseline emission calculation	
Calculation method	Calculated according to the equation (1) in section 4.3	
Comments	Uncertainty level of data is low	

Data / Parameter	EG _{export,y}							
Data unit	MWh							
Description	Total electricity supplied to the grid via the main power line by the Project, Project B and other project(s) during year y							
Source of data	Bidirectional electricity meter reading (M1 installed at the Wenduer substation, and M2 as its back up Meter, installed at the high voltage of the 35kV/220kV substation at the Project site)							
Description of measurement methods and procedures to be applied	Continuously measured and monthly recorded. Data are archived for 2 years following the end of the crediting period by means of electronic and paper backup. The accuracy of electricity meter (M1) is 0.2s. The calibration frequency is one time/year in accordance with the national calibration standard							
Frequency of monitoring/recording	Continuously measured and monthly recorded							
Value applied	<table border="1"> <thead> <tr> <th>Year</th> <th>Value</th> </tr> </thead> <tbody> <tr> <td>21/08/2012-31/12/2012</td> <td>77,208.24</td> </tr> <tr> <td>01/01/2013-31/12/2013</td> <td>325,842.43</td> </tr> </tbody> </table>		Year	Value	21/08/2012-31/12/2012	77,208.24	01/01/2013-31/12/2013	325,842.43
Year	Value							
21/08/2012-31/12/2012	77,208.24							
01/01/2013-31/12/2013	325,842.43							

	01/01/2014-31/12/2014	291,608.30	
	01/01/2015-31/12/2015	273,123.41	
	01/01/2016-31/12/2016	260,642.11	
	01/01/2017-31/12/2017	326,152.29	
	01/01/2018-20/07/2018	197,441.76	
	Total	1,752,018.55	
Monitoring equipment		Main meter (M1)	Backup meter (M2)
	Meter Type	ZMQ202C	ZMQ202C
	Accuracy class	0.2S	0.2S
	Serial No.	95303611	95303617
	Calibration frequency	annually	annually
	Serial No.	Calibration Date	Validity
	95303611 95303617	14/06/2012	13/06/2013
		13/06/2013	12/06/2014
		12/06/2014	11/06/2015
		11/06/2015	10/06/2016
10/06/2016		09/06/2017	
09/06/2017		08/06/2018	
08/06/2018		07/06/2019	
QA/QC procedures to be applied	The data is checked by internal verification procedure. The data will be cross checked by sales receipt.		
Purpose of data	Baseline emission calculation		
Calculation method	-		
Comments	The reading from the main meter is first choice. When the main meter is out of order, the reading from the backup meter will be used.		
Data / Parameter	EG _{import,y}		

Data unit	MWh		
Description	Total electricity purchased from the grid by the Project and Project B and other project(s) during year y		
Source of data	Electricity meter reading (M1 installed at the Wenduer substation), and M2 as its back up Meter, installed at the high voltage of the 35kV/220kV substation at the Project site)		
Description of measurement methods and procedures to be applied	Continuously measured and monthly recorded. Data is archived for 2 years following the end of the crediting period by means of electronic and paper backup. The accuracy of electricity meter (M1) is 0.2s. The calibration frequency is one time/year in accordance with the national calibration standard.		
Frequency of monitoring/recording	Continuously measured and monthly recorded		
Value applied	Year	Value	
	21/08/2012-31/12/2012	220.31	
	01/01/2013-31/12/2013	928.32	
	01/01/2014-31/12/2014	1,015.73	
	01/01/2015-31/12/2015	586.07	
	01/01/2016-31/12/2016	556.46	
	01/01/2017-31/12/2017	523.36	
	01/01/2018-20/07/2018	266.67	
	Total	4,096.93	
Monitoring equipment		Main meter (M1)	Backup meter (M2)
	Meter Type	ZMQ202C	ZMQ202C
	Accuracy class	0.2S	0.2S
	Serial No.	95303611	95303617
	Calibration frequency	annually	annually
	Serial No.	Calibration Date	Validity
	95303611 95303617	14/06/2012	13/06/2013
		13/06/2013	12/06/2014
		12/06/2014	11/06/2015

		11/06/2015	10/06/2016
		10/06/2016	09/06/2017
		09/06/2017	08/06/2018
		08/06/2018	07/06/2019
QA/QC procedures to be applied	The data is checked by internal verification procedure. The data will be cross checked by sales receipt.		
Purpose of data	Baseline emission calculation		
Calculation method	-		
Comments	The reading from the main meter is first choice. When the main meter is out of order, the reading from the backup meter will be used.		

Data / Parameter	$EG_{A-i,y}$	
Data unit	MWh	
Description	Quantity of electricity supplied to the grid by Group A-i (i=1,2,3,4) of the Project in year y.	
Source of data	Readings of electricity meters (A-1, A-2, A-3 and A-4 described in section 5.3) installed at the 35kV transmission line of the Project site.	
Description of measurement methods and procedures to be applied	Continuously measured and monthly recorded. Data are archived for 2 years following the end of the last crediting period by means of electronic and paper backup. The accuracy of electricity meters (A-1, A-2, A-3 and A-4) is 0.5s. The calibration frequency is once a year.	
Frequency of monitoring/recording	Continuously measured and monthly recorded.	
Value applied	Year	Value
	21/08/2012-31/12/2012	39,252.43
	01/01/2013-31/12/2013	118,136.04
	01/01/2014-31/12/2014	99,777.27
	01/01/2015-31/12/2015	85,008.40

01/01/2016-31/12/2016	90,709.95
01/01/2017-31/12/2017	108,757.60
01/01/2018-20/07/2018	65,782.63
Total	607,424.33

Monitoring equipment

	Meter A-1	Meter A-2	Meter A-3	Meter A-4
Meter Type	DTSD341	DTSD341	DTSD341	DTSD341
Accuracy class	0.5S	0.5S	0.5S	0.5S
Serial No.	9020390	9020463	9020465	9020392
Calibration frequency	annually	annually	annually	annually

Serial No.	Calibration Date	Validity
9020390 9020463 9020465 9020392	14/06/2012	13/06/2013
	13/06/2013	12/06/2014
	12/06/2014	11/06/2015
	11/06/2015	10/06/2016
	10/06/2016	09/06/2017
	09/06/2017	08/06/2018
	08/06/2018	07/06/2019

QA/QC procedures to be applied

The metering equipments at the 35kV transmission line are calibrated once a year according to the national calibration standard.

Purpose of data

Baseline emission calculation

Calculation method

-

Comments

Uncertainty level of data is low

Data / Parameter	$EG_{B-i,y}$
Data unit	MWh
Description	Quantity of electricity supplied to the grid by Group B-i (i=1,2,3,4)

	of the Project B in year y.				
Source of data	Readings of electricity meters (B-1, B-2, B-3 and B-4 described in section 5.3) installed at the 35kV transmission line of the Project B site.				
Description of measurement methods and procedures to be applied	Continuously measured and monthly recorded. Data are archived for 2 years following the end of the last crediting period by means of electronic and paper backup. The accuracy of electricity meters (B-1, B-2, B-3 and B-4) is 0.5s. The calibration frequency is once a year.				
Frequency of monitoring/recording	Continuously measured and monthly recorded.				
Value applied	Year		Value		
	21/08/2012-31/12/2012		33,005.90		
	01/01/2013-31/12/2013		85,162.55		
	01/01/2014-31/12/2014		86,037.33		
	01/01/2015-31/12/2015		85,842.69		
	01/01/2016-31/12/2016		64,571.84		
	01/01/2017-31/12/2017		72,041.09		
	01/01/2018-20/07/2018		41,389.99		
	Total		468,051.39		
Monitoring equipment		Meter B-1	Meter B-2	Meter B-3	Meter B-4
	Meter Type	DTSD341	DTSD341	DTSD341	DTSD341
	Accuracy class	0.5S	0.5S	0.5S	0.5S
	Serial No.	4690001	4690002	4690003	4690004
	Calibration frequency	annually	annually	annually	annually
		Calibration		Validity	
		Date			
	4690001 4690002 4690003 4690004	14/06/2012		13/06/2013	
		13/06/2013		12/06/2014	
		12/06/2014		11/06/2015	
11/06/2015		10/06/2016			

		10/06/2016	09/06/2017
		09/06/2017	08/06/2018
		08/06/2018	07/06/2019
QA/QC procedures to be applied	The metering equipments at the 35kV transmission line are calibrated once a year according to the national calibration standard.		
Purpose of data	Baseline emission calculation		
Calculation method	-		
Comments	Uncertainty level of data is low		

Data / Parameter	$EG_{C-i,y}$	
Data unit	MWh	
Description	Quantity of electricity supplied to the grid by Group C-i (i=1,2,...,n) of other project(s) in year y.	
Source of data	Readings of electricity meters (C-1, C-2...C-i described in section 5.3) installed at the 35kV transmission line of the other project(s) site.	
Description of measurement methods and procedures to be applied	Continuously measured and monthly recorded. Data are archived for 2 years following the end of the last crediting period by means of electronic and paper backup. The accuracy of electricity meters (C-1, C-2...C-i) will be not lower than 0.5s. The calibration frequency is once a year.	
Frequency of monitoring/recording	Continuously measured and monthly recorded.	
Value applied	Year	Value
	21/08/2012-31/12/2012	6,124.80
	01/01/2013-31/12/2013	126,660.71
	01/01/2014-31/12/2014	109,744.20
	01/01/2015-31/12/2015	107,080.61
	01/01/2016-31/12/2016	109,336.59
	01/01/2017-31/12/2017	136,950.31
	01/01/2018-20/07/2018	83,074.59

	Total	678,971.82			
Monitoring equipment		Meter C-1	Meter C-2	Meter C-3	Meter C-4
	Meter Type	DTSD341	DTSD341	DTSD341	DTSD341
	Accuracy class	0.5S	0.5S	0.5S	0.5S
	Serial No.	2873616	2873617	2873618	2873619
	Calibration frequency	annually	annually	annually	annually
		Serial No.	Calibration Date		Validity
		2873616 2873617 2873618 2873619	14/06/2012		13/06/2013
			13/06/2013		12/06/2014
			12/06/2014		11/06/2015
			11/06/2015		10/06/2016
	10/06/2016		09/06/2017		
	09/06/2017		08/06/2018		
	08/06/2018		07/06/2019		
QA/QC procedures to be applied	The metering equipments at the 35kV transmission line are calibrated once a year according to the national calibration standard.				
Purpose of data	Baseline emission calculation				
Calculation method	-				
Comments	Other project(s) are under construction and may share the 35kV/220kV substation at the Project site and the gateway meters at Wenduer substation with the Project and Project B. After it is connected to the Project and put into operation, the parameter should be monitored.				

Data / Parameter	$EG_{im-spare,y}$
Data unit	MWh
Description	Total electricity purchased from the grid by the Project, Project B and Other project(s) through a spare 10 kV line in the year y.

Source of data	Electricity meter reading (M3 installed on the spare 10 kV line)																											
Description of measurement methods and procedures to be applied	The local power distributor will measure the $EG_{im-spare,y}$ by metering instrument owned, operated and installed by local power distributor. Only the owner is accessible to the meter. Electricity sales receipts will be issued accordingly in an approach which is agreed by both local power distributor and the project owner. The accuracy of the meter M3 is 2.0. The calibration frequency is once a year																											
Frequency of monitoring/recording	Continuously measured and monthly recorded.																											
Value applied	<table border="1"> <thead> <tr> <th>Year</th> <th>Value</th> </tr> </thead> <tbody> <tr> <td>21/08/2012-31/12/2012</td> <td>13.61</td> </tr> <tr> <td>01/01/2013-31/12/2013</td> <td>34.11</td> </tr> <tr> <td>01/01/2014-31/12/2014</td> <td>62.68</td> </tr> <tr> <td>01/01/2015-31/12/2015</td> <td>41.98</td> </tr> <tr> <td>01/01/2016-31/12/2016</td> <td>52.78</td> </tr> <tr> <td>01/01/2017-31/12/2017</td> <td>33.59</td> </tr> <tr> <td>01/01/2018-20/07/2018</td> <td>11.33</td> </tr> <tr> <td>Total</td> <td>250.09</td> </tr> </tbody> </table>		Year	Value	21/08/2012-31/12/2012	13.61	01/01/2013-31/12/2013	34.11	01/01/2014-31/12/2014	62.68	01/01/2015-31/12/2015	41.98	01/01/2016-31/12/2016	52.78	01/01/2017-31/12/2017	33.59	01/01/2018-20/07/2018	11.33	Total	250.09								
Year	Value																											
21/08/2012-31/12/2012	13.61																											
01/01/2013-31/12/2013	34.11																											
01/01/2014-31/12/2014	62.68																											
01/01/2015-31/12/2015	41.98																											
01/01/2016-31/12/2016	52.78																											
01/01/2017-31/12/2017	33.59																											
01/01/2018-20/07/2018	11.33																											
Total	250.09																											
Monitoring equipment	<table border="1"> <tr> <td></td> <td>Meter M3</td> </tr> <tr> <td>Meter Type</td> <td>DS862-4</td> </tr> <tr> <td>Accuracy class</td> <td>2.0</td> </tr> <tr> <td>Serial No.</td> <td>10669106</td> </tr> <tr> <td>Calibration frequency</td> <td>annually</td> </tr> </table> <table border="1"> <thead> <tr> <th>Serial No.</th> <th>Calibration Date</th> <th>Validity</th> </tr> </thead> <tbody> <tr> <td rowspan="6">10669106</td> <td>14/06/2012</td> <td>13/06/2013</td> </tr> <tr> <td>13/06/2013</td> <td>12/06/2014</td> </tr> <tr> <td>12/06/2014</td> <td>11/06/2015</td> </tr> <tr> <td>11/06/2015</td> <td>10/06/2016</td> </tr> <tr> <td>10/06/2016</td> <td>09/06/2017</td> </tr> <tr> <td>09/06/2017</td> <td>08/06/2018</td> </tr> </tbody> </table>			Meter M3	Meter Type	DS862-4	Accuracy class	2.0	Serial No.	10669106	Calibration frequency	annually	Serial No.	Calibration Date	Validity	10669106	14/06/2012	13/06/2013	13/06/2013	12/06/2014	12/06/2014	11/06/2015	11/06/2015	10/06/2016	10/06/2016	09/06/2017	09/06/2017	08/06/2018
	Meter M3																											
Meter Type	DS862-4																											
Accuracy class	2.0																											
Serial No.	10669106																											
Calibration frequency	annually																											
Serial No.	Calibration Date	Validity																										
10669106	14/06/2012	13/06/2013																										
	13/06/2013	12/06/2014																										
	12/06/2014	11/06/2015																										
	11/06/2015	10/06/2016																										
	10/06/2016	09/06/2017																										
	09/06/2017	08/06/2018																										

		08/06/2018	07/06/2019
QA/QC procedures to be applied	Reading recording, operation and maintenance of this meter was implemented by local power distributor (the owner of the metering instrument). The data will be cross checked by sales receipt.		
Purpose of data	Baseline emission calculation		
Calculation method	-		
Comments	Uncertainty level of data is low		

4.3 Monitoring Plan

The monitoring plan of the project is designed according to the approved consolidated monitoring methodology ACM0002 “Grid-connected electricity generation from renewable sources” (version 07). This monitoring plan sets out a number of monitoring tasks in order to ensure the complete, consistent, clear and accurate monitoring and the accurate calculation of the emission reduction in the crediting period. This plan is mainly implemented by the project owner with the cooperation of the grid company.

1. Monitoring Object

The main objective data is the power supplied to and purchased from the grid, which is calculated according to the generated electricity and the purchased electricity and supplied to the grid, thus to calculate the emission reduction of the project.

2. Monitoring Implementers

The General Manager of the project entity appoints a VCS project manager or a chief officer. The operational and monitoring manager of the plant, the Financial Chief, and the Technical Chief are responsible for the collection of the data and information required in the monitoring plan. The collected information is documented and sent to the VCS manager or responsible staffs of the project entity monthly. The VCS manager in charge of the implementation of the Monitoring Plan and report to the General Manager of the company. The General Manager of the company makes the confirmations on monitoring, calculation data and reports.

The organization of the monitoring implementers is illustrated in the table below:

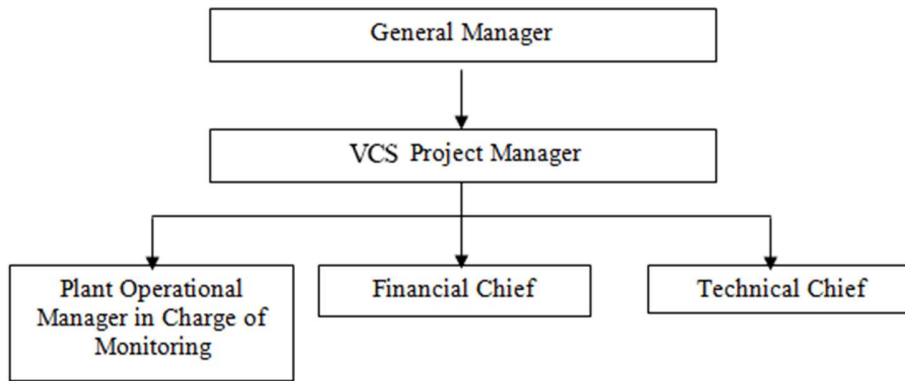

Figure 3: Monitoring structure of the project

3. Monitoring Program and Equipment

The power connection and monitoring system is shown as below:

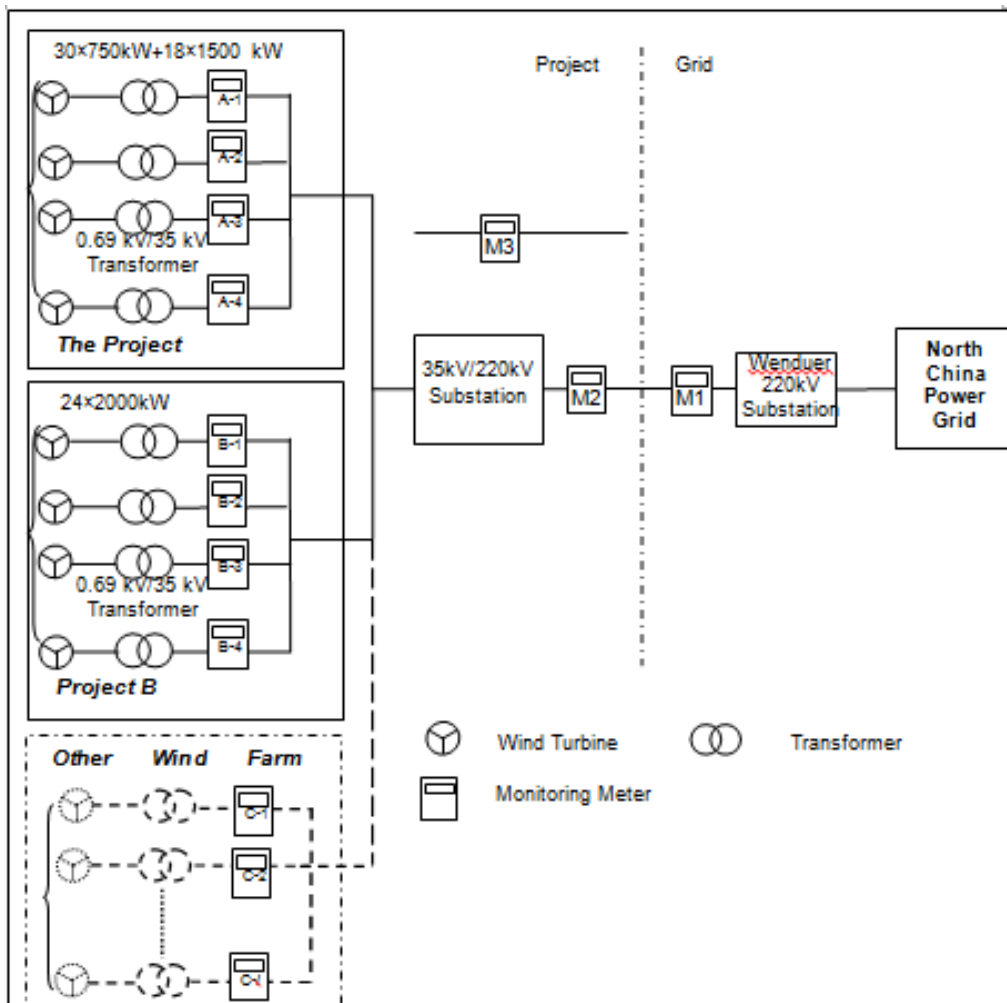

Figure 4: The location of meters

The Project shares the 35kV/220kV substation and gateway meters (M1 as the main meter and M2 as the backup meter) with Project B (Inner Mongolia Jingneng Saihan Wind Farm Phase II Project), and other project(s) (so called other project(s), of which Inner Mongolia Jingneng Saihan Wind Farm Phase III Project is in operation on 14/12/2012¹, and other more projects will be planed for construction) which are under construction and will be connected to the 35kV/220kV substation. Before other project(s) puts into operation, monitoring equipment include M1, M2, M3, A-1, A-2, A-3, A-4, B-1, B-2, B-3 and B-4; After other project(s) puts into operation, C-1, C-2...C-i will be included in the monitoring equipment.

The main meter M1 is employed at the grid company substation and the grid company is responsible for conducting the monitoring. The backup meter M2 is equipped at the high voltage of the 35kV/220kV substation at the Project site and the project owner is responsible for conducting its monitoring. The accuracy of the meters M1 and M2 is 0.2s. At the same time, the data measured by M1 and M2 can be monitored and recorded at the on-site control centre using a computer system.

Additionally, a spare 10 kV line is used for supplying electricity to the Project, Project B and Other project(s) in emergencies. $E_{G_{im-spare,y}}$ is measured by the meter M3 which is owned, operated and installed by local power distributor. Sales receipt will be cross-check with the meter reading. The accuracy of M3 is 2.0, which meets the national requirement. The calibration will be done in line with the national calibration standard.

The 48 sets of wind turbines of the Project were divided into 4 groups, and each group is connected with a 35kV transmission line and installed with a meter at the low voltage side of 35kV/220kV substation. These meters (A-1, A-2, A-3, A-4) are installed as the auxiliary meters to calculate the electricity supplied to the grid by Group A-i (i=1,2,3,4) of the Project. Similarly, Four meters (B-1, B-2, B-3, B-4) are installed as auxiliary meters to calculate the electricity supplied to the grid by Group B-i (i=1,2,3,4) of the Project B. The accuracy of these eight meters is 0.5s.

Moreover, considering there are other wind farm project(s) (so called other project(s), of which currently Inner Mongolia Jingneng Saihan Wind Farm Phase III Project is in operation, and other more projects will be planed for construction) , will share the 35kV/220kV substation on the Project site, the gateway meters (M1 and M2) in Wenduer 220kV substation and the M3 on a 10kV spare line, more meters (C-1, C-2,...C-i) will be installed on the 35kV transmission line at the other project(s) site to monitor the supplied electricity by other project(s). The accuracy of these meters (C-1, C-2...C-i) will be no lower than 0.5s and they will be calibrated in accordance with national standards.

In order to deal with the jointly-reading problem, the project owner and the grid company set up the procedure and calculation method to determine the net electricity supplied to the grid by the Project, which is calculated as follows:

¹ Inner Mongolia Jingneng Saihan Wind Farm Phase III Project quality supervision and inspection reports

$$EG_{facility,y} = \frac{EG_{A-i,y}}{EG_{A-i,y} + EG_{B-i,y} + EG_{C-i,y}} EG_{export,y} - EG_{import,y} - EG_{im-spare,y} \quad (1)$$

Where:

$EG_{facility,y}$	=	Quantity of net electricity generation that is produced and fed into the grid as a result of the implementation of the Project activity in year y
$EG_{export,y}$	=	Total electricity supplied to the grid via the main power line by the Project, Project B and other project(s) in the year y.
$EG_{import,y}$	=	Total electricity purchased from the grid via the main power line by the Project, Project B and other project(s) in the year y.
$EG_{A-i,y}$	=	Electricity supplied to the grid by Group A-i (i=1,2,3,4) of the Project in the year y.
$EG_{B-i,y}$	=	Electricity supplied to the grid by Group B-i (i=1,2,3,4) of the Project B in the year y.
$EG_{C-i,y}$	=	Electricity supplied to the grid by Group C-i (i=1,2...n) of the other project(s) in the year y.
$EG_{im-spare,y}$	=	Total electricity purchased from the grid by the Project, Project B and other project(s) through the spare 10 kV line in the year y.

4. Data Collection

Before other project(s) are connected to the 35kV/220kV substation at the Project site, the verification use the data of the main meter M1, the meter M3 installed on the spare 10 kV line and eight auxiliary meters on 35kV transmission line as long as the inaccuracy of these meters is within the permissible tolerance. The main procedures are as follows:

- 1) According to the requirements of power purchase/sales agreement, the project owner and the grid company should collect the data of both the main meter M1 and the backup meter M2 periodically, and check them at the same time.
- 2) For the electricity supplied to the grid by the project activity, the project owner collects and records the data of auxiliary meters and calculates the electricity supplied to the grid by the Project as per the procedure and calculation method jointly set up. Then the project owner provides sales receipt to the Grid Company. A copy of the sales receipt is stored for cross-check.
- 3) When the electricity generated by this project cannot meet the electricity requirement of the power plant, the grid company supplies the electricity to the project owner. The Grid Company provides an electricity sales receipt to the project owner and the sales receipt is stored by the project owner.
- 4) The project owner records the power supplied to and purchased from the grid as well as the electricity purchased from the spare 10 kV line, and hence calculate the net electricity supplied to the grid;

- 5) The project owner will keep the records of the main meter, the meter installed on the spare 10 kV line and the eight auxiliary meters' data readings for verification by the DOE.

In any case that any of the eight auxiliary meters on 35kV transmission line exceeds the allowable tolerance or its malfunction occurs, the project owner will give up the emission reductions during the period when any of the eight auxiliary meters are inaccurate. Otherwise, if the fault of the main meter M1 exceeds the allowable tolerance or its malfunction occurs but the eight auxiliary meters are within the allowable tolerance, the grid-connected electricity generated by the Project will be resolved by following measures:

- 1) Adopting the backup meter M2, the meter M3 installed on the spare 10 kV line and the eight auxiliary meters' data, unless a test by either party reveals it is inaccurate;
- 2) If the inaccuracy of the backup meter M2 is not within the acceptable limits or it cannot work properly, the project owner will give up the emission reductions during the period when both the main meter and the backup meter are inaccurate;

In addition, in any case that the fault of the meter M3 installed on the spare 10 kV line exceeds the allowable tolerance or its malfunction occurs, to be conservative, the project owner will apply the largest data over the years to calculate the emission reductions.

After the other project(s) connects to the shared 35kV/220kV substation at the Project site, the collection procedures of the data measured by the meter (C-1, C-2,...C-i) are similar to the above procedures of the Project and Projects B. If any meter (C-1, C-2,...C-i) exceeds the allowable tolerance or its malfunction occurs, the project owner will give up the emission reductions during the period when any of the meters (C-1, C-2,...C-i) are in malfunction.

5. Calibration of Meters & Metering

The metering equipment will be properly calibrated and checked annually for accuracy. The project owner will prepare backup procedures to deal with any errors occurred to the meters. The calibration records carried out by the grid company should be provided to the project owner, and these records will be maintained by the project owner and the third party designated.

Meters should be tested by a qualified metric organization co-authorized by the project owner and the grid company within 10 days after:

- 1) The detection of the reading difference between the main meter and the backup meter that exceeds the allowable tolerance.
- 2) The equipment's malfunction caused by improper operation

All the calibration test records should be maintained safely for the verification.

6. Data Management System

To keep safely the record of the data collected during monitoring, this project will set up a complete data management system. The project will perfect the whole monitoring procedure by

developing the VCS manual, tracking information from the primary source to the end-data calculations in paper document format. It is the responsibility of the project owner to provide additional necessary data and information for validation and verification requirements of respective DOE. Physical documentation such as paper-based maps, diagrams and environmental assessment will be collated in a central place, together with this monitoring plan. All paper-based information will be stored by the project owner and kept at least one copy.

At the end of each month, the monitoring data will be filed in a spreadsheet, and the paper-based printout should be also archived. Furthermore, the project owner collects the sales receipts for the electricity supplied to the grid as a cross-check, and compiled the monitoring report including the monitoring data and relevant evidence at the end of each crediting year.

All the data will be kept for two years following the end of the last crediting period.

7. Monitoring Report

After the VCS project manager collects and sorts the monitored data, the monitoring report is prepared by the project developer. The project developer has to make sure that the format and content of the monitoring report are consistent with the monitoring methodology in the registered PD.

5 QUANTIFICATION OF GHG EMISSION REDUCTIONS AND REMOVALS

5.1 Baseline Emissions

According to the registered PDD, the baseline emissions are calculated as the electricity supplied by the project activity to the grid ($EG_{\text{facility}, y}$ in MWh) times the combined margin emission factor ($EF_{\text{grid}, \text{CM}, y}$ in tCO_2/MWh) as follows:

$$BE_y = EG_y \times EF_{\text{grid}, \text{CM}, y} \quad (2)$$

Where:

BE_y	Baseline emissions in year y (tCO_2e)
EG_y	Net electricity supplied to the grid by the Project in the year y
$EF_{\text{grid}, \text{CM}, y}$	Combined margin CO_2 emission factor for grid connected power generation in year y calculated using the latest version of the "Tool to calculate the emission factor for an electricity system" ($\text{tCO}_2\text{e}/\text{MWh}$)

Net electricity supplied to the grid by the Project in the year y (EG_y) in this monitoring period (21/08/2012-20/07/2018) as in the table below:

Table E-1 Quantity of net electricity supplied to the grid during the Monitoring Period

Period	EG _{export,y} (MWh)			EG _{import,y} (MWh)			EG _{im-epare,y} (MWh)			EG _{A-1,y} (MWh)	EG _{B-1,y} (MWh)	EG _{C-1,y} (MWh)	EG _y (MWh)
	Invoice of electricity sales	Measured by the meter	Conservative value	Invoice of electricity sales	Measured by the meter	Conservative value	Invoice of electricity sales	Measured by the meter	Conservative value	Measured by the meter	Measured by the meter	Measured by the meter	
21/08/2012 - 31/12/2012	77,208.24	77,208.24	77,208.24	220.31	220.31	220.31	13.61	13.61	13.61	39,252.43	33,005.90	6,124.80	38,430.15
01/01/2013 - 31/12/2013	325,842.43	325,842.43	325,842.43	928.32	928.32	928.32	34.11	34.11	34.11	118,136.04	85,162.55	126,660.71	115,699.64
01/01/2014 - 31/12/2014	291,608.30	291,608.30	291,608.30	1,015.73	1,015.73	1,015.73	62.68	62.68	62.68	99,777.27	86,037.33	109,744.20	97,365.21
01/01/2015 - 31/12/2015	273,123.41	273,123.41	273,123.41	586.07	586.07	586.07	41.98	41.98	41.98	85,008.40	85,842.69	107,080.61	82,909.68
01/01/2016 - 31/12/2016	260,642.11	260,642.11	260,642.11	556.46	556.46	556.46	52.78	52.78	52.78	90,709.95	64,571.84	109,336.59	88,737.66
01/01/2017 - 31/12/2017	326,152.29	326,152.29	326,152.29	523.36	523.36	523.36	33.59	33.59	33.59	108,757.60	72,041.09	136,950.31	111,076.89
01/01/2018 - 20/07/2018	197,441.76	197,441.76	197,441.76	266.67	266.67	266.67	11.33	11.33	11.33	65,782.63	41,389.99	83,074.59	67,992.32
Total	1,752,018.55	1,752,018.55	1,752,018.55	4,096.93	4,096.93	4,096.93	250.09	250.09	250.09	607,424.33	468,051.39	678,971.82	602,211.54

Among which, $EF_{grid,CM,y}$ is 1.0549 tCO₂/MWh in the first crediting period, therefore, the Baseline Emission is:

$$BE_y = EG_y * EF_{grid,CM,y} = 635,270 \text{ tCO}_2$$

5.2 Project Emissions

According to ACM0002, no project emissions were to be counted by the Project.

Hence, $PE_y=0$.

5.3 Leakage

According to the ACM0002, no leakage emissions are considered

5.4 Net GHG Emission Reductions and Removals

According to the Section 5.1, 5.2 and 5.3 above,

$$BE_y = 635,270 \text{ tCO}_2\text{e};$$

$$PE_y = 0 \text{ tCO}_2\text{e};$$

$$LE_y = 0 \text{ tCO}_2\text{e};$$

Therefore, $ER_y = BE_y - PE_y - LE_y = 635,270 \text{ tCO}_2\text{e}$

This monitoring period started from 21/08/2012 to 20/07/2018, with totally 2,160 days. Based on the annual estimated emission reductions from the registered CDM PDD, the amount of emission reductions for this monitoring period would be $131,331 \text{ tCO}_2\text{e}/365\text{d} \times 2,160\text{d} = 777,191 \text{ tCO}_2\text{e}$. The actual emission reductions in this monitoring period (2,160 days) are 635,270 tCO₂e, which is 18.26% less than the estimation in the registered PDD.

Year	Baseline emissions or removals (tCO ₂ e)	Project emissions or removals (tCO ₂ e)	Leakage emissions (tCO ₂ e)	Net GHG emission reductions or removals (tCO ₂ e)
21/08/2012-31/12/2012	40,539	0	0	40,539
01/01/2013-31/12/2013	122,051	0	0	122,051
01/01/2014-31/12/2014	102,710	0	0	102,710

01/01/2015-31/12/2015	87,461	0	0	87,461
01/01/2016-31/12/2016	93,609	0	0	93,609
01/01/2017-31/12/2017	117,175	0	0	117,175
01/01/2018-20/07/2018	71,725	0	0	71,725
Total	635,270	0	0	635,270