



**Verified Carbon
Standard**

INNER MONGOLIA JINGNENG SAIHAN WIND FARM PHASE II PROJECT



Document Prepared by Climate Bridge (Shanghai) Ltd.

Tel: +86 21 6246 2036; Fax: +86 21 2301 9950

Project Title	Inner Mongolia Jingneng Saihan Wind Farm Phase II Project
Version	2.1
Date of Issue	30-12-2020
Prepared By	Siran Wu
Contact	Block B, Level 24, Jiangong Mansion, 33 Fushan Road, Pudong New Area, Shanghai, P.R. of China Telephone: 2162462036; Email: wu.siran@climatebridge.com http://www.climatebridge.com

CONTENTS

- 1 PROJECT DETAILS..... 4**
 - 1.1 Summary Description of the Project 4
 - 1.2 Sectoral Scope and Project Type 4
 - 1.3 Project Eligibility 4
 - 1.4 Project Design 5
 - 1.5 Project Proponent 5
 - 1.6 Other Entities Involved in the Project 5
 - 1.7 Ownership..... 5
 - 1.8 Project Start Date 6
 - 1.9 Project Crediting Period 6
 - 1.10 Project Scale and Estimated GHG Emission Reductions or Removals 6
 - 1.11 Description of the Project Activity 7
 - 1.12 Project Location 8
 - 1.13 Conditions Prior to Project Initiation 10
 - 1.14 Compliance with Laws, Statutes and Other Regulatory Frameworks 10
 - 1.15 Participation under Other GHG Programs 11
 - 1.16 Other Forms of Credit..... 11
 - 1.17 Additional Information Relevant to the Project 12

- 2 SAFEGUARDS..... 12**
 - 2.1 No Net Harm 12
 - 2.2 Local Stakeholder Consultation 13
 - 2.3 Environmental Impact 14
 - 2.4 Public Comments 15
 - 2.5 AFOLU-Specific Safeguards 15

3	APPLICATION OF METHODOLOGY	16
3.1	Title and Reference of Methodology	16
3.2	Applicability of Methodology	16
3.3	Project Boundary	22
3.4	Baseline Scenario	24
3.5	Additionality	25
3.6	Methodology Deviations	25
4	QUANTIFICATION OF GHG EMISSION REDUCTIONS AND REMOVALS	26
4.1	Baseline Emissions	26
4.2	Project Emissions	34
4.3	Leakage.....	34
4.4	Net GHG Emission Reductions and Removals.....	34
5	MONITORING	35
5.1	Data and Parameters Available at Validation	36
5.2	Data and Parameters Monitored.....	38
5.3	Monitoring Plan.....	43

1 PROJECT DETAILS

1.1 Summary Description of the Project

Inner Mongolia Jingneng Saihan Wind Farm Phase II Project (hereinafter referred to as the project) operates a 48 MW grid connected wind farm. The electricity generated from the project is supplied to the North China Power Grid. By replacing the electricity generated from fossil fuel-fired power plants dominated North China Power Grid (NCPG), the project activity achieves obvious greenhouse gas (GHG) emission reductions by avoiding CO₂ emissions.

The purpose of the project is to generate renewable wind power and deliver it to North China Power Grid. For the project,

Prior to the start of implementation of the project activity, there is no power generation unit at the site of the project, and the electricity was supplied by the North China Power Grid which was dominated by fossil fuel-fired power plants.

The project scenario is the implementation of the project, the installation and operation of 24 sets of wind turbines with a total capacity of 48 MW which will supply an average annual generation of 118,560 MWh to North China Power Grid and replace the same amount of electricity generated by fossil fuel-fired power plants connected to North China Power Grid.

The baseline scenario of the project is the electricity supply of equal amount as the project from the North China Power Grid. The baseline scenario of the project is the same against the scenario prior to the start of the implementation of the project activity.

The project located in Suniteyouqi, Xilinguole League, Inner Mongolia Autonomous Region, P. R. China. The project involves the installation of 24 wind turbines with capacity of 2000 kW each, which amount to a total installed capacity of 48 MW, the construction of the project was started on 20/06/2009. The project is invested by Beijing International New Energy Co., Ltd. The second crediting period is 2019/10/27 to 2029/10/26. The estimated average annual emission reductions of the project is 99,643 CO₂e.

1.2 Sectoral Scope and Project Type

Sectoral Scope: 01 Energy industries (renewable - / non- renewable sources).

Project type: Wind power generation project.

1.3 Project Eligibility

The project is not a grouped project.

1.4 Project Design

NA

1.5 Project Proponent

Organization name	Beijing International New Energy Co., Ltd
Contact person	Jiaman Xu
Title	Project Manager
Address	No.1, Nanbinhe Road, Guanganmenwai, Xuanwu District, 1003 Room, Gaoxin Building, Beijing City, China.
Telephone	021-23019950
Email	1169735462@qq.com

1.6 Other Entities Involved in the Project

Organization name	Climate Bridge Ltd.
Role in the project	project participant
Contact person	Zhiwen Gao
Title	General Manager
Address	Block B, Level 24, Jiangong Mansion, 33 Fushan Road, Pudong New Area, Shanghai, China 200120
Telephone	+86-2162462036
Email	gao.zhiwen@climatebridge.com

1.7 Ownership

The project proponent is Beijing International New Energy Co., Ltd. who has the full ownership of the project. The approval of Environmental Impact Assessment (EIA), Preliminary Design Report (PDR), and Letter of Approval for the Project as a CDM Project issued by China National Development and Reform Commission, and the business license of the project owner are evidences for legislative right. Besides, the equipment purchasing contract and the purchasing

power agreement are the evidences for the ownership of the plant, equipment and power generating.

1.8 Project Start Date

The starting date of the project is 27/10/2009 (the date of project started operation).

1.9 Project Crediting Period

There is a deviation for the crediting period. The project is registered under VCS 3 and completed validation before 19/03/2020, thus it remains eligible to apply the crediting period requirements under VCS Version 3 which shall be a maximum of ten years and may be renewed at most twice, so the first renewable crediting period of the project shall be updated from 27/10/2009~08/06/2011 to 27/10/2009~26/10/2019. And the second crediting period is from 27/10/2019 to 26/10/2029 accordingly.

1.10 Project Scale and Estimated GHG Emission Reductions or Removals

Project Scale	
Project	✓
Large project	

Year	Estimated GHG emission reductions or removals (tCO ₂ e)
27/10/2019-26/10/2020	99,643
27/10/2020-26/10/2021	99,643
27/10/2021-26/10/2022	99,643
27/10/2022-26/10/2023	99,643
27/10/2023-26/10/2024	99,643
27/10/2024-26/10/2025	99,643
27/10/2025-26/10/2026	99,643
27/10/2026-26/10/2027	99,643
27/10/2027-26/10/2028	99,643

27/10/2028-26/10/2029	99,643
Total estimated ERs	99,6430
Total number of crediting years	10
Average annual ERs	99,643

1.11 Description of the Project Activity

The project involves the installation of 24 wind turbines with capacities of 2000 kW each, which amount to a total installed capacity of 48MW. The annual net electricity output is 118,560MWh. The annual operation hours of the project are 2,470 hours, thus the plant load factor of the project is 0.28 ($=2,470h/(24h/d*365d)$). The wind turbines were supplied by Beijing Beizhong Steam Turbine Generator Co., Ltd. And the selected model is FD80-2000. The main technical specifications of the wind turbine are provided in the following table.

Table 1 The main technical specification

Item	Unit	Index
Rated capacity	kW	2000
Number of blades	piece	3
Rotor diameter	m	80
Rated wind speed	m/s	13.5
Rated Power	kW	2000
Rated voltage	V	690
Life time	Year	20
Plant load Factor	-	0.28

The project shares the 35kV/220kV substation with Inner Mongolia Jingneng Saihan Wind Farm Phase I Project (referred to as Project B, Ref.850), and other wind farm projects (referred to as other project(s)) which are under construction will be connected to the 35kV/220kV substation at the Project site. The wind power generated are switched by the shared 35kV/220 kV substation through 4 groups of 35kV transmission lines of each project, and then connected to the 220 kV Wenduer substation, and then transmitted to the North China Power Grid finally (see following diagram in section 5.3).

Electricity supplied to the grid by the project activity are directly monitored by the meters (A-1, A-2, A-3 and A-4), which installed at the connection point between the project and the 35kV/220kV substation. And the meters (B-1, B-2, B-3 and B-4) are installed between Project B and the 35kV/220kV substation to monitor the electricity supplied to the grid by Project B. Other meters (C- 1, C-2...C-i) will be installed between other project(s) and the 35kV/220kV substation to monitor the electricity supplied to the grid by other project(s). The location of the meters and the transmission lines are displayed as diagram in section 5.3 for details.

This is a Greenfield wind power plant and there are no facilities, systems and equipment in operation under the existing scenario prior to the implementation of the project activity. The baseline scenario is the continuation of the existing scenario prior to the implementation of the project activity.

The project uses wind turbines manufactures by domestic supplier and there is no international technology transfer involved

1.12 Project Location

The project located in Suniteyouqi, Xilinguole League, Inner Mongolia Autonomous Region, P. R. China. The project has central geographical coordinates with east longitude of 112° 51'00" and north latitude of 42° 37'00". The figure A1 shows the location of Inner Mongolia Autonomous Region, figure 1 shows the location of the Project.



Figure 1. Location of Inner Mongolia Autonomous Region in China

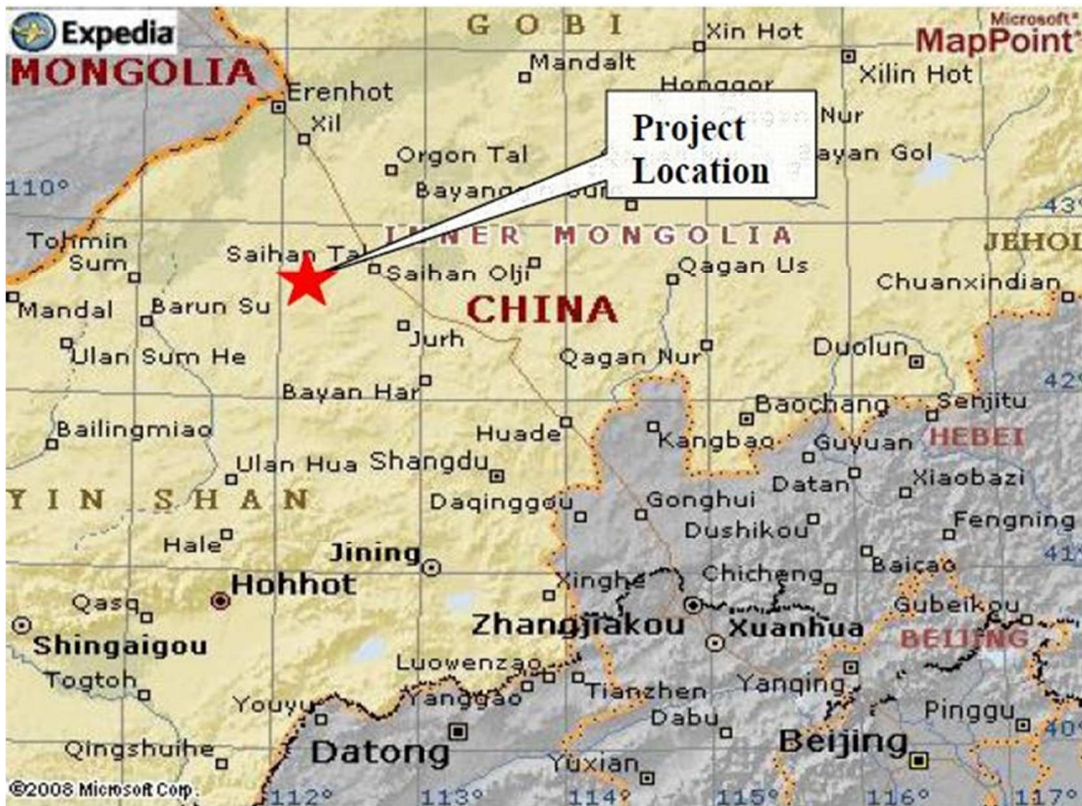

Figure 2. Location of the project

1.13 Conditions Prior to Project Initiation

The scenario existing prior to the start of the implementation of the project activity is NCPG providing the same electricity service as the Project;

The project scenario is the implementation of the Project, which involves the installation of 24 wind turbines with capacities of 2000 kW each, which amount to a total installed capacity of 48MW, which will supply an average annual generation of 118,560 MWh to NCPG and replace the same amount of electricity generated by fossil fuel fired power plants connected to NCPG;

The baseline scenario is the same as the scenario existing prior to the start of implementation of the project activity

1.14 Compliance with Laws, Statutes and Other Regulatory Frameworks

The project is wind power generation project and meets the relevant provisions of the Law of the People's Republic of China.

The main sectoral policy relevant to the project is the 'Renewable Energy Law of the People's Republic of China', which came into effect on 01/01/2006, and which aims to promote renewable energy in the Host Country. This Law demonstrates the Chinese Government's commitment to the development of renewable energy as part of the overall energy development strategy, and encourages grid-connected power generation from renewable sources. Nevertheless, there are no direct incentives, such as financial grants, higher tariffs, or subsidized loans available for these types of project.

In addition, although energy efficiency and renewable energy were included in the agenda for the Host Country's 13th Five-Year Plan (2016-2020), there is no legislative requirement to meet the projections under this Plan.

1.15 Participation under Other GHG Programs

1.15.1 Projects Registered (or seeking registration) under Other GHG Program(s)

The project has been registered as a Clean Development Mechanism (CDM) project in UNFCCC on 09/06/2011 (UNFCCC Ref. 4795), with the 7 years crediting period started from 09/06/2011. Total GHG emission reductions of 70,876 tCO₂ generated from 09/06/2011 to 20/05/2012 (both days included) by the project has been issued as CERs under CDM program. Please refer to the following link for details:

<https://cdm.unfccc.int/Projects/DB/BVQI1305287203.94/view?cp=1>

Except for CDM, the project did not register under any other GHG program.

1.15.2 Projects Rejected by Other GHG Programs

NA

1.16 Other Forms of Credit

1.16.1 Emissions Trading Programs and Other Binding Limits

The project does not reduce GHG emissions from activities that are included in an emissions trading program or any other mechanism that includes GHG allowance trading.

1.16.2 Other Forms of Environmental Credit

The project hasn't sought or received another form of environmental credits.

1.17 Additional Information Relevant to the Project

Leakage Management

NA.

Commercially Sensitive Information

No commercially sensitive information has been excluded from the public version of the project description.

Sustainable Development

The project makes contribution to the local sustainable development as follows:

GHG emission reduction

The project will help reduce the greenhouse gas GHG emissions versus the high-growth, coal-dominated business-as-usual scenario in the North China Power Grid by reducing the electricity generation from the fossil-fuel fired power plants, particularly the emission of SO_x, NO_x and dust.

Employment opportunities

The conducting of the project will offer job opportunities for local people, the estimated temporary job created in construction period and long-term job in the operational period are about 300 and 24, respectively.

Economic Improvement

The construction of the wind farm will promote local economy by contributing to local government with more tax revenues through selling power generation.

Further Information

NA.

2 SAFEGUARDS

2.1 No Net Harm

There are no negative environmental and/or socio-economic impacts due to the project. In fact, the project as a clean renewable energy project can reduce greenhouse gas emissions and the environmental pollution caused by fossil fuels consumption. Meanwhile, the implementation of the project will improve local socio-economic development through creating career opportunities and paying taxes.

2.2 Local Stakeholder Consultation

In 21/03/2009, staff from the project owner carried out a survey of the local resident around the project location. The staff introduced the background of the project and then sent out 50 copies of questionnaire in a random way, 46 pieces of reply were received. Among the interviewees, 23 of them are governmental officials, 8 teachers, 3 workers, 1 student, 1 farmer and 10 others.

An invitation notice for stakeholder comments was later issued by the project developer, 23 representatives of local stakeholders, including governmental officials of local county and local resident, etc attended the meeting in 21/03/2009 to discuss the questionnaires collected and further introduce the project. No negative opinion on construction of the project is heard and environmental considerations expressed by stakeholders are discussed on the meeting.

The questions regarding the project were mainly as follows:

1. How is the current environment quality?
2. Do you currently experience electromagnetic interference when watching TV at home?
3. Are there any negative impacts of the project on the everyday life of local residents?
4. Is the project going to help improve the local economy?
5. Does the project impact on local sound/noise environment?
6. Which is the environmental topic that concerns you the most during the construction and operation of the project?
7. Do you support the project?

The summary of survey is listed as the following:

- 35 (76%) of them think the current environment quality is good, 10 (22%) think it is normal and 1 (2%) of them are unsure;
- 26 (57%) of them doesn't experience electromagnetic interference, 14 (30%) experiences and 6(13%) of them are not sure;

- 32 (70%) of them think there will not be any negative impacts on their everyday life, 7(15%) of them thinks there will be and 7(15%) of them are not sure;
- 42 (91%) of them think the project will help to improve the local economy, none of them don't think so and 4(9%) of them are not sure;
- 22 (48%) of them think the project doesn't impact on local sound/noise environment, 4 (9%) of them think it will, 20 (43%) of them are unsure;
- Regarding the construction and operation of the propose project, 20 (43%) of them are most concerned with the noise level and 23 (50%) of them are most concerned with wastewater;
- 45 (98%) of them support the implementation of the project and 1 (2%) of them don't care.

Conclusion: The local community possesses basically positive comments on the effects of the project. The interviewees considered that local social, economic and environmental development would be beneficial from the project. The response was overall supportive to the project implementation.

2.3 Environmental Impact

The environmental impact assessment for this project was carried out by Inner Mongolia Power Exploration & Design Institute on 22/05/2008 and approved by Inner Mongolia Environmental Protection Bureau on 10/07/2008. A summary of the report is illustrated as below:

Ambient air

The impact on ambient air quality of the project is mainly from dust during construction stage, by sprinkling water frequently and timely clearing can reduce the dust pollution. When the project is in operational period, there will be no air pollutions. In conclusion, the project will not pose any threat on the quality of ambient air.

Impact from noise

There is some noise caused by operation of equipment. However, the location arrangement of wind turbines is seriously considered to avoid adverse influence to the residents. The noise level is in accordance with the National Standard (Grade II of the Noise Standard for City Environment GB12348-90: below daytime 55 dB (A), night-time 45 dB (A)). Hence, the noise will not impact the work and daily life of local residents.

Electromagnetic impact

The operation of the wind farm will generate electromagnetic pollution, whereas the pollution is slight. In addition, the project is very far from local resident and village. Therefore, the electronic magnetic pollution to the surrounding environment is insignificant.

Impact from Solid waste

There is mainly some waste of stone, bricks or domestic waste in the construction stage and basically no solid waste in the operational period. Solid waste will be collected and handled properly. Hence, it will not result any environmental impact.

Impact from Wastewater

There is mainly domestic wastewater with fairly small quantities in construction stage, and primary treatment methods will be first applied, small-scale septic tanks should be built on the site, through which the wastewater can finally meet the standard of discharge after treatment. Therefore, the impact of wastewater is limited and mitigated.

Impact on ecological environment

The project will both permanently and temporarily occupy some land (mostly farmland), the temporarily occupied land will be ecologically restored for original use. Such restoration measures will include land re-surfacing, re-vegetation, and etc. As for the permanently occupied land, ecological compensation measures will be applied to the adjacent area to offset the impact on ecosystem.

No migrating birds have been found in the project field till now. Therefore, the project is not located on the passage of migrating birds, and the project construction will not influence the migration of birds.

The Project use clean renewable energy to generate electricity whose environmental impact comply with relevant environmental laws and regulations in the host country. The environmental impacts of the project are not considered significant.

2.4 Public Comments

The project developer published the project documents on the UNFCCC CDM website (<http://cdm.unfccc.int>) on 13/08/2009 and invited comments within 12/09/2009 by Parties, stakeholders and non-governmental organizations. No comments were received during this period.

2.5 AFOLU-Specific Safeguards

NA.

3 APPLICATION OF METHODOLOGY

3.1 Title and Reference of Methodology

The approved methodology applied in the project activity is ACM0002 (version 20.0) – “Grid-connected electricity generation from renewable sources”.

Reference: <https://cdm.unfccc.int/methodologies/DB/XP2LKUSA61DKUQCOPiWPGWDN8ED5PG>

This methodology also refers to the latest approved version of the following tools: “Tool for the demonstration and assessment of additionality (version 07.0.0)”

Reference: <http://cdm.unfccc.int/methodologies/PAmethodologies/tools/am-tool-01-v7.0.0.pdf>

“Tool to calculate the emission factor for an electricity system (version 07.0)” is applied in the project.

Reference: <http://cdm.unfccc.int/methodologies/PAmethodologies/tools/am-tool-07-v7.0.pdf>

Assessment of the validity of the original/current baseline and update of the baseline at the renewal of the crediting period (Version 03.0.1).

Reference: <http://cdm.unfccc.int/methodologies/PAmethodologies/tools/am-tool-11-v3.0.1.pdf>

Baseline, project and/or leakage emissions from electricity consumption and monitoring of electricity generation (Version 03.0).

Reference: <http://cdm.unfccc.int/methodologies/PAmethodologies/tools/am-tool-05-v3.0.pdf>.

3.2 Applicability of Methodology

The approved methodology ACM0002 (version 20.0) is applicable to the project activity and the project meets the applicability of the applied methodology, because:

The approved methodology ACM0002 (version 20.0) is applicable to the project activity and the project meets the applicability of the applied methodology as follows:

Clauses	Requirements of the ACM0002	Scenario of the project	Conclusion
1	This methodology is applicable to grid-connected renewable energy power generation project activities that: <ul style="list-style-type: none"> a) Install a Greenfield power plant; b) Involve a capacity addition to (an) existing plant(s); c) Involve a retrofit of (an) existing operating plants/units; d) Involve a rehabilitation of (an) existing plant(s)/unit(s); or e) Involve a replacement of (an) existing plant(s)/unit(s). 	The project is a greenfield NCPG-connected renewable power generation project.	Applicable
2	The methodology is applicable under the following conditions: <ul style="list-style-type: none"> (a) The project activity may include renewable energy power plant/unit of one of the following types: hydro power plant/unit with or without reservoir, wind power plant/unit, geothermal power plant/unit, solar power plant/unit, wave power plant/unit or tidal power plant/unit; (b) In the case of capacity additions, retrofits, rehabilitations or replacements (except for wind, solar, wave or tidal power capacity addition projects the existing plant/unit started commercial operation prior to the start of a minimum historical reference period of five years, used for the calculation of baseline emissions and defined in the baseline emission section, and no capacity expansion, retrofit, or rehabilitation of the plant/unit has been undertaken between the start of this minimum historical reference period and the implementation of the project activity. 	The project is a newly built wind power project and the project activity involves the installation of the wind power plant.	Applicable
3	In case of hydro power plants, one of the following conditions must apply:	Not applicable, the project is not a hydro power plant, so this applicability condition	NA

Clauses	Requirements of the ACM0002	Scenario of the project	Conclusion
	<p>(a) The project activity is implemented in existing single or multiple reservoirs, with no change in the volume of any of the reservoirs; or</p> <p>(b) The project activity is implemented in existing single or multiple reservoirs, where the volume of the reservoir(s) is increased and the power density calculated using equation (7), is greater than 4 W/m²; or</p> <p>(c) The project activity results in new single or multiple reservoirs and the power density, calculated using equation (7), is greater than 4 W/m²; or</p> <p>(d) The project activity is an integrated hydro power project involving multiple reservoirs, where the power density for any of the reservoirs, calculated using equation (7), is lower than or equal to 4 W/m², all of the following conditions shall apply:</p> <p>(i) The power density calculated using the total installed capacity of the integrated project, as per equation (8), is greater than 4 W/m²;</p> <p>(ii) Water flow between reservoirs is not used by any other hydropower unit which is not a part of the project activity;</p> <p>(iii) Installed capacity of the power plant(s) with power density lower than or equal to 4 W/m² shall be:</p> <p>a. Lower than or equal to 15 MW; and</p>	<p>does not need to be considered.</p>	

Clauses	Requirements of the ACM0002	Scenario of the project	Conclusion
	b. Less than 10 per cent of the total installed capacity of integrated hydro power project.		
4	In the case of integrated hydro power projects, project proponent shall: Demonstrate that water flow from upstream power plants/units spill directly to the downstream reservoir and that collectively constitute to the generation capacity of the integrated hydro power project; or Provide an analysis of the water balance covering the water fed to power units, with all possible combinations of reservoirs and without the construction of reservoirs. The purpose of water balance is to demonstrate the requirement of specific combination of reservoirs constructed under CDM project activity for the optimization of power output. This demonstration has to be carried out in the specific scenario of water availability in different seasons to optimize the water flow at the inlet of power units. Therefore, this water balance will take into account seasonal flows from river, tributaries (if any), and rainfall for minimum five years prior to implementation of CDM project activity.	Not applicable, the project is not a hydro power plant, so this applicability condition does not need to be considered.	NA
5	The methodology is not applicable to: a) Project activities that involve switching from fossil fuels to renewable energy sources at the site of the project activity, since in this case the baseline may be the continued use of fossil fuels at the site; b) Biomass fired power plants/units.	The project does not involve switching from fossil-fuels to renewable energy sources at the site of the project activity and the project is not a biomass-fired power project.	Applicable
6	In the case of retrofits, rehabilitations, replacements, or capacity additions, this methodology is only applicable if the most plausible baseline scenario, as a result of the identification of	Not applicable, the project is a newly built wind power project.	NA

Clauses	Requirements of the ACM0002	Scenario of the project	Conclusion
	baseline scenario, is “the continuation of the current situation, that is to use the power generation equipment that was already in use prior to the implementation of the project activity and undertaking business as usual maintenance”.		

In addition, the project meets the applicability conditions of the applied tools applied in the PD as follows:

Tool	Criteria	Applicability	Conclusion
Tool to calculate the emission factor for an electricity system	This tool may be applied to estimate the OM, BM and/or CM when calculating baseline emissions for a project activity that substitutes grid electricity that is where a project activity supplies electricity to a grid or a project activity that results in savings of electricity that would have been provided by the grid (e.g. demand-side energy efficiency projects).	The project is the installation of a wind power plant supplying electricity to the grid.	Applicable
Tool to calculate the emission factor for an electricity system	In case of CDM projects the tool is not applicable if the project electricity system is located partially or totally in an Annex I country.	The project electricity system is located in a non-Annex I country.	Applicable
Baseline, project and/or leakage emissions from electricity consumption and monitoring of electricity generation.	If emissions are calculated for electricity consumption, the tool is only applicable if one out of the following three scenarios applies to the sources of electricity consumption: (a) Scenario A: Electricity consumption from the grid. (b) Scenario B: Electricity consumption from (an) off-grid fossil fuel fired captive power plant(s). or (c) Scenario C: Electricity consumption from the grid and (a) fossil fuel fired captive power plant(s).	The electricity consumption of the project is purchased from the grid.	Applicable

Tool	Criteria	Applicability	Conclusion
Baseline, project and/or leakage emissions from electricity consumption and monitoring of electricity generation.	This tool can be referred to in methodologies to provide procedures to monitor amount of electricity generated in the project scenario, only if one out of the following three project scenarios applies to the recipient of the electricity generated: (a) Scenario I: Electricity is supplied to the grid; (b) Scenario II: Electricity is supplied to consumers/electricity consuming facilities; or (c) Scenario III: Electricity is supplied to the grid and consumers/electricity consuming facilities.	The electricity generated by the project is supplied to the grid.	Applicable
Baseline, project and/or leakage emissions from electricity consumption and monitoring of electricity generation.	This tool is not applicable in cases where captive renewable power generation technologies are installed to provide electricity in the project activity, in the baseline scenario or to sources of leakage. The tool only accounts for CO ₂ emissions.	There are no captive renewable power generation technologies installed to provide electricity in the project activity, in the baseline scenario or to sources of leakage.	Applicable
Tool for assessment of the validity of the original/current baseline and update of the baseline at the renewal of the crediting period”	This tool provides a stepwise procedure to assess the continued validity of the baseline and to update the baseline at the renewal of a crediting period, as required by paragraph 49 (a) of the modalities and procedures of the clean development mechanism. The tool consists of two steps: The first step provides an approach to evaluate whether the current baseline is still valid for the next crediting period. The second step provides an approach to update the baseline in case that the current baseline is not	The validity of the baseline of the project is assessed by the following two steps: Evaluate whether the current baseline is still valid for the next crediting period; Update the baseline in case that the current baseline is not valid anymore for	Applicable

Tool	Criteria	Applicability	Conclusion
	valid anymore for the next crediting period.	the next crediting period.	

3.3 Project Boundary

According to ACM0002 (version 20.0), the spatial extent of the project boundary includes the project power plant and all the power plants connected physically and geographically to electricity system that the project power plant is connected to. According to the “Tool to calculate the emission factor for an electricity system (version 07.0)”, the electricity system is defined by the spatial extent of the power plants that are physically connected through transmission and distribution lines to the project activity (e.g. the renewable power plant location or the consumers where electricity is being saved) and that are covered by either single or layered dispatch area.

Electricity generated by the Project was delivered to North China Power Grid (NCPG). According to 2017 Baseline Emission Factors for Regional Power Grids in China issued by China’s DNA¹, The NCPG is composed of Beijing, Tianjin, Hebei, Shandong, Shanxi and Inner Mongolia power grids, therefore, NCPG was defined as the electricity system the project is connected to, and the spatial extent of the project boundary includes the project power plant and all the power plants connected physically and geographically to NCPG.

¹ http://www.mee.gov.cn/ywgz/ydqhbh/wsqtzk/index_1.shtml

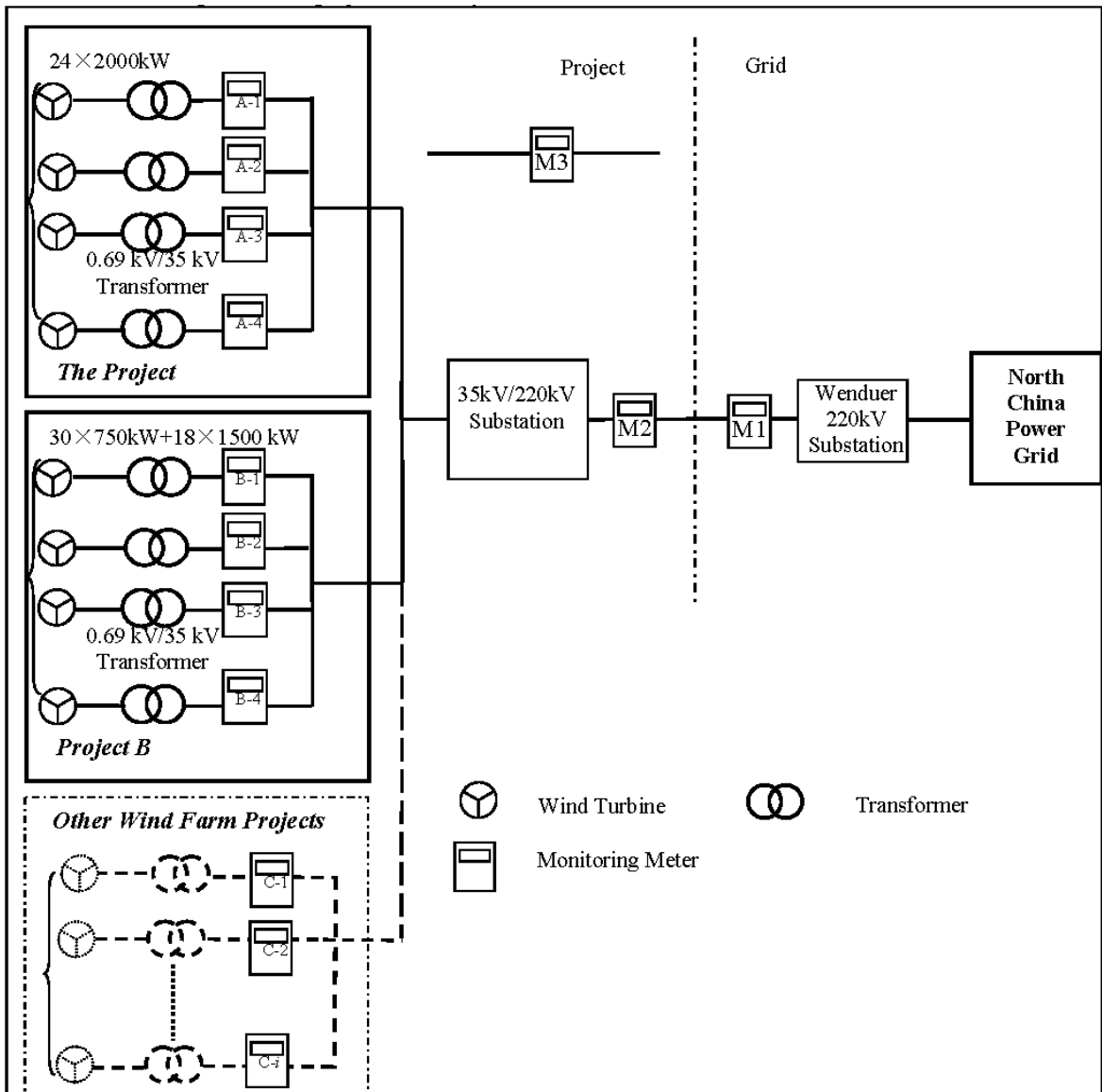

Figure 3. The boundary of the project

According to the approved methodology ACM0002 (version 20.0), the emission sources and GHGs in the project boundary are as follows:

Source	Gas	Included?	Justification/Explanation
Baseline	CO ₂ emissions from electricity generation in fossil fuel-fired	Yes	Main emission source
		CH ₄	No

Source	Gas	Included?	Justification/Explanation
power plants that is displaced due to the project activity.	N ₂ O	No	Minor emission source
Project The wind power plant	CO ₂	No	According to ACM0002, the project emission of renewable energy project activity should not be considered.
	CH ₄	No	
	N ₂ O	No	

3.4 Baseline Scenario

In accordance with “Assessment of the validity of the original/current baseline and update of the baseline at the renewal of the crediting period” (version 03.0.1), the validity of the current baseline is assessed using the following sub-steps:

Step 1: Assess the validity of the current baseline for the next crediting period

Step 1.1: Assess compliance of the current baseline with relevant mandatory national and/or sectoral policies

There are no new national and/or sectoral policies that could affect the baseline scenario during the renewal of the crediting period. For total electricity generation produced by fossil fuel power plants, the average share of the five most recent years is more than 50% of total electricity generation in NCPG. Hence in the absence of the project activity, electricity would still have been generated in the existing grid-connected power plants or by the addition of new generation sources from NCPG. The current baseline still complies with all relevant mandatory national and sectoral policies which have come into effect after the submission of the project activity for validation and are applicable at the time of requesting renewal of the crediting period. Go to step 1.2.

Step 1.2: Assess the impact of circumstances

The baseline scenario identified at the validation of the project activity was the continuation of the current practice without any investment. The investment environment or market characteristics especially the feed-in tariff, the policy in terms of market access permit, these circumstances continue during the second crediting period and therefore, do not have an impact on the current baseline emissions. Hence the current baseline does not need to be updated. Go to step 1.3.

Step 1.3: Assess whether the continuation of use of current baseline equipment(s) or an investment is the most likely scenario for the crediting period for which renewal is requested.

The project is a greenfield project with a lifetime of 20 operation years, with no baseline equipment(s) or an investment for the crediting period for which renewal is requested, this step is not applicable. Go to step 1.4.

Step 1.4: Assessment of the validity of the data and parameters

Data and parameters that need to be updated are as follows:

$EF_{grid,CM,y}$: the baseline emission factor that determined once for the first crediting period at the time of validation, hence it shall be updated using the latest version of “Tool to calculate the emission factor for an electricity system”.

Application of Steps 1.1, 1.2, 1.3 and 1.4 confirmed that the current baseline is valid for the second crediting period but data and parameters need to be updated. Therefore step 2 is used.

Step 2: Update the current baseline and the data and parameters

Step 2.1: Update the current baseline

The baseline emissions for the second crediting period has been updated, without reassessing the baseline scenario, based on the latest approved version of the methodology ACM0002 (Version 20.0). This update was applied in the context of the sectoral policies and circumstances that is applicable at the time of requesting for renewal of the crediting period. More details for the updated baseline emissions for the second crediting period can be seen in section 4.

Step 2.2: Update the data and parameters

The updated baseline emission factor for the project ($EF_{grid,CM,y}$) is 0.8405 tCO_{2e}/MWh.

3.5 Additionality

The project has demonstrated its additionality in the first crediting period and no changes affect the additionality of the project since its registration.

3.6 Methodology Deviations

There is a deviation on calculation of Build Margin when adopting the methodological tool – “Tool to calculate the emission factor for an electricity system” by the Chinese DNA in the “2017 Baseline Emission Factors for Regional Power Grids in China”. The deviation has been approved by the EB Board in a response letter entitled “Request for clarification on use of approved methodology AM0005 for several projects in China”, thus the same deviation method has been adopted in the first and second crediting periods of the project by the Chinese DNA.

4 QUANTIFICATION OF GHG EMISSION REDUCTIONS AND REMOVALS

4.1 Baseline Emissions

The GHG emission reduction calculation of the project was based on the applied methodology ACM0002 (version 20.0).

Baseline Emission calculation:

$$BE_y = EG_{PJ,y} \times EF_{grid,CM,y} \quad (1)$$

Where:

BE_y Baseline emissions in year y (tCO₂e)

$EG_{PJ,y}$ Quantity of net electricity generation that is produced and fed into the grid as a result of the implementation of the VCS project activity in year y

$EF_{grid,CM,y}$ Combined margin CO₂ emission factor for grid connected power generation in year y calculated using the latest version of the “Tool to calculate the emission factor for an electricity system” (tCO₂e/MWh)

The project activity is a Greenfield wind power plant, then:

$$EG_{PJ,y} = EG_{facility,y} \quad (2)$$

Where:

$EG_{PJ,y}$ Quantity of net electricity generation that is produced and fed into the grid as a result of the implementation of the VCS project activity in year y

$EG_{facility,y}$ Quantity of net electricity generation supplied by the project plant/unit to the grid in year y (MWh)

And the baseline emission factor $EF_{grid,CM,y}$ is calculated as per the latest version of “Tool to calculate the emission factor for an electricity system” (version 07.0). The $EF_{grid,CM,y}$ is calculated ex ante and fixed for the second crediting period. Detailed as follows:

Step 1. Identify the relevant electricity system

For determining the electricity emission factors, identify the relevant project electricity system. Similarly, identify any connected electricity system. If a connected electricity system is located partially or totally in Annex-I countries, then the emission factor of that connected electricity system should be considered zero. If the DNA of the host country has published a delineation of the project electricity system and connected electricity systems, these delineations should be used.

The Chinese DNA has published a delineation of the project electricity system and connected electricity systems, this delineation is used. Following the DNA delineation, the project electricity system is the North China Power Grid, which consists of Beijing, Tianjin, Hebei, Shandong, Shanxi and Inner Mongolia Power Grids. Therefore, North China Power Grid is chosen as the relevant electric power system.

Step 2. Choose whether to include off-grid power plants in the project electricity system (optional)

Project participants may choose between the following two options to calculate the operating margin and build margin emission factor:

Option I: Only grid power plants are included in the calculation.

Option II: Both grid power plants and off-grid power plants are included in the calculation.

Based on China's real situation, only grid power plants are included in the calculation.

Step 3. Select a method to determine the operating margin (OM)

The calculation of the operating margin emission factor ($EF_{grid,OM,y}$) is based on the following methods:

- (a) Simple OM, or
- (b) Simple adjusted OM, or
- (c) Dispatch Data Analysis OM, or
- (d) Average OM.

Detailed information to carry out a dispatch data analysis is not publicly available; therefore, method (b) and method (c) is not suitable for the project.

According to tool, the Simple OM method is applicable to the project if the low-cost resources constitute less than 50% of total grid generation on average in the five most recent years or based on long-term normal for hydroelectric production.

According to the data from China Electric Power Yearbook 2013-2017, from year 2012 to year 2016, for the NCPG the project activity connected to, the low-cost/must-run electric power resources generation accounts for the total grid total are 4.96%, 5.92%, 6.39%, 7.21% and 8.94%, respectively, all lower than 50%, which satisfied the applicability of the method (a), therefore, the simple OM method is chosen for the calculation of the OM emission factor $EF_{grid,OM,y}$.

The Simple OM can be calculated using either of the two following data vintages for years(s) y:

(a) (Ex-ante option): If the ex-ante option is chosen, the emission factor is determined once at the validation stage, thus no monitoring and recalculation of the emissions factor during the crediting period is required. For grid power plants, use a 3-year generation-weighted average, based on the most recent data available at the time of submission of the CDM-PDD to the DOE for validation.

(b) (Ex-post option): If the ex post option is chosen, the emission factor is determined for the year in which the project activity displaces grid electricity, requiring the emission factor to be updated annually during monitoring.

Here ex-ante vintage is chosen, and the $EF_{grid,OM,y}$ is fixed during the second crediting period.

Step 4. Calculate the operating margin emission factor according to the selected method

The Simple OM emission factor is calculated as the generation-weighted average CO₂ emissions per unit net electricity generation (tCO₂/MWh) of all generating power plants serving the system, not including low-cost/must-run power plants/units. The simple OM may be calculated:

- (a) **Option A:** Based on the net electricity generation and a CO₂ emission factor of each power unit, or
- (b) **Option B:** Based on the total net electricity generation of all power plants serving the system and the fuel types and total fuel consumption of the project electricity system.

For the project activity, the required data for the exercise of Option A is not available and those of Option B can be obtained from official sources, and off-grid power plants are not included in the calculation, therefore, Option B is chosen to calculate the operating margin emission factor:

For Option B, the Simple OM emission factor is calculated based on the net electricity supplied to the grid by all power plants serving the system, not including low-cost/must-run power plants/units, and based on the fuel type(s) and total fuel consumption of the project electricity system, as follows:

$$EF_{grid,OMsimple,y} = \frac{\sum_{i,m} FC_{i,y} \times NCV_{i,y} \times EF_{CO_2,i,y}}{\sum_m EG_y} \quad (3)$$

Where:

$EF_{grid,OMsimple,y}$	Simple operating margin CO ₂ emission factor in year y (tCO ₂ /MWh)
$FC_{i,y}$	Amount of fuel type i consumed in the project electricity system in year y (mass or volume unit)
$NCV_{i,y}$	Net calorific value (energy content) of fuel type i in year y (GJ/mass or volume unit)
$EF_{CO_2,i,y}$	CO ₂ emission factor of fuel type i in year y (tCO ₂ /GJ)
EG_y	Net electricity generated and delivered to the grid by all power sources serving the system, not including low-cost/must-run power plants/units, in year y (MWh)
i	All fuel types combusted in power sources in the project electricity system in year y
y	The relevant year as per the data vintage chosen in Step 3

Regarding parameter selection, local values of $NCV_{i,y}$ and $EF_{CO_2,i,y}$ should be used where available. If no such values are available, IPCC world-wide default values are preferable. In this PD, the Net Calorific Value ($NCV_{i,y}$) of each type of fossil fuel used in the calculation comes from China Energy Statistic Yearbook 2014-2016. Emission factors ($EF_{CO_2,i,y}$) of each type of fossil fuel come from IPCC 2006 default values.

The Simple OM Emission Factor ($EF_{grid,OMsimple,y}$) of the project is calculated on the basis of the fuel consumption data for electricity generation of the NCPG, not including those of low-operating cost and must-run power plants, such as wind power, hydropower and nuclear etc. These data are obtained from the China Electric Power Yearbook (2014~2016, published annually) and China Energy Statistical Yearbook (2014~2016). Based on these data, the Simple OM Emission Factor ($EF_{grid,OMsimple,y}$) of the NCPG is calculated as 0.9680 tCO₂e/MWh.

Step 5. Calculate the combined margin emission factor

In terms of vintages of data, project participants can choose between one of the following two options:

Option 1 For the first crediting period, calculate the build margin emission factor, ex ante based on the most recent information available on units already built for sample group m at the time of

CDM-PDD submission to the DOE for validation. For the second crediting period, the build margin emission factor should be updated based on the most recent information available on units already built at the time of submission of the request for renewal of the second crediting period should be used. For the third crediting period, the build margin emission factor calculated for the second crediting period should be used. This option does not require monitoring the emission factor during the crediting period.

Option 2 For the first crediting period, the build margin emission factor shall be updated annually, ex post, including those units built up to the year of registration of the project activity or, if information up to year of registration is not yet available, including those units built up to the latest year for which information is available. For the second crediting period, the build margin emissions factor shall be calculated ex ante, as described in option 1 above. For the third crediting period, the build margin emission factor calculated for the second crediting period should be used.

The PD chooses **Option 1**, which requires the project participant to calculate the Build Margin Emission Factor $EF_{grid, BM, y}$, ex-ante based on the most recent information available on units already built for sample group m at the time of PD submission.

The sample group of power units m used to calculate the build margin should be determined as per the following procedure, consistent with the data vintage selected above:

(a) Identify the set of five power units, excluding power units registered as CDM project activities, that started to supply electricity to the grid most recently ($SET_{5-units}$) and determine their annual electricity generation ($AEG_{SET-5-units}$, in MWh);

(b) Determine the annual electricity generation of the project electricity system, excluding power units registered as CDM project activities (AEG_{total} , in MWh). Identify the set of power units, excluding power units registered as CDM project activities, that started to supply electricity to the grid most recently and that comprise 20 percent of AEG_{total} (if 20 per cent falls on part of the generation of a unit, the generation of that unit is fully included in the calculation) ($SET_{\geq 20 \text{ percent}}$) and determine their annual electricity generation ($AEG_{SET-\geq 20 \text{ percent}}$, in MWh);

(c) From $SET_{5-units}$ and $SET_{\geq 20 \text{ percent}}$ select the set of power units that comprises the larger annual electricity generation (SET_{sample});

Otherwise:

(d) Exclude from SET_{sample} the power units which started to supply electricity to the grid more than 10 years ago. Include in that set the power units registered as CDM project activity, starting

with power units that started to supply electricity to the grid most recently, until the electricity generation of the new set comprises 20 percent of the annual electricity generation of the project electricity system (if 20 percent falls on part of the generation of a unit, the generation of that unit is fully included in the calculation) to the extent is possible. Determine for the resulting set ($SET_{\text{sample-CDM}}$) the annual electricity generation ($AEG_{\text{SET-sample-CDM}}$, in MWh);

If the annual electricity generation of that set is comprises at least 20 percent of the annual electricity generation of the project electricity system (i.e. $AEG_{\text{SET-sample-CDM}} \geq 0.2 \times AEG_{\text{total}}$), then use the sample group $SET_{\text{sample-CDM}}$ to calculate the build margin. Ignore steps (e) and (f).

(e) Include in the sample group $SET_{\text{sample-CDM}}$ the power units that started to supply electricity to the grid more than 10 years ago until the electricity generation of the new set comprises 20 percent of the annual electricity generation of the project electricity system (if 20 percent falls on part of the generation of a unit, the generation of that unit is fully included in the calculation);

(f) The sample group of power units m used to calculate the build margin is the resulting set ($SET_{\text{sample-CDM-}>10\text{yrs}}$).

However, in China, it is very difficult to obtain the data of the five existing power plants built most recently or the power plants capacity additions in the electricity system that comprise 20 percent of the system generation (in MWh) and that were built most recently, since no data of plant specific generation and fossil fuel consumption is currently available in China. As none of the above options can be selected, the following deviations are adopted to calculate the BM:

First, to calculate the newly added installed capacity and the contribution component of other various power generation technologies, then calculate of the weight of newly added installed capacity of each power generation technology, and finally, to calculate BM emission factor using the commercially optimal efficiency level of each power generation technology.

According to the “Tool to calculate the emission factor for an electricity system”, the build margin emissions factor ($EF_{\text{grid,BM},y}$) is calculated as the generation-weighted average emission factor (tCO₂e/MWh) of all power units m during the most recent year y for which power generation data is available. The calculation equation is as follows:

$$EF_{\text{grid,BM},y} = \frac{\sum_m EG_{m,y} \times EF_{EL,m,y}}{\sum_m EG_{m,y}} \quad (4)$$

Where:

$EF_{\text{grid,BM},y}$ Build margin CO₂ emission factor in year y (tCO₂/MWh)

$EG_{m,y}$	Net quantity of electricity generated and delivered to the grid by power unit m in year y (MWh)
$EF_{EL,m,y}$	CO ₂ emission factor of power unit m in year y (tCO ₂ /MWh)
m	Power units included in the build margin
y	Most recent historical year for which electricity generation data is available

Since the generating capacity of coal-fired, oil-fired and gas-fired technologies can't be separated from the existing statistical data, the following measures are taken for the calculation:

First, based on the available data of the latest year, determine the ratio of CO₂ emissions from coal, oil, and gas consumption for power generation to the total CO₂ emission; Second, to calculate the emission factor of the thermal power based on the weight of CO₂ emission from coal, oil, and gas, and the emissions factors using commercial technologies with optimal efficiency. And finally, to multiply the thermal emission factor with the portion of the thermal power comprising 20 percent of the newly added capacity.

Sub-step 5.1. Calculation of weights of CO₂ emissions of solid, liquid and gaseous fossil fuels in total emissions for power generation.

$$\lambda_{Coal,y} = \frac{\sum_{i \in COAL,j} F_{i,j,y} \times NCV_{i,y} \times EF_{CO_2,i,j,y}}{\sum_{i,j} F_{i,j,y} \times NCV_{i,y} \times EF_{CO_2,i,j,y}} \quad (5)$$

$$\lambda_{Oil,y} = \frac{\sum_{i \in OIL,j} F_{i,j,y} \times NCV_{i,y} \times EF_{CO_2,i,j,y}}{\sum_{i,j} F_{i,j,y} \times NCV_{i,y} \times EF_{CO_2,i,j,y}} \quad (6)$$

$$\lambda_{Gas,y} = \frac{\sum_{i \in GAS,j} F_{i,j,y} \times NCV_{i,y} \times EF_{CO_2,i,j,y}}{\sum_{i,j} F_{i,j,y} \times NCV_{i,y} \times EF_{CO_2,i,j,y}} \quad (7)$$

Where:

$FC_{i,j,y}$	Amount of fossil fuel type i consumed in province j in year y (mass or volume unit)
$NCV_{i,y}$	Net calorific value (energy content) of fossil fuel type i in year y (GJ/t or GJ/m ³)
$EF_{CO_2,i,j,y}$	CO ₂ emission factor of fossil fuel type i in year y (tCO ₂ e/GJ)

Coal, Oil and Gas refer to the group of solid, liquid, and gaseous fossil fuels, respectively.

Sub-step 5.2: Calculation of Emission Factor of Relevant Thermal Power

$$EF_{Thermal,y} = \lambda_{Coal,y} \times EF_{Coal,Adv,y} + \lambda_{Oil,y} \times EF_{Oil,Adv,y} + \lambda_{Gas,y} \times EF_{Gas,Adv,y} \quad (8)$$

Where:

$EF_{Coal,Adv}$, $EF_{Oil,Adv}$ and $EF_{Gas,Adv}$ refer to the emission factors representing best technologies commercially available for coal, oil and gas fired power plants, respectively.

Sub-step 5.3: Calculate of BM of the grid

Using the share of different type of capacity in total capacity addition as weight, the weighted average of emission factors of different type capacity is calculated as the Build Margin emission factor $EF_{grid,BM,y}$ of North China Power Grid.

$$EF_{grid,BM,y} = \frac{CAP_{Thermal,y}}{CAP_{Total,y}} \times EF_{Thermal,y} \quad (9)$$

Where:

$CAP_{Total,y}$ The total newly added electricity generation capacity (MW);

$CAP_{thermal,y}$ The newly added electricity generation capacity of thermal power (MW)

Key parameters used to calculate BM emission factor include the low calorific value of each fossil fuel, the oxidation rate, the potential emission factors, and the efficiency of various power generation technologies. The data of low calorific value of each fossil fuel and their oxidation rate comes from China Energy Statistical Yearbook 2014-2016. The potential emission factors are sourced from “2006 IPCC Guidelines for National Greenhouse Gas Inventories” Table 1.3 and Table 1.4 of Page 1.21-1.24 in Chapter one, Volume 2 Energy.

Based on these data, the $EF_{grid,BM,y}$ of the North China Grid is calculated as 0.4578 tCO₂e/MWh.

Step 6. Calculate the combined margin emission factor

The calculation of the combined margin (CM) emission factor ($EF_{grid,CM,y}$) is based on one of the following methods:

- (a) Weighted average CM; or
- (b) Simplified CM.

The weighted average CM method (**option A**) should be used as the preferred option. And the PD choose option A.

The combined margin emissions factor ($EF_{grid,CM,y}$) is calculated as follows:

$$EF_{grid,CM,y} = \omega_{OM} \times EF_{grid,OM,y} + \omega_{BM} \times EF_{grid,BM,y} \quad (10)$$

Where:

$EF_{grid,BM,y}$	Build margin CO ₂ emission for the project electricity system factor in year y (tCO ₂ e /MWh)
$EF_{grid,OM,y}$	Operating margin CO ₂ emission factor for the project electricity system in year y (tCO ₂ e /MWh)
ω_{OM}	Weighting of operating margin emissions factor (%)
ω_{BM}	Weighting of build margin emissions factor (%)

The Combined Margin emissions factor $EF_{grid,CM,y}$ should be calculated as the weighted average of the Operating Margin emission factor $EF_{grid,OM,y}$ and the Build Margin emission factor $EF_{grid,BM,y}$, where $\omega_{OM} = 0.75$ and $\omega_{BM} = 0.25$ for all other project excluded wind and solar project for the second and third crediting period. The $EF_{grid,OM,y}$ and $EF_{grid,BM,y}$ are calculated as described in Step 4 and 5.

Therefore,

$$EF_{grid,CM,y} = 0.9680 \text{ tCO}_2\text{e/MWh} * 0.75 + 0.4578 \text{ tCO}_2\text{e/MWh} * 0.25 = 0.8405 \text{ (tCO}_2\text{e/MWh)}$$

$$BE_y = 118,560 \text{ MWh} * 0.8405 \text{ tCO}_2\text{e/MWh} = 99,643 \text{ tCO}_2\text{e}$$

4.2 Project Emissions

According to ACM0002 (version 20.0), the project is a GHG zero-emission electricity generating activity; therefore, no project emissions from the project activity were identified $PE_y = 0$.

4.3 Leakage

As per the applied methodology ACM0002, no leakage is considered.

4.4 Net GHG Emission Reductions and Removals

The annual emission reductions ER_y for the project activity are calculated as the baseline emissions minus the project emissions. The final GHG emission reductions are calculated as follows:

$$ER_y = BE_y - PE_y \quad (11)$$

Where:

ER_y Emission reductions in year y (tCO₂)

BE_y Baseline Emissions in year y (tCO₂)

PE_y Project emissions in year y (tCO₂)

The summary of ex ante estimates of emission reductions is shown as follows:

Year	Estimated baseline emissions or removals (tCO ₂ e)	Estimated project emissions or removals (tCO ₂ e)	Estimated leakage emissions (tCO ₂ e)	Estimated net GHG emission reductions or removals (tCO ₂ e)
27/10/2019-31/12/2019	18,018	0	0	18,018
01/01/2020-31/12/2020	99,643	0	0	99,643
01/01/2021-31/12/2021	99,643	0	0	99,643
01/01/2022-31/12/2022	99,643	0	0	99,643
01/01/2023-31/12/2023	99,643	0	0	99,643
01/01/2024-31/12/2024	99,643	0	0	99,643
01/01/2025-31/12/2025	99,643	0	0	99,643
01/01/2026-31/12/2026	99,643	0	0	99,643
01/01/2027-31/12/2027	99,643	0	0	99,643
01/01/2028-31/12/2028	99,643	0	0	99,643
01/01/2029-26/10/2029	81,625	0	0	81,625
Total	99,6430	0	0	99,6430

5 MONITORING

5.1 Data and Parameters Available at Validation

The baseline grid emission factor $EF_{grid,CM,y}$ is obtained directly from the official source *Notification on Determining Baseline Emission Factor of China's Grid* by China's DNA. Thus, the relevant basis parameters for calculation of $EF_{grid,CM,y}$ are not described in detail here. With consideration of the fact of the Project, data and parameters that are available at validation are summarized in below tables.

Data / Parameter	$EF_{grid,OM,y}$
Data unit	tCO ₂ e/MWh
Description	Operating margin emission factor for North China Power Grid
Source of data	"2017 Baseline Emission Factors for Regional Power Grids in China" published by China DNA
Value applied	0.9680
Justification of choice of data or description of measurement methods and procedures applied	Calculated as per the latest version of "Tool to calculate the emission factor for an electricity system" (version 06.0) by China DNA
Purpose of Data	Calculation of $EF_{grid,CM,y}$
Comments	Calculated ex ante and fixed for the second crediting period

Data / Parameter	$EF_{grid,BM,y}$
Data unit	tCO ₂ e/MWh
Description	Build margin emission factor for North China Power Grid
Source of data	"2017 Baseline Emission Factors for Regional Power Grids in China" published by China DNA
Value applied	0.4578
Justification of choice of data or description of measurement methods and procedures applied	Calculated as per the latest version of "Tool to calculate the emission factor for an electricity system" (version 06.0) by China DNA

Purpose of Data	Calculation of $EF_{grid,CM,y}$
Comments	Calculated ex ante and fixed for the second crediting period

Data / Parameter	ω_{OM}
Data unit	-
Description	Weighting of operating margin emissions factor
Source of data	“Tool to calculate the emission factor for an electricity system” (version 06.0)
Value applied	0.75
Justification of choice of data or description of measurement methods and procedures applied	-
Purpose of Data	Calculation of $EF_{grid,CM,y}$
Comments	Calculated ex ante and fixed for the second crediting period

Data / Parameter	ω_{BM}
Data unit	-
Description	Weighting of build margin emissions factor
Source of data	“Tool to calculate the emission factor for an electricity system” (version 06.0)
Value applied	0.25
Justification of choice of data or description of measurement methods and procedures applied	-
Purpose of Data	Calculation of $EF_{grid,CM,y}$
Comments	Calculated ex ante and fixed for the second crediting period

Data / Parameter	$EF_{grid,CM,y}$
Data unit	tCO ₂ e/MWh
Description	Baseline emission factor for North China Power Grid
Source of data	“2017 Baseline Emission Factors for Regional Power Grids in China” published by China DNA
Value applied	0.8405
Justification of choice of data or description of measurement methods and procedures applied	Calculated as per the latest version of “Tool to calculate the emission factor for an electricity system” (version 06.0) by China DNA
Purpose of Data	Baseline emission calculation
Comments	Calculated ex ante and fixed for the second crediting period

5.2 Data and Parameters Monitored

Data / Parameter	$EG_{facility,y}$
Data unit	MWh/yr
Description	Quantity of net electricity generation supplied by the project plants/units to the grid in year y.
Source of data	Calculated according to the equation (12) in section 5.3
Description of measurement methods and procedures to be applied	The net electricity supplied to the Grid by the project are calculated through $EG_{export,y}$, $EG_{import,y}$, $EG_{A,y}$, $EG_{B,y}$, $EG_{C,y}$ and $EG_{im-spares,y}$ according to the equation (12) in section 5.3
Frequency of monitoring/recording	-
Value applied	Estimation of annual net electricity generation delivered to grid: 118,560
Monitoring equipment	-

QA/QC procedures to be applied	Electricity supplied to the grid is checked by internal verification procedure and electricity sales receipts.
Purpose of data	Baseline emission calculation
Calculation method	Calculated according to the equation (12) in section 5.3
Comments	Uncertainty level of data is low

Data / Parameter	$EG_{\text{export},y}$
Data unit	MWh/yr
Description	Total electricity supplied to the grid via the main power line by the Project, Project B and other project(s) during year y
Source of data	Readings of electricity Meter M1 installed at the Wenduer substation (M2 as its back up Meter, installed at the high voltage of the 35kV/220kV substation at the Project site)
Description of measurement methods and procedures to be applied	Continuously measured and monthly recorded. Data are archived for 2 years following the end of the crediting period by means of electronic and paper backup.
Frequency of monitoring/recording	Continuously measured and monthly recorded
Value applied	-
Monitoring equipment	-
QA/QC procedures to be applied	The accuracy of electricity meters are 0.2s. The calibration frequency is one time/year in accordance with the national calibration standard. The data will be cross checked by sales receipt.
Purpose of data	Baseline emission calculation
Calculation method	-
Comments	Uncertainty level of data is low

Data / Parameter	$EG_{import,y}$
Data unit	MWh/yr
Description	Total electricity purchased from the grid by the Project, Project B and other project(s) during year y
Source of data	Readings of electricity Meter M1 installed at the Wenduer substation (M2 as its back up Meter, installed at the high voltage of the 35kV/220kV substation at the Project site)
Description of measurement methods and procedures to be applied	Continuously measured and monthly recorded. Data are archived for 2 years following the end of the crediting period by means of electronic and paper backup.
Frequency of monitoring/recording	Continuously measured and monthly recorded
Value applied	-
Monitoring equipment	-
QA/QC procedures to be applied	The accuracy of electricity meters is 0.2s. The calibration frequency is one time/year in accordance with the national calibration standard. The data will be cross checked by sales receipt.
Purpose of data	Baseline emission calculation
Calculation method	-
Comments	Uncertainty level of data is low

Data / Parameter	$EG_{A-i,y}$
Data unit	MWh/yr
Description	Quantity of electricity supplied to the grid by Group A-i (i=1,2,3,4) of the Project in year y.
Source of data	Readings of electricity meters (A-1, A-2, A-3 and A-4 described in B.5.3) installed at the 35kV transmission line of the Project site.

Description of measurement methods and procedures to be applied	Continuously measured and monthly recorded. Data are archived for 2 years following the end of the last crediting period by means of electronic and paper backup.
Frequency of monitoring/recording	Continuously measured and monthly recorded.
Value applied	-
Monitoring equipment	-
QA/QC procedures to be applied	The accuracy of electricity meters (A-1, A-2, A-3 and A-4) is 0.5s. The calibration frequency is one time/year in accordance with the national calibration standard.
Purpose of data	Baseline emission calculation
Calculation method	-
Comments	Uncertainty level of data is low

Data / Parameter	$EG_{B-i,y}$
Data unit	MWh/yr
Description	Quantity of electricity supplied to the grid by Group B-i (i=1,2,3,4) of the Project B in year y.
Source of data	Readings of electricity meters (B-1, B-2, B-3 and B-4 described in B.5.3) installed at the 35kV transmission line of the Project B site.
Description of measurement methods and procedures to be applied	Continuously measured and monthly recorded. Data are archived for 2 years following the end of the last crediting period by means of electronic and paper backup.
Frequency of monitoring/recording	Continuously measured and monthly recorded.
Value applied	-
Monitoring equipment	-

QA/QC procedures to be applied	The accuracy of electricity meters (B-1, B-2, B-3 and B-4) is 0.5s. The calibration frequency is one time/year in accordance with the national calibration standard.
Purpose of data	Baseline emission calculation
Calculation method	-
Comments	Uncertainty level of data is low

Data / Parameter	$EG_{C-i,y}$
Data unit	MWh/yr
Description	Quantity of electricity supplied to the grid by Group C-i (i=1,2,...,i) of the other project(s) in year y.
Source of data	Readings of electricity meters (C-1, C-2...C-i described in B.5.3) installed at the 35kV transmission line of the other project(s) site.
Description of measurement methods and procedures to be applied	Continuously measured and monthly recorded. Data are archived for 2 years following the end of the last crediting period by means of electronic and paper backup.
Frequency of monitoring/recording	Continuously measured and monthly recorded.
Value applied	-
Monitoring equipment	-
QA/QC procedures to be applied	The accuracy of electricity meters (C-1, C-2...C-i) is 0.5s. The calibration frequency is one time/year in accordance with the national calibration standard.
Purpose of data	Baseline emission calculation
Calculation method	-
Comments	Uncertainty level of data is low

Data / Parameter	EG _{im-spare,y}
Data unit	MWh/yr
Description	Total electricity purchased from the grid by the Project, Project B and Other project(s) through a spare 10 kV line in the year y
Source of data	Readings of electricity meter M3 installed on the spare 10 kV line
Description of measurement methods and procedures to be applied	Continuously measured and monthly recorded by the local power distributor. Data are archived for 2 years following the end of the last crediting period by means of electronic and paper backup.
Frequency of monitoring/recording	Continuously measured and monthly recorded.
Value applied	-
Monitoring equipment	-
QA/QC procedures to be applied	The accuracy of electricity meter is 2.0. The calibration frequency is one time/year in accordance with the national calibration standard. The data will be cross checked by sales receipt.
Purpose of data	Baseline emission calculation
Calculation method	-
Comments	Uncertainty level of data is low

5.3 Monitoring Plan

The monitoring plan of the project is designed according to the approved consolidated monitoring methodology ACM0002 “Grid-connected electricity generation from renewable sources” (version 20.0). This monitoring plan sets out a number of monitoring tasks in order to ensure the complete, consistent, clear and accurate monitoring and the accurate calculation of the emission reduction in the crediting period. This plan is mainly implemented by the project owner with the cooperation of the grid company.

1. Monitoring Object

The main objective data is the power supplied to and purchased from the grid, which is calculated according to the generated electricity and the purchased electricity and supplied to the grid, thus to calculate the emission reduction of the project.

2. Monitoring Implementers

The General Manager of the project entity appoints a VCS project manager or a chief officer. The operational and monitoring manager of the plant, the Financial Chief, and the Technical Chief are responsible for the collection of the data and information required in the monitoring plan. The collected information is documented and sent to the VCS manager or responsible staffs of the project entity monthly. The VCS manager in charge of the implementation of the Monitoring Plan and report to the General Manager of the company. The General Manager of the company makes the confirmations on monitoring, calculation data and reports.

The organization of the monitoring implementers is illustrated in the table below:

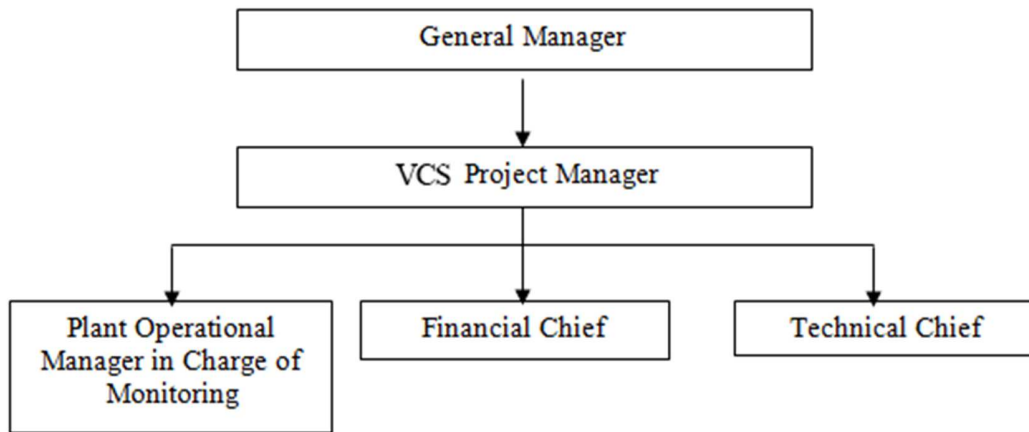

Figure 4: Monitoring structure of the project

3. Monitoring Program and Equipment

The power connection and monitoring system is shown as below:

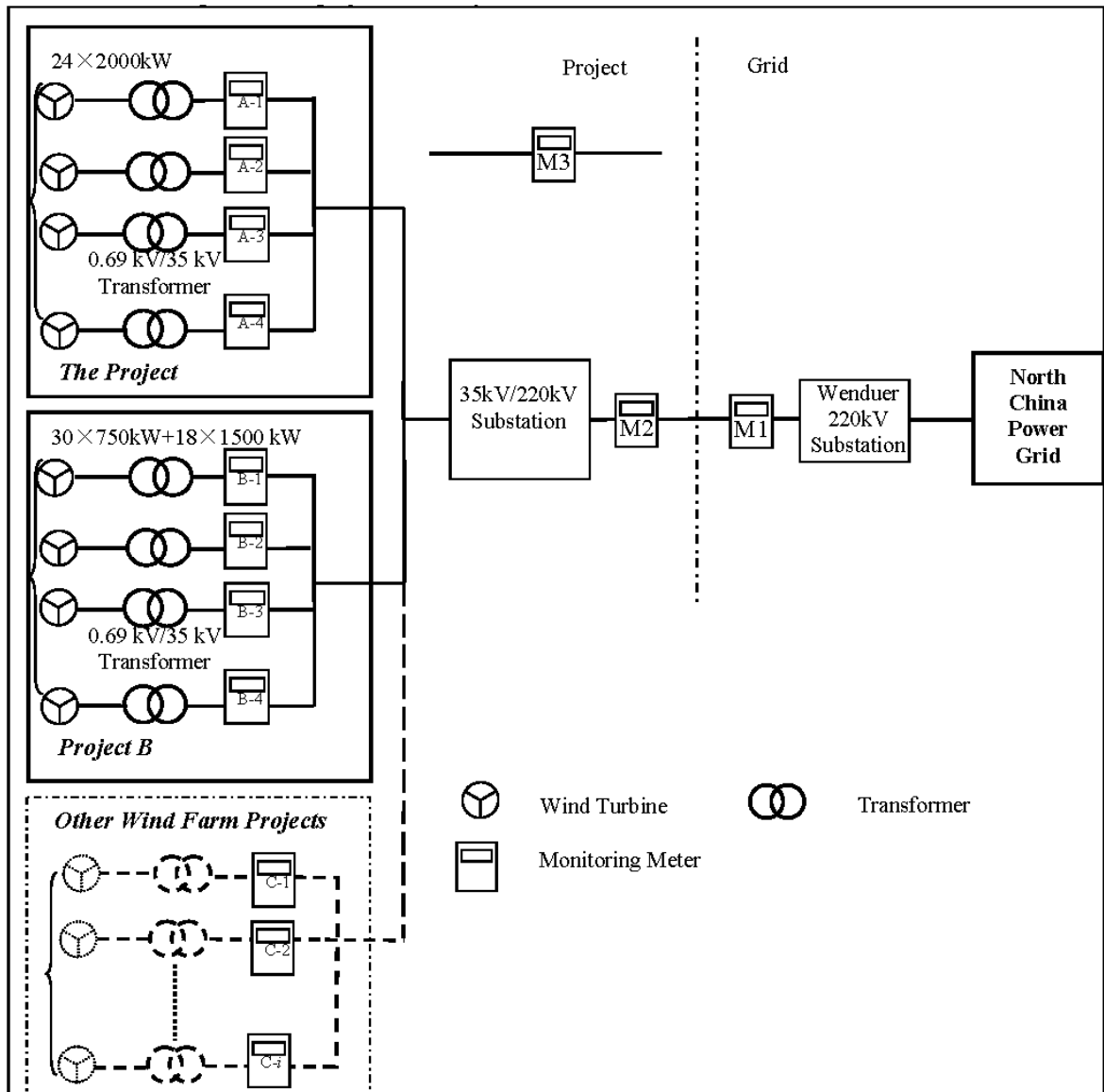

Figure 5: The location of meters

The Project shares the 35kV/220kV substation and gateway meters (M1 as the main meter and M2 as the backup meter) with Project B (Inner Mongolia Jingneng Saihan Wind Farm Phase I Project), and other project(s) (so called other project(s), of which Inner Mongolia Jingneng Saihan Wind Farm Phase III Project is in operation on 14/12/2012², and other more projects will be

² Inner Mongolia Jingneng Saihan Wind Farm Phase III Project quality supervision and inspection reports

planned for construction) which are under construction and will be connected to the 35kV/220kV substation. Before other project(s) puts into operation, monitoring equipment include M1, M2, M3, A-1, A-2, A-3, A-4, B-1, B-2, B-3 and B-4; After other project(s) puts into operation, C-1, C-2...C-i will be included in the monitoring equipment.

The main meter M1 is employed at the grid company substation and the grid company is responsible for conducting the monitoring. The backup meter M2 is equipped at the high voltage of the 35kV/220kV substation at the Project site and the project owner is responsible for conducting its monitoring. The accuracy of the meters M1 and M2 is 0.2s. At the same time, the data measured by M1 and M2 can be monitored and recorded at the on-site control centre using a computer system.

Additionally, a spare 10 kV line is used for supplying electricity to the Project, Project B and Other project(s) in emergencies. $EG_{im-spare,y}$ is measured by the meter M3 which is owned, operated and installed by local power distributor. Sales receipt will be cross-check with the meter reading. The accuracy of M3 is 2.0, which meets the national requirement. The calibration will be done in line with the national calibration standard.

The 24 sets of wind turbines of the Project were divided into 4 groups, and each group is connected with a 35kV transmission line and installed with a meter at the low voltage side of 35kV/220kV substation. These meters (A-1, A-2, A-3, A-4) are installed as the auxiliary meters to calculate the electricity supplied to the grid by Group A-i (i=1,2,3,4) of the Project. Similarly, Four meters (B-1, B-2, B-3, B-4) are installed as auxiliary meters to calculate the electricity supplied to the grid by Group B-i (i=1,2,3,4) of the Project B. The accuracy of these eight meters is 0.5s.

Moreover, considering there are other wind farm project(s) (so called other project(s), of which currently Inner Mongolia Jingneng Saihan Wind Farm Phase III Project is in operation, and other more projects will be planned for construction) , will share the 35kV/220kV substation on the Project site, the gateway meters (M1 and M2) in Wenduer 220kV substation and the M3 on a 10kV spare line, more meters (C-1, C-2,...C-i) will be installed on the 35kV transmission line at the other project(s) site to monitor the supplied electricity by other project(s). The accuracy of these meters (C-1, C-2...C-i) will be no lower than 0.5s and they will be calibrated in accordance with national standards.

In order to deal with the jointly-reading problem, the project owner and the grid company set up the procedure and calculation method to determine the net electricity supplied to the grid by the Project, which is calculated as follows:

$$EG_{facility,y} = \frac{EG_{A-i,y}}{EG_{A-i,y} + EG_{B-i,y} + EG_{C-i,y}} EG_{export,y} - EG_{import,y} - EG_{im-spare,y} \quad (12)$$

Where:

$EG_{\text{facility},y}$	=	Quantity of net electricity generation that is produced and fed into the grid as a result of the implementation of the Project activity in year y
$EG_{\text{export},y}$	=	Total electricity supplied to the grid via the main power line by the Project, Project B and other project(s) in the year y.
$EG_{\text{import},y}$	=	Total electricity purchased from the grid via the main power line by the Project, Project B and other project(s) in the year y.
$EG_{A-i,y}$	=	Electricity supplied to the grid by Group A-i (i=1,2,3,4) of the Project in the year y.
$EG_{B-i,y}$	=	Electricity supplied to the grid by Group B-i (i=1,2,3,4) of the Project B in the year y.
$EG_{C-i,y}$	=	Electricity supplied to the grid by Group C-i (i=1,2...n) of the other project(s) in the year y.
$EG_{\text{im-spare},y}$	=	Total electricity purchased from the grid by the Project, Project B and other project(s) through the spare 10 kV line in the year y.

4. Data Collection

Before other project(s) are connected to the 35kV/220kV substation at the Project site, the verification use the data of the main meter M1, the meter M3 installed on the spare 10 kV line and eight auxiliary meters on 35kV transmission line as long as the inaccuracy of these meters is within the permissible tolerance. The main procedures are as follows:

- 1) According to the requirements of power purchase/sales agreement, the project owner and the grid company should collect the data of both the main meter M1 and the backup meter M2 periodically, and check them at the same time.
- 2) For the electricity supplied to the grid by the project activity, the project owner collects and records the data of auxiliary meters and calculates the electricity supplied to the grid by the Project as per the procedure and calculation method jointly set up. Then the project owner provides sales receipt to the Grid Company. A copy of the sales receipt is stored for cross-check.
- 3) When the electricity generated by this project cannot meet the electricity requirement of the power plant, the grid company supplies the electricity to the project owner. The Grid Company provides an electricity sales receipt to the project owner and the sales receipt is stored by the project owner.
- 4) The project owner records the power supplied to and purchased from the grid as well as the electricity purchased from the spare 10 kV line, and hence calculate the net electricity supplied to the grid;

- 5) The project owner will keep the records of the main meter, the meter installed on the spare 10 kV line and the eight auxiliary meters' data readings for verification by the DOE.

In any case that any of the eight auxiliary meters on 35kV transmission line exceeds the allowable tolerance or its malfunction occurs, the project owner will give up the emission reductions during the period when any of the eight auxiliary meters are inaccurate. Otherwise, if the fault of the main meter M1 exceeds the allowable tolerance or its malfunction occurs but the eight auxiliary meters are within the allowable tolerance, the grid-connected electricity generated by the Project will be resolved by following measures:

- 1) Adopting the backup meter M2, the meter M3 installed on the spare 10 kV line and the eight auxiliary meters' data, unless a test by either party reveals it is inaccurate;
- 2) If the inaccuracy of the backup meter M2 is not within the acceptable limits or it cannot work properly, the project owner will give up the emission reductions during the period when both the main meter and the backup meter are inaccurate;

In addition, in any case that the fault of the meter M3 installed on the spare 10 kV line exceeds the allowable tolerance or its malfunction occurs, to be conservative, the project owner will apply the largest data over the years to calculate the emission reductions.

After the other project(s) connects to the shared 35kV/220kV substation at the Project site, the collection procedures of the data measured by the meter (C-1, C-2,...C-i) are similar to the above procedures of the Project and Projects B. If any meter (C-1, C-2,...C-i) exceeds the allowable tolerance or its malfunction occurs, the project owner will give up the emission reductions during the period when any of the meters (C-1, C-2,...C-i) are in malfunction.

5. Calibration of Meters & Metering

The metering equipment will be properly calibrated and checked annually for accuracy. The project owner will prepare backup procedures to deal with any errors occurred to the meters. The calibration records carried out by the grid company should be provided to the project owner, and these records will be maintained by the project owner and the third party designated.

Meters should be tested by a qualified metric organization co-authorized by the project owner and the grid company within 10 days after:

- 1) The detection of the reading difference between the main meter and the backup meter that exceeds the allowable tolerance.
- 2) The equipment's malfunction caused by improper operation

All the calibration test records should be maintained safely for the verification.

6. Data Management System

To keep safely the record of the data collected during monitoring, this project will set up a complete data management system. The project will perfect the whole monitoring procedure by developing the VCS manual, tracking information from the primary source to the end-data calculations in paper document format. It is the responsibility of the project owner to provide additional necessary data and information for validation and verification requirements of respective DOE. Physical documentation such as paper-based maps, diagrams and environmental assessment will be collated in a central place, together with this monitoring plan. All paper-based information will be stored by the project owner and kept at least one copy.

At the end of each month, the monitoring data will be filed in a spreadsheet, and the paper-based printout should be also archived. Furthermore, the project owner collects the sales receipts for the electricity supplied to the grid as a cross-check, and compiled the monitoring report including the monitoring data and relevant evidence at the end of each crediting year.

All the data will be kept for two years following the end of the last crediting period.

7. Monitoring Report

After the VCS project manager collects and sorts the monitored data, the monitoring report is prepared by the project developer. The project developer has to make sure that the format and content of the monitoring report are consistent with the monitoring methodology in the registered PD.