



Verified Carbon Standard

INNER MONGOLIA JINGNENG SAIHAN WIND FARM PHASE II PROJECT



Document Prepared by Climate Bridge (Shanghai) Ltd.

Tel: +86 21 6246 2036; Fax: +86 21 2301 9950

Project Title	Inner Mongolia Jingneng Saihan Wind Farm Phase II Project
Version	2.1
Report ID	-
Date of Issue	21-04-2021
Project ID	921
Monitoring Period	27-10-2009 to 20-09-2015
Prepared By	Siran Wu
Contact	Block B, Level 24, Jiangong Mansion, 33 Fushan Road, Pudong New Area, Shanghai, P.R. of China Telephone: 2162462036; Email: wu.siran@climatebridge.com http://www.climatebridge.com

CONTENTS

- 1 PROJECT DETAILS..... 3**
 - 1.1 Summary Description of the Implementation Status of the Project 3
 - 1.2 Sectoral Scope and Project Type 3
 - 1.3 Project Proponent 3
 - 1.4 Other Entities Involved in the Project 3
 - 1.5 Project Start Date 4
 - 1.6 Project Crediting Period 4
 - 1.7 Project Location 4
 - 1.8 Title and Reference of Methodology 6
 - 1.9 Participation under other GHG Programs 6
 - 1.10 Other Forms of Credit 6
 - 1.11 Sustainable Development 6

- 2 SAFEGUARDS 7**
 - 2.1 No Net Harm 7
 - 2.2 Local Stakeholder Consultation 7
 - 2.3 AFOLU-Specific Safeguards 9

- 3 IMPLEMENTATION STATUS 9**
 - 3.1 Implementation Status of the Project Activity 9
 - 3.2 Deviations 10
 - 3.3 Grouped Projects 10

- 4 DATA AND PARAMETERS..... 10**
 - 4.1 Data and Parameters Available at Validation 10
 - 4.2 Data and Parameters Monitored..... 11
 - 4.3 Monitoring Plan 22

- 5 QUANTIFICATION OF GHG EMISSION REDUCTIONS AND REMOVALS 28**
 - 5.1 Baseline Emissions 28
 - 5.2 Project Emissions 30
 - 5.3 Leakage..... 30
 - 5.4 Net GHG Emission Reductions and Removals..... 30

1 PROJECT DETAILS

1.1 Summary Description of the Implementation Status of the Project

Inner Mongolia Jingneng Saihan Wind Farm Phase II Project (hereinafter referred to as the project) located in Suniteyouqi, Xilinguole League, Inner Mongolia Autonomous Region, P. R. China. The project involves the installation of 24 wind turbines with capacity of 2000 kW each, which amount to a total installed capacity of 48 MW. The estimated annual net electricity supplied to the grid of the project is 118,560 MWh. The construction of the project was started on 20/06/2009, and the first wind turbine has been put into operation on 27/10/2009. All the 24 wind turbines have been put into operation on 26/12/2009. The electricity generated from the project is supplied to the North China Power Grid, by replacing the electricity generated from fossil fuel-fired power plants dominated North China Power Grid (NCPG), the project activity achieves obvious greenhouse gas (GHG) emission reductions by avoiding CO₂ emissions.

During this VCS monitoring period from 27/10/2009 to 20/09/2015 (both days included), the total emission reduction achieved is 395,987 tCO_{2e}.

1.2 Sectoral Scope and Project Type

Sectoral scope: 1. Energy (renewable/non-renewable);

Project type: Wind-power generation project;

The project is not a grouped project.

1.3 Project Proponent

Organization name	Beijing International New Energy Co., Ltd.
Contact person	Jiamao Xu
Title	Project Manager
Address	No.1, Nanbinhe Road, Guanganmenwai, Xuanwu District, 1003 Room, Gaoxin Building, Beijing City, China.
Telephone	021-23019950
Email	1169735462@qq.com

1.4 Other Entities Involved in the Project

Organization name	Climate Bridge Ltd.
--------------------------	---------------------

Role in the Project	VCU Buyer
Contact person	Zhiwen Gao
Title	General Manager
Address	Block B, Level 24, Jiangong Mansion, 33 Fushan Road, Pudong New Area, Shanghai, China 200120
Telephone	+86-2162462036
Email	gao.zhiwen@climatebridge.com

1.5 Project Start Date

The starting date of the project is 27/10/2009 (the date of project started operation).

1.6 Project Crediting Period

There is a deviation for the crediting period. The project is registered under VCS 2007.1 and completed validation before 19/03/2020, thus it remains eligible to apply the crediting period requirements under VCS Version 3 which shall be a maximum of ten years and may be renewed at most twice, so the first renewable crediting period of the project shall be updated from 27/10/2009~08/06/2011 to 27/10/2009~26/10/2019.

1.7 Project Location

The project located in Suniteyouqi, Xilinguole League, Inner Mongolia Autonomous Region, P. R. China. The project has central geographical coordinates with east longitude of 112° 51'00" and north latitude of 42° 37'00".

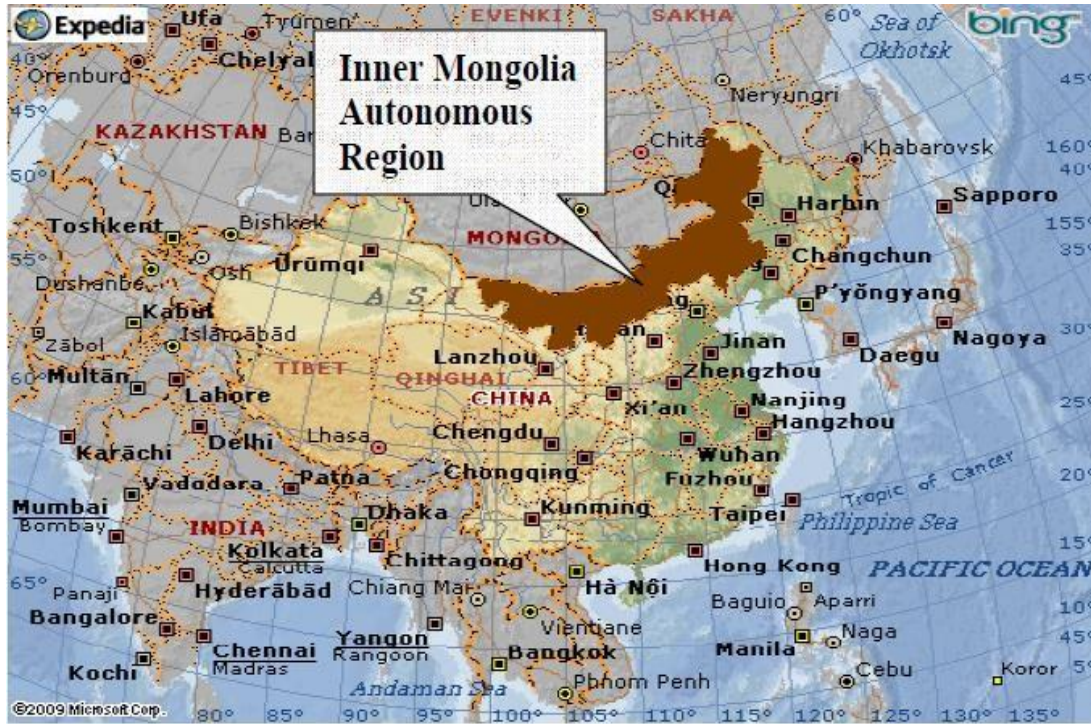

Figure 1. Location of Inner Mongolia Autonomous Region in China

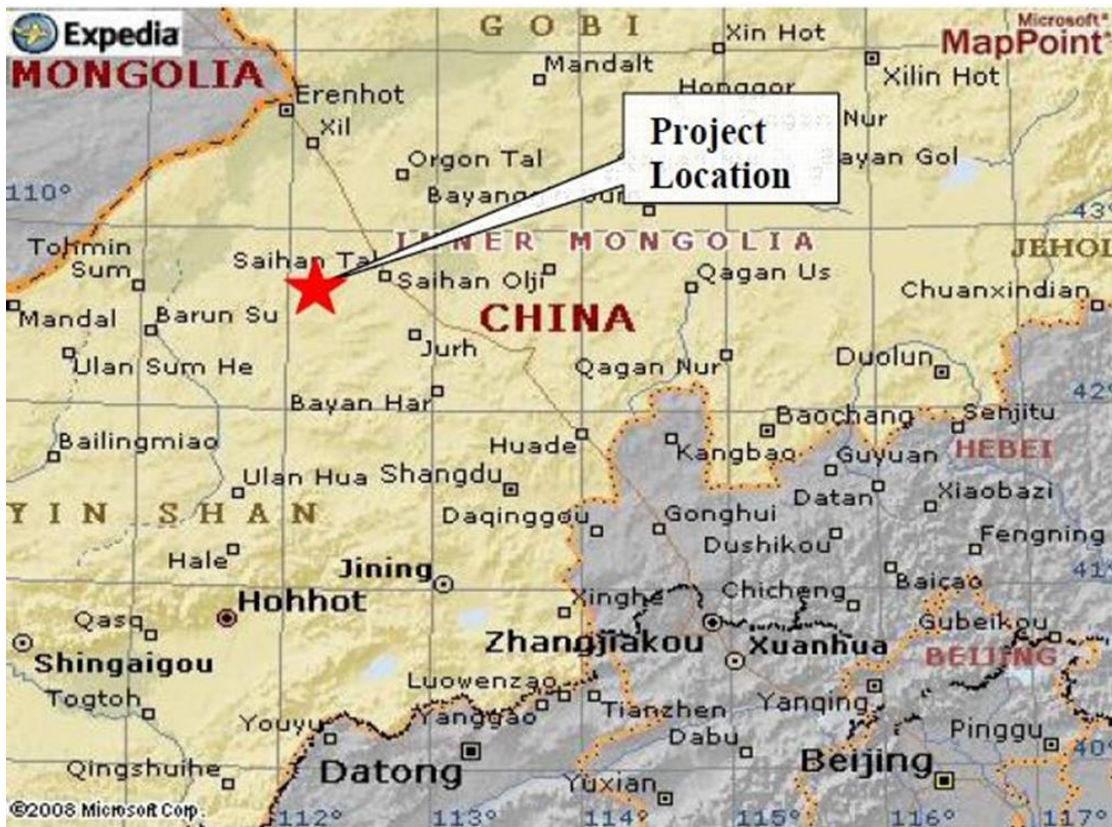

Figure 2. Location of the project

1.8 Title and Reference of Methodology

The approved methodology applied in the proposed project activity is ACM0002 (version 12.1.0) – “Consolidated methodology for grid-connected electricity generation from renewable sources” and monitoring methodology.

“Tool for the Demonstration and Assessment of Additionality (version 05.2)”

“Tool to calculate the emission factor for an electricity system (version 02.1.0)”

For more information regarding the methodology please refer to:

<http://cdm.unfccc.int/methodologies/PAmethodologies/approved.html>

1.9 Participation under other GHG Programs

The project has been registered as a Clean Development Mechanism (CDM) project in UNFCCC on 09/06/2011 (UNFCCC Ref. 4795), with the 7 years crediting period started from 09/06/2011. Total GHG emission reductions of 70,876 tCO₂ generated from 09/06/2011 to 20/05/2012 (both days included) by the project has been issued as CERs under CDM program. Please refer to the following link for details:

<https://cdm.unfccc.int/Projects/DB/BVQ11305287203.94/view?cp=1>

Except for CDM, the project did not register under any other GHG program.

1.10 Other Forms of Credit

Total GHG emission reductions of 70,876 tCO₂ generated from 09/06/2011 to 20/05/2012 (both days included) by the project has been issued as CER under CDM program

The GHG emission reductions generated by the project from 27/10/2009 to 20/09/2015 will not be used for compliance with emission trading programs or to meet binding limits on GHG emissions.

All credits from 27/10/2009 to 20/09/2015 will be claimed under VCS program as VCU for the project to avoid double counting.

The project hasn't sought or received another form of environmental credits.

1.11 Sustainable Development

The project makes contribution to the local sustainable development as follows:

GHG emission reduction

The project will help reduce the greenhouse gas GHG emissions versus the high-growth, coal-dominated business-as-usual scenario in the North China Power Grid by reducing the electricity generation from the fossil-fuel fired power plants, particularly the emission of SO_x, NO_x and dust.

Employment opportunities

The conducting of the project will offer job opportunities for local people, the estimated temporary job created in construction period and long-term job in the operational period are about 300 and 24, respectively.

Economic Improvement

The construction of the wind farm will promote local economy by contributing to local government with more tax revenues through selling power generation.

2 SAFEGUARDS

2.1 No Net Harm

There are no negative environmental and/or socio-economic impacts due to the project. In fact, the project as a clean renewable energy project can reduce greenhouse gas emissions and the environmental pollution caused by fossil fuels consumption. Meanwhile, the implementation of the project will improve local socio-economic development through creating career opportunities and paying taxes.

2.2 Local Stakeholder Consultation

Local Stakeholder Consultation during the project preparation stage:

On 21/03/2009, staff from the project owner carried out a survey of the local resident around the project location. The staff introduced the background of the project and then sent out 50 copies of questionnaire in a random way, 46 pieces of reply were received. Among the interviewees, 23 of them are governmental officials, 8 teachers, 3 workers, 1 student, 1 farmer and 10 others.

An invitation notice for stakeholder comments was later issued by the project developer, 23 representatives of local stakeholders, including governmental officials of local county and local resident, etc attended the meeting on 21/03/2009 to discuss the questionnaires collected and further introduce the project. No negative opinion on construction of the project is heard and environmental considerations expressed by stakeholders are discussed on the meeting.

The questions regarding the project were mainly as follows:

1. How is the current environment quality?

2. Do you currently experience electromagnetic interference when watching TV at home?
3. Are there any negative impacts of the project on the everyday life of local residents?
4. Is the project going to help improve the local economy?
5. Does the project impact on local sound/noise environment?
6. Which is the environmental topic that concerns you the most during the construction and operation of the project?
7. Do you support the project?

The summary of survey is listed as the following:

- 35 (76%) of them think the current environment quality is good, 10 (22%) think it is normal and 1 (2%) of them are unsure;
- 26 (57%) of them doesn't experience electromagnetic interference, 14 (30%) experiences and 6(13%) of them are not sure;
- 32 (70%) of them think there will not be any negative impacts on their everyday life, 7(15%) of them thinks there will be and 7(15%) of them are not sure;
- 42 (91%) of them think the project will help to improve the local economy, none of them don't think so and 4(9%) of them are not sure;
- 22 (48%) of them think the project doesn't impact on local sound/noise environment, 4 (9%) of them think it will, 20 (43%) of them are unsure;
- Regarding the construction and operation of the propose project, 20 (43%) of them are most concerned with the noise level and 23 (50%) of them are most concerned with wastewater;
- 45 (98%) of them support the implementation of the project and 1 (2%) of them don't care.

Conclusion: The local community possesses basically positive comments on the effects of the project. The interviewees considered that local social, economic and environmental development would be beneficial from the project. The response was overall supportive to the project implementation

Local Stakeholder Consultation during the project implementation stage:

Communications with Local stakeholders were carried out at periodic intervals. Key implementation schedules or changes of the project will be communicated to the local authority, who will inform the neighbourhood committee and the local residents, the comments and suggestions from residents will be collected by the local authority meanwhile. And the local

government agencies and competent authorities will conduct spot checks on the implementation of the project from time to time, and give suggestions on the involved rectification problems. There are no negative comments received for the project. In line with VCS requirements all the processes have been implemented to receive comments from local stakeholders as well as communicate with them at periodic intervals.

2.3 AFOLU-Specific Safeguards

NA

3 IMPLEMENTATION STATUS

3.1 Implementation Status of the Project Activity

The project involves the installation of 24 wind turbines with capacities of 2000 kW each, which amount to a total installed capacity of 48MW, and the project started operation on 27/10/2009. There was no significant malfunction or any emergency reported for the Project during this VCS monitoring period from 27/10/2009 to 20/09/2015.

The wind turbines were supplied by Beijing Beizhong Steam Turbine Generator Co., Ltd. And the selected model is FD80-2000. The main technical specifications of the wind turbine are provided in the following table.

Table 1 The main technical specification

Item	Unit	Index
Rated capacity	kW	2000
Number of blades	piece	3
Rotor diameter	m	80
Rated wind speed	m/s	13.5
Rated Power	kW	2000
Rated voltage	V	690
Life time	Year	20
Plant load Factor	-	0.28

3.2 Deviations

3.2.1 Methodology Deviations

As plant specific fuel consumption and electricity generation data are not publicly available in China, the Guidance caused by DNV's request for deviation of Chinese project activities for the baseline methodology AM0005 has been applied for calculating the build margin (BM) emission factor of this project activity.

Moreover, the result of BM and OM are sourced from local government.

The deviation has no impact on conservativeness of the quantification of GHG emission reductions or removals.

3.2.2 Project Description Deviations

There is a deviation for the crediting period. The project is registered under VCS 3 and completed validation before 19/03/2020, thus it remains eligible to apply the crediting period requirements under VCS version 03 which shall be a maximum of ten years and may be renewed at most twice. Therefore, the first renewable crediting period of the project shall be updated from 27/10/2009 ~08/06/2011 to 27/10/2009 ~26/10/2019 (10 years).

3.3 Grouped Projects

The Project is not a grouped project.

4 DATA AND PARAMETERS

4.1 Data and Parameters Available at Validation

In this monitoring report, there is only one parameter $EF_{grid,CM,y}$ available at validation, which is different from the registered PDD. The reason is that the parameter $EF_{grid,CM,y}$ is calculated by the data and parameters available at validation in the registered PDD ($FC_{i,m,y}$, NCV_i , $EF_{CO2,i,y}$, Carbon Oxidation Factor, Installed Capacity, GENy, Efficiency of the best technology commercially). Thus, the only one parameter $EF_{grid,CM,y}$ is simplified in this monitoring report.

Data / Parameter	$EF_{grid,CM,y}$
Data unit	tCO ₂ e/MWh
Description	Baseline emission factor for North China Power Grid
Source of data	Registered CDM PDD
Value applied	0.9502

Justification of choice of data or description of measurement methods and procedures applied	-
Purpose of Data	Calculation of baseline emissions
Comments	The baselines emission factor was determined ex-ante and fixed during the first crediting period.

4.2 Data and Parameters Monitored

The Project shares the 35kV/220kV substation and gateway meters (M1 as the main meter and M2 as the backup meter) with Project B (Inner Mongolia Jingneng Saihan Wind Farm Phase I Project), and other project(s) (Inner Mongolia Jingneng Saihan Wind Farm Phase III Project). In order to deal with the jointly-reading problem, the project owner and the grid company set up the procedure and calculation method to determine the net electricity supplied to the grid by the Project, which is calculated according to the equation (1) in section 4.3.

Data / Parameter	$EG_{\text{facility},y}$								
Data unit	MWh								
Description	Quantity of net electricity generation supplied by the project to the Grid in year y .								
Source of data	Calculated according to the equation (1) in section 4.3								
Description of measurement methods and procedures to be applied	The net electricity supplied to the Grid by the project are is calculated through $EG_{\text{export},y}$, $EG_{\text{import},y}$, $EG_{A,y}$, $EG_{B,y}$, $EG_{C,y}$ and $EG_{\text{im-spare},y}$ according to the equation (1) in section 4.3 equation (12) in section 5.3								
Frequency of monitoring/recording	-								
Value applied	<table border="1"> <thead> <tr> <th>Year</th> <th>Value</th> </tr> </thead> <tbody> <tr> <td>27/10/2009-31/12/2009</td> <td>0.00¹</td> </tr> <tr> <td>01/01/2010-31/12/2010</td> <td>88,436.04</td> </tr> <tr> <td>01/01/2011-08/06/2011</td> <td>52,420.41</td> </tr> </tbody> </table>	Year	Value	27/10/2009-31/12/2009	0.00 ¹	01/01/2010-31/12/2010	88,436.04	01/01/2011-08/06/2011	52,420.41
Year	Value								
27/10/2009-31/12/2009	0.00 ¹								
01/01/2010-31/12/2010	88,436.04								
01/01/2011-08/06/2011	52,420.41								

¹ Although the project started trial operation on 27/10/2009, due to unstable operation, the project was suspended for adjustment until it resumed operation in April of year 2010.

	09/06/2011-20/05/2012	0.00 ²
	21/05/2012-31/12/2012	50,219.20
	01/01/2013-31/12/2013	83,137.55
	01/01/2014-31/12/2014	83,808.92
	01/01/2015-20/09/2015	58,721.35
	Total	416,743.47
Monitoring equipment	-	
QA/QC procedures to be applied	Power supplied to the grid will be checked by internal verification procedure and electricity sales receipts.	
Purpose of data	Baseline emission calculation	
Calculation method	Calculated according to the equation (1) in section 4.3	
Comments	Uncertainty level of data is low	

Data / Parameter	EG _{export,y}					
Data unit	MWh					
Description	Total electricity supplied to the grid via the main power line by the Project, Project B and other project(s) during year y					
Source of data	Readings of electricity Meter M1 installed at the Wenduer substation (M2 as its back up Meter, installed at the high voltage of the 35kV/220kV substation at the Project site)					
Description of measurement methods and procedures to be applied	Continuously measured and monthly recorded. Data are archived for 2 years following the end of the crediting period.					
Frequency of monitoring/recording	Continuously measured and monthly recorded					
Value applied	<table border="1"> <thead> <tr> <th>Year</th> <th>Value</th> </tr> </thead> <tbody> <tr> <td>27/10/2009-31/12/2009</td> <td>31,843.04</td> </tr> </tbody> </table>		Year	Value	27/10/2009-31/12/2009	31,843.04
Year	Value					
27/10/2009-31/12/2009	31,843.04					

² Since the electricity generated during the periods of 09/06/2011-20/05/2012 has been issued as CERs, the electricity during this period need to be excluded.

	01/01/2010-31/12/2010	236,128.79		
	01/01/2011-08/06/2011	108,556.43		
	09/06/2011-20/05/2012	0.00 ³		
	21/05/2012-31/12/2012	114,400.64		
	01/01/2013-31/12/2013	325,842.43		
	01/01/2014-31/12/2014	291,608.30		
	01/01/2015-20/09/2015	189,104.81		
	Total	1,297,484.44		
Monitoring equipment		Main meter (M1)	Backup meter (M2)	
	Meter Type	ZMQ202C	ZMQ202C	
	Accuracy class	0.2S	0.2S	
	Serial No.	95303611	95303617	
	Calibration frequency	annually	annually	
		Serial No.	Calibration Date	Validity
			17/06/2009	16/06/2010
			16/06/2010	15/06/2011
			15/06/2011	14/06/2012
		95303611 95303617	14/06/2012	13/06/2013
		13/06/2013	12/06/2014	
		12/06/2014	11/06/2015	
		11/06/2015	10/06/2016	
QA/QC procedures to be applied	The data is checked by internal verification procedure. The data will be cross checked by sales receipt.			
Purpose of data	Baseline emission calculation			

³ Since the electricity generated during the periods of 09/06/2011-20/05/2012 has been issued as CERs, the electricity during this period need to be excluded.

Calculation method	-																						
Comments	The reading from the main meter is first choice. When the main meter is out of order, the reading from the backup meter will be used.																						
Data / Parameter	EG _{import,y}																						
Data unit	MWh																						
Description	Total electricity imported from the grid by the Project, Project B and other project(s) in year y.																						
Source of data	The readings of the main meter M1 installed at the Wenduer 220kV substation (M2 as its back up Meter, installed at the high voltage of the 35kV/220kV substation at the Project site)																						
Description of measurement methods and procedures to be applied	Continuously measured and monthly recorded. Data could be archived for 2 years following the end of the crediting period.																						
Frequency of monitoring/recording	Continuously measured and monthly recorded																						
Value applied	<table border="1"> <thead> <tr> <th>Year</th> <th>Value</th> </tr> </thead> <tbody> <tr> <td>27/10/2009-31/12/2009</td> <td>117.49</td> </tr> <tr> <td>01/01/2010-31/12/2010</td> <td>632.85</td> </tr> <tr> <td>01/01/2011-08/06/2011</td> <td>427.19</td> </tr> <tr> <td>09/06/2011-20/05/2012</td> <td>0.00⁴</td> </tr> <tr> <td>21/05/2012-31/12/2012</td> <td>440.73</td> </tr> <tr> <td>01/01/2013-31/12/2013</td> <td>928.32</td> </tr> <tr> <td>01/01/2014-31/12/2014</td> <td>1,015.73</td> </tr> <tr> <td>01/01/2015-20/09/2015</td> <td>417.53</td> </tr> <tr> <td>Total</td> <td>3,979.84</td> </tr> </tbody> </table>			Year	Value	27/10/2009-31/12/2009	117.49	01/01/2010-31/12/2010	632.85	01/01/2011-08/06/2011	427.19	09/06/2011-20/05/2012	0.00 ⁴	21/05/2012-31/12/2012	440.73	01/01/2013-31/12/2013	928.32	01/01/2014-31/12/2014	1,015.73	01/01/2015-20/09/2015	417.53	Total	3,979.84
Year	Value																						
27/10/2009-31/12/2009	117.49																						
01/01/2010-31/12/2010	632.85																						
01/01/2011-08/06/2011	427.19																						
09/06/2011-20/05/2012	0.00 ⁴																						
21/05/2012-31/12/2012	440.73																						
01/01/2013-31/12/2013	928.32																						
01/01/2014-31/12/2014	1,015.73																						
01/01/2015-20/09/2015	417.53																						
Total	3,979.84																						
Monitoring equipment	<table border="1"> <thead> <tr> <th></th> <th>Main meter (M1)</th> <th>Backup meter (M2)</th> </tr> </thead> <tbody> <tr> <td>Meter Type</td> <td>ZMQ202C</td> <td>ZMQ202C</td> </tr> <tr> <td>Accuracy class</td> <td>0.2S</td> <td>0.2S</td> </tr> </tbody> </table>				Main meter (M1)	Backup meter (M2)	Meter Type	ZMQ202C	ZMQ202C	Accuracy class	0.2S	0.2S											
	Main meter (M1)	Backup meter (M2)																					
Meter Type	ZMQ202C	ZMQ202C																					
Accuracy class	0.2S	0.2S																					

⁴ Since the electricity generated during the periods of 09/06/2011-20/05/2012 has been issued as CERs, the electricity during this period need to be excluded.

	Serial No.	95303611	95303617
	Calibration frequency	annually	annually
	Serial No.	Calibration Date	
	95303611 95303617	17/06/2009	16/06/2010
		16/06/2010	15/06/2011
		15/06/2011	14/06/2012
		14/06/2012	13/06/2013
		13/06/2013	12/06/2014
		12/06/2014	11/06/2015
		11/06/2015	10/06/2016
QA/QC procedures to be applied	The data is checked by internal verification procedure. The data will be cross checked by sales receipt.		
Purpose of data	Baseline emission calculation		
Calculation method	-		
Comments	The reading from the main meter is first choice. When the main meter is out of order, the reading from the backup meter will be used.		

Data / Parameter	EG _{A-i,y}
Data unit	MWh
Description	Quantity of electricity supplied to the grid by Group A-i (i=1,2,3,4) of the Project in year y.
Source of data	Readings of electricity meters (A-1, A-2, A-3 and A-4 described in section 5.3) installed at the 35kV transmission line of the Project site.
Description of measurement methods	Continuously measured and monthly recorded. Data are archived for 2 years following the end of the last crediting period by means

and procedures to be applied	of electronic and paper backup. The accuracy of electricity meters (A-1, A-2, A-3 and A-4) is 0.5s. The calibration frequency is once a year.																																											
Frequency of monitoring/recording	Continuously measured and monthly recorded.																																											
Value applied	<table border="1"> <thead> <tr> <th>Year</th> <th colspan="3">Value</th> </tr> </thead> <tbody> <tr> <td>27/10/2009-31/12/2009</td> <td colspan="3">0.00⁵</td> </tr> <tr> <td>01/01/2010-31/12/2010</td> <td colspan="3">90,468.11</td> </tr> <tr> <td>01/01/2011-08/06/2011</td> <td colspan="3">53,434.87</td> </tr> <tr> <td>09/06/2011-20/05/2012</td> <td colspan="3">0.00⁶</td> </tr> <tr> <td>21/05/2012-31/12/2012</td> <td colspan="3">51,454.19</td> </tr> <tr> <td>01/01/2013-31/12/2013</td> <td colspan="3">85,162.55</td> </tr> <tr> <td>01/01/2014-31/12/2014</td> <td colspan="3">86,037.33</td> </tr> <tr> <td>01/01/2015-20/09/2015</td> <td colspan="3">60,142.01</td> </tr> <tr> <td>Total</td> <td colspan="3">426,699.05</td> </tr> </tbody> </table>				Year	Value			27/10/2009-31/12/2009	0.00 ⁵			01/01/2010-31/12/2010	90,468.11			01/01/2011-08/06/2011	53,434.87			09/06/2011-20/05/2012	0.00 ⁶			21/05/2012-31/12/2012	51,454.19			01/01/2013-31/12/2013	85,162.55			01/01/2014-31/12/2014	86,037.33			01/01/2015-20/09/2015	60,142.01			Total	426,699.05		
Year	Value																																											
27/10/2009-31/12/2009	0.00 ⁵																																											
01/01/2010-31/12/2010	90,468.11																																											
01/01/2011-08/06/2011	53,434.87																																											
09/06/2011-20/05/2012	0.00 ⁶																																											
21/05/2012-31/12/2012	51,454.19																																											
01/01/2013-31/12/2013	85,162.55																																											
01/01/2014-31/12/2014	86,037.33																																											
01/01/2015-20/09/2015	60,142.01																																											
Total	426,699.05																																											
Monitoring equipment	<table border="1"> <thead> <tr> <th></th> <th>Meter A-1</th> <th>Meter A-2</th> <th>Meter A-3</th> <th>Meter A-4</th> </tr> </thead> <tbody> <tr> <td>Meter Type</td> <td>DTSD341</td> <td>DTSD341</td> <td>DTSD341</td> <td>DTSD341</td> </tr> <tr> <td>Accuracy class</td> <td>0.5S</td> <td>0.5S</td> <td>0.5S</td> <td>0.5S</td> </tr> <tr> <td>Serial No.</td> <td>4690001</td> <td>4690002</td> <td>4690003</td> <td>4690004</td> </tr> <tr> <td>Calibration frequency</td> <td>annually</td> <td>annually</td> <td>annually</td> <td>annually</td> </tr> </tbody> </table> <table border="1"> <thead> <tr> <th>Serial No.</th> <th>Calibration Date</th> <th>Validity</th> </tr> </thead> <tbody> <tr> <td></td> <td>17/06/2009</td> <td>16/06/2010</td> </tr> <tr> <td></td> <td>16/06/2010</td> <td>15/06/2011</td> </tr> </tbody> </table>					Meter A-1	Meter A-2	Meter A-3	Meter A-4	Meter Type	DTSD341	DTSD341	DTSD341	DTSD341	Accuracy class	0.5S	0.5S	0.5S	0.5S	Serial No.	4690001	4690002	4690003	4690004	Calibration frequency	annually	annually	annually	annually	Serial No.	Calibration Date	Validity		17/06/2009	16/06/2010		16/06/2010	15/06/2011						
	Meter A-1	Meter A-2	Meter A-3	Meter A-4																																								
Meter Type	DTSD341	DTSD341	DTSD341	DTSD341																																								
Accuracy class	0.5S	0.5S	0.5S	0.5S																																								
Serial No.	4690001	4690002	4690003	4690004																																								
Calibration frequency	annually	annually	annually	annually																																								
Serial No.	Calibration Date	Validity																																										
	17/06/2009	16/06/2010																																										
	16/06/2010	15/06/2011																																										

⁵ Although the project started trial operation on 27/10/2009, due to unstable operation, the project was suspended for adjustment until it resumed operation in April of year 2010.

⁶ Since the electricity generated during the periods of 09/06/2011-20/05/2012 has been issued as CERs, the electricity during this period need to be excluded.

		15/06/2011	14/06/2012
	4690001	14/06/2012	13/06/2013
	4690002	13/06/2013	12/06/2014
	4690003	12/06/2014	11/06/2015
	4690004	11/06/2015	10/06/2016
QA/QC procedures to be applied	The accuracy of electricity meters (A-1, A-2, A-3 and A-4) is 0.5s. The calibration frequency is one time/year in accordance with the national calibration standard.		
Purpose of data	Baseline emission calculation		
Calculation method	-		
Comments	The metering equipment at the 35kV transmission line are calibrated once a year according to the national calibration standard.		

Data / Parameter	$EG_{B-i,y}$					
Data unit	MWh					
Description	Quantity of electricity supplied to the grid by Group B-i (i=1,2,3,4) of the Project B in year y.					
Source of data	Readings of electricity meters (B-1, B-2, B-3 and B-4 described in section 5.3) installed at the 35kV transmission line of the Project B site.					
Description of measurement methods and procedures to be applied	Continuously measured and monthly recorded. Data are archived for 2 years following the end of the last crediting period by means of electronic and paper backup. The accuracy of electricity meters (B-1, B-2, B-3 and B-4) is 0.5s. The calibration frequency is once a year					
Frequency of monitoring/recording	Continuously measured and monthly recorded.					
Value applied	<table border="1"> <thead> <tr> <th>Year</th> <th>Value</th> </tr> </thead> <tbody> <tr> <td>27/10/2009-31/12/2009</td> <td>33,030.89</td> </tr> </tbody> </table>		Year	Value	27/10/2009-31/12/2009	33,030.89
Year	Value					
27/10/2009-31/12/2009	33,030.89					

	01/01/2010-31/12/2010	149,277.06			
	01/01/2011-08/06/2011	56,297.21			
	09/06/2011-20/05/2012	0.00 ⁷			
	21/05/2012-31/12/2012	58,566.97			
	01/01/2013-31/12/2013	118,136.04			
	01/01/2014-31/12/2014	99,777.27			
	01/01/2015-20/09/2015	59,116.51			
	Total	574,201.96			
Monitoring equipment		Meter B-1	Meter B-2	Meter B-3	Meter B-4
	Meter Type	DTSD341	DTSD341	DTSD341	DTSD341
	Accuracy class	0.5S	0.5S	0.5S	0.5S
	Serial No.	9020390	9020463	9020465	9020392
	Calibration frequency	annually	annually	annually	annually
	Serial No.	Calibration Date		Validity	
	9020390 9020463 9020465 9020392	17/06/2009		16/06/2010	
		16/06/2010		15/06/2011	
		15/06/2011		14/06/2012	
		14/06/2012		13/06/2013	
		13/06/2013		12/06/2014	
		12/06/2014		11/06/2015	
		11/06/2015		10/06/2016	
QA/QC procedures to be applied	The accuracy of electricity meters (B-1, B-2, B-3 and B-4) is 0.5s. The calibration frequency is one time/year in accordance with the national calibration standard.				

⁷ Since the electricity generated during the periods of 09/06/2011-20/05/2012 has been issued as CERs, the electricity during this period need to be excluded.

Purpose of data	Baseline emission calculation
Calculation method	-
Comments	The metering equipment at the 35kV transmission line are calibrated once a year according to the national calibration standard.

Data / Parameter	$EG_{C-i,y}$																				
Data unit	MWh																				
Description	Quantity of electricity supplied to the grid by Group C-i ($i=1,2,\dots,n$) of other project(s) in year y.																				
Source of data	Readings of electricity meters (C-1, C-2...C-i described in section 5.3) installed at the 35kV transmission line of the other project(s) site.																				
Description of measurement methods and procedures to be applied	Continuously measured and monthly recorded. Data are archived for 2 years following the end of the last crediting period by means of electronic and paper backup. The accuracy of electricity meters (C-1, C-2...C-i) will be no lower than 0.5s. The calibration frequency is once a year.																				
Frequency of monitoring/recording	Continuously measured and monthly recorded.																				
Value applied	<table border="1"> <thead> <tr> <th>Year</th> <th>Value</th> </tr> </thead> <tbody> <tr> <td>27/10/2009-31/12/2009</td> <td>0.00</td> </tr> <tr> <td>01/01/2010-31/12/2010</td> <td>0.00</td> </tr> <tr> <td>01/01/2011-08/06/2011</td> <td>0.00</td> </tr> <tr> <td>09/06/2011-20/05/2012⁸</td> <td>0.00</td> </tr> <tr> <td>21/05/2012-31/12/2012</td> <td>6,124.80</td> </tr> <tr> <td>01/01/2013-31/12/2013</td> <td>126,660.71</td> </tr> <tr> <td>01/01/2014-31/12/2014</td> <td>109,744.20</td> </tr> <tr> <td>01/01/2015-20/09/2015</td> <td>72,946.28</td> </tr> <tr> <td>Total</td> <td>315,476.00</td> </tr> </tbody> </table>	Year	Value	27/10/2009-31/12/2009	0.00	01/01/2010-31/12/2010	0.00	01/01/2011-08/06/2011	0.00	09/06/2011-20/05/2012 ⁸	0.00	21/05/2012-31/12/2012	6,124.80	01/01/2013-31/12/2013	126,660.71	01/01/2014-31/12/2014	109,744.20	01/01/2015-20/09/2015	72,946.28	Total	315,476.00
Year	Value																				
27/10/2009-31/12/2009	0.00																				
01/01/2010-31/12/2010	0.00																				
01/01/2011-08/06/2011	0.00																				
09/06/2011-20/05/2012 ⁸	0.00																				
21/05/2012-31/12/2012	6,124.80																				
01/01/2013-31/12/2013	126,660.71																				
01/01/2014-31/12/2014	109,744.20																				
01/01/2015-20/09/2015	72,946.28																				
Total	315,476.00																				

⁸ Inner Mongolia Jingneng Saihan Wind Farm Phase III Project is in operation on 14/12/2012, proved by the quality supervision and inspection reports

Monitoring equipment	Meter C-1	Meter C-2	Meter C-3	Meter C-4	
	Meter Type	DTSD341	DTSD341	DTSD341	DTSD341
	Accuracy class	0.5S	0.5S	0.5S	0.5S
	Serial No.	2873616	2873617	2873618	2873619
	Calibration frequency	annually	annually	annually	annually

Serial No.	Calibration Date	Validity
2873616 2873617 2873618 2873619	14/06/2012	13/06/2013
	13/06/2013	12/06/2014
	12/06/2014	11/06/2015
	11/06/2015	10/06/2016

QA/QC procedures to be applied	The metering equipment at the 35kV transmission line are calibrated once a year according to the national calibration standard.
Purpose of data	Baseline emission calculation
Calculation method	-
Comments	Uncertainty level of data is low

Data / Parameter	$EG_{im-spare,y}$
Data unit	MWh
Description	Total electricity purchased from the grid by the Project, Project B and Other project(s) through a spare 10 kV line in the year y
Source of data	Electricity meter reading (M3 installed on the spare 10 kV line)
Description of measurement methods and procedures to be applied	The local power distributor measures the $EG_{im-spare,y}$ by metering instrument owned, operated and installed by local power distributor. Only the owner is accessible to the meter. Electricity sales receipts will be issued accordingly in an approach which is agreed by both local power distributor and the project owner. The accuracy of the meter M3 is 2.0. The calibration frequency is once a year.
Frequency of monitoring/recording	Continuously measured and monthly recorded.

Value applied

Since the electricity generated during the periods of 09/06/2011-20/05/2012 has been issued as CERs, the electricity during this period need to be excluded. After exclusion, the $EG_{im-spare,y}$ is listed below:

Year	Value
27/10/2009-31/12/2009	5.92
01/01/2010-31/12/2010	34.57
01/01/2011-08/06/2011	14.77
09/06/2011-20/05/2012	0.00 ⁹
21/05/2012-31/12/2012	21.06
01/01/2013-31/12/2013	34.11
01/01/2014-31/12/2014	62.68
01/01/2015-20/09/2015	33.13
Total	206.25

Monitoring equipment

	Meter M3
Meter Type	DS862-4
Accuracy class	2.0
Serial No.	10669106
Calibration frequency	annually

Serial No.	Calibration	
	Date	Validity
10669106	17/06/2009	16/06/2010
	16/06/2010	15/06/2011
	15/06/2011	14/06/2012
	14/06/2012	13/06/2013
	13/06/2013	12/06/2014
	12/06/2014	11/06/2015
	11/06/2015	10/06/2016

⁹ Since the electricity generated during the periods of 09/06/2011-20/05/2012 has been issued as CERs, the electricity during this period need to be excluded.

QA/QC procedures to be applied	Reading recording, operation and maintenance of this meter was implemented by local power distributor (the owner of the metering instrument). The data will be cross checked by sales receipt
Purpose of data	Baseline emission calculation
Calculation method	-
Comments	Additionally, a spare 10 kV line is used for supplying electricity to the Project, Project B and Other project(s) in emergencies. $EG_{im-spare,y}$ is measured by the meter M3 which is owned, operated and installed by local power distributor

4.3 Monitoring Plan

The monitoring plan of the project is designed according to the approved consolidated monitoring methodology ACM0002 “Grid-connected electricity generation from renewable sources” (version 12.1.0). This Monitoring plan sets out a number of monitoring tasks in order to ensure the complete, consistent, clear and accurate monitoring and the accurate calculation of the emission reduction in the crediting period. This plan is mainly implemented by the project owner with the cooperation of the grid company.

1. Monitoring Object

The main objective data is the power supplied to and purchased from the grid, which is calculated according to the generated electricity and the purchased electricity and supplied to the grid, thus to calculate the emission reduction of the project.

2. Monitoring Implementers

The General Manager of the project entity appoints a VCS project manager or a chief officer. The operational and monitoring manager of the plant, the Financial Chief, and the Technical Chief are responsible for the collection of the data and information required in the monitoring plan. The collected information is documented and sent to the VCS manager or responsible staffs of the project entity monthly. The VCS manager in charge of the implementation of the Monitoring Plan and report to the General Manager of the company. The General Manager of the company makes the confirmations on monitoring, calculation data and reports.

The organization of the monitoring implementers is illustrated in the table below:

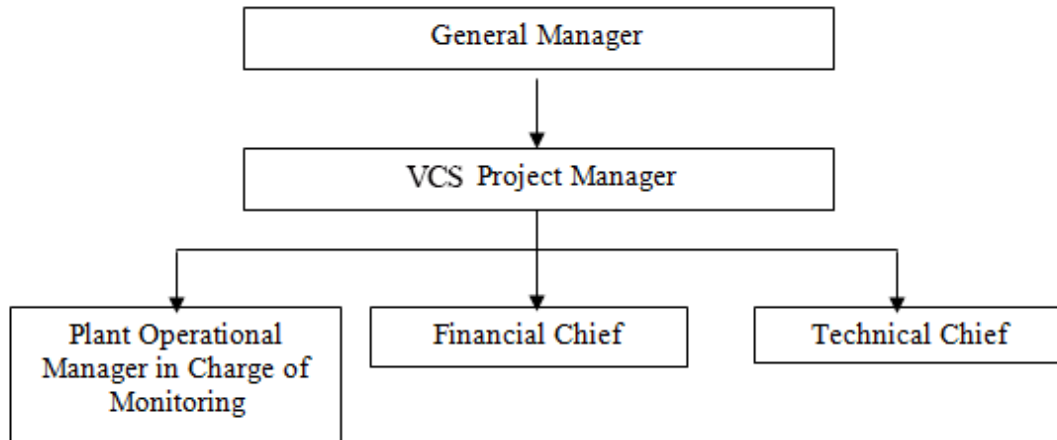

Figure 3: Monitoring structure of the project

3. Monitoring Program and Equipment

The power connection and monitoring system is shown as below:

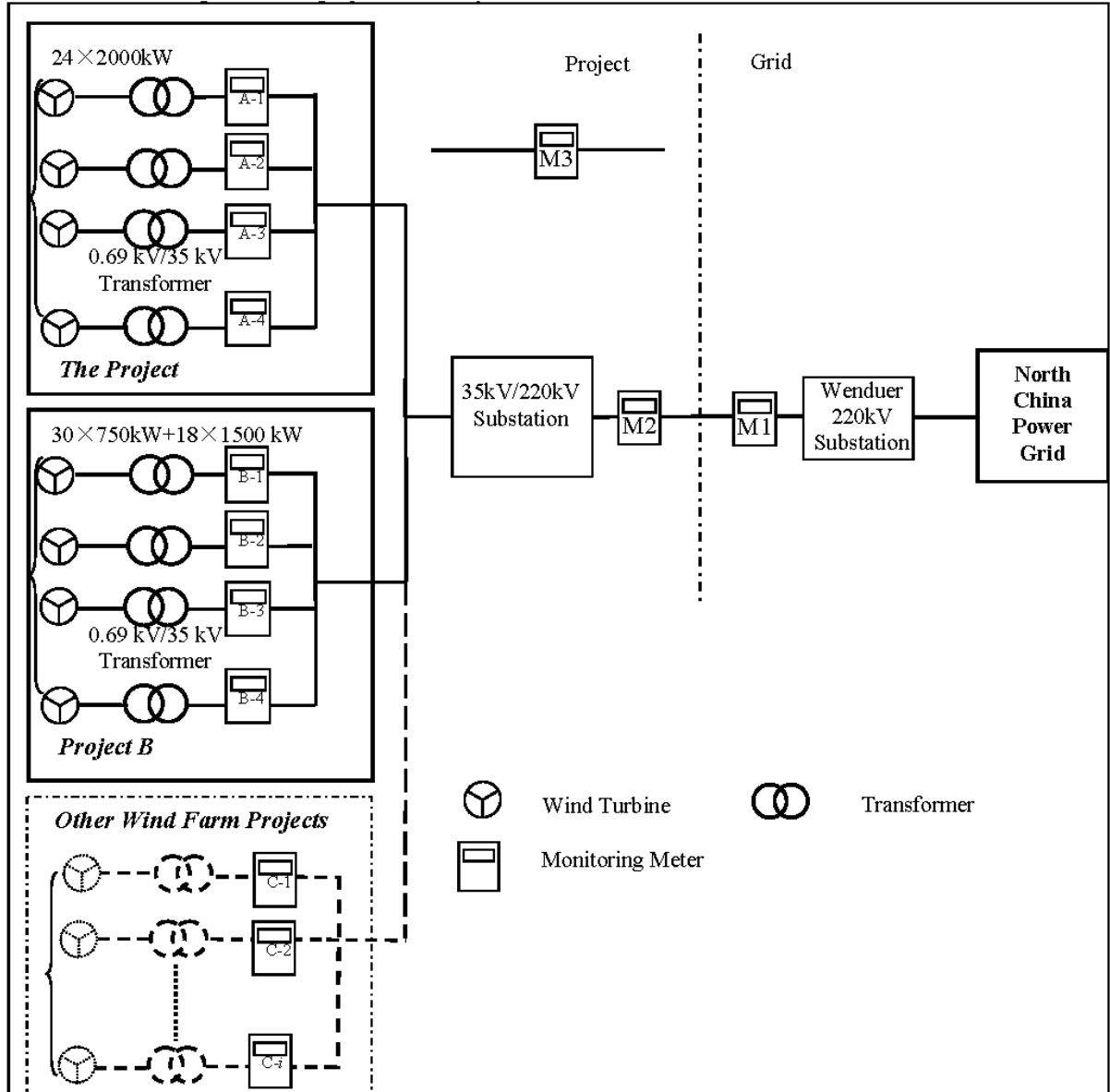

Figure 4: The location of meters

The Project shares the 35kV/220kV substation and gateway meters (M1 as the main meter and M2 as the backup meter) with Project B (Inner Mongolia Jingneng Saihan Wind Farm Phase I Project), and other project(s) which are under construction and will be connected to the 35kV/220kV substation. Before other project(s) (so called other project(s), of which Inner Mongolia Jingneng Saihan Wind Farm Phase III Project is in operation on 14/12/2012¹⁰, and other more projects will be planned for construction) puts into operation, monitoring equipment

¹⁰ Inner Mongolia Jingneng Saihan Wind Farm Phase III Project quality supervision and inspection reports

include M1, M2, M3, A-1, A-2, A-3, A-4, B-1, B-2, B-3 and B-4; After other project(s) puts into operation, C-1, C-2...C-i will be included in the monitoring equipment.

The main meter M1 is employed at the grid company substation and the grid company is responsible for conducting the monitoring. The backup meter M2 is equipped at the high voltage of the 35kV/220kV substation at the Project site and the project owner is responsible for conducting its monitoring. The accuracy of the meters M1 and M2 is 0.2s. At the same time, the data measured by M1 and M2 can be monitored and recorded at the on-site control centre using a computer system.

Additionally, a spare 10 kV line is used for supplying electricity to the Project, Project B and Other project(s) in emergencies. $EG_{im-spare,y}$ is measured by the meter M3 which is owned, operated and installed by local power distributor. Sales receipt will be cross-check with the meter reading. The accuracy of M3 is 2.0, which meets the national requirement. The calibration will be done in line with the national calibration standard.

The 24 sets of wind turbines of the Project were divided into 4 groups, and each group is connected with a 35kV transmission line and installed with a meter at the low voltage side of 35kV/220kV substation. These meters (A-1, A-2, A-3, A-4) are installed as the auxiliary meters to calculate the electricity supplied to the grid by Group A-i (i=1,2,3,4) of the Project. Similarly, Four meters (B-1, B-2, B-3, B-4) are installed as auxiliary meters to calculate the electricity supplied to the grid by Group B-i (i=1,2,3,4) of the Project B. The accuracy of these eight meters is 0.5s.

Moreover, considering there are other wind farm project(s) (so called other project(s), of which currently Inner Mongolia Jingneng Saihan Wind Farm Phase III Project is in operation, and other more projects will be planed for construction) , will share the 35kV/220kV substation on the Project site, the gateway meters (M1 and M2) in Wenduer 220kV substation and the M3 on a 10kV spare line, more meters (C-1, C-2,...C-i) will be installed on the 35kV transmission line at the other project(s) site to monitor the supplied electricity by other project(s). The accuracy of these meters (C-1, C-2...C-i) will be no lower than 0.5s and they will be calibrated in accordance with national standards.

In order to deal with the jointly-reading problem, the project owner and the grid company set up the procedure and calculation method to determine the net electricity supplied to the grid by the Project, which is calculated as follows:

$$EG_{facility,y} = \frac{EG_{A-i,y}}{EG_{A-i,y} + EG_{B-i,y} + EG_{C-i,y}} EG_{export,y} - EG_{import,y} - EG_{im-spare,y} \quad (1)$$

Where:

- $EG_{facility,y}$ = Quantity of net electricity generation supplied by the project to the Grid in year y
- $EG_{export,y}$ = Total electricity supplied to the grid via the main power line by the Project, Project B and other project(s) in the year y.
- $EG_{import,y}$ = Total electricity imported from the grid by the Project, Project B and other project(s) in year y.

$EG_{A-i,y}$	=	Total electricity imported from the grid by the Project, Project B and other project(s) in year y.
$EG_{B-i,y}$	=	Total electricity imported from the grid by the Project, Project B and other project(s) in year y.
$EG_{C-i,y}$	=	Quantity of electricity supplied to the grid by Group C-i (i=1,2...n) of other project(s) in year y.
$EG_{im-spare,y}$	=	Total electricity purchased from the grid by the Project, Project B and other project(s) through the spare 10 kV line in the year y.

4. Data Collection

Before other project(s) are connected to the 35kV/220kV substation at the Project site, the verification use the data of the main meter M1, the meter M3 installed on the spare 10 kV line and eight auxiliary meters on 35kV transmission line as long as the inaccuracy of these meters is within the permissible tolerance. The main procedures are as follows:

- 1) According to the requirements of power purchase/sales agreement, the project owner and the grid company should collect the data of both the main meter M1 and the backup meter M2 periodically, and check them at the same time.
- 2) For the electricity supplied to the grid by the project activity, the project owner collects and records the data of auxiliary meters and calculates the electricity supplied to the grid by the Project as per the procedure and calculation method jointly set up. Then the project owner provides sales receipt to the Grid Company. A copy of the sales receipt is stored for cross-check.
- 3) When the electricity generated by this project cannot meet the electricity requirement of the power plant, the grid company supplies the electricity to the project owner. The Grid Company provides an electricity sales receipt to the project owner and the sales receipt is stored by the project owner.
- 4) The project owner records the power supplied to and purchased from the grid as well as the electricity purchased from the spare 10 kV line, and hence calculate the net electricity supplied to the grid;
- 5) The project owner well keeps the records of the main meter, the meter installed on the spare 10 kV line and the eight auxiliary meters' data readings for verification by the DOE.

In any case that any of the eight auxiliary meters on 35kV transmission line exceeds the allowable tolerance or its malfunction occurs, the project owner will give up the emission reductions during the period when any of the eight auxiliary meters are inaccurate. Otherwise, if the fault of the main meter M1 exceeds the allowable tolerance or its malfunction occurs but the eight auxiliary meters are within the allowable tolerance, the grid-connected electricity generated by the Project will be resolved by following measures:

- 1) Adopting the backup meter M2, the meter M3 installed on the spare 10 kV line and the eight auxiliary meters' data, unless a test by either party reveals it is inaccuracy;

- 2) If the inaccuracy of the backup meter M2 is not within the acceptable limits or it cannot work properly, the project owner will give up the emission reductions during the period when both the main meter and the backup meter are inaccurate;

In addition, in any case that the fault of the meter M3 installed on the spare 10 kV line exceeds the allowable tolerance or its malfunction occurs, to be conservative, the project owner will apply the largest data over the years to calculate the emission reductions.

After the other project(s) connects to the shared 35kV/220kV substation at the Project site, the collection procedures of the data measured by the meter (C-1, C-2,...C-i) are similar to the above procedures of the Project and Projects B. If any meter (C-1, C-2,...C-i) exceeds the allowable tolerance or its malfunction occurs, the project owner will give up the emission reductions during the period when any of the meters (C-1, C-2,...C-i) are in malfunction.

5. Calibration of Meters & Metering

The metering equipment will be properly calibrated and checked annually for accuracy. The project owner will prepare backup procedures to deal with any errors occurred to the meters. The calibration records carried out by the grid company should be provided to the project owner, and these records will be maintained by the project owner and the third party designated.

Meters should be tested by a qualified metric organization co-authorized by the project owner and the grid company within 10 days after:

- 1) The detection of the reading difference between the main meter and the backup meter that exceeds the allowable tolerance.
- 2) The equipment's malfunction caused by improper operation

All the calibration test records should be maintained safely for the verification.

6. Data Management System

To keep safely the record of the data collected during monitoring, this project will set up a complete data management system. The project will perfect the whole monitoring procedure by developing the VCS manual, tracking information from the primary source to the end-data calculations in paper document format. It is the responsibility of the project owner to provide additional necessary data and information for validation and verification requirements of respective DOE. Physical documentation such as paper-based maps, diagrams and environmental assessment will be collated in a central place, together with this monitoring plan. All paper-based information will be stored by the project owner and kept at least one copy.

At the end of each month, the monitoring data will be filed in a spreadsheet, and the paper-based printout should be also archived. Furthermore, the project owner collects the sales receipts for the electricity supplied to the grid as a cross-check, and compiled the monitoring report including the monitoring data and relevant evidence at the end of each crediting year.

All the data will be kept for two years following the end of the last crediting period.

7. Monitoring Report

After the VCS project manager collects and sorts the monitored data, the monitoring report is prepared by the project developer. The project developer has to make sure that the format and content of the monitoring report are consistent with the monitoring methodology in the registered PD.

5 QUANTIFICATION OF GHG EMISSION REDUCTIONS AND REMOVALS

5.1 Baseline Emissions

According to the registered PDD, the baseline emissions are calculated as the electricity supplied by the project activity to the grid ($EG_{facility,y}$ in MWh) times the combined margin emission factor ($EF_{grid,CM,y}$ in tCO₂/MWh) as follows:

$$BE_y = EG_{facility,y} \times EF_{grid,CM,y} \quad (2)$$

Where:

BE_y	Baseline emissions in year y (tCO ₂ e)
$EG_{facility,y}$	Quantity of net electricity generation supplied by the project to the Grid in year y
$EF_{grid,CM,y}$	Combined margin CO ₂ emission factor for grid connected power generation in year y calculated using the latest version of the “Tool to calculate the emission factor for an electricity system” (tCO ₂ e/MWh)

Quantity of net electricity generation supplied by the project plant/unit to the grid in year y ($EG_{facility,y}$) in this monitoring period (27/10/2009-20/09/2015) as in the table below:

Table E-1 Quantity of net electricity generation to the Grid during the Monitoring Period

Period	EG _{export,y} (MWh)			EG _{import,y} (MWh)			EG _{im-spare,y} (MWh)			EG _{A-1,y} (MWh)	EG _{B-1,y} (MWh)	EG _{C-1,y} (MWh)	EG _{facility,y} (MWh)
	Invoice of electricity sales	Measured by the meter	Conservative value	Invoice of electricity sales	Measured by the meter	Conservative value	Invoice of electricity sales	Measured by the meter	Conservative value	Measured by the meter	Measured by the meter	Measured by the meter	
27/10/2009 - 31/12/2009	31,843.04	31,843.04	31,843.04	117.49	117.49	117.49	5.92	5.92	5.92	0.00	33,030.89	0.00	0.00
01/01/2010 - 31/12/2010	236,128.79	236,128.79	236,128.79	632.85	632.85	632.85	34.57	34.57	34.57	90,468.11	149,277.06	0.00	88,436.04
01/01/2011 - 08/06/2011	108,556.43	108,556.43	108,556.43	427.19	427.19	427.19	14.77	14.77	14.77	53,434.87	56,297.21	0.00	52,420.41
09/06/2011 - 20/05/2012	0.00	0.00	0.00	0.00	0.00	0.00	0.00	0.00	0.00	0.00	0.00	0.00	0.00
21/05/2012 - 31/12/2012	114,400.64	114,400.64	114,400.64	440.73	440.73	440.73	21.06	21.06	21.06	51,454.19	58,566.97	6,124.80	50,219.20
01/01/2013 - 31/12/2013	325,842.43	325,842.43	325,842.43	928.32	928.32	928.32	34.11	34.11	34.11	85,162.55	118,136.04	126,660.71	83,137.55
01/01/2014 - 31/12/2014	291,608.30	291,608.30	291,608.30	1,015.73	1,015.73	1,015.73	62.68	62.68	62.68	86,037.33	99,777.27	109,744.20	83,808.92
01/01/2015 - 20/09/2015	189,104.81	189,104.81	189,104.81	417.53	417.53	417.53	33.13	33.13	33.13	60,142.01	59,116.51	72,946.28	58,721.35
Total	1,297,484.44	1,297,484.44	1,297,484.44	3,979.84	3,979.84	3,979.84	206.25	206.25	206.25	426,699.05	574,201.96	315,476.00	416,743.47

Among which, $EF_{grid,CM,y}$ is 0.9502 tCO₂/MWh in the first crediting period, therefore, the Baseline Emission is:

$$BE_y = EG_{facility,y} * EF_{grid,CM,y} = 395,987 \text{ tCO}_2.$$

5.2 Project Emissions

According to ACM0002, no project emissions were to be counted by the Project.

Hence, $PE_y=0$.

5.3 Leakage

According to the ACM0002, no leakage emissions are considered.

5.4 Net GHG Emission Reductions and Removals

According to the Section 5.1, 5.2 and 5.3 above,

$$BE_y = 395,987 \text{ tCO}_2\text{e};$$

$$PE_y = 0 \text{ tCO}_2\text{e};$$

$$LE_y = 0 \text{ tCO}_2\text{e};$$

Therefore, $ER_y = BE_y - PE_y - LE_y = 395,987 \text{ tCO}_2\text{e}$

Since the electricity generated during the periods of 09/06/2011-20/05/2012 has been issued as CERs, the emissions during this period need to be excluded. After exclusion, this monitoring period started from 27/10/2009 to 20/09/2015, with totally 1,808 days. Based on the annual estimated emission reductions from the registered CDM PDD, the amount of emission reductions for this monitoring period would be $112,655 \text{ tCO}_2\text{e}/365\text{d} \times 1,808\text{d} = 558,028 \text{ tCO}_2\text{e}$. The actual emission reductions in this monitoring period (1,808 days) are 395,987 tCO₂e, which is 29.04% less than the estimation in the registered PDD.

Year	Baseline emissions or removals (tCO ₂ e)	Project emissions or removals (tCO ₂ e)	Leakage emissions (tCO ₂ e)	Net GHG emission reductions or removals (tCO ₂ e)

27/10/2009-31/12/2009 ¹¹	0	0	0	0
01/01/2010-31/12/2010	84,031	0	0	84,031
01/01/2011-08/06/2011	49,809	0	0	49,809
09/06/2011-20/05/2012	0	0	0	0
21/05/2012-31/12/2012	47,718	0	0	47,718
01/01/2013-31/12/2013	78,997	0	0	78,997
01/01/2014-31/12/2014	79,635	0	0	79,635
01/01/2015-20/09/2015	55,797	0	0	55,797
Total	395,987	0	0	395,987

¹¹ The project started operation since 27/10/2009, but due to the unstable operation of the project, the project was suspended for adjustment until it resumed operation in April of year 2010. Therefore, date in 2009 has been considered as zero. Then the emission reductions in 2009 are considered as zero which is most conservative.