



Sustainable Development Verified Impact Standard

INSTALLATION OF HIGH-EFFICIENCY WOOD- BURNING COOKSTOVES IN MALAWI – PROJECT 2



Document Prepared by C-Quest Capital LLC

1015 18th Street, NW Suite #730
Washington, DC 20036

Project Title	Installation of High-Efficiency Wood-Burning Cookstoves in Malawi – Project 2
Version	01
Date of Issue	22 June 2021
Project Location	Republic of Malawi
Project Proponent(s)	<u>C-Quest Capital Stoves Asia Limited</u> Ken Newcombe, knewcombe@cquestcapital.com 1 (240) 491-2650 Sarah Stever, sstever@cquestcapital.com 1 (415) 290-1144
Assessor Contact	Carbon Check
Project Lifetime	5 July 2020 to 5 July 2030, ten-year lifetime
History of SD VISTA Status	No previous attempts at SD VISTA certification made to date
Other Certification Programs	VERRA Verified Carbon Standard (2372)
Expected Future Assessment Schedule	Initial validation/verification anticipated in 2021

CONTENTS

- 1 SUMMARY OF SDG CONTRIBUTIONS 3**

- 2 PROJECT DESIGN..... 7**
 - 2.1 Project Objectives, Context and Long-term Viability7
 - 2.2 Stakeholder Engagement20
 - 2.3 Project Management29

- 3 BENEFITS FOR PEOPLE AND PROSPERITY 33**
 - 3.1 Condition of Stakeholders at Project Start33
 - 3.2 Expected Impacts on Stakeholders33
 - 3.3 Stakeholder Monitoring Plan35
 - 3.4 Net Positive Stakeholder Well-being Impacts37

- 4 BENEFITS FOR THE PLANET 39**
 - 4.1 Condition of Natural Capital and Ecosystem Services at Project Start39
 - 4.2 Expected Impacts on Natural Capital and Ecosystem Services40
 - 4.3 Natural Capital and Ecosystem Services Monitoring Plan41
 - 4.4 Net Positive Natural Capital and Ecosystem Services Impacts41

- APPENDIX 42**

1 SUMMARY OF SDG CONTRIBUTIONS

Row number	Estimated Project Contribution by the End of Project Lifetime	SDG Target	SDG Indicator	Net Impact on SDG Indicator	Section Reference	Claim, Asset or Label
1	Contribute to the eradication of extreme poverty (measured at less than \$1.25 per day) as the improved cookstove is a basic service necessary to lead a healthy and productive life, including saving time and money at the household level, and by the project contracting individuals, living at or near the poverty level (specific to Stove Champion positions) with salaries higher than \$1.25 a day	1.1	1.1.1 Proportion of population below the international poverty line, by sex, age, employment status, and geographical location (urban/rural).	Implement activities to decrease	3.2	SD VISta labeled VCUs
2	Contribute to improved nutrition status of household beneficiaries by providing direct access to an ICS that ensures reliable and efficient energy increasing household food safety and nutrition intake	2.1 2.2	2.1.1 prevalence of undernourishment. 2.2.2 Prevalence of malnutrition among children under 5 years of age, by type (wasting and overweight).	Implemented activities to increase	3.2	SD VISta labeled VCUs

3	Reduce the fine particulate matter (PM2.5) emitted during cooking thereby improving overall health outcomes and reducing burdens of disease	3.2, 3.9	3.2.1 Under-five mortality rate. 3.9.1 Mortality rate attributed to household and ambient air pollution.	Implemented activities to decrease	3.2	SD VISTA labeled VCUs
4	Contribute to education through the distribution of 20 scholarships to female students for four years, until the completion of secondary school, with additional scholarships anticipated during the project lifecycle	4.0	4.1.2 Completion rate (primary education, lower secondary education, upper secondary education).	Implement activities to increase	3.2	SD VISTA labeled VCUs
5	Contribute to community-level exposure and awareness of climate change, sustainable development, health, and nutrition well-being, through informal training on these topics and the improved cookstove	4	Goal 4: Ensure inclusive and equitable quality education and promote lifelong learning opportunities for all.	Increase	3.2	SD VISTA labeled VCUs
6	Reduce drudgery, specifically for women and children, as time saved through reduction of time spent collecting fuelwood and cooking time, monitored at an average of 1 hour/day default factor for rural	5.4	5.4.1 Proportion of time spent on unpaid domestic and care work, by sex, age, and location.	Decrease	3.2	SD VISTA labeled VCUs

	areas with open-fire baseline equivalent efficiency in Malawi ¹					
7	Increase access to clean cooking technology with TLCRS installations in approximately 1.1 million Malawian households under the project lifecycle	7.1 13.1	7.1.2 Proportion of population with primary reliance on clean fuels and technology 13.1 strengthen resilience and adaptive capacity to climate-related hazards and natural disasters.	Increase	3.2	SD VISta labeled VCUs
8	Contribute to paid positions through the Stove Champion Program (post-stove installation follow-up) and full-time positions by contracting on average 280 staff (varying lengths of time) with a focus on hiring females.	8.3 8.5	8.3.1 Proportion of informal employment in non-agriculture employment, by sex. 8.5.2 Unemployment rate, by sex, age, and persons with disabilities.	Increase	3.2	SD VISta labeled VCUs

¹ P.P. Krishnapriyal et al. (2021) *Do improved cookstoves save time and improve gender outcomes? Evidence from six developing countries*. Manuscript submitted for publication. CQC-TLC-RS studied by Berkeley Air Monitoring Group.

9	Contribute to the increase in resilient infrastructure and sustainable industrialization through the purchase of all manufactured metal parts for the project activity at Ener-G-Africa (EGA), a Malawian entity, formed by CQC	9.3	9.3.1 Proportion of small-scale industries in total industry value added.	Increase	3.2	SD VISta labeled VCUs
10	Contribute to the economic inclusion of women through a donation of .05 USD per stove to the Village and Savings Loan (VSL) program to provide monetary access to stove beneficiaries, to be initiated in August 2021	10.2 1.4	10.2 empower and promote the social, economic, and political inclusion of all. 1.4.1 proportion of population living in households with access to basic services (including financial services and microfinance).	Implemented activities to increase	3.2	SD VISta labeled VCUs
11	Contribute to emission reduction through an estimated reduction of 50 tCO ₂ e from the replacement of baseline stoves with TLCRS	13.0	13 Reduction in emissions as compared to baseline scenario (open fire)	Increase	VCS validation report	SD VISta labeled VCUs
12	Contribute an estimated reduction of deforestation of 3 tons of woody biomass from forests surrounding the communities and reducing pressure on forest reserves	15.1 15.3	15.1.1 Forest area as a proportion of total land area 15.3.1 Proportion of land that is degraded over total land area.	Implemented activities to increase (15.1) Implemented activities to decrease (15.3)	4.2	SD VISta labeled VCUs

2 PROJECT DESIGN

2.1 Project Objectives, Context and Long-term Viability

2.1.1 Summary of Project Sustainable Development Objective(s)

C-Quest Capital LLC and its affiliates and subsidiaries (CQC) Improved Cookstove (ICS) project – CQC-TLC Rocket Stove (TLCRS) – and the complimentary secondary projects will enable and enhance household level access to sustainable development objectives by sensitizing, distributing, installing, and maintaining fuel-efficient ICSs in Malawi. The project aligns with and will contribute to sustainable development objectives outlined in *Table 1: Summary of SDG Contributions*. Through the distribution and implementation of TLCRS stoves, this grouped project aims to reduce demand for wood fuel, slow local deforestation, reduce the drudgery of collecting wood fuel – hard and dangerous labor – performed by women and children at significant distances from villages, reduce time spent cooking over open fires inhaling toxic smoke, increase time spent on improving life status i.e., through economic endeavors, education, improve the health status through reduced exposure to household air pollutants (HAPs) and improve the nutrition status, through a myriad of ways including nutrient retention from decreased cook times and decreased food and water-borne illnesses.

The project is described in several thematic buckets that reflect the sustainable development objectives and impact. The thematic buckets and summary of objectives are as follows, listing goal to claim for SDG labels and further corresponding evidence in sub-bullet:

Economic Impact

The project will result in both short and long-term contracting. In the short term, teams of local men and women will be contracted and trained to make bricks and build stoves. Field staff, also known as “health promoters” (HPs) will carry out training work and arrange for stove construction materials. Some of the HPs will be trained to work as ‘enumerators’ and carry out stove registrations, captured through a mobile phone application that sends captured information to an online cloud database. Staff will be paid a monthly retainer and incentive performance-based payments per stove built and registered are also provided.

Long-term contracting (for at least a decade) will be available through the Stove Champion (SC) program which visit(s) post-wet season for each beneficiary household. The key objectives of the SC program are to address any communication deficiencies, reiterate stove benefits, and good stove use practices. These maintenance and informational visits will be performed to maximize the benefits of the ICS for women, children, infants, and the environment. SC will be paid on a monthly retainer and incentive performance payment per stove built and registered. SCs will also receive a bicycle (repair and upkeep costs covered by CQC) and phone data allowances. CQC aims to prioritize women for the SCs positions, due to the nature of the work and cultural relevance to the project mission.

This activity will contribute to SDG 1 and SDG 8 and will contribute to paid positions and economic well-being in the following ways:

- **GOAL 1:** Improved cookstove is a basic service necessary to lead a healthy and productive life, including saving time and money at the household level (1.1)²
 - Conduct train-the-trainer methodology increasing knowledge and training capacity of country national staff with sensitivity to traditional values (13.3, 17.16)
 - Retainer and performance payment for Health Promoters (HPs) will permit increased income to avoid seasonal poverty (2.0)
 - Contract on a seasonal or full-time basis, with average salaries higher than the international poverty line. (8.3, 8.5).
- **GOAL 8:** Reliable energy access enhances productivity and economic growth, CQC will contract staff long term with a focus on hiring female country nationals (8.3, 8.5)³

Health and Nutrition Impacts

The project has the potential to transform the way rural Malawi cooks by providing cleaner and safe kitchen environments, through the reduction of PM2.5, black, and brown emissions. UN Research⁴ concludes that ICSs ensure safe access to energy which is intrinsically linked to the goal of improving nutrition by reducing the cause of undernutrition by increasing the availability of and/or access to food of sufficient quality (dietary energy consumption) through reducing the need to trade food for fuel and quality (nutrient content) by reducing the cooking time increasing nutrient retention.

The projects will address SDG 2 and SDG 3 in the following ways:

- **GOAL 2:** Efficient improved cookstoves advance nutrition status, particularly for children under five years of age by reducing the burden of firewood collection, the time to prepare food, the need to buy firewood, or trade food for fuel which directly impacts nutrition status (2.1., 2.2)⁵
 - Increase use and access to sustainable agriculture technology through a project partnership with USAID to distribute 2,000 drip irrigation systems to households adopting the project activity (2.0, 1.1)
- **Goal 3:** Reduce fine particulate matter (PM2.5) emittance from the reduction of household air pollution due to use of the TLCRS, improving well-being for women and children (3.2, 3.9)⁶
 - Reduce severe burns to infants and children with the TLCRS's technology of a closed combustion chamber and stable base (3.2)

² Applies to paid opportunities of individuals who were absent from the formal sector and previously lived near, at, or below the international poverty level.

³ Applies to paid opportunities of individuals at full and productive levels with decent work for all, specifically in non-agriculture employment with equal pay for work of equal value across sexes – the ethos of SDG 8.

⁴ Bervoets, et al., (2017).

⁵ Clean Cooking Alliance (n.d.).

⁶ Amegah A. K. (2020).

- Improve air circulation through decreased household air pollution by increased construction of half-wall kitchens monitored by CQC Stove Champions (3.2, 3.4, 3.9)
- Reduce consumption of poorly prepared foods and increase abilities for more efficient water boiling for consumption (3.9)
- Increase maternal health, well-being, and nutrition status (+4,000) through project partner delivery with local area health clinic service area (2.1, 3.0, 5.0)

Clean and Sustainable Energy Impacts

The primary project activity will result in the dissemination of clean cooking technology to sectors of the Malawi population that are often excluded from development activities. Specifically, clean, and sustainable energy is made available for in-kind contributions.

The projects will contribute to SDG 7, SDG 9, and SDG 13 in the following ways:

- **Goal 7:** Clean cooking technology provides an essential tool to addressing energy poverty and ensuring sustainable energy security in approximately 1.1 million Malawian households during the project lifecycle (7.1, 13.1)
- **Goal 9:** Increase sustainable industrialization in Malawi by supporting the foundation of a manufacturer to produce metal parts needed for the project activity (9.3)
- **Goal 13:** Reduce carbon emissions by approximately 5 tCO₂e from the reduction in burning solid fuels for cooking and heating in the household, this does not include black and brown carbon (13.0)

Household and Women-Centric Impacts

Household and women-centric impacts focus on increased awareness of climate change through training, time saved with reduction of fuel collection and time it takes to prepare a meal, and microloan financing by CQC. By switching to fuel in small, twig-sized pieces of woody biomass, women, and girls save time collecting, cutting, and carrying heavy wood over long distances. As the CQC TLCRS burns at a hotter temperature, with less fuel used, due to combustion chamber and stove design, cooking the day's meal takes approximately an hour less than it would take to cook the same meal over the TSF. Research by Berkeley Air Monitoring Group⁷, showed two hours a day savings in switching to two stoves per household from the TSF and a meta-analysis of all research into time savings from ICS showed the on average time savings across sub-Saharan Africa to be about one hour per day.

The project activities will bring about multiple benefits (SDG, 4, 5, and 10) to women and girls in the following ways:

- **Goal 4:** Increase awareness of climate change's impacts on health, nutrition status, and well-being through community-level training with direct links to the project activity to promote adoption rates (4.3)

⁷ Berkeley Air Monitoring Group (2020).

- Increase vulnerable girls' access to higher education by providing 20 scholarships for four years, up to the completion of secondary school, with anticipated project continuance (4.0)
- Children, particularly girls, are frequently kept at home to support household chores, like cooking and collecting firewood, estimated on average to be 10 hours per week, with a TLCRS more time can be dedicated to education – attending school and studying⁸
- **Goal 5:** Reduce women and children's drudgery through times savings in reducing time spent cutting, collecting, and carrying firewood from trees far removed from households and reduce time spent cooking over toxic smoky open fires. These tasks, when gone undisturbed, are a major cause of gender inequality (5.4)⁹
- **Goal 10:** Increase savings and microfinance loan potential of Village and Savings Loan programs through a direct donation per stove kept in use by the project beneficiary (10.1, 1.4)

Climate Change Impacts

The communities in and around the project areas depend on the forest reserves of the Dzamalyama, Thuma, and Kuti. Since the forest is observed as a public place it is often used for the collection of fuelwoods, which significantly contributes to deforestation and degradation. The distribution of the TLCRS will reduce fuelwood consumption and improve watershed management. Due to TLCRSs popularity and widespread community use, there will be a reduction in firewood cutting from live trees resulting in better management of protected areas.

The project activities are proposed to contribute to SDG 13 and SDG 15, with SDG 13's benefits detailed above and SDG 15's explained as follows:

- **Goal 15:** Reduce deforestation and degradation by up to 3 tons in the project lifetime (15.1, 15.3)
 - Increase biomass supply near/in villages through the distribution of bamboo seedlings to promote sustainable production of renewable wood sources to be used in the project activity (15.2, 12.2)

2.1.2 Description of the Project Activity

CQC's ICS project, a low-emission climate-resilient project, was initiated in response to community and continental need to reduce greenhouse gas emissions (GHG) to combat the worsening climate crisis that largely impacts the most vulnerable populations that reside in sub-Saharan Africa. The focus of the project is on the rural and peri-urban poor that cook on open fires ('three-stone fires' (TSFs)). The project activity is designed to facilitate household-level improvements in cooking amenities and improved health and well-being for women, girls, and infant children with benefits to all members of the household.¹⁰

⁸ Clean Cooking Alliance (n.d.).

⁹ K.Das et al., (2019).

¹⁰ Mortimer, K., et al., (2017).

This grouped project, with the primary project activity being the installation of ICSs and secondary project impacts or activities as described below, will undertake the following activities:

1. **Improved Cookstoves.** The primary project activity is the distribution and installation of the TLC Rocket Stove (TLCRS), a high-efficiency, long-life metal and (made from local material) brick stove that transitions households away from traditional open fire cooking to cleaner, more efficient cooking solutions with renewable biomass fuels. The TLCRS is offered in exchange for in-kind contributions of materials and labor only, as the rural population's disposable cash is limited, and paid positions, where possible, are often informal and operates external to the cash economy.

CQC uses an innovative digital platform to track and manage the ICS project. Education and training of field staff is an important component of project implementation. Using smartphones, CQC and its implementing partners administer various surveys and questionnaires to track project objectives, beneficiary information, and to monitor and evaluate implementation performance.

2. **Paid Opportunities.** CQC provides both short and long-term contracted positions. In the short term, CQC pays teams of men and women in local communities to make bricks and build stoves following rigorous training. Field staff, also known as 'health promoters' train women and families and arrange construction. Many 'health promoters' become 'enumerators' and use mobile phones to register the stoves onto our project database. Staff is paid on a monthly retainer and incentive performance payment per stove built and registered.

Long-term positions (for at least a decade) are available through the Stove Champion (SC) program under which the most successful enumerators are selected and trained to service 500-1000 households and their female clients. SC's undertake a minimum of one annual visit post-wet season to each household receiving a stove and ensure repairs are made following storm damage and users follow best practices in stove management repair. The key objectives of the SC program are to address any communication deficiencies and reiterate stove benefits and good practice in stove use and maintenance and maximize the benefits of improved stove use and ventilation to women, children, and the environment. SCs are also paid on a monthly retainer and incentive performance payment per stove built and registered and receive a bicycle and phone data allowances.

3. **Bamboo Seedlings.** CQC has distributed 268,273 bamboo seedlings to households with the TLCRS primarily in the Central district, since 2019, and is in the process of following up with these households to check on stove condition and bamboo survival rate. This distribution will continue as a secondary project activity, as an incentive to use and maintain the stoves and to contribute to firewood supply at the household level. CQC plans to provide an additional bamboo seedling to households using their TLCRS every year the stove is maintained and in use. CQC plans to select the most competent women managers of bamboo to provide additional seedlings to enable them to become producers of bamboo firewood for sale.

The bamboo secondary project is amplified by education to households on the benefits of bamboo, training on best practices to plant bamboo, and encouragement to plant bamboo seedlings alongside vegetable gardens for increased nutrition benefits, reduction in time as vegetables and bamboo can be watered simultaneously, and can serve as live fencing to protect gardens from roaming animals.

4. **Training.** While training trainers, CQC provides a one-day course on climate change and combustion theory, including impacts of household pollution on health and well-being, as an introductory background to the efficient cookstove intervention. CQC plans to implement training programs that include programs on establishing backyard gardens using drip irrigation kits and bamboo horticulture. Training will generate positive impacts to community groups by enabling community members to build alternative skills and build capacity. Through this training, CQC hopes to provide women the tools and knowledge necessary to become successful entrepreneurs, generate additional household revenue through the sale of produce and bamboo wood. These interventions are expected to advance socio-economic status,

generate greater community capacity for sustainable livelihoods, and increase climate resilience. The project aims to increase access to all village members but especially to women and other underrepresented groups, which have historically had little access to educational opportunities and employment.

5. **Village Savings and Loans.** The Village and Savings Loans (VSL) is a self-managed group at the village level meeting regularly to access and manage their basic financial services. Group members pool their savings to have a source of lending funds: members make savings contributions to the pool and can also borrow from it. The VSL is under the Group Village Headperson (GVH). Through the Stove Champions (SC) program each household that received a stove is visited within months of installation and on an ongoing basis thereafter at least once but preferably twice a year. Each recorded stove will result in a \$.05 contribution from C-Quest Capital to support community well-being through the VSL program. This monetary contribution is available to stove beneficiaries through a loan application. CQC will pilot this program in a selected Traditional Authority (TA) with plans to expand to the remaining TAs that serve as implementation areas.
6. **Women's Health.** The benefits to women's and children's health are multiple. Below are five that have been identified as indirect or direct benefits from the designed projects, primary and secondary.
 1. Many women in Malawi live far away from the closest healthcare facility. Pregnant women are encouraged to stay at the 'maternal waiting room,' a facility on the hospital/health center premises, a few weeks before their delivery date to ensure they can access healthcare services during the birth of their child. The Area 25 Health Clinic in Lilongwe typically supports 7,000 women throughout the length of their pregnancies. A permaculture garden system surrounds the clinic and is used to educate the women on proper nutrition and gardening techniques. Upon discharge will CQC fund 2-3 seedlings per patient and guardian (bamboo, high-value high yield fruit tree) in the 2021 year. CQC will also begin a double stove household pilot in 2,000 households equaling 4,000 households with plans to expand to all pregnant women receiving care at the Area 25 clinic.
 2. Significant reduction and potential elimination of the need to collect, cut, and carry heavy wood with improved health outcomes arising from the reduction in hard and risky labor of cutting, collecting, and carrying large bundles of firewood on their heads, often inflicting spinal, nerve, and muscle tissue injuries, for long distances outside their communities to their house, reducing the risk of physical abuse or accidents.
 3. Opportunities to improve nutrition status result through the reduced level of effort expended in fuel collection and ready access to cooking fuels to cook several meals a day and improve the digestibility of staple foods and reduction of food-borne illnesses through adequate cooking.¹¹
 4. Reduction of exposure to high PM2.5 and high CO biomass smoke due to higher efficiency of combustion leading to faster cooking and more complete combustion.
 5. Reduction in burn risk, significant to children and toddlers due to enclosure of the fire in the combustion chamber surrounded by thick bricks.
7. **Education Grants.** CQC will implement a Girls Education grant that provides funding to vulnerable girls to assist them with school fees, basic textbook needs, and uniforms. From the initiation of the project, 20 annual scholarships will be provided to girls for each of their four years in secondary school. Additional scholarships will be considered on an annual basis.
8. **Domestic Manufacturing Market Development.** Ener-G-Africa (EGA), a Malawian entity formed by CQC (as a minority shareholder) and Malawian entrepreneurs, manufactures all metal stove parts for CQC's rural

¹¹ FAO, (2017).

Sub-Saharan Africa TLCRS program. Since EGA started manufacturing metal parts for these stoves in January 2020, they have produced more than 300,000 sets of parts. CQC's orders for parts for SSA made in Malawi are for 7 million stoves over 2021-2024. These parts will be manufactured in Malawi, and a large portion will be exported to CQC's other countries of implementation, generating significant revenues for the Malawi entity and its employees.

EGA is a modern manufacturer in the heart of Lilongwe City. Currently, machines include 6 x eccentric presses, ranging from 25 tons to 90 tons with custom-designed dies; CNC automated ring-roller; Servo-Feeder; Automated and Manual decoilers; Auto-feed corrugation machine; Butt Welding Machine; 3 x MIG welders; 8 arc welders and a Surface grinder. EGA's sophisticated production line can produce 6,000 sets of parts in an eight-hour shift, with the capability to operate a 24-hour workload.¹²

EGA is expanding the workforce of skilled labor in Malawi. EGA provides knowledge and skills transfer with the introduction of new technologies, training in advanced manufacturing skills, and good wages and healthcare benefits. In addition, they are currently undergoing ISO 9001 certification for 2021.

9. **Time Savings.** By fuel switching to small, twig sizes pieces of fuelwood, women, and girls save time collecting, cutting, and carrying heavy wood over long distances. Because CQC TLCRS burns at a hotter temperature resulting in a faster cook time, cooking the day's meals takes about a house less than it would take to cook the same meal over the traditional three-stone open fire. Research CQC funded in Zambia showed two hours a day savings in switching to two stoves per household from open fires and a meta-analysis of all research into time savings from improved cookstoves showed the average time saving across sub-Saharan Africa to be about one hour per day.
10. **Forest Reserves.** The communities in and around the project areas CQC works depend on the forest reserves of Dzamalyama, Thuma, and Kuti. Since the forest is observed as a public place it is often used for the collection of fuelwoods and contributes to deforestation and degradation. We will also begin distributing TLCRS in the Neno district to reduce fuelwood consumption and improve the watershed. Through the use of the TLCRS, there is reduced firewood cutting from live trees and fathering of firewood inside watersheds and protected areas. In 2021, CQC will emphasize cookstove installation in communities bordering Malawi's major game parks managed as concessions by Africa Parks. These include Liwonde, Mangochi, and Nkhoswe.
11. **Drip Irrigation Kits.** CQC in partnership with USAID will distribute 2,000 drip irrigation kits to individual households within the next three months. The use of drip kits will enable vegetable production during the dry season, improving the availability of nutritious food and providing a revenue opportunity through the sale of fresh food for greater community-level access.

The secondary projects of CQCs work in Malawi as detailed above, with the primary project being TLCRS implementation, contribute to the overall SDG benefits of this grouped project. The project design cycle for the TLCRS is illustrated in image 1.

¹² Ener-G-Africa TLC Rocket Stove Mini Documentary in combination with C-Quest Capital: <https://www.youtube.com/watch?v=0oDBDytJPT0>

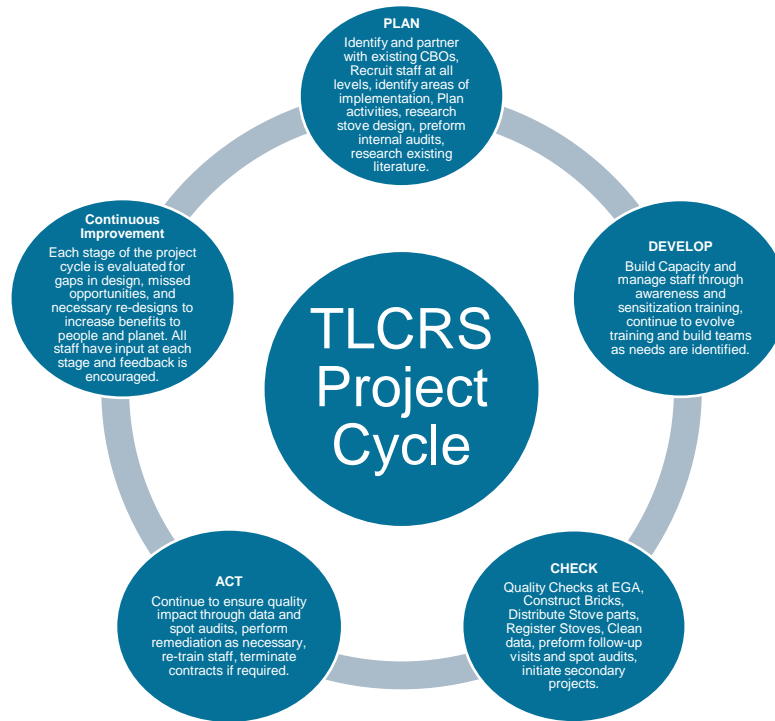

Image 1: TLCRS Project Cycle

2.1.3 Implementation Schedule

Date	Milestone(s) in the Project's Development and Implementation
2017	Implementation Begins: CQC Direct installs its first stove
July 2020	CQC applies for VERRA VCS for Malawi Projects
June 2021	CQC applies for Verra's Sustainable Development Verified Impact Standard (SD VISTA) SDG labeling.
July 2020	Project Start date: Project Activities commence with a new series of TLCRS installations and conducts initial Local Stakeholder consultations (continuous throughout project lifecycle).
September 2020	Implementation of a digital survey, with the transition to a new platform in June 2021
May – October 2021	Studies by University partners underway: Duke University, Oregon State University; Lilongwe University of Agriculture and Natural Resources, Emory University and University of California, Davis
June 2021 – December 2030	Concurrent monitoring and evaluation: spot audits conducted by independent auditors
August 2021	Contributions to Village Savings Loan begin and Education Grants initiated

July 2030	The 10-year project validation period concludes with a projected 1 million additional stoves installed. CQC applies for VVB renewal
-----------	---

2.1.4 Project Proponent

Organization Name	C-Quest Capital Stoves Asia Limited
Role in the Project	Project Proponent
Contact Person	Ken Newcombe
Title	Director
Address	Brumby Centre, Lot 42, Jalan Muhibbah, 87000 Labuan, Malaysia
Telephone	1 (240) 491-2650 +6 087 42828
Email	Cqc-operations@cquestcapital.com

2.1.5 Other Entities Involved in the Project

No other entity is involved with the CQC TLCRS Project.

2.1.6 Project Type

This is a non-AFOLU (agriculture, forestry, and other land use) grouped project with general sector contributions identified in the chart below, primarily energy efficiency.

Sustainable Development Verified Impact Standard Sectoral Scopes	U.N. Sustainable Development Goals
Sectoral Scope 2 - Climate Change Adaptation	Climate Action 13.1, 13.3, 13.B
	Life on Land 15.1, 15.2, 15.3
Sectoral Scope 3 - Education	Quality Education (primary & secondary) 4.1
	Vocational Training for All 4.3

Sectoral Scope 4 - Energy	Affordable energy 7.1
	Responsible Consumption and Production 12.2
Sectoral Scope 5 - Food	Zero Hunger and elimination of malnutrition 2.1, 2.2, 2.4
Sectoral Scope 7 - Health	Good Health and Wellbeing 3.2, 3.4, 3.9
Sectoral Scope 10 - Livelihoods	End Poverty in all its forms everywhere 1.1, 1.2, 1.4
	Decent Work and Economic Growth 8.3
	Reduced Inequalities 10.1
	Resilient Infrastructure, Promote Inclusive, and Sustainable Industrialization 9.3

2.1.7 Project Location

The ICS project and secondary project locations will take place in the geographic boundaries of the Republic of Malawi with geographic coordinates 13° 15'15.5" S latitude and 34° 18.091' E longitude.¹³



¹³ [Malawi Geographic coordinates - Latitude & longitude \(geodatos.net\)](http://geodatos.net)

2.1.8 Baseline Scenario

Before project initiation, households, almost exclusively apart from urban high-income households, in Malawi use traditional three-stove fires common to much of sub-Saharan Africa. The open fire (TSF) used by the target population requires large diameter logs, commonly procured from nearby non-renewable live biomass sources (firewood) found on forest patches or growing on/near farmland, necessary for managing an open 'three-stone fire.' As population growth and density have increased, demand for large diameter wood for three-stone open fires has led to intensified deforestation and land degradation and an increasing amount of time spent by women and girls, collecting firewood further and further away from their village communities.

Malawi is a land-locked country in southern Africa where the main economy is small-scale, rainfed subsistent traditional agriculture practices.¹⁴ Over 85% of the population of Malawi is involved in smallholder farming, with women representing over 80% of this labor force.¹⁵ With 83% of Malawians living in rural areas¹⁶ and 91% relying on firewood for cooking.¹⁷ The households that rely on firewood cook primarily on smoky inefficient three-stone fires using large-diameter branches and/or wood logs collected through unsustainable non-renewable processes from trees existing on surrounding farmland and forests.

2.1.9 Causal Chain(s)

See appendix A for the Causal Chain image.

2.1.10 Threats to the Project

Human-Induced Threats

Threat: Stove users' upkeep of stove falters resulting in either malfunctioning of the stove as designed or lack of stove use.

Solution: CQC conducts routine spot audits early in the process of construction of stoves in each main geographic focus for mass stove installation to detect stove construction, maintenance, and sub-optimal stove use. CQC requires its IPs to hire, train, and supervise stove builders and users, including Stove Champions, to visit each household to inspect their stoves, up to 2 times per year. This dramatically reduces the threat listed above. Additionally, CQC contracts independent third-party auditors or local CQC staff to perform spot checks or sample size reviews to identify lapses in stove upkeep. Upon receiving these reports CQC contracts sub-proponents, called Stove Champions, to perform follow-up visits to households to provide additional education and encourage stove upkeep and use.

¹⁴ Parrish et al., (2020).

¹⁵ Hyder and Behrman, (2014).

¹⁶ World Bank, Rural Population (% of total population) – Malawi: <https://data.worldbank.org/indicator/SP.RUR.TOTL.ZS?locations=MW>

¹⁷ World Health Organization data from 2019, updated June 07, 2021 states that 1.9% of the population of Malawi rely primarily on clean fuels and technologies for cooking: <https://www.who.int/data/gho/data/themes/air-pollution/household-air-pollution>

Where metal parts of ICS's commonly found on the market are made of low-grade steel, CQC has upgraded the metal parts for the TLCRS are made of higher-grade heat resistant steels, determined by extensive stress testing by Colorado State University, USA, to have a lifespan of a minimum of 10 years. Metal parts include a fuel shelf that doubles as a brick mould, pot skirt, and stovetop.

Threat: Failure of Behavior Change resulting in high levels of non-adoption

Solution: CQC continuously researches the impacts of behavior change for successful adoption. Study outcomes, whether formal or informal, are included in future training and community sensitizations to continue to positively, shape knowledge, enhance positive peer-to-peer influence, and increase women's sense of empowerment feeding into social cognitive theory on identity and self-belief. Non-adopters and non-implementors are specifically engaged to understand the barriers to success, these outcomes and conclusions are included in future training and disinformation is countered through community sensitization.

Threat: Carbon-financed stove distribution is not shown to have an increased impact on household uptake.

Solution: While research suggests that providing a subsidized ICS to the household does not have a positive impact on successful adoption, research does show that knowledge of times saving and awareness of the correlation between health benefits and reduced smoke improves adoption rates. Although CQCs ICS provided to households is subsidized, training highlights time savings and increase health benefits (decreases in acute respiratory illness for mothers and children, decreased morbidity/mortality from HAP, and increased nutrition status through retention of nutrients due to decreased cook times), as well as previous users reasons for adoption (cleanliness of pots, increased social standing, appearance, safety, less smoke). Awareness of the later impacts of ICS cooking is used to counter the threat.

Nature-Induced Threats

Threat: Climate Crisis induced displacement/migration (shock-related drought or flood) causing households to change location

Solution: Although the ICS are semi-stationary, with the energy-saving technology constructed encased in bricks made of commonly found local elements (5L each of clay, sand, dung, and water) which are the local in-kind contributions, the bricks can be deconstructed/demolished to remove the energy-saving steel technology. This technology can travel easily with the household in their migration and rebuild encasing the technology using the 5L mixture and brick shell provided to the household on initial implementation.

Threat: Continued deforestation and degradation making firewood an untenable source of biomass.

Solution: Although increased scarcity would support the use of the TLCRS, there is the potential that as the population continues to expand, particularly on the African Continent, there may be a point when firewood becomes an untenable source. Although access to modern fuels may not be physically or financially accessible to ICS households in the future, creating more dependence on biomass cooking. CQC trains on the use of small-diameter woody biomass, i.e., small branches and twigs harvested by non-destructive pollarding or coppicing, and use of woody crop residues such as maize cobs and provides households with bamboo seedlings for a fast-growth close-to-home source of regenerative biomass. Where possible, CQC will advocate for policy changes and the inclusion of regenerative forestry in

governments' low-carbon action plans to support forest protection and regenerative woodlots for sustainable consumption.

2.1.11 Benefit Permanence

To ensure the ICS project's long-term viability and the permanence of ICS and other program benefits, CQC has committed to the following long-term aims:

- (1) A steel manufacturer was founded and opened in Malawi where the three steel parts of each stove are built, this will continue throughout the project lifecycle. The local stove production will benefit the local economy as EGA offers job opportunities to Malawians, which continues to build the knowledge and skills for long-term inclusion in the formal sector of the national economy.
- (2) A 'per-household stove used' contribution to the Village and Savings Loans that works to increase the microfinance capital available to community groups to support increased economic projects and income-generating activities. CQC is intrigued to learn where this capital will be used and for what endeavors. CQC intends to understand the impact of these VSL contributions and if significant, increase the contributions to the VSL for long-term improvement and support of financial literacy and microfinance activities.
- (3) Implementation and Compliance (spot audit) teams will be hired and provided with forms of transportation and smart mobile phones that meet the physical mobility and remote connection requirements of the positions. Transportation provided includes bicycles, motorbikes, or motor vehicles, depending on the position. For Stove Champions and Health Promoters that may work on a seasonal or part-time basis, bicycles remain with staff members, contributing to year-round physical mobility that reduces time spent traveling by foot, increases access to local markets to sell income-generating products, and provides reliable access to local health facilities; overall, acting as a catalyst for upward economic well-being. This is a long-term commitment.
- (4) CQC is working to make the TLCRS available to all households through the purchase of CQC's 'Stove-in-a-box' kits. This provides the metal components of the ICS and directions on assembling the brick structure that houses the metal components. This 'Stove-in-a-box' program does not replace the projects outlined in section 2.1.2, rather it offers the stove to a sector of society that is not the target beneficiaries of the project – maintaining long-term benefits to Malawi. EGA with CQC's support plans to set up a distribution program for 'Stove-in-a-box' throughout Malawi, increasing availability along with other basic goods to rural families.
- (5) Through CQC training of stove champions, health promoters, communities, and continued individualized education support and training directly to households, CQC provides holistic, long-term environmental, health, nutrition-sensitive awareness, and community resiliency awareness to advance the benefits to stakeholders and maintain project activities and intended outcomes.

Moreover, CQC plans to continue activities until potential beneficiaries have been exhausted and remain committed to the continued improvement of rural livelihoods.

2.2 Stakeholder Engagement

2.2.1 Stakeholder Identification

CQC is constantly working to identify and engage stakeholders to expand information, seek input, and consult on impacts of project activities to local communities and individuals with parties that are directly and indirectly impacted, including those that show interest in the project activities but may not be materially affected by the activities.

CQC identifies and encourages involvement from stakeholders at all levels of society, from individuals, groups, communities that fall into one of two categories (a) are affected or likely to be affected by project activities and (b) may have an interest, either currently or in the future, in the project activities.

Stakeholders who marginally suit the scope of the project activities are still welcome to provide feedback to enhance the project impact.

Stakeholders were identified within each of the following categories: government, international government agencies, non-governmental organizations, religious aid agencies, academic, current, and potential future implementing partners, stove manufactures, carbon sector organizations, partner donors, the media, and individuals, and their families. Specific focus is made to include individuals and groups who may be directly or indirectly adversely affected by project activities.

Stakeholder engagement is a continuous process for CQC, which is demonstrated by paid opportunities of local individuals who contain the knowledge necessary to understand the landscape and culture of Malawi to support positive impacts and identify and mitigate adverse impacts for all stakeholders.

2.2.2 Stakeholder Description

Directly Affected Parties

(1) Current Beneficiaries: TLCRS registered users and other family members within the serviced households

Beneficiaries are identified as an individual, primarily women as the cook in the household, that is willing to adopt a climate transformation technology, i.e., the TLCRS. Beneficiary families are those living in or sharing the same family compound as project beneficiaries. No hierarchy of priority is established to determine who receives an ICS sooner rather than later. Each household demonstrates interest and provides in-kind contributions to build the stove exterior. There is occasionally a delay between an individual and the household that vocalized the desire to have a stove and the stove implementation due to availability of metal parts and implementing partner workloads, however, CQC provides an ICS to each household in Malawi that expresses the desire to adopt the technology. Beneficiaries that adopt the TLCRS are eligible to benefit from the secondary projects and benefit from the SDGs identified in chart 1.

(6) Potential Beneficiaries: new users and potential adopters

CQC actively seeks out new beneficiaries, through sensitization events, active communication with traditional authority leadership and influential authorities and traditional leaders, and promoting the TLCRS at local community gatherings, i.e., markets and health clinics. CQC seeks out partnerships to expand the climate transformation technology to those that use the three-stone open fire and are particularly vulnerable populations. An example of such a partnership is the relationship with Area 25 Health Center where CQC provides the TLCRS to pregnant women supporting their health and nutrition

status from early stages in pregnancy with the intent to have a multiplying effect on their infant children and other young children in the household.

The current and potential beneficiaries typically share similar characteristics within Malawi as our current target demographics are individuals and households in rural settings, although there are plans to expand into the peri-urban and urban settings to offer the TLCRS to any individual prepared to adopt its technologies. This plan is designed to drastically reduce the need to use the three-stone cookfire. CQC provides all households with a double stove, which consists of two sets of metal parts and two individual brick constructions attached with two bricks at floor level (image 2) to eliminate the use of the three-stone cookfire for cooking use.

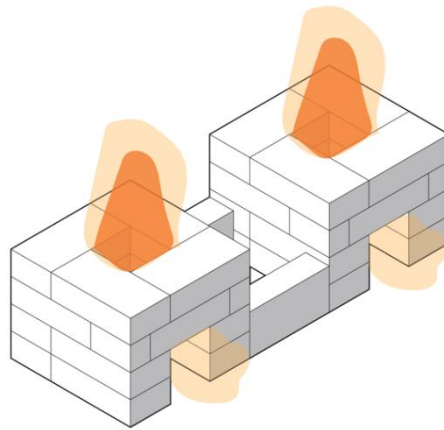

Image 2: TLCRS double stove brick design

Indirectly Affected Parties

- (1) Governmental Authorities: CQC engages with local traditional authorities through ‘Courtesy Calls’ to provide information and gain input on the anticipated projects under the TA local, CQC teams gain explicit permission to operate in these areas through the ‘Courtesy Calls;’
- (2) Environment, Health, and Nutrition public-sector agencies: In-country agencies that work in tandem with CQC’s projects through implementation, operate in the same geographical areas, or operate their projects that may touch upon similar sectors as the projects CQC implements;
- (3) Academic Institutions: CQC is invested in partnerships, providing funds, and welcoming interested academic institutions to study our projects at any level but particular interest to us is through direct household-level studies of beneficiaries so that CQC can best understand the impacts, positive and negative, how to magnify the positive and eliminate or reduce the negative impacts. CQC currently has relationships with academic partners at Duke University, Lilongwe University, and Oregon State University, and various contracts through other high-ranking academic institutions;

- (4) Local and International NGOs: In-country partners that work in tandem with CQC's projects through implementation, operate in the same geographical areas, or operate their projects that may touch upon similar sectors as the projects CQC implements;
- (5) Media: Any national media or international media that is interested in our projects;
- (6) Project Investors: CQC works with numerous organizations and/or companies whose financial support goes directly to cover the cost, operations, implementation, and transportation, among other costs, of CQC projects, which allows CQC to provide the TLCRS and other projects at no cost to the beneficiaries and receive economic support through village savings loans contributions made by CQC and numerous other projects including transportation equipment (bikes, motorbikes, trucks) and cellular phones to contract staff and education scholarships; and,
- (7) Others, as applicable and interested: CQC welcomes feedback and interest in our projects from interested sources that may not have been identified in this description. However, CQC reserved the right to act upon feedback and correspond with the party providing feedback to ensure it originates from a constructive source.

2.2.3 Stakeholder Consultation

CQC is committed to continuing consultations with stakeholders to ensure project activities include the identified benefits as they correspond to the Sustainable Development Goals. CQC underwent a local stakeholder consultation (LSC) on its parallel VERRA/Voluntary Carbon Standard (VCS) process as it seeks to obtain Voluntary Carbon Units (VCUs) from 26 October to 25 November 2020, CQC will re-engage the stakeholders that participated in the feedback for VCS/VCUs and seek new stakeholders that may have not been included, with a focus on underrepresented, women, and marginalized populations, due to the non-grouped nature of the VCS. The LCS for the SD Vista process will be executed like that of the VCS process, with additional requirements of the SD Vista continuous engagement of stakeholders.

For the VCS/VCU, the LSC sought feedback virtually, due to the ongoing Covid-19 pandemic, through feedback forms on CQC's website, direct email, and phone calls, with in-person distanced meetings occurring with individuals and groups of current beneficiaries. A newspaper advertisement was placed in THE NATION, Malawi's leading daily newspaper, announcing the LSC. The following chart provides information on how CQC will conduct stakeholder consultations for the SD Vista application.

Stakeholder Group	Identified Stakeholder (continuously expanding)	Consultation Activities
Directly Affected Parties	Current Beneficiaries (individual, household, and community level)	-Community Level Sensitization Activities -Open Communication with implementing partner and CQC Direct -Household Stove Champion Visits/ Surveys <i>-Methods may vary to provide consultations that mean the needs of the community/household.</i>

	Potential Beneficiaries and Community Groups (individual, household, and community level)	<ul style="list-style-type: none"> -Community Level Sensitization Activities -Open Communication with implementing partner and CQC Direct -Household Stove Champion Visits/ Surveys -Methods may vary to provide consultations that mean the needs of the community/household.
	Implementing Partners	<ul style="list-style-type: none"> -Open Communication with CQC -Training on Impacts of TLCRS and secondary project activities -Pre- and Post-training surveys
Indirectly Affected Parties	Governmental Authorities, Environment, Health and Nutrition public-sector agencies, Academic Institutions, Local and International NGOs, Media, Project Investors, and Others as applicable	<ul style="list-style-type: none"> -Published announcement of continuous stakeholder feedback – local newspapers, CQC website, and other media as appropriate. -Online, Email and Phone Distanced Feedback options -Annual Survey -Annual Reports published on CQC’s website -CQC’s Social Media Communication and Updates -Research Collaboration (academic, others (as applicable))

CQC Implementing Partners engage with beneficiaries and their families several times over the year through household visits. During these visits, education and maintenance are consistently reinforced to the household, with hands-on technical assistance, if necessary, by the Stove Champions. During the initial community sensitization and training by Implementing Partners, the benefits of the primary project and secondary projects are detailed to community members. Educational materials (brochures) are distributed to potential beneficiaries.

During the CQC Verra VCU LSC, Indirectly Affected Parties were approached virtually (email, phone calls, website collection forms) and Affected Parties were approached in-person. CQC has retained the stakeholder lists as well as the feedback sent during the VCU LSC. For SD VISta CQC will reapproach all identified stakeholders as well as expanding impacted stakeholders to match the defining parameter for SD VISta. Virtual LSC will initially occur during a 30-day window where identified stakeholders will be contacted through virtual means, informed about the SD Vista registry and the identified sustainable development initiatives and detailed included in this project description, and feedback will be collected and evaluated to determine if project designs should be altered to magnify positive impacts. Stakeholders will also be encouraged to provide public comment during the VERRA public comment period. To maintain continuous stakeholder communication, CQC will make a feedback section on our website permanent and seek feedback on an annual basis but feedback can be provided at any point over a year.

For Directly Affected Parties, CQC will include the collection of feedback on the Stove Champion or Spot Audit survey. Beneficiary LSC was conducted for the Verra VCU asset project and the following information was collected that corresponds with the SD Vista application and identified benefits to people and the planet:

Female beneficiaries of the project greatly appreciated the lack of smoke on the CQC stove compared to open fires and the stove has increased their time for other social/economic activities by allowing them to cook with fewer sticks. They also indicated that the pot skirt helps keep their pot cleaner and retain heat, thus allowing fast cooking. In conclusion, participants widely recognized the benefits of the stove programs already active in Malawi and look forward to seeing how the reach and impact will be expanded on and how the lives of the people living there will be changed in the years ahead.

A downside was mentioned by the female beneficiaries that initial cooking takes a bit longer, mostly when using a bigger pot as many households have bigger families. As such, CQC has added a second stove to support the elimination of the TSF and continues to decrease the amount of time it takes to cook as most meals are prepared in two pots. This is one example of how CQC is committed to project evolution through stakeholder comments.

Local stakeholder involvement will be continuous and evolutions or adaptations to the project will occur to amplify the benefits of the projects to the planet and people.

2.2.4 Continued Consultation and Adaptive Management

Consultation and Adaptive Management will continue throughout the project lifetime as CQC is committed to project evolution to best meet the needs of the beneficiaries and amplify, where possible, the impact of the project activities as they related to the SDGs. CQC is also committed to additional projects, where feasible, that multiply sustainable development and enhance the empowerment of women, child and household nutrition, health, and economic wellbeing.

CQC collects input from beneficiaries through touchpoints over a year, up to 5 times (see section 3.3 for more details). Interactions range from informal consultation discussions to more formal surveys with specific questions on use and adoption. Some of the visits are conducted by stove champions that inquire about likes, dislikes, adoption rates, benefits that CQC may not have identified, and unidentified challenges for the cook. Other visits are conducted as audits through CQC's compliance teams in-country or CQC operation staff.

Since the origination of the TLCRS, CQC has adapted the TLCRS as follows:

- Beneficiaries showed evidence of using the three-stone cookfire in addition to the TLCRS, which was identified through CQC audits and follow-up visits, as such, CQC added a second stove to each household with the intent to further reduce the use of a three-stone cookfire. The second stove allows the cook to cook both traditional sauces and grains simultaneously, further reducing the length of time it takes to cook the meals and increasing the time saved. Additional benefits can be seen in increased nutrition retention and health benefits through reduced PM2.5 and burn risk for children and infants in the kitchen.

- Academic research has shown that beneficiary' and potential beneficiary' knowledge of climate change and the reduction of emissions using an ICS does not equate to increased adoption rates. The relationship between climate change and greenhouse gas reductions through the TLCRS will continue as part of the sensitization and community-based training, however, additional topics on the benefits of TLCRS's use to the health and nutrition status of the household members will be included in the training, as research demonstrates there is a stronger association to these two topics and increased adoption rates.

CQC encourages continuous improvements through input from stakeholders, specifically the academy, beneficiaries, and potential beneficiaries. CQC seeks continued consultation and practices adaptive management to provide the best products and sustainable development outcomes to our beneficiaries.

2.2.5 Anti-Discrimination

CQC is committed to providing the best possible climate for maximum development and goal achievement for all its employees and contractors. CQC believes that discrimination in all its forms (gender, race, religion, sexual orientation, or other habits) and sexual harassment and assault have no place within the development sector and more specifically at CQC, our implementing partners, our employees, contractors, and third-party individuals, and within the projects we design, fund, and execute. Specifically, our project activities are designed to reduce or eliminate, where culturally possible, discrimination, sexual harassment, and sexual assault where it exists within the societies where we work.

CQC supports diversity, inclusion, and equity with attention to vulnerable populations, including women and female children. CQC prohibits any form of discrimination, harassment, or assault, all being grounds for dismissal of employment, separation from the contract, an immediate discreet investigation of the reported incident, and where warranted, reports to the applicable authorities.

CQC abides by the labor laws in the countries where we operate and contract individuals, the project proponent, and implementing partners welcome any beneficiary who requests our project services and is committed to the stated terms and conditions of project participation.

2.2.6 Worker Training

CQC understands that a new job is exciting and at times can be overwhelming. CQC has teams worldwide, U.S.A., Australia, India, Malaysia, and in-country teams in locations where our projects are implemented. CQC and its affiliates understand the importance of employee and contractor contribution and providing the finest quality services to our clients, our reputation and continued expansion of benefits depend on client satisfaction which is connected to our employees and contractors.

CQC provides a detailed employee handbook. It details (i) the way CQC works, (ii) pay and progress, (iii) time away from work and other benefits, (iv) on the job conduct, (v) data security, (vi) safety in the workplace, (vii) anticorruption, antibribery, and anti-terrorism procedures, among other elements.

Independent Contractors are contracted through the CQC and the contract reflects the workers have trained in the U.S.A. anticorruption laws before the start of their employment and contracting. CQC provides training to country managers and other team managers, as appropriate, once these individuals are trained, they are responsible for providing standardized and regularly revised training and guidance to the teams they oversee and are trained by CQC in a train-the-trainer model. The contractors are also

responsible for providing training to the household’s primary cooks in construction, maintenance, and best practices in using the TLCRS before the registration of the stove.

The training that is provided to the independent contracts by CQC is a two-day extensive training with ‘in-the-classroom’ education and the second day of on-the-ground training. The agenda topics for day one include: Review of the Program, information about CQC, The process, the purpose of the training, expectations, roles and responsibilities, basics of climate change, the impact of traditional fires, heat science, Details of the Stove, Registration & Verification. The agenda topics for day two include: time to travel to-from the village for stove implementation, group building of stoves, discussion of maintenance of stoves, construction of stoves in smaller groups, and wrap-up.

Training materials are in flux as CQC makes edits to the stove design or other identified areas where the training needs to be redesigned.

Topics in the training that relates to the SDGs include education on climate change, health, and nutrition benefits of stove adoption, while having the double benefit of educating implementors on these topics, so they can engage in educated decisions in their day-to-day lives. The first day of training involves the description and visualization (PowerPoint) of how to construct the stove and the second day of training is when the project’s workers are trained directly in villages on how to construct the stove. The coverage and hands-on training build locally useful skills and knowledge to increase local participation in project implementation. These trained trainers go on to provide sensitization campaigns and training of each beneficiary, so the benefits are amplified.

2.2.7 Equal Work Opportunities

CQC makes every effort to abide by the laws and regulations of the countries we operate in, as well as, US law, and international statutes, as applicable. When conducting recruitment, CQC prioritizes hiring local community members and offers new opportunities to project beneficiaries as CQC expands operations and job openings arise.

This priority demonstrates CQC’s reverence for the deep understanding of cultural nuances that only local community members could hold and this quality in addition to the ability to take initiative and work independently are primary qualifications CQC seeks in candidates. CQC also seeks to mirror the percentage of women/men in the country in its in-country workforce, making all efforts to hire women candidates for all levels of positions.

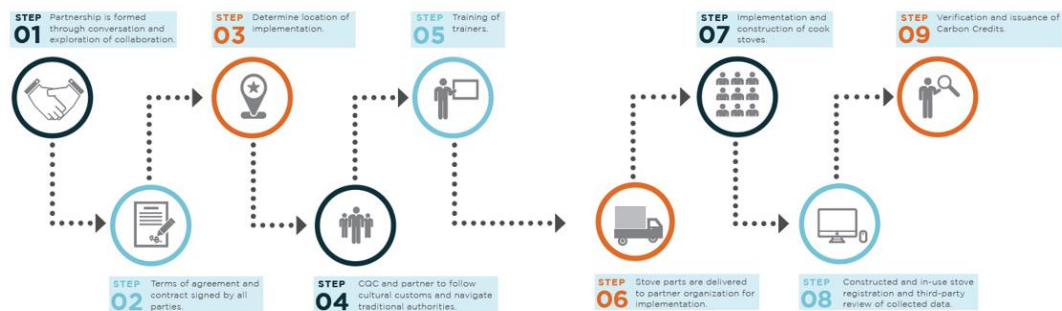

Image 3: Steps of Project Cycle that include identification of equal work opportunities, partnerships, and training.

2.2.8 Workers' Rights

The contractor, synonymous with implementing partner, enters into an independent contractor agreement with CQC. The agreement contains details of CQC's and the contractor's compliance with laws including, national, sub-national, state, and local, and does not exclude policies, laws, rules, and regulations, including the United States Foreign Corrupt Practices Act. Specific information is provided on anti-terrorism and anti-corruption efforts, including a code of conduct.

Per the Core Labour Conventions of the International Labour Organisation (ILO), CQC, respect, and work in tandem with the elimination of all forms of forced or compulsory labor, the effective abolition of child labor, minimum age convention, the right to organize, and the elimination of discrimination in respect of paid positions and occupation.

2.2.9 Occupational Safety Assessment

To mitigate the rare yet potential occupational safety hazards, CQC makes every effort to contract workers who have lived in the community for several years, this assists in mitigating the occupational hazards through community familiarity, language fluency, and native to the culture. This understanding of traditional values, respect, and working environment in the communities CQC serves support reduction of safety hazards. CQC provides Group Personal Accident insurance to our office staff.

Occupational Safety Hazards that have been identified are transport-related accidents, theft of parts, corruption, and jealousy of CQC contractors by their community counterparts. Transport-related accidents involve vehicle, motorbike, and bicycle accidents. CQC provides these modes of transportation to their contracts where necessary. Ultimately, the infrastructure conditions, whether through road constructions or road disturbances (loose animals, poor weather, i.e., rain) cause hazards that are not isolated to work through CQC but a hazard existing country-wide. Other hazards include theft of parts which has been mitigated by the collection of parts by a health promoter.

Risks are assessed and mitigated where possible and workers, stakeholders, and others directly involved with the projects are made aware of the potential risks and opportunities to mitigate where possible, yet it should be noted that paid positions or use of the stove do not increase the safety risks that are already present in the landscape of the country.

2.2.10 Feedback and Grievance Redress Procedure

CQC's Feedback and Grievance Redress Policy and Procedure ensures that project-affected communities and individual grievances are properly prioritized and addressed. These measures are taken to enhance CQC's accountability and transparency and to support the project initiatives should the community identify adverse effects to them, their communities, or their environment that has not been previously identified and mitigated by CQC. The full grievance redress policy and the procedure is available upon request and detailed in short below:

The first step of a complaint is typically applied to the informal procedure, where the affected person discussed the identified issue or provides feedback with the Field Coordinator or another member of the management team. The Field Coordinator attempts to resolve the grievance immediately on an informal basis, seeking advice from other parties (Area Development Committee, etc.) where necessary. The Field Coordinator and affected person work together to as immediately as possible, solve the identified issue.

This informal procedure does not prevent an individual or community from procedure immediately to the formal complaint process at any time.

The formal process requires the grievance to be filled in a written form, with the form available at the TA's office and collected by the CQC Field Coordinator. If literacy is a barrier, or other barriers exist such as distance to the TA's office, a telephone call to the CQC Direct office in Lilongwe is recommended where the grievance will be captured and recorded in written form by a staff member at the office. The CQC Direct office number is available to all project beneficiaries on brochures and posters provided at registration and during community sensitization.

All grievances are to be assessed and an update is provided to the grievant within 10 days. Three options for procedure guide CQC Direct's response (a) resolution is offered immediately according to the request made by the grievant; (b) resolution is more complex and requires additional consideration or extraordinary resources will lead to the grievant invited to a meeting to discuss options; and (c) where the complaint cannot be resolved through a meeting an investigation is arranged within 1 week (7 days) to gather additional information, led by the Field Coordinator, followed by a grievance hearing within 10 working days of the completed investigation.

Formal grievances are recorded in summary and shared with CQC to identify if the complaint is a project-wide issue that necessitates a system change in implementation.

2.2.11 Feedback and Grievance Redress Procedure Accessibility

The CQC Grievance Policy and Procedure is accessible as a phone number is available on the brochure left with each household, the most accessible manner to provide feedback. Formal copies are available in the Traditional Authority (TA) offices. Additionally, the grievance policy and procedure are verbally described during courtesy calls to TA's and the Area Development Committee (ADC).

2.2.12 Stakeholder Access to Project Documentation

In addition to an enhanced focus on verbally communicating among CQC implementing partners, staff, and local community members, CQC will include links to monitoring reports on our website. CQC posts annual reports online in addition to project descriptions. Efforts are made to publish links to these materials across CQC's social media footprint.

2.2.13 Information to Stakeholders on Assessment Process

CQC informs the beneficiaries and their families that they are participating in a project that distributes the TCLRS improved cookstove at an in-kind donation (labor and bricks constructed from locally available resources) to improve their respiratory health, food security, family economy through reduced cost of firewood and times saving, and the environment. We also inform them of our need to track their successes and monitor key data, such as money spent on wood fuel and/or time spent collecting wood fuel, among other indicators. As CQC is committed to cultural integrity but must ensure the integrity of the project and programs, auditors, and stove champions, visit the families up to 2 times after implementation.

As the SD VISta program progresses, the main forms of communication to stakeholders will be through stove champions, social media, and the CQC website. We will announce our participation through training, community sensitization programs, social media, public releases, and our website.

2.3 Project Management

2.3.1 Avoidance of Corruption

CQC and/or its affiliates and subsidiaries, as the primary project proponent, and those entities contracted as implementing partners, are committed to combating any form of corruption, bribery, embezzlement, fraud, favoritism, cronyism, nepotism, extortion, and collusion. CQC's employees sign a code of business ethics and conduct form that mandates performance of all duties with honesty, integrity, and impartiality, without improper preferential treatment of any person, and undergo mandatory anti-corruption and antibribery training as a condition of employment. CQC's implementation partners are required to review CQC's anti-corruption and anti-bribery policies and must take anticorruption and antibribery training before performing any project implementation services as a condition of their contract.

2.3.2 Statutory and Customary Rights

CQC operates from private homes, enhancing remote employment capabilities, and a central office location in Washington, D.C. U.S.A. Community sensitizations and training take place either on public land, i.e., a central town meeting point, or on private property with the explicit verbal invitation of the homeowner. The CQC implementing partners enter the kitchen space of the household to install the TCLRS only with the explicit permission of the household. Stove installations take place within rural areas of Malawi, and for the most part exclude the urban and peri-urban settings, although other projects will focus on these geographical areas in the future. CQC and its implementing partners take active consideration of individual and collective rights to ensure all rights are respected.

Land tenure in Malawi is divided into three categories: public, private, and customary lands. Public land is held by the government and used for purposes such as forest reserves, national parks, recreation areas, and conservation areas. Private land is exclusively owned or leased by entities. Customary land is any land falling under the jurisdiction of traditional authority, which can then grant that land to individuals, families, or communities for use under customary law.

Forests can fall into any of the three land tenure types. Mwase et al (2007) describe how both public and customary lands are, in practice, accessible and openly used for fuelwood extraction, despite protected status as forest reserves or control by chiefs as customary lands.

Malawi is divided into 28 districts which are overseen by District Commissioners and DEC. It is further divided into 250 Traditional Authorities, which are governed by the Chief and associated ADC. Each Traditional Authority contains multiple villages, which are overseen by Group Village Heads and VDCs.

Customary lands are central to the identity and livelihood of villages, and all smallholder production takes place on customary lands that have been allocated to households by Group Village Heads for subsistence cultivation. Governance of customary lands is overseen by Traditional Authorities, who grant the power to chiefs and Group Village Heads to distribute lands to smallholders. However, in practice, customary lands are typically treated as open access to all village members, with few restrictions or harvest limits.

Project activities take place on customary lands within villages that have been allotted to individual households by Group Village Heads. All project participants have tenure rights associated with the land the ICS is built.

2.3.3 Recognition of Property Rights

CQC's implementing partners only install a stove at the informed invitation of the household and CQC's ICS does not infringe or interact with property rights.

2.3.4 Free, Prior, and Informed Consent

The project activities will take place with the approval of Village Development Committees and Area Development Committees in a series of consultation meetings as documented. In addition, ICS is a completely voluntary activity and households in participating villages are free to choose whether they take part or not. Free, prior, and informed consent takes place before installation.

2.3.5 Restitution and/or Compensation for Affected Resources

CQC's installation of an ICS does not affect any party's access to resources or their lands; no negative effects have been identified.

2.3.6 Property Rights Removal/Relocation of Property Rights Holders

CQC's ICS installation does not impede, involuntarily remove, or relate the land or property rights of the beneficiaries or their families. ICS installation incentivizes the beneficiaries to end the use of three-stone fires and relocate cooking activities to the ICS. While this may restructure the cooking activity that is important to culture and livelihood, post-implementation surveys of beneficiaries suggest that the ICS

allows them to decrease cooking times while making identical culturally appropriate foods. This is seen as technology adaptation not removal or relocation of important cultural activities.

The project activities do not involve the removal or relocation of property rights holders from lands or territories, nor do they force rights holders to relocate activities. All bamboo planting and ICS activities are voluntary.

2.3.7 Identification of Illegal Activities

Theft and corruption are commonly identified as illegal activities in Malawi. As there is no transfer of funds at the beneficiary level, the cost of the stove is through in-kind contributions from the beneficiaries. Theft of metal stove parts has occurred in the past and CQC has since implemented secure storage and direct hand-off of stove parts to reduce this occurrence.

2.3.8 Ongoing Conflicts or Disputes

There are no identified ongoing conflicts or disputes as the project scope does not involve rights to lands, territories, and resources. As the project implementation takes place within the private household, project activities would not interfere with the outcome of an unresolved dispute.

2.3.9 National and Local Laws and Regulations

CQC follows the Malawi Companies Act adhering to subsequent local and national laws. Project Implementors are registered with appropriate national authorities allowing them to conduct their operations, with CQC projects as an add-on. Relevant and applicable international and U.S. statutes and regulations are abided by.

2.3.10 Project Ownership

Beneficiaries agree to allow CQC to do the following:

- (1) Claim the GHG emission reduction and/or removals generated by the technology used by the CC ICS project.
- (2) Conduct follow-up and spot audits for increased adoption and monitoring purposes.

The stoves themselves are owned by the beneficiaries with in-kind contributions, including making and constructing the bricks for the construction of the TLCRS.

2.3.11 Grouped Projects

With CQC's group projects, secondary projects are identified through stakeholder assessment and development initiatives at the community level that we can meet. New project activities are assessed and evaluated to determine if they provide significant individual impacts (funding of education), household (cookstove), or community level (training on climate change, the importance of health and nutrition particularly of pregnant individuals and during the first 1000 days). Where projects are seen to provide significant impact, design is assessed for scalability and risk, with a focus on added values to in-country contracting, and transferability to other countries in sub-Saharan Africa. Following, new project activities are evaluated against current projects in their thematic buckets to determine if CQC and IPs have the

bandwidth to take on additional projects. If acceptable, pilot projects on a small scale may begin to evaluate the implementation and identify necessary changes. CQC remains committed to being flexible with the addition of new projects so long as current projects continue on their projected timelines and anticipated impact and benefit to the beneficiaries.

3 BENEFITS FOR PEOPLE AND PROSPERITY

3.1 Condition of Stakeholders at Project Start

As smallholder subsistence agriculture farmers, the stakeholders in Malawi are especially susceptible and vulnerable to the impacts of the climate crisis. As a landlocked country with over 20 million people, high population density, and a growing demographic, deforestation and degradation and widespread soil erosion are growing concerns to the agriculture-based economy that has experienced decades of increasing climate shocks.¹⁸

Traditionally households use TS, contributing to 15% of global energy use, large amounts of black carbon, and carbon-based greenhouse gases.¹⁹ Biomass for the cookfires is mainly locally procured firewood. This firewood is typically large diameter logs that the women and children, primarily girls, are responsible for collecting. As the population has increased and rapid deforestation results, where the industry is also a contributor, women, and children have had to travel farther distances to gather firewood for their three-stone cookfires. Cooking on three-stone cookfires occurs in a closed walled building, made from locally available resources. With these low-efficient cookfires, women and children are exposed to HAP for extended durations, resulting in high levels of COPD, asthma, and other negative respiratory effects.²⁰ Due to the long cook times of the inefficient cookfires, nutrient-dense foods breakdown and consumption occurs at a lower nutrient level.

3.2 Expected Impacts on Stakeholders

Impact #1	<i>Ability to cook using TLCRS</i>
Type of Impact	<i>Positive, actual, direct</i>
Affected Stakeholder Group(s)	<i>Beneficiaries, beneficiaries' families</i>

¹⁸ MALAWI CLIMATE CHANGE FACT SHEET (2016).

¹⁹ Jeuland & Pattanayak, (2012).

²⁰ Rosenthal, et al., (2017).

Resulting Change in Well-being	<i>Decreased reliance on wood fuel, specifically from live trees, to meet equivalent thermal energy needs for cooking purposes and switching to abundant sources of woody biomass such as small branches and twigs from perennial shrubs, agroforestry, and crop residues. This results in a direct freeing up of time/money resources for other income-generating activities, health benefits due to reducing exposure to smoke in the home, increased food security due to nutrient retention with decreased cook time.</i>
---------------------------------------	---

Impact #2	<i>Improved Health Status</i>
Type of Impact	<i>Positive, Predicted, Direct</i>
Affected Stakeholder Group(s)	<i>Beneficiaries, Beneficiaries' families, specifically children and infants under 5 years old</i>
Resulting Change in Well-being	<i>Lowered risk of developing COPD or worsening COPD, less instance of acute lower respiratory illness, anticipated reduction of burns due to contained flames in the combustion chamber, improved overall respiratory health, increased ability to consume safe drinking water with reducing boiling water time.</i>

Impact #3	<i>Reduction of time spent on unpaid domestic work</i>
Type of Impact	<i>Positive, Predicted, Direct</i>
Affected Stakeholder Group(s)	<i>Beneficiaries (most notably, female, elderly, and children, primarily girls)</i>
Resulting Change in Well-being	<i>Females who spend a copious amount of time on unpaid domestic labor, multiplied by the double/triple burden effect, have a predicted time saving which can be redirected to income-generating activities or relaxation time, contributing to enhanced conditions for gender equity.</i>

Impact #4	<i>Improved Economic Outcomes</i>
Type of Impact	<i>Positive, Predicted, Direct</i>

Affected Stakeholder Group(s)	<i>Beneficiaries, Beneficiaries' Families, primarily female children</i>
Resulting Change in Well-being	<i>Families predict money and times savings with fuel efficiency reducing costs of firewood purchases and/or time savings on the collection of wood. Investments in the VSL are made by CQC and allocated funds are distributed to projects identified by the village members.</i>

3.3 Stakeholder Monitoring Plan

The CQC TLCRS project and the secondary projects that are related and connected to the implementation and adoption of the ICS are intended to have direct household-level change with a scope of a results-based theory of change framework. With CQC's inspection matrix, that will see up to 7 visits – from CQC spot audits, stove champions visits, various VVB audits for Verra projects, and project donors' independent audits - to beneficiaries per year on a sample size selection, beneficiaries, and prospective beneficiaries, the primary and direct stakeholders, have the opportunity to provide feedback on predicted, direct or indirect, positive or negative effects that have been identified or not yet isolated in the project's causal chain. For the indirectly impacted stakeholder, CQC will approach them on an annual basis to provide feedback on project variables, claims, impacts, etc. Throughout the project and at any point of the year, CQC welcomes feedback from direct and indirect stakeholders. For indirect stakeholders, a feedback form will be available on our website and direct stakeholders have various avenues to connect with Malawi implementing partners and CQC Direct. This will ensure continuous monitoring and collection of effects that are considered by CQC, and appropriate mitigation steps are taken in project design if unintended negative impacts arise.

Stakeholder monitoring with CQC is collected through a cloud-based app. In-house designed surveys are built with attention to stakeholders' improvements and ensuring intended benefits play out in the real-life application of the ICS. With SC visits, maintenance and additional educational services are often included, conducted entirely in the native language of the beneficiary.

Community Sensitization and Training Visit

Implementing partners identify and visit villages to hold discussions with the village leader and leaders of women's groups, the project, and its benefits – climate-related, health, and nutrition, are briefly discussed and any questions are addressed. Following, a community-wide training session is held to introduce the project to all interested households, training includes information on the multiple benefits and multiple projects that start with the initiation of the ICS and ventilation of the kitchen. Households receive a demonstration of how to build the bricks and construct the exterior shell of the ICS. Brick moulds are provided to the village to support the construction of bricks in the interim. The implementing partner identifies prospective beneficiaries and evaluates the installation sites during these Sensitization and Training visits. Prospective beneficiaries receive a TLCRS Guideline Brochure that provides the details on brick construction in pictographs and local language for universal understanding (see appendix B and C). *Information provided: Community Training Materials*

Installation Visit

Enumerators visit households that have constructed the exterior shell of the stove using locally available materials (water, anthill clay, sand, clay, and cow dung). Metal parts are assembled, and additional education and maintenance instructions are provided to the household. The double stoves are registered using Android-based phones or tablets. Registration involves collecting stove data (QR card registration, photographs of the stove construction, contract information of the beneficiary, and GIS location of the stove) and responding to any initial questions from the beneficiary. *Survey: Registration Questionnaire*

Stove Champion Visit 1

All stoves are visited by the IPs targeted at the end of the wet season for completed project sites (villages) and within 6 months of installation in the year, stoves are installed in specific project sites. This is to occur on an annual basis. Surveys are conducted with additional education and maintenance instruction provided. Visits are scheduled post-wet season to provide hands-on instruction on stove maintenance which may be damaged due to floods and storms. Extra addition is provided on the benefits and best practices in use, maintenance, and ventilation. *Survey: Stove Champion Audit Questionnaire*

Stove Champion Visit 2

Visits are performed annually but are operationally dependent and targeted for the end of the dry season. 100% of stoves may be visited, but the second stove champion visit is done on a best-effort basis and locations are driven by IP-specific logistical arrangements on the ground. This is considered a higher standard than the market, which does not model even a first stove champion visit, as such visit 2 is seen as a value-add improvement tool that collects and monitors stakeholder improvements and feedback on projects. *Survey: Stove Champion Tailored Questionnaire (adapted to collect any pertinent information on SDGs and anecdotal information IPs have been exposed to)*

CQC Spot Audit A

Visits are performed annually during the first four years, identified as the deployment phase and at the initial installation phase of each IP. The sample size is typically 25-30 households, but larger samples can be conducted if there is a reason. The primary reason for these spot audits is to ensure IP performance and evaluate the use and knowledge of the ICS from the households. IPs are given 10 days of notice before an audit but only 24 hours' notice of where the actual visits will occur to ensure no comprise of the data, if there is a severe concern of IPs performance, unannounced audits may also take place. The sample size is identified by CQC based on the GPS location of registered stoves. Upon conclusion of the spot audit, performance improvements can be recommended including retraining and special remediation, if necessary. Failure to address issues may lead to the termination of the IP contract. *Survey: Base of TLCRS Spot Audit Questionnaire, but questions can be added or altered depending on identified or suspected concerns with IP performance.*

CQC Spot Audit B

To ensure the highest quality of low-carbon emission climate-resilient development projects, CQC undertakes a second spot audit, which is a self-imposed higher than required, by VERRA or other market actors, practice. This is put into action follow Audit A and targeted to relevant IPs because of poor findings during Audit A. The intent is to target inspection and questionnaire about the stove's installation, explanation, and use. If serious issues are observed, further remediation action will be dictated to the IP. If issues continue and remediation efforts do not produce impacts, the IP may be terminated. *Survey: TLCRS Spot Audit B*

CQC Remediation Audit

The remediation audit occurs on an as-needed basis and is triggered if spot audits A and B identify serious underperformance issues with an IP. CQC staff typically conduct these leadership-level visits and engage on critical issues. Results will lead to either direct retraining or other corrective issues of the IP or will result in IP termination. This process was built because of years of refinement by CQC as intended to ensure that IPs are held to account and underperformance is managed, if not remediable, then termination of IP is triggered. CQC and the County Manager are constantly building a pipeline of potential IP partners to ensure that it can, in practice, terminate an IP and replace it with another to cover the relevant region if poor performance is not remedied. *Survey: Remediation Audit Survey, individualized to identified issues observed in spot audit A and B.*

Examples of Stakeholder Monitoring Questions

The following are lines of questions that are included for stakeholder monitoring purposes and collect information on the intended direct and indirect benefits and any unidentified negative outcomes:

- What do you remember most about the training?
- What do you like most about the stove?
- What difficulties do you have with using the stove?
- Would you recommend the stove to your neighbors/friends/family?
- Collection of other comments from the beneficiary that should be transferred to CQC.

3.4 Net Positive Stakeholder Well-being Impacts

Impact #1	<i>Ability to cook using TLCRS, improved health status, improved nutrition status, improved economic outcomes, reduction in time spent on unpaid domestic labor</i>
Type of Impact	<i>Positive, Predicted/Actual, Direct</i>
Affected Stakeholder Group(s)	<i>Beneficiaries (primarily women), beneficiaries' families (primarily children, particularly girls).</i>

Resulting Change in Well-being

Decreased reliance on wood fuel, specifically from live trees, to meet equivalent thermal energy needs for cooking purposes and switching to abundant sources of woody biomass such as small branches and twigs from perennial shrubs, agroforestry, and crop residues. This results in a direct freeing up of time/money resources for other income-generating activities, health benefits due to reducing exposure to smoke in the home, increased food security due to nutrient retention with decreased cook time.

Lowered risk of developing COPD or worsening COPD, less instance of acute lower respiratory illness, anticipated reduction of burns due to contained flames in the combustion chamber, improved overall respiratory health, increased ability to consume safe drinking water with reducing boiling water time.

Females who spend a copious amount of time on unpaid domestic labor, multiplied by the double/triple burden effect, have a predicted time saving which can be redirected to income-generating activities or relaxation time, contributing to enhanced conditions for gender equity.

Families predict money and time savings with the fuel efficiency reducing costs of firewood purchases and/or time savings on a collection of wood.

4 BENEFITS FOR THE PLANET

4.1 Condition of Natural Capital and Ecosystem Services at Project Start

The condition of natural capital and ecosystem services in Malawi on or around the start of the project has been described as a tipping point for deforestation. With 89% of Malawian's dependent on wood biomass to meet their energy needs, at the current rate of deforestation, it is estimated that Malawi would be stripped of all of its trees as early as 2079, with some projects earlier than this date due to the rapid growth in population size (203 people/km in 2020 vs. 118 in 2000) and a large portion of the population in younger aged individuals (median age is 18.1 years old) and a growing life expectancy of 60+ years from 2020 up from 40+ years in the early 2000s. As of 2000, 12% of Malawi had natural forest cover – 1.45Mha natural forest, 94.7Kha as plantations, and 10.3Mha non-forest. However, there is no intact forest in Malawi, defined as “unbroken expanses of natural ecosystems within the zone of forest extent that show no signs of significant human activity and are large enough that all native biodiversity, including viable populations of wide-ranging specifics, could be maintained.”²¹

Although the cutting of trees for commercial use is illegal in Malawi it has been fuelled in recent years by the urban migration (18%+ and growing rapidly) and the urban demand for charcoal in tandem with the international demand for hardwoods. This rapid deforestation has led to increasing catastrophic impacts on biodiversity, ecosystem, weather patterns, climatic shocks, and wildlife. In 2016, the government of Malawi deployed armed forces to protect forest reserves that were being heavily targeted by illegal logging efforts. Between 2019 and 2020, there was a rapid increase in the loss of 102ha of primary forest.²²

Since 2000, Malawi has lost 193kha of tree cover, equivalent to a 13% decrease and 52.3Mt of CO₂ released into the atmosphere. Since 2002, Malawi has lost 420ha of humid primary forest, making up .22% of total tree cover loss, with a total area of humid primary forest decrease of 8.0% at the same time. Between 2010-2020, a total of 9.39MT of aboveground biomass was released into the atmosphere because of tree cover loss, equivalent to 854kt per year. At the same time, a total of 17.2MT of CO₂ was released into the atmosphere because of tree cover loss, equivalent to 1.56Mt per year.

²¹ Global Forest Watch. “Emissions from biomass loss in Malawi”. www.globalforestwatch.org.

²² Global Forest Watch. “Emissions from biomass loss in Malawi”. www.globalforestwatch.org.



Image 4: Map of Malawi from Global Forest Watch sections identify tree cover

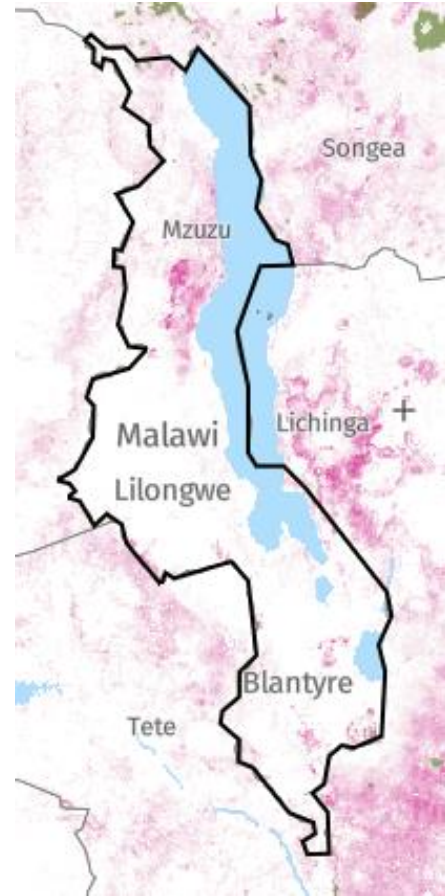

Image 5: Map of Malawi from Global Forest Watch Green the pink color depicts tree cover loss

4.2 Expected Impacts on Natural Capital and Ecosystem Services

Impact #1	<i>Reduced demand for large diameter non-renewable firewood from live trees due to only needing finger-sized woody biomass, i.e., twigs and crop residues, for cooking on the TLCRS</i>
Type of Impact	<i>Positive, actual, direct</i>
Affected Natural Capital and/or Ecosystem Service(s)	<i>Biodiversity and Species Richness, Soil and Water Conservation</i>
Resulting Change in Condition	<i>By slowing the consumption of woody biomass for cooking purposes and by eliminating the need for large diameter woody biomass due to the technology in the TLCRS, the resulting drop in demand slows deforestation, thus increasing the renewable energy share in the total final energy consumption of the project area.</i>

Impact #2	<i>Avoided deforestation of the forested area due to wood fuel savings made possible by the TLCRS</i>
Type of Impact	<i>Positive, predicted, indirect</i>
Affected Natural Capital and/or Ecosystem Service(s)	<i>Biodiversity and Species Richness, Soil, and Water Conservation</i>
Resulting Change in Condition	<p><i>Slow the negative annual net change rate of forest area in Malawi, increase forest area as a proportion of the total land area.</i></p> <p><i>Generate increased knowledge and interest in avoided deforestation through education of sustainable forest management and collection of small-diameter woody biomass, twigs, and crop bi-product (corn husks).</i></p>

4.3 Natural Capital and Ecosystem Services Monitoring Plan

In addition to monitoring the ICS implemented each year, CQC will monitor the following to evaluate the net ecological impact of the project:

- Survey the amount of woody biomass used to fuelwood to meet the thermal energy needs for meal preparation on the TLCRS and calculate the reduction in woody biomass used in comparison to a three-stone open cooking fire.
- Use annually available data from the Global Forest Watch to calculate the ha of forest area that would have otherwise been logged for wood fuel. Specifically, mirroring the annual data provided in Section 4.1 and determine the impact year-over-year.

Natural capital use will also be monitored through fuel use studies contracted by CQC to academic partners. Through these studies, CQC will ascertain the natural capital savings, specific to impacts 1 and 2 in the above charts.

4.4 Net Positive Natural Capital and Ecosystem Services Impacts

By replacing three-stone cooking open fires and other traditionally used fuel-inefficient cook fires with ICS technology the primary project activity, will generate an estimated 50 tCO_{2e} GHG emission reduction over the ten-year project crediting period.

APPENDIX

References

Appendix A: Causal Chain

Appendix B: Beneficiary Brochure (Chichewa – most common language in Malawi)

Appendix C: Beneficiary Brochure (English)

References

- Amegah A. K. (2020). Improving Child Survival in Sub-Saharan Africa: Key Environmental and Nutritional Interventions. *Annals of global health*, 86(1), 73. <https://doi.org/10.5334/aogh.2908>
- Berkeley Air Monitoring Group (2020). *Effects on gender-related outcomes after the introduction of improved cookstoves in rural Zambia*. http://www.carbonmarket-foundation.org/userfiles/zdk/file/CQC_BA_Zambia_Gender%20Impacts_vF2%20copy.pdf 1-28.
- Bervoets, J., Eveillé, F., & Thulstrup, A. (n.d.). *Improving nutrition through enhanced energy access*. 4. <http://www.fao.org/3/I9967EN/i9967en.pdf>
- Clean Cooking Alliance (n.d). Delivering on the Sustainable Development Goals through Clean Cooking. <https://www.cleancookingalliance.org/feature/delivering-on-the-sustainable-development-goals-through-clean-cooking.html>,
- Das, K., Pradhan, G., & Nonhebel, S. (2019) *Human energy and time spent by women using cooking energy systems: A case study of Nepal*. <https://doi.org/10.1016/j.energy.2019.06.074>
- FAO (2017) *Sustainable woodfuel for food security – A smart choice: green, renewable and affordable*. <http://www.fao.org/3/i7894e/i7894e.pdf>
- Hyder, A., & Behrman, J. R. (2014). Female economic activity in Rural Malawi. *Journal for Development and Leadership / Nelson Mandela Metropolitan University*. Nelson Mandela Metropolitan University, 3(1), 1–10. <https://www.ncbi.nlm.nih.gov/pmc/articles/PMC4480682/>
- Jeuland, M. A., & Pattanayak, S. K. (2012). Benefits and Costs of Improved Cookstoves: Assessing the Implications of Variability in Health, Forest and Climate Impacts. *PLoS ONE*, 7(2), e30338. <https://doi.org/10.1371/journal.pone.0030338>
- MALAWI CLIMATE CHANGE FACT SHEET | Fact Sheet | Malawi | U.S. Agency for International Development. (2016, September 26). <https://www.usaid.gov/malawi/fact-sheets/malawi-climate-change-fact-sheet>
- Malawi: Location, map, and cities. (n.d.). Retrieved May 17, 2021, from <https://www.geodatos.net/en/countries/malawi>
- Mortimer, K., Ndamala, C. B., Naunje, A. W., Malava, J., Katundu, C., Weston, W., Havens, D., Pope, D., Bruce, N. G., Nyirenda, M., Wang, D., Crampin, A., Grigg, J., Balmes, J., & Gordon, S. B. (2017). A cleaner burning biomass-fuelled cookstove intervention to prevent pneumonia in children under 5 years old in rural Malawi (the Cooking and Pneumonia Study): a cluster randomized controlled trial. *Lancet (London, England)*, 389(10065), 167–175. [https://doi.org/10.1016/S0140-6736\(16\)32507-7](https://doi.org/10.1016/S0140-6736(16)32507-7)
- Parrish, R., Colbourn, T., Lauriola, P., Leonardi, G., Hajat, S., & Zeka, A. (2020a). A Critical Analysis of the Drivers of Human Migration Patterns in the Presence of Climate Change: A New Conceptual Model. *International Journal of Environmental Research and Public Health*, 17(17), 6036. <https://doi.org/10.3390/ijerph17176036>
- Parrish, R., Colbourn, T., Lauriola, P., Leonardi, G., Hajat, S., & Zeka, A. (2020b). A Critical Analysis of the Drivers of Human Migration Patterns in the Presence of Climate Change: A New Conceptual Model. *International Journal of Environmental Research and Public Health*, 17(17), 6036. <https://doi.org/10.3390/ijerph17176036>

Rosenthal, J., Quinn, A., Grieshop, A. P., Pillarisetti, A., & Glass, R. I. (2018). Clean cooking and the SDGs: Integrated analytical approaches to guide energy interventions for health and environment goals. *Energy for Sustainable Development*, 42, 152–159. <https://doi.org/10.1016/j.esd.2017.11.003>

Vizzuality. (n.d.). *Malawi Deforestation Rates & Statistics* | GFW. Retrieved May 17, 2021, from <https://www.globalforestwatch.org/dashboards>

Appendix A: Causal Chain

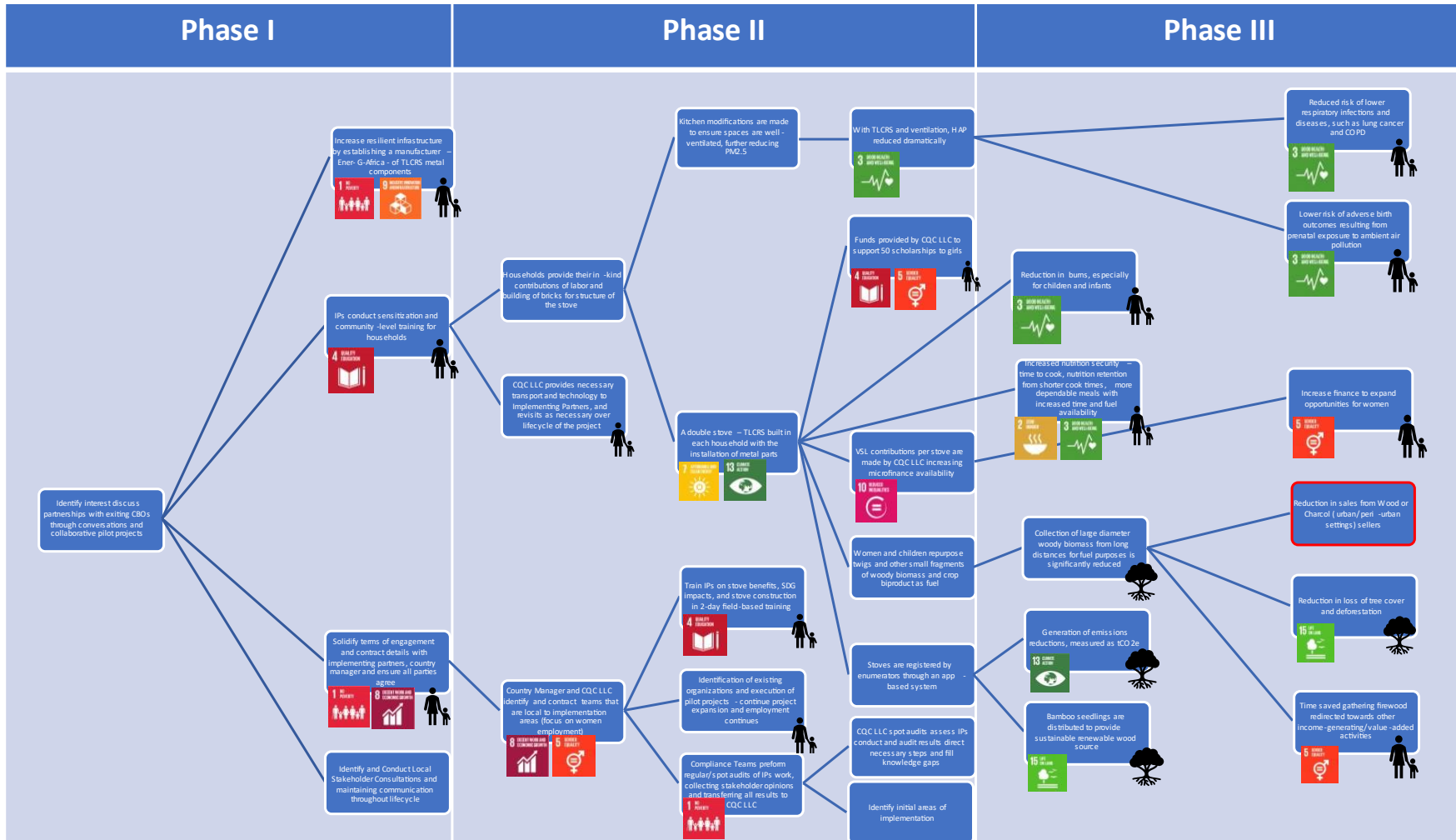

KEY

SDG Labels

Planet

People/ Prosperity

Negative Impact

Positive Impact

Appendix B: Brochure (Chichewa)

CQuestCapital
TLC-CQC ROCKET STOVE - GUIDELINES

MBAULA



NJERWA



MORTAR

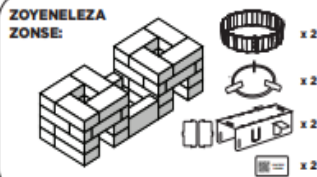

KUMANGA

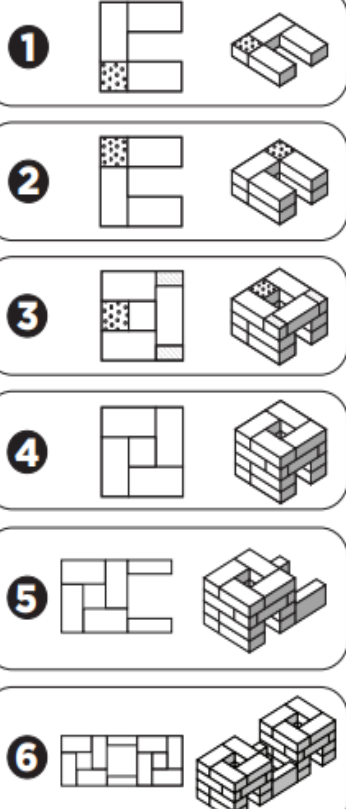

ZIPANGIZO

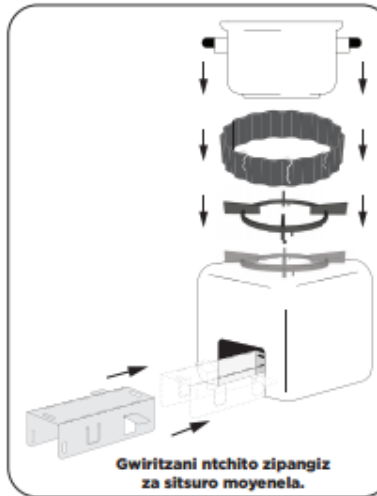

KHICHINI

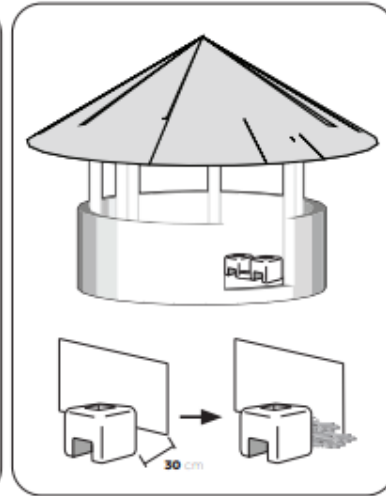

MAINTENANCE

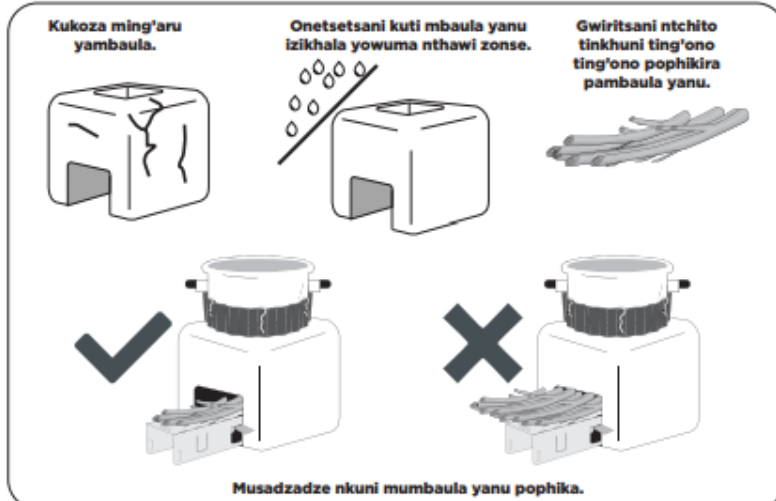

Appendix C: Brochure (English)

CQuestCapital
TLC-CQC ROCKET STOVE - GUIDELINES

STOVE

ITEMS YOU WILL NEED: 30 Bricks, 6 Halves, 4 Quarters, 10L Water, 6 Shovels: Sand, 6 Shovels: Clay, 2 Shovels: Cow Dung, 1 Brick Mold

BRICKS

ITEMS YOU WILL NEED: Water, Anthill Clay, Brick Mold

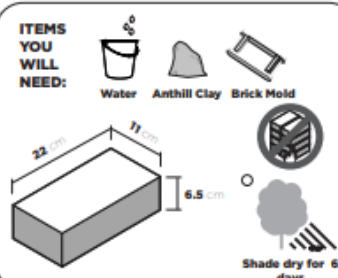

22 cm, 11 cm, 6.5 cm
Shade dry for 6 days

MORTAR

ITEMS YOU WILL NEED: 10L Water, 6 Shovels: Sand, 6 Shovels: Clay, 2 Shovels: Cow Dung

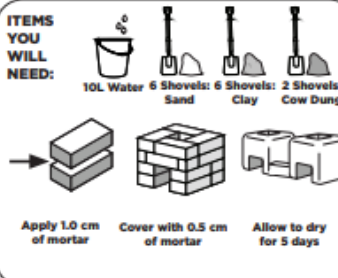

Apply 1.0 cm of mortar, Cover with 0.5 cm of mortar, Allow to dry for 5 days

CONSTRUCTION

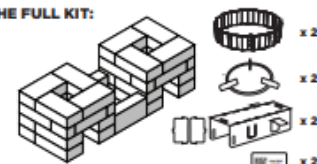
THE FULL KIT:  x2, x2, x2, x2

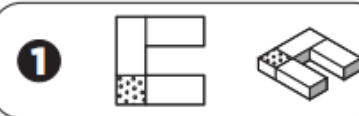
1 

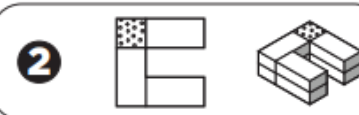
2 

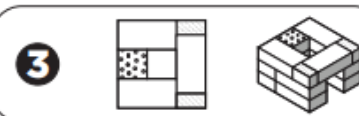
3 

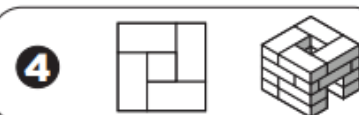
4 

5 

6 

PARTS

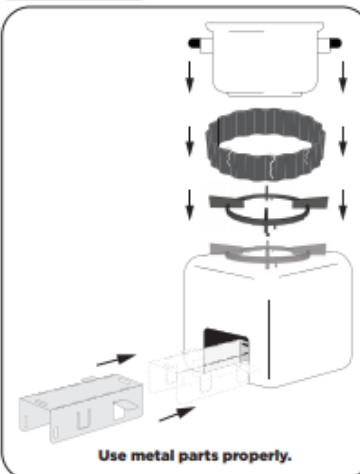

Use metal parts properly.

KITCHEN

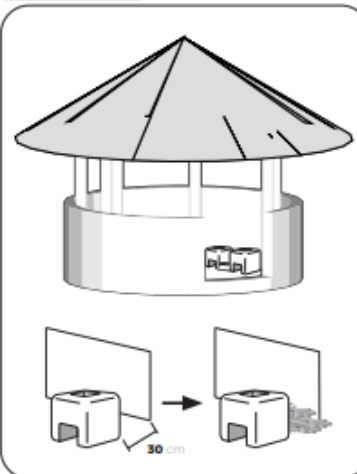

30 cm

MAINTENANCE

Repair all cracks. Keep stove dry. Use small diameter wood.

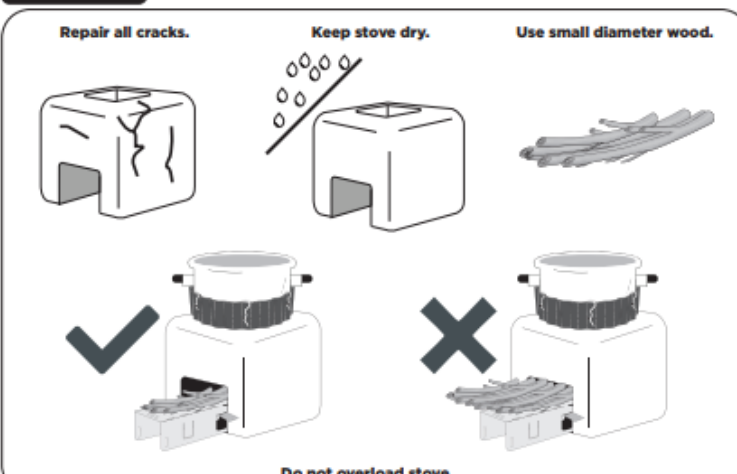

Do not overload stove.