



# Sustainable Development Verified Impact Standard

## INSTALLATION OF HIGH EFFICIENCY WOOD BURNING COOKSTOVES IN MALAWI – PROJECT 2



Document Prepared by C-Quest Capital LLC

1015 18th Street, NW Suite #730  
Washington, DC 20036

<b>Project Title</b>	Installation of high efficiency wood burning cookstoves in Malawi – Project 2
<b>Version</b>	04
<b>Date of Issue</b>	30 January 2023
<b>Project Location</b>	Republic of Malawi
<b>Project Proponent(s)</b>	<u>C-Quest Capital Stoves Asia Limited</u> Ken Newcombe, <a href="mailto:CQC-Operations@cquestcapital.com">CQC-Operations@cquestcapital.com</a> ; 1 (240) 491 – 2650 Sarah Stever, <a href="mailto:CQC-Operations@cquestcapital.com">CQC-Operations@cquestcapital.com</a> ; 1 (415) 290 - 1144
<b>Assessor Contact</b>	Carbon Check (India) Private Limited 2071/38, 2nd Floor, Naiwala, Karol Bagh, New Delhi-110005 URL: <a href="http://www.carboncheck.co.in">www.carboncheck.co.in</a> E-mail: <a href="mailto:info@carboncheck.co.in">info@carboncheck.co.in</a> / <a href="mailto:projects@carboncheck.co.in">projects@carboncheck.co.in</a> Contact #: +91 (120) 4373114
<b>Project Lifetime</b>	5 July 2020 to 4 July 2030, ten-year lifetime
<b>History of SD VISTA Status</b>	No previous attempts at SD VISTA certification made to date

<b>Other Certification Programs</b>	VERRA Verified Carbon Standard (2372)
<b>Expected Future Assessment Schedule</b>	Initial validation/verification anticipated in 2022

# CONTENTS

---

- 1 SUMMARY OF SDG CONTRIBUTIONS ..... 4**
  
- 2 PROJECT DESIGN ..... 8**
  - 2.1 Project Objectives, Context and Long-term Viability .....8
  - 2.2 Stakeholder Engagement ..... 19
  - 2.3 Project Management ..... 31
  
- 3 BENEFITS FOR PEOPLE AND PROSPERITY ..... 36**
  - 3.1 Condition of Stakeholders at Project Start .....36
  - 3.2 Expected Impacts on Stakeholders ..... 37
  - 3.3 Stakeholder Monitoring Plan ..... 40
  - 3.4 Net Positive Stakeholder Well-being Impacts ..... 51
  
- 4 BENEFITS FOR THE PLANET ..... 52**
  - 4.1 Condition of Natural Capital and Ecosystem Services at Project Start .....52
  - 4.2 Expected Impacts on Natural Capital and Ecosystem Services .....53
  - 4.3 Natural Capital and Ecosystem Services Monitoring Plan .....54
  - 4.4 Net Positive Natural Capital and Ecosystem Services Impacts ..... 56
  
- APPENDIX ..... 57**

# 1 SUMMARY OF SDG CONTRIBUTIONS

Row number	Estimated Project Contribution by the End of Project Lifetime	SDG Target	SDG Indicator	Net Impact on SDG Indicator	Section Reference	Claim, Asset or Label
1	<p>a) Promote sustainable agriculture by distributing drip irrigation kits in 2000 beneficiary households enabling efficient water management and increased household ability to grow crops/vegetables in dry season.</p> <p>b) Promote resilient agricultural practices that help maintain ecosystems and progressively improve land and soil quality by distributing approximately 268,273 bamboo seedlings to beneficiary households to be used as a perennial source of cooking energy in these households. The bamboo plants will not only provide sustainable wood fuel to households but will also improve soil quality.</p>	2.4	<p>Project specific indicator:</p> <p>a) Number of households receiving drip irrigation kits under project activity.</p> <p>b) Number of bamboo seedlings distributed amongst the beneficiary households</p>	Implemented activities to increase	3.2	SD VISta labeled VCUs

2	<p>The project activity by replacing 0.5 million traditional cookstoves with energy efficient project cookstoves will contribute to improved health and well-being brought about by reduced levels of fine particulate matter (PM<sub>2.5</sub>) emissions within households by approximately 47% below baseline emission level of 4.79 g/kg fuel<sup>1</sup>.</p>	3.9 <sup>2</sup>	<p>Number of individuals experiencing health benefits due to reduced exposure to indoor air pollution</p>	<p>Implemented activities to increase</p>	3.2	<p>SD VISTA labeled VCUs</p>
3	<p>The project will also lead to increasing vocational and relevant skills of local individuals by providing non-formal education and training on issues related to climate change, with specific skill building in operations and surveying activities related to stove distribution and its monitoring under VCS.</p> <p>The project through its targeted youth and women program will lead to training 50 number of individuals in its region of implementation</p>	4.3	<p>Project specific indicator: Number of individuals who received any informal training</p>	<p>Increase</p>	3.2	<p>SD VISTA labeled VCUs</p>
4	<p>Contribute to reducing drudgery and gender inequality, by saving upto 4 hours/week of the time spent by women and children in collecting fuel wood as against an average of 14 hours/week (2</p>	5.4	<p>Proportion of time spent on unpaid domestic and care work, by sex, age, and location</p>	<p>Decrease</p>	3.2	<p>SD VISTA labeled VCUs</p>

<sup>1</sup> PM<sub>2.5</sub> emissions from three stone fire. Source: [Clean Cooking Catalog \(cleancookstoves.org\)](http://cleancookstoves.org)

<sup>2</sup> <https://unstats.un.org/sdgs/metadata/>

	<p>hour/day<sup>3</sup>), in the baseline, for rural areas using an open fire or similar traditional cook stove.</p> <p>The project will lead to time savings and reduced drudgery in 0.5 million households translating to equal number of women as they are primary cooks and fuel wood collectors in most of the households. The women can use the time saved for doing more productive activities or personal care.</p>					
5	<p>Contribute to increasing access to clean cooking technology with TLC CQC Rocket Stove installations in around 0.25 million Malawian households that have been using traditional three stone fire, over the project lifetime.</p>	7.1	7.1.2 Proportion of population with primary reliance on clean fuels and technology	Increase	3.2	SD VISta labeled VCUs
6	<p>Contribute to generation of employment in informal sector (total economy, agriculture, and non-agriculture) by contracting locals with a target employment of 50 employees for varying lengths of time over the project lifetime with a focus on hiring females.</p> <p>Employment comprises all persons of working age who, during a short reference period (minimum one week), or full time will be engaged in any activity to</p>	8.3	8.3.1 Proportion of informal employment in non-agriculture employment, by sex	Increase	3.2	SD VISta labeled VCUs

<sup>3</sup> Determined through survey of target population

	produce goods or provide services for pay or profit.					
7	Contribute to increase in resilient economic infrastructure by assisting in establishing Ener-G-Africa (EGA), a stove part manufacturing unit in Malawi and to support sustainable industrialization by sourcing all manufactured metal parts for the project stoves from this unit.	9.3	Project Specific Indicator: Annual revenue of Ener-G-Africa that comes from CQC's stove part orders	Implemented activities to Increase	3.2	SD VISta labeled VCUs
8	Contribute to GHG emission reduction through an estimated reduction of ~75.46 tCO <sub>2e</sub> per stove due to replacement of baseline stoves with TLCRS over the crediting period	13.0	Project Specific Indicator: Reduction in GHG emissions as compared to the baseline scenario (open fire)	Increase	VCS verification report	SD VISta labeled VCUs
9	Contribute an estimated reduction in removal of woody biomass to the tune of ~3.9 tons per stove per year, from forests surrounding the communities thereby leading to an increase in above ground biomass in these forests.	15.2	15.2.1 Progress towards sustainable forest management by increasing above ground biomass in forests	Implemented activities to increase	VCS verification report	SD VISta labeled VCUs

## 2 PROJECT DESIGN

### 2.1 Project Objectives, Context and Long-term Viability

#### 2.1.1 Summary of Project Sustainable Development Objective(s)

C-Quest Capital LLC's (CQC) Improved Cookstove (ICS) project – “Installation of high efficiency wood burning cookstoves in Malawi – Project 2” – and the complimentary secondary projects will enable and enhance household level access to sustainable development objectives by distributing, installing, and maintaining fuel-efficient ICSs in Malawi. The project aligns with and will contribute to sustainable development objectives outlined in *Table 1: Summary of SDG Contributions*. Through the distribution and implementation of TLCRS stoves, this grouped project aims to (1) reduce demand for wood fuel, (2) slow local deforestation, (3) reduce the drudgery of collecting wood fuel performed mainly by women and children at significant distances from villages, (4) reduce time spent on cooking over open fires inhaling toxic smoke, (5) increase time spent on improving quality of life i.e., through economic endeavors, education, (6) improve the health status through reduced exposure to household air pollutants (HAPs).

The project is described in several thematic buckets that reflect the sustainable development objectives and impact. The project addresses the key pillars of sustainable development namely, economic well-being, human health and well-being, social equality, and environmental sustainability in the following ways:

	SDG Goal Addressed	Target beneficiary	Impact envisaged through project lifetime
<b>Economic Well Being</b>	SDG 8	Employees hired during various stages of project implementation & operation	50
	SDG 9	Local economy of Malawi	Manufactured parts of ~ 0.5 million ICS
<b>Social Well Being</b>	SDG 2	Group of end users within the project beneficiary population	2000 drip irrigation kits
		Group of end users within the project beneficiary population	268,273 bamboo seedlings
	SDG 3	End user households with focus on women who are primary cooks	~0.25 million households which are expected to experience reduced indoor air pollution.
	SDG 4	Staff receiving non-formal education & training	50
	SDG 5	Women and girls	~0.25 million women who are primarily responsible for fuel wood collection and cooking activities in households

	SDG 7	End user households	0.25 million project beneficiary households who will have access to a clean technology which they would not be able to afford.
<b>Environmental well being</b>	SDG 13	Natural Capital	Avoided emissions to the tune of ~75 tCO <sub>2e</sub> per stove over the 10-year crediting period
	SDG 15	Natural Capital	Avoided removal of ~3.9 tons of woody biomass per stove per year, from forests surrounding the communities.

Each of the SDG Goals achieved through the present project activity are discussed in detail in the following paragraphs-

### 1. Economic Wellbeing

The project will lead to a distribution of 0.5 million energy-efficient ICS throughout its lifetime. Thus, the project will achieve:

- **SDG 8:** Contracting of individuals on full-time and part-time basis with a focus on hiring local people and women (8.3). In the short term, teams of local men and women will be employed and trained to make bricks and build stoves.
- **SDG 9:** Procuring metal parts for ICS being installed under the project undertaken by CQC will contribute to developing resilient infrastructure and sustainable industrialization. The development of this industry will not only contribute to Malawian economy but will also lead to generation of employment opportunities thereby easing to some extent the high unemployment rate in the region and country as whole.

### 2. Social Wellbeing

The project is envisaged to improve the overall social well-being within the project location by yielding human health benefits, increasing awareness levels, reducing gender inequality, and providing access to clean cooking technology to economically weaker sections of the society that does not have affordability and access to this technology. Each of the benefit aligned with respective SDG has been explained in the following points:

The projects will address SDG 2, SDG 3, SDG 4, SDG 5, and SDG 7 in the following ways:

- **SDG 2:** Improved food security for beneficiaries and their families by enabling the adoption of resilient and sustainable agricultural practices among the end-users. The project activity involves distribution of drip irrigation kits to 2000 households which will lead to efficient water management capacitating households to grow crops and vegetables in the dry season as well when water availability is the confining factor for plant growth.
- **SDG 3:** Reduced emission of fine particulate matter (PM<sub>2.5</sub>) resulting in lowering of household air pollution due to use of the TLCRS, improving well-being for women and children (3.0)

Apart from improving health of women, the stoves also reduce severe accidental burns in infants and children due to the use of TLCRS's technology of a closed combustion chamber and stable base

- **SDG 4:** Contribute to increasing vocational and relevant skills of local individuals by introducing them to issues related to climate change, and bring awareness about importance of sustainable development, health, nutrition, and well-being, through formal and informal training which will enhance their avenues for getting decent jobs and employment opportunities (4.4).

The employed individuals will be provided with regular trainings to enhance their vocational skills related to various aspects of project implementation and monitoring which would increase their employability and chances of getting long-term employment even after the completion of the project. Field staff, also known as “health promoters” (HPs) will carry out training work and arrange for stove construction materials. Some of the HPs will be trained to work as ‘enumerators’ and carry out stove registrations, captured through a mobile phone application that sends captured information to an online cloud database.

- **SDG 5:** Reduce women and children’s drudgery by saving time spent in cutting, collecting, and carrying firewood from trees far removed from households as well as reduce time spent in cooking over toxic smoky open fires. These tasks are a major cause of gender inequality in rural communities of Malawi which will be addressed by the project activity and will provide the women folk and children with opportunities to involve in more productive activities (5.4)<sup>4</sup>.

By switching to fuel in small, twig-sized pieces of woody biomass, women, and girls save time collecting, cutting, and carrying heavy wood over long distances. Also, as the CQC TLCRS burns at a higher temperature, with less fuel used, due to combustion chamber and stove design, cooking the day’s meal takes approximately an hour less than it would take to cook the same meal over the TSF. Research by Berkeley Air Monitoring Group<sup>5</sup>, showed two hours a day savings in switching to two stoves per household from the TSF and a meta-analysis of all research into time savings from ICS showed the on average time savings across sub-Saharan Africa to be about one hour per day.

Children, particularly girls, are frequently kept at home to support household chores, like cooking and collecting firewood, estimated on average to be 10 hours per week, with a TLCRS more time can be dedicated to education – attending school and studying<sup>6,7</sup>

- **SDG 7:** The primary activity under the project is distribution of clean cooking project stoves to sections of the Malawian population that are predominantly reliant on wood fuel for meeting their cooking need and are unable to afford improved cookstoves. As clean cooking technology provides an essential tool to addressing energy poverty and ensuring sustainable energy security in approximately 0.25 million Malawian households during the project lifecycle, the project will generate an overall positive impact on the community.

### 3. Environmental Wellbeing

---

<sup>5</sup> Berkeley Air Monitoring Group, 2020.

<sup>5</sup> Berkeley Air Monitoring Group, 2020.

<sup>6</sup> Clean Cooking Alliance, n.d.

<sup>7</sup> Makonese et al., 2017.

The distribution of efficient cookstoves is expected to reduce the fuelwood consumption for cooking purpose which will not only reduce the amount of emissions being released in the atmosphere but also reduce the burden on forest ecosystems in and around the project area. Thus, the project will contribute to SDG 13 and SDG 15 in the following ways:

- **SDG 13:** Each stove is expected to reduce carbon emissions by approximately 3.9tCO<sub>2</sub>e/year effected by reduction in quantity of burning solid fuels combusted for cooking in the household, this does not include black and brown carbon (13.0)
- **SDG 15:** Reduce deforestation and degradation by up to 75 tons, per stove, in the project lifetime (15.3)

Forest, observed as a public place is often used for the collection of fuelwoods, which significantly contributes to deforestation and degradation. The distribution of the TLCRS will reduce fuelwood consumption and hence reduce the pressure on the forests. Due to TLCRSs efficiency and widespread community use, there will be a reduction in firewood cutting from live trees resulting in better management of protected areas.

### 2.1.2 Description of the Project Activity

CQC's ICS project, a low-emission climate-resilient project, was initiated in response to need to reduce greenhouse gas emissions (GHG) to combat the worsening climate crisis that largely impacts the most vulnerable populations residing in sub-Saharan Africa. The focus of the project is on the rural and peri-urban poor who cook on open fires ('three-stone fires' (TSFs)). The project activity is designed to facilitate household-level improvements in cooking amenities and improved health and well-being of women, and children in particular but also with benefits to all members of the household<sup>8</sup>.

The primary activity under this grouped project, is the installation of ICSs. Several secondary activities are also planned under the project activity.

1. **Improved Cookstoves.** The primary project activity is the distribution and installation of the TLC Rocket Stove (TLCRS), a high-efficiency, long-life metal and (made from local material) brick stove that transitions households away from traditional open fire cooking to cleaner, more efficient cooking solutions with renewable biomass fuels. The TLCRS is offered in exchange for in-kind contributions of materials and labor only, as the rural population's disposable cash is limited, and paid positions, where possible, are often informal and operates external to the cash economy.

CQC uses an innovative digital platform to track and manage the ICS project. Education and training of field staff is an important component of project implementation. Using smartphones, CQC and its implementing partners administer various surveys and questionnaires to track project objectives, beneficiary information, and to monitor and evaluate implementation performance.

The associated benefits of this primary activity on local community and ecosystem have been detailed in the section above. Apart from the primary activity, the secondary activities under the Grouped project and their impacts are as follows:

---

<sup>8</sup> Mortimer et al., 2017

2. **Stove Champions Program.** The Stove Champion (SC) program is a unique program under which the most successful enumerators are selected and trained to service 500-1000 households and be in direct communication with their female clients. SC's undertake a minimum of one annual visit post-wet season to each household receiving a stove and ensure repairs are made following storm damage and users follow best practices in stove management upkeep and repair. The key objectives of the SC program are to address any communication deficiencies and reiterate stove benefits and good practice in stove use and maintenance and maximize the benefits of improved stove use and ventilation to women, children, and the environment. SCs are paid on a monthly basis and performance incentives are also considered based on stove built and registered. They also receive a bicycle and phone data allowances to carry out their assigned work.
3. **Bamboo Seedlings.** CQC has distributed 268,273 bamboo seedlings to households with the TLCRS primarily in the Central district, since 2019, and is in the process of following up with these households to check on stove condition and bamboo survival rate. This distribution will continue as a secondary project activity, as an incentive to use and maintain the stoves and to contribute to sustainable firewood supply to project beneficiaries in the near future. CQC plans to provide an additional bamboo seedling to households using their TLCRS every year the stove is maintained and in use. CQC plans to select the most competent women managers of bamboo to provide additional seedlings to enable them to become producers of bamboo firewood for sale.

The bamboo secondary project is amplified by education to households on the benefits of bamboo, training on best practices to plant bamboo, and encouragement to plant bamboo seedlings alongside vegetable gardens for increased nutrition benefits, reduction in time as vegetables and bamboo can be watered simultaneously and can serve as live fencing to protect gardens from roaming animals.

4. **Training.** While training trainers, CQC provides a one-day course on climate change and combustion theory, including impacts of household pollution on health and well-being, as an introductory background to the efficient cookstove intervention. CQC plans to implement training programs that include programs on establishing backyard gardens using drip irrigation kits and bamboo horticulture. Training will generate positive impacts to community groups by enabling community members to build alternative skills and build capacity. Through this training, CQC hopes to provide women the tools and knowledge necessary to become successful entrepreneurs, generate additional household revenue through the sale of produce and bamboo wood. These interventions are expected to advance socio-economic status, generate greater community capacity for sustainable livelihoods, and increase climate resilience.
5. **Activity to support pregnant Women.** Many women in Malawi live far away from the closest healthcare facility. Pregnant women are encouraged to stay at the 'maternal waiting room,' a facility on the hospital/health center premises, a few weeks before their delivery date to ensure they can access healthcare services during the birth of their child. Acting in collaboration with the Area 25 Health Clinic, for each woman who is discharged from the healthcare facility post-delivery, CQC will provide seedlings of high yielding bamboo variety as well as seeds of fruit trees. This will act as an incentive for pregnant women to avail proper healthcare facility during childbirth, which increases the chances of survival of both mother and child as compared to delivery carried out at places not equipped with adequate medical facilities. Additionally, the activity also ensures sustainable fuel supply in near future along with opportunities to earn from sale of products made from bamboo. CQC is also contemplating a double stove per household pilot program in 2,000 households equaling

4,000 stove distributions with plans to expand to all pregnant women receiving care at the Area 25 clinic.

- 6. Domestic Manufacturing Market Development and Support.** Ener-G-Africa (EGA), a Malawian entity formed by CQC (as a minority shareholder) and Malawian entrepreneurs, manufactures all metal stove parts for CQC's Sub-Saharan Africa TLCRS program. Since EGA started manufacturing metal parts for these stoves in January 2020, they have produced more than 300,000 sets of parts. CQC's orders for parts for SSA made in Malawi are for 7 million stoves over 2021-2024. These parts will be manufactured in Malawi, and a large portion will be exported to other countries in which CQC's projects are implemented, generating significant revenues for the entity and its employees.

EGA is a modern manufacturer in the heart of Lilongwe City. Currently, machines include 6 x eccentric presses, ranging from 25 tons to 90 tons with custom-designed dies; CNC automated ring-roller; Servo-Feeder; Automated and Manual decoilers; Auto-feed corrugation machine; Butt Welding Machine; 3 x MIG welders; 8 arc welders and a Surface grinder. EGA's sophisticated production line can produce 6,000 sets of parts in an eight-hour shift, with the capability to operate a 24-hour workload.<sup>9</sup>

EGA is expanding the workforce of skilled labor in Malawi. EGA provides knowledge and skills transfer with the introduction of new technologies, training in advanced manufacturing skills, and good wages and healthcare benefits. In addition, they are currently undergoing ISO 9001 certification for 2021.

- 7. Drip Irrigation Kits.** CQC in partnership with USAID will distribute 2,000 drip irrigation kits to individual households within the next three months. The use of drip kits will enable vegetable production during the dry season, improving the availability of nutritious food and providing a revenue opportunity through the sale of fresh food for greater community-level access.

The secondary projects of CQCs work in Malawi as detailed above, with the primary project being TLCRS implementation, contribute to the overall SDG benefits of this grouped project. The project design cycle for the TLCRS is illustrated in image 1.

---

<sup>9</sup> Ener-G-Africa TLC Rocket Stove Mini Documentary in combination with C-Quest Capital: <https://www.youtube.com/watch?v=0oDBDytJPT0>

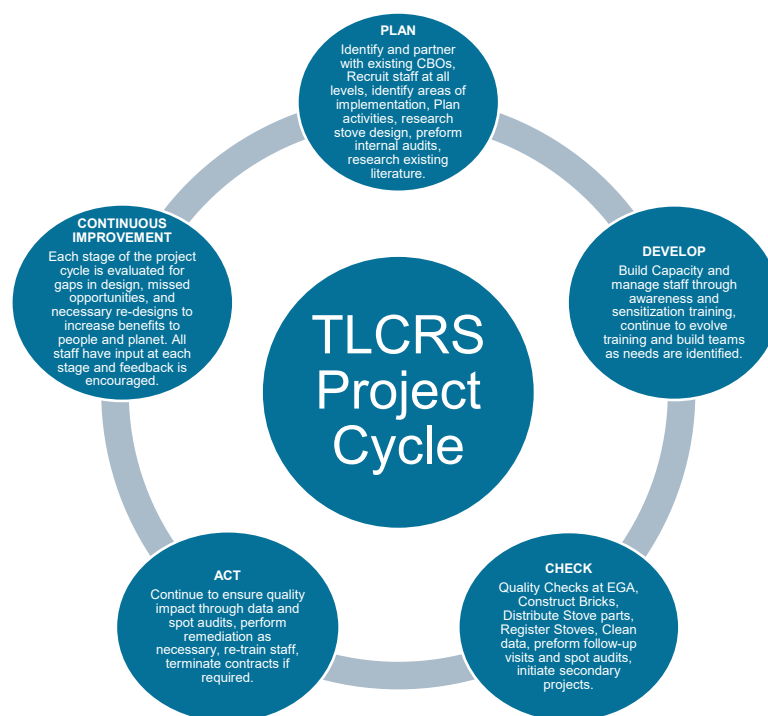

Image 1: TLCRS Project Cycle

### 2.1.3 Implementation Schedule

Date	Milestone(s) in the Project's Development and Implementation
05 July 2020	Project Start date: Project Activities commence with TLCRS installations
23 August 2021	Listing of VCS PD on VERRA
12 December 2021	Registration of project under VCS
09 July 2021 to 21 July 2021	VCS Monitoring for MP 5 <sup>th</sup> July 2020 to 15 <sup>th</sup> April 2021
09 July 2021 to 21 July 2021	SD VISTA Monitoring for MP 5 <sup>th</sup> July 2020 to 15 <sup>th</sup> April 2021
15 July 2021	CQC submits the projects documents to VERRA for listing under SD VISTA
14 September 2021	Commencement of validation for SD VISTA
02 March 2022	First issuance of VCU's received under VCS project
07 January 2022	Positive Validation opinion for the project received from the VVB
10 February 2022	Submission of project documents to VERRA for SD VISTA project registration
05 July 2020 to 04 July 2030	Concurrent monitoring and evaluation

04 July 2030	The 10-year project validation period concludes with a projected 0.5 million stoves installed.
--------------	--

#### 2.1.4 Project Proponent

<b>Organization Name</b>	C-Quest Capital Stoves Asia Limited
<b>Role in the Project</b>	Project Proponent
<b>Contact Person</b>	Ken Newcombe
<b>Title</b>	Director
<b>Address</b>	Brumby Centre, Lot 42, Jalan Muhibbah, 87000 Labuan, Malaysia
<b>Telephone</b>	1 (240) 491-2650 +6 087 42828
<b>Email</b>	<a href="mailto:Cqc-operations@cquestcapital.com">Cqc-operations@cquestcapital.com</a>

#### 2.1.5 Other Entities Involved in the Project

No other entity is involved with the CQC TLCRS Project.

#### 2.1.6 Project Type

This is a non-AFOLU (agriculture, forestry, and other land use) grouped project with general sector contributions identified in the chart below, primarily energy efficiency.

Sustainable Development Verified Impact Standard Sectoral Scopes	U.N. Sustainable Development Goals
<b>Sectoral Scope 2 - Climate Change Adaptation</b>	Climate Action 13.0 Life on Land 15.3
<b>Sectoral Scope 3 - Education</b>	Vocational Training for All 4.3
<b>Sectoral Scope 4 - Energy</b>	Affordable energy 7.1
<b>Sectoral Scope 5 - Food</b>	Sustainable Food Production 2.4
<b>Sectoral Scope 7 - Health</b>	Good Health and Wellbeing 3.9
<b>Sectoral Scope 10 - Livelihoods</b>	Decent Work and Economic Growth 8.3 Reduced Inequalities 10.2 Resilient Infrastructure, Promote Inclusive, and Sustainable Industrialization 9.3
<b>Sectoral Scope 14 – Women's Empowerment</b>	Gender Equality 5.4

#### 2.1.7 Project Location

The ICS project and secondary project locations will take place in the geographic boundaries of the Republic of Malawi with geographic coordinates 13°15'15.5" S latitude and 34°18.091' E longitude.<sup>10</sup>

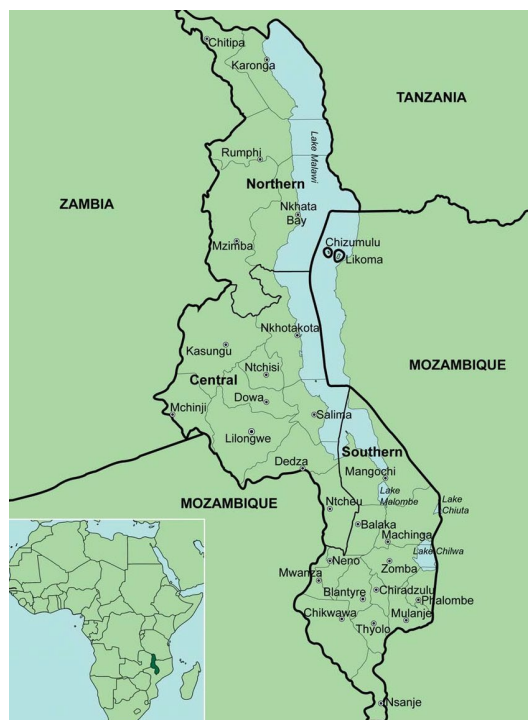

### 2.1.8 Baseline Scenario

Before project initiation, households, almost exclusively apart from urban high-income households, in Malawi use traditional three-stove fires common to much of sub-Saharan Africa. The open fire (TSF) used by the target population requires large diameter logs, commonly procured from nearby non-renewable live biomass sources (firewood) found on forest patches or growing on/near farmland. As population growth and density have increased, demand for large diameter wood for three-stone open fires has led to intensified deforestation and land degradation and an increasing amount of time spent by women and girls, collecting firewood further and further away from their village communities.

Malawi is a land-locked country in southern Africa where the main economy is small-scale, rainfed subsistent traditional agriculture practices<sup>11</sup>. Over 85% of the population of Malawi is involved in smallholder farming, with women representing over 80% of this labour force.<sup>12</sup> With 83% of Malawians living in rural areas<sup>13</sup> and 91% relying on firewood for cooking.<sup>14</sup> The households that rely on firewood cook primarily on smoky inefficient three-stone fires using

<sup>10</sup> [Malawi Geographic coordinates - Latitude & longitude \(geodatos.net\)](https://geodatos.net)

<sup>11</sup> Parrish et al., 2020

<sup>12</sup> Hyder and Behrman, 2014

<sup>13</sup> World Bank, Rural Population (% of total population) – Malawi: <https://data.worldbank.org/indicator/SP.RUR.TOTL.ZS?locations=MW>

<sup>14</sup> World Health Organization data from 2019, updated June 07, 2021 states that 1.9% of the population of Malawi rely primarily on clean fuels and technologies for cooking: <https://www.who.int/data/gho/data/themes/air-pollution/household-air-pollution>

large-diameter branches and/or wood logs collected through unsustainable non-renewable processes from trees existing on surrounding farmland and forests.

### 2.1.9 Causal Chain(s)

See appendix A for the Causal Chain image.

### 2.1.10 Threats to the Project

#### **Human-Induced Threats**

Threat: Stove users' lack of upkeep of stove resulting in either malfunctioning of the stove as designed or lack of stove use.

Solution: CQC conducts routine spot audits early in the process of construction of stoves in each main geographic focus for mass stove installation to detect defects in stove construction, maintenance, and sub-optimal stove use. CQC requires its Implementing Partners (IPs) to hire, train, and supervise stove builders and users, including Stove Champions, to visit each household to inspect their stoves, up to 2 times per year. This dramatically reduces the threat listed above. Additionally, CQC contracts independent third-party auditors or local CQC staff to perform spot checks or sample size reviews to identify lapses in stove upkeep. Upon receiving these reports CQC contracts sub-proponents, called Stove Champions, to perform follow-up visits to households to provide additional education and encourage stove upkeep and use.

Where metal parts of ICS's commonly found on the market are made of low-grade steel, CQC has upgraded the metal parts for the TLCRS are made of higher-grade heat resistant steels, determined by extensive stress testing by Colorado State University, USA, to have a lifespan of a minimum of 10 years. Metal parts include a fuel shelf that doubles as a brick mould, pot skirt, and stovetop.

Threat: Failure of Behavior Change resulting in high levels of non-adoption

Solution: CQC continuously researches the impacts of behaviour change for successful adoption. Study outcomes, whether formal or informal, are included in future training and community sensitizations to continue to positively, shape knowledge, enhance positive peer-to-peer influence, and increase women's sense of empowerment feeding into social cognitive theory on identity and self-belief. Non-adopters and non-implementors are specifically engaged to understand the barriers to success, these outcomes and conclusions are included in future training and disinformation is countered through community sensitization.

Threat: Carbon-financed stove distribution is not shown to have an increased impact on household uptake.

Solution: While research suggests that providing a subsidized ICS to the household does not have a positive impact on successful adoption (owing to lack of perception of value of the stove), there is enough evidence on other hand to show, knowledge of time saving and awareness of the correlation between health benefits and reduced smoke improves adoption rates. Although CQCs ICS provided to households is subsidized, training highlights time savings and increase health benefits (decreases in acute respiratory illness for mothers and children, decreased morbidity/mortality from HAP, and increased nutrition status through

retention of nutrients due to more uniform cooking), as well as previous users reasons for adoption (cleanliness of pots, increased social standing, appearance, safety, less smoke). Awareness of the later impacts of ICS cooking is used to counter the threat.

Threat: Envisaged lobbying by fuel vendors to restrict communities from switching to project cookstoves as they might experience a loss in their income levels

Solution: This threat is not of practical significance as according to the DHS survey 2018, 91% of rural population in Malawi relied on wood fuel as primary source of cooking fuel while the national average stood at 80.9%. With majority of people depending on wood for cooking it is unlikely that the reduction in demand for wood within project boundary would greatly impact the stakeholders involved in selling wood. So, any reduction in demand for wood fuel within project boundary will shift the stakeholders selling wood to outside project boundary, without causing significant reduction in their business as there would still exist a considerable demand for the product.

### **Nature-Induced Threats**

Threat: Climate Crisis induced displacement/migration (shock-related drought or flood) causing households to change location

Solution: Although the ICS installed under the project are fixed type of stoves, however, the main body which consists of bricks made of commonly found local elements (5L each of clay, sand, dung, and water) can be easily reconstructed whereas the steel parts can be easily removed and used again in newly constructed stoves. This technology can travel easily with the household in their migration and can be rebuilt at a new location using the steel brick mould which is provided to each end user at the time of stove installation. The end user is also provided with the knowledge and requisite training on construction of the bricks as well as stove assembly should the need arise for them to reconstruct the stoves.

Threat: Continued deforestation and degradation making firewood an untenable source of biomass.

Solution: Although increased scarcity would support the use of the TLCRS, there is the potential that as the population continues to expand, particularly on the African Continent, there may be a point when firewood becomes an untenable source. Although access to modern fuels may not be physically or financially accessible to ICS households in the future, creating more dependence on biomass cooking. CQC trains on the use of small branches and twigs, and use of crop residues such as maize cobs and provides households with bamboo seedlings for a fast-growth close-to-home source of regenerative biomass. Where possible, CQC will advocate for policy changes and the inclusion of regenerative forestry in governments' low-carbon action plans to support forest protection and regenerative woodlots for sustainable consumption.

### **2.1.11 Benefit Permanence**

To ensure the ICS project's long-term viability and the permanence of ICS and other program benefits, CQC has committed to the following long-term aims:

- (1) A manufacturing unit EGA, was established in Malawi where the three metal parts of each stove are built, this will continue throughout the project lifecycle. The local stove

production will benefit the local economy as EGA offers job opportunities to Malawians, which continues to build the knowledge and skills for long-term inclusion in the formal sector of the national economy.

- (2) Implementation and spot audit teams will be hired and provided with transportation and smart mobile phones that meet the physical mobility and remote connection requirements of the positions. Transportation provided includes bicycles, motorbikes, or motor vehicles, depending on the position. For Stove Champions and Health Promoters who may work on a part-time basis, bicycles remain with staff members, contributing to year-round physical mobility that reduces time spent traveling by foot, increases access to local markets to sell income-generating products, and provides reliable access to local health facilities; overall, acting as a catalyst for upward economic well-being. This is a long-term commitment.
- (3) CQC is working to make the TLCRS available to all households through the purchase of CQC's 'Stove-in-a-box' kits. This provides the metal components of the ICS and directions on assembling the brick structure that houses the metal components. This 'Stove-in-a-box' program does not replace the projects outlined in section 2.1.2, rather it offers the stove to a section of end users which are not the target beneficiaries of the project – maintaining long-term benefits to Malawi. EGA with CQC's support plans to set up a distribution program for 'Stove-in-a-box' throughout Malawi, increasing availability of clean cooking technology along with other basic goods to rural families.
- (4) Through CQC training of stove champions, health promoters, communities, and continued individualized education support and training directly to households, CQC provides holistic, long-term environmental, health, nutrition-sensitive awareness, and community resiliency awareness to advance the benefits to stakeholders and maintain project activities and intended outcomes.

Moreover, CQC plans to continue activities until potential beneficiaries have been exhausted and remain committed to the continued improvement of rural livelihoods.

## 2.2 Stakeholder Engagement

### 2.2.1 Stakeholder Identification

A three-step approach is adopted by CQC for identifying the relevant stakeholders associated with the project throughout its lifetime. The following figure describes the approach adopted for stakeholder identification:

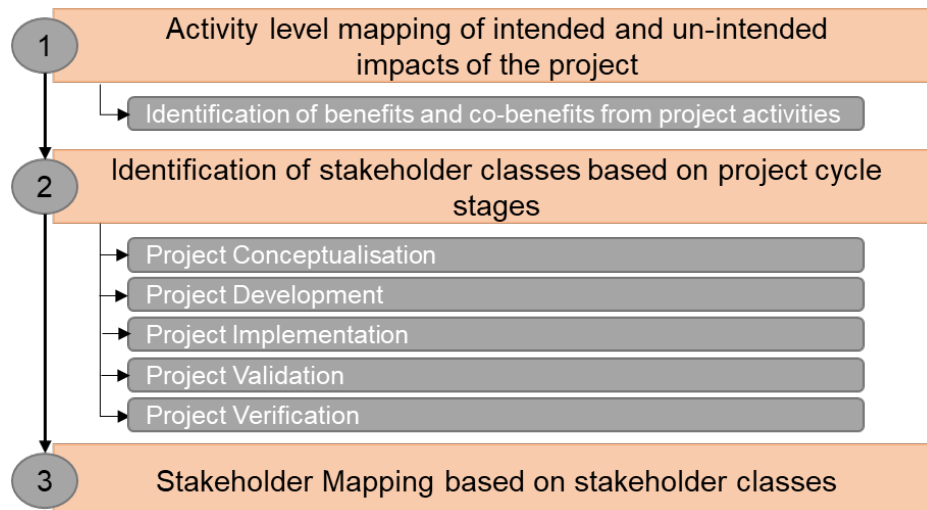

The first step involves identification of intended and un-intended impacts associated with the project activities. Once the impacts are identified, probable stakeholders affected by these impacts were mapped.

After developing a holistic outlook about the overall benefits and co-benefits of the project; stage level stakeholder group identification is undertaken. The different phases considered for stakeholder identification are

- *Project conceptualization*- stakeholders would include self-help groups, academia, local community representatives residing within area of project implementation and therefore can help the project promoter make ingress within the community etc.
- *Project Development*- government representatives, community development groups, investors, employable youth, NGOs working in similar sector etc. would be the stakeholders at this stage.
- *Project implementation*- end users, implementing partners, stove part manufacturers etc. would comprise of the stakeholders during implementation.
- *Project monitoring*- surveyors, database developers etc could be some of the main stakeholders during project monitoring.

At the end of second step different groups of stakeholders affected during different stages of project development will be identified.

For convenience of engaging different stakeholder groups and obtain their response, CQC generally identifies stakeholders under two broad classes: directly affected parties and indirectly affected parties. A detailed description of these classes is defined in section 2.2.2.

The final step includes stakeholder mapping and identification of representative individuals from each stakeholder class identified in step 2. Focus is kept on identifying stakeholders within each of the following categories: end users, government organizations, international government agencies, non-governmental organizations, religious aid agencies, academic, current, and potential future implementing partners, stove manufactures, carbon sector organizations, partner donors, the media, and individuals, and their families. Specific focus

is made to include individuals and groups who may be directly or indirectly adversely affected by project activities.

## 2.2.2 Stakeholder Description

The stakeholders identified through the process described in section 2.2.1 above are generally grouped under two broad categories as represented in the figure below:

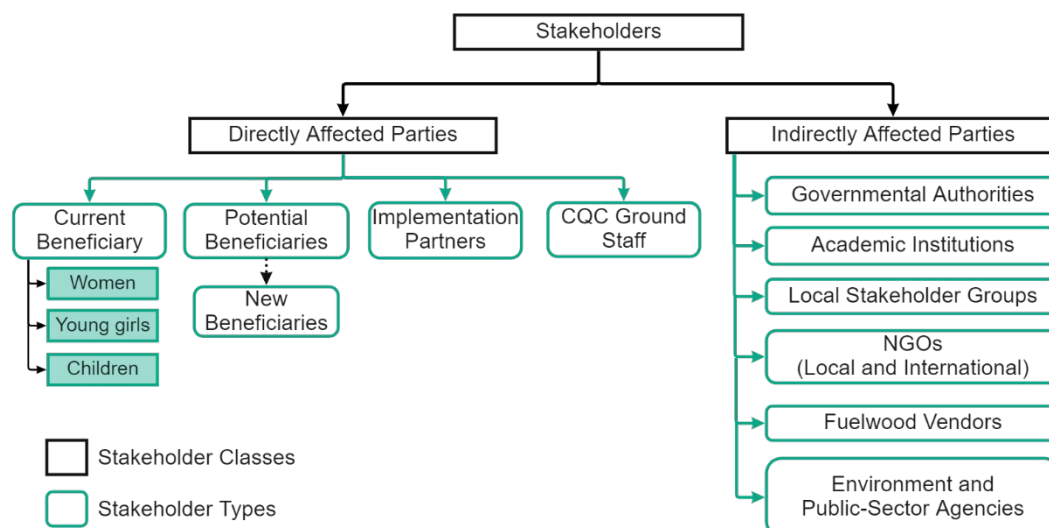

### Directly Affected Parties

(1) Current Beneficiaries: TLCRS registered users and other family members within the serviced households

Beneficiaries are identified as an individual, primarily women as the cook in the household, who is willing to adopt a climate transformation technology, i.e., the TLCRS. Beneficiary families are those living in or sharing the same family compound as project beneficiaries. No hierarchy of priority is established to determine who receives an ICS sooner rather than later. Each household demonstrates interest and provides in-kind contributions to build the stove exterior. There is occasionally a delay between an individual and the household that expresses the desire to have a stove and the stove implementation due to availability of metal parts and implementing partner workloads, however, CQC provides an ICS to each household in Malawi that expresses the desire to adopt the technology. Beneficiaries that adopt the TLCRS are eligible to benefit from the secondary projects and benefit from the SDGs identified in chart 1.

(2) Potential Beneficiaries: new users and potential adopters

CQC actively seeks out new beneficiaries, through sensitization events, active communication with traditional authority leadership and influential authorities and traditional leaders, and promoting the TLCRS at local community gatherings, i.e., markets and health clinics. CQC seeks out partnerships to expand the climate transformation technology to those that use the three-stone open fire and are particularly vulnerable populations. An example of such a partnership is the relationship with Area 25 Health Centre where CQC provides the TLCRS to pregnant women supporting their health and nutrition status from early stages in

pregnancy with the intent to have a multiplying effect on their infant children and other young children in the household.

The current and potential beneficiaries typically share similar characteristics within Malawi as our current target demographics are individuals and households in rural settings, although there are plans to expand into the peri-urban and urban settings to offer the TLCRS to any individual prepared to adopt its technologies. This plan is designed to drastically reduce the need to use the three-stone cookstoves. CQC provides all households with a double stove, which consists of two sets of metal parts and two individual brick constructions attached with two bricks at floor level to eliminate the use of the three-stone cookstove for cooking use.

(3) Implementing Partners: Organizations in partnership with CQC

CQC operates the TLCRS program and any secondary projects through various implementing partners. Partners are traditionally well-established organizations with community networks and knowledge of local customs which gives them an extra edge in implementing the project as communities are familiar with their presence. The implementing partners are directly benefited through knowledge, employment, and monetary gains incurred due to project implementation.

(4) CQC on-ground staff:

C Quest Capital employs local manpower during various stages of project development and implementation to carry out its developmental activities in host countries. These individuals benefit not only from immediate employment in the organization but also through various training programmes throughout the project life thereby improving their overall chances of employment.

**Indirectly Affected Parties**

(1) Governmental Authorities: CQC and implementing partners engage with local traditional authorities through 'Courtesy Calls' to provide information and gain input on the anticipated projects. CQC teams gain permission from the local Traditional Authorities to operate in these areas through these 'Courtesy Calls;'

(2) Environment, Health, and Nutrition public-sector agencies: In-country agencies that work in tandem with CQC's projects through implementation, operate in the same geographical areas, or operate their projects that may touch upon similar sectors as the projects CQC implements;

(3) Academic Institutions: CQC is invested in partnerships, providing funds, and welcoming interested academic institutions to study our projects at any level but particular interest to us is through direct household-level studies of beneficiaries so that CQC can best understand the impacts, positive and negative, how to magnify the positive and eliminate or reduce the negative impacts. CQC currently has relationships with academic partners at Duke University, Lilongwe University, and Oregon State University, and various contracts through other high-ranking academic institutions.

(4) Local and International NGOs: In-country partners that work in tandem with CQC's projects through implementation, operate in the same geographical areas, or operate their projects that may touch upon similar sectors as the projects CQC implements.

(5) Others, as applicable and interested: CQC welcomes feedback and interest in our projects from interested sources that may not have been identified in this description. However, CQC reserves the right to act upon feedback and correspond with the party providing feedback to ensure it originates from a constructive source.

### 2.2.3 Stakeholder Consultation

CQC is committed to continuing consultations with stakeholders to ensure project activities include the identified benefits as they correspond to the Sustainable Development Goals. CQC underwent a local stakeholder consultation (LSC) parallelly with VERRA/Voluntary Carbon Standard (VCS) process between 26 October to 25 November 2020, CQC will re-engage the stakeholders that participated in the feedback for VCS and seek new stakeholders that may have not been included, with a focus on underrepresented, women, and marginalized populations, due to the non-grouped nature of the VCS. The LCS for the SD Vista process will be executed similar to that of the VCS process, with additional requirements of the SD Vista continuous engagement of stakeholders.

For the VCS, the LSC sought feedback virtually, due to the ongoing Covid-19 pandemic, through feedback forms on CQC's website, direct email, and phone calls, with in-person meetings occurring with individuals and groups of current beneficiaries following appropriate covid related protocols. A newspaper advertisement was placed in 'THE NATION', Malawi's leading daily newspaper, announcing the LSC. The following chart provides information on how CQC will conduct stakeholder consultations for the SD Vista application.

Stakeholder Group	Identified Stakeholder (continuously expanding)	Consultation Activities
Directly Affected Parties	Current Beneficiaries (individual, household, and community level)	-Community Level Sensitization Activities -Open Communication with implementing partner and CQC Direct -Household Stove Champion Visits/ Surveys -Methods may vary to provide consultations that mean the needs of the community/household.
	Potential Beneficiaries and Community Groups (individual, household, and community level)	-Community Level Sensitization Activities -Open Communication with implementing partner and CQC Direct -Household Stove Champion Visits/ Surveys -Methods may vary to provide consultations that mean the needs of the community/household.
	Implementing Partners	-Open Communication with CQC -Training on Impacts of TLCRS and secondary project activities
	CQC on-ground staff	-Training on Impacts of TLCRS and secondary project activities
Indirectly Affected Parties	Governmental Authorities, Environment, Health and Nutrition public-sector agencies, Academic	-Published announcement of continuous stakeholder feedback – CQC website, and other media as appropriate. -Online, Email and Phone Distanced Feedback options

	Institutions, Local and International NGOs, Media, and Others as applicable	-CQC’s Social Media Communication and Updates -Research Collaboration (academic, others (as applicable))
--	---	---

CQC Implementing Partners engage with beneficiaries and their families several times over the year through household visits. During these visits, education and maintenance are consistently reinforced to the household, with hands-on technical assistance, if necessary, by the Stove Champions. During the initial community sensitization and training by Implementing Partners, the benefits of the primary project and secondary projects are detailed to community members. Educational materials (brochures) are distributed to potential beneficiaries.

During the CQC Verra LSC, Indirectly Affected Parties were approached virtually (email, phone calls, website collection forms) and Affected Parties were approached in-person. CQC has retained the stakeholder lists as well as the feedback sent during the VCS LSC. For SD VISTA CQC will re-approach all identified stakeholders as well as potentially impacted stakeholders to match the defining parameter for SD VISTA. Identified stakeholders will be contacted through virtual means, informed about the SD VISTA Programme and the identified sustainable development initiatives along with project details, and feedback will be collected and evaluated to determine if project designs should be altered to magnify positive impacts. Stakeholders will also be encouraged to provide public comment during the VERRA public comment period. To maintain continuous stakeholder communication, CQC will make a permanent feedback section on our website and seek feedback.

For Directly Affected Parties, CQC will collect feedback through the Stove Champions or Spot Audit survey. During the LSC that was conducted for the Verra project, the following feedback was received which also corresponds with the SD Vista application and identified benefits to people and the planet:

*Female beneficiaries of the project greatly appreciated the lack of smoke on the CQC stove compared to open fires and the stove has increased their time for other social/economic activities by allowing them to cook with fewer sticks. They also indicated that the pot skirt helps keep their pot cleaner and retain heat, thus allowing fast cooking. In conclusion, participants widely recognized the benefits of the stove programs already active in Malawi and look forward to seeing how the reach and impact will be expanded on and how the lives of the people living there will be changed in the years ahead.*

One concern that was mentioned by the female beneficiaries during LSC was that, initial cooking took a bit longer, mostly when using a bigger pot as many households have bigger families. As such, CQC has added a second stove to support the elimination of the TSF and continues to decrease the amount of time it takes to cook as most meals are prepared in two pots. This is one example of how CQC is committed to project evolution through stakeholder comments.

Local stakeholder involvement will be continuous and evolutions or adaptations to the project will occur to amplify the benefits of the projects to the planet and people.

## 2.2.4 Continued Consultation and Adaptive Management

Consultation and Adaptive Management will continue throughout the project lifetime as CQC is committed to project evolution to best meet the needs of the beneficiaries and amplify, where possible, the impact of the project activities as they related to the SDGs. CQC is also committed to additional projects, where feasible, that multiply sustainable development and enhance the empowerment of women, child and household nutrition, health, and economic wellbeing.

CQC collects input from beneficiaries through touchpoints over a year, up to 5 times (see section 3.3 for more details). Interactions range from informal consultation discussions to more formal surveys with specific questions on use and adoption. Some of the visits are conducted by stove champions that inquire about likes, dislikes, adoption rates, benefits that CQC may not have identified, and unidentified challenges for the cook. Other visits are conducted as audits through CQC's compliance teams in-country or CQC operation staff.

Since the origination of the TLCRS, CQC has adapted the TLCRS as follows:

- Beneficiaries showed evidence of using the three-stone cookfire in addition to the TLCRS, which was identified through CQC audits and follow-up visits, as such, CQC added a second stove to each household with the intent to further reduce the use of a three-stone cookstove. The second stove allows the cook to cook both traditional sauces and grains simultaneously, further reducing the length of time it takes to cook the meals and increasing the time saved. Additional benefits can be seen in increased nutrition retention and health benefits through reduced PM<sub>2.5</sub> and burn risk for children and infants in the kitchen.
- Academic research has shown that beneficiary' and potential beneficiary' knowledge of climate change and the reduction of emissions using an ICS does not equate to increased adoption rates. The relationship between climate change and greenhouse gas reductions through the TLCRS will continue as part of the sensitization and community-based training, however, additional topics on the benefits of TLCRS's use to the health and nutrition status of the household members will be included in the training, as research demonstrates there is a stronger association to these two topics and increased adoption rates.

CQC encourages continuous improvements through input from stakeholders, specifically the academy, beneficiaries, and potential beneficiaries. CQC seeks continued consultation and practices adaptive management to provide the best products and sustainable development outcomes to our beneficiaries.

## 2.2.5 Anti-Discrimination

CQC is committed to providing the best possible climate for maximum development and goal achievement for all its employees and contractors. CQC believes that discrimination in all its forms (gender, race, religion, sexual orientation, or other habits) and sexual harassment and assault have no place within the development sector and more specifically at CQC, our implementing partners, our employees, contractors, and third-party individuals, and within the

projects we design, fund, and execute. Specifically, our project activities are designed to reduce or eliminate, where culturally possible, discrimination, sexual harassment, and sexual assault where it exists within the societies where we work.

CQC supports diversity, inclusion, and equity with attention to vulnerable populations, including women and female children. CQC prohibits any form of discrimination, harassment, or assault, all being grounds for dismissal of employment, termination of the contract, an immediate discreet investigation of the reported incident, and where warranted, report to the applicable authorities.

CQC abides by the labor laws in the countries where we operate and contract individuals, the project proponent, and implementing partners welcome any beneficiary who requests our project services and is committed to the stated terms and conditions of project participation.

The present project provides equal opportunities for all eligible individuals. Both local men and women have been employed in managerial roles to oversee the implementation, operation, and maintenance of project in the target community. In addition to the fact that the project does not differentiate on the basis of gender, culture or race, the project promoters have taken extra efforts towards improving gender parity by employing women as stove champions who function as the management’s last mile connection with the end users. It is these women who visit households and encourage end users to continue using project stoves by describing the various benefits that its use brings about in the household and the immediate environment. As expected, this effort has paid off for the said project since drop off rates observed are negligible.

Apart from providing equal opportunities to all, the project proponent has established standard procedures to ensure employees, whether temporary or permanent, can at any time report any incidence of discrimination or biases. The following diagram represents the overview of anti-discrimination policy followed by the project proponent.

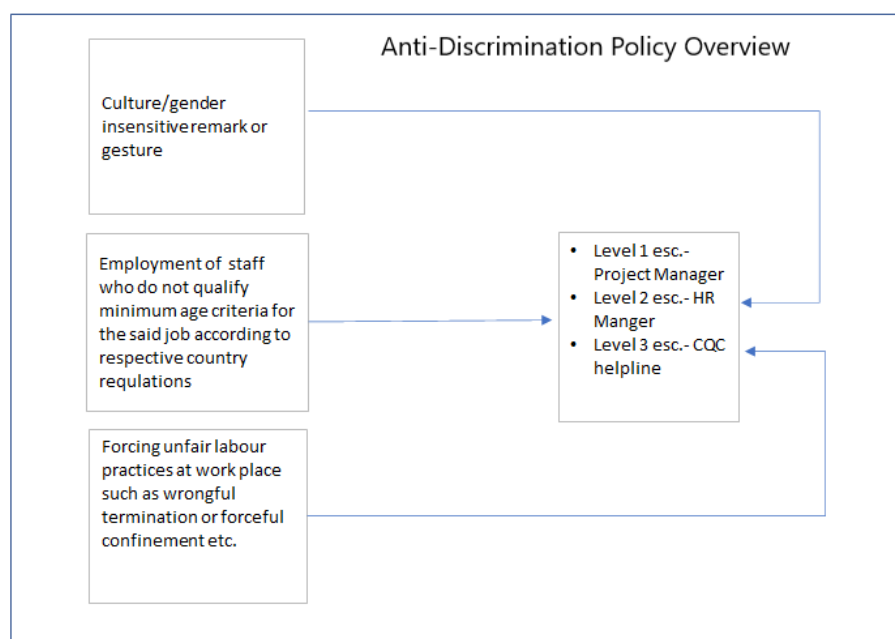

## 2.2.6 Worker Training

CQC understands that a new job is exciting and at times can be overwhelming. CQC has teams worldwide, U.S.A., Australia, India, Malaysia, and in-country teams in locations where our projects are implemented. CQC and its affiliates understand the importance of employee and contractor contribution and providing the finest quality services to our clients, our reputation and continued expansion of benefits depend on client satisfaction which is connected to our employees and contractors.

CQC provides a detailed employee handbook. It details (i) the way CQC works, (ii) pay and progress, (iii) time away from work and other benefits, (iv) on the job conduct, (v) data security, (vi) safety in the workplace, (vii) anticorruption, antibribery, and anti-terrorism procedures, among other elements.

Independent Contractors are contracted through the CQC and the contract reflects the workers have trained in the U.S.A. anticorruption laws before the start of their employment and contracting. CQC provides training to country managers and other team managers, as appropriate, once these individuals are trained, they are responsible for providing standardized and regularly revised training and guidance to the teams they oversee and are trained by CQC in a train-the-trainer model. The contractors are also responsible for providing training to the household's primary cooks in construction, maintenance, and best practices in using the TLCRS before the registration of the stove.

The training that is provided to the independent contracts by CQC is a two-day extensive training with 'in-the-classroom' education and the second day of on-the-ground training. The agenda topics for day one include: Review of the Program, information about CQC, The process, the purpose of the training, expectations, roles and responsibilities, basics of climate change, the impact of traditional fires, heat science, Details of the Stove, Registration & Verification. The agenda topics for day two include: time to travel to-from the village for stove implementation, group building of stoves, discussion of maintenance of stoves, construction of stoves in smaller groups, and wrap-up.

Training materials are in flux as CQC makes edits to the stove design or other identified areas where the training needs to be redesigned.

Topics in the training that relates to the SDGs include education on climate change, health, and nutrition benefits of stove adoption, while having the double benefit of educating implementors on these topics, so they can engage in educated decisions in their day-to-day lives. The first day of training involves the description and visualization (PowerPoint) of how to construct the stove and the second day of training is when the project's workers are trained directly in villages on how to construct the stove. The coverage and hands-on training build locally useful skills and knowledge to increase local participation in project implementation. These trained trainers go on to provide sensitization campaigns and training of each beneficiary, so the benefits are amplified.

### 2.2.7 Equal Work Opportunities

CQC makes every effort to abide by the laws and regulations of the countries we operate in, as well as, US law, and international statutes, as applicable. When conducting recruitment, CQC prioritizes hiring local community members and offers new opportunities to project beneficiaries as CQC expands operations and job openings arise.

This priority demonstrates CQC’s reverence for the deep understanding of cultural nuances that only local community members could hold and this quality in addition to the ability to take initiative and work independently are primary qualifications CQC seeks in candidates. CQC also seeks to mirror the percentage of women/men in the country in its in-country workforce, making all efforts to hire women candidates for all levels of positions.

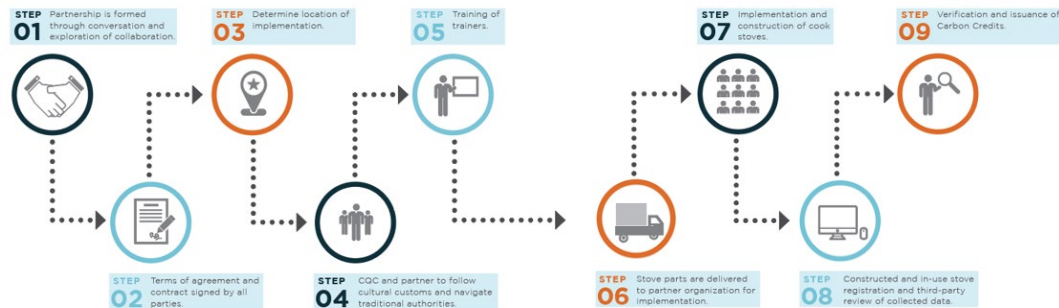

*Image 3: Steps of Project Cycle that include identification of equal work opportunities, partnerships, and training.*

## 2.2.8 Workers' Rights

The contractor, synonymous with implementing partner, enters into an independent contractor agreement with CQC. The agreement contains details of CQC’s and the contractor’s compliance with laws including, national, sub-national, state, and local, as well as policies, laws, rules, and regulations, including the United States Foreign Corrupt Practices Act. Specific information is provided on anti-terrorism and anti-corruption efforts, including a code of conduct.

Per the Core Labour Conventions of the International Labour Organisation (ILO), CQC, respects, and works in tandem with the elimination of all forms of forced or compulsory labour, the effective abolition of child labour, minimum age convention, the right to organize, and the elimination of discrimination in respect of paid positions and occupation.

## 2.2.9 Occupational Safety Assessment

To mitigate the rare yet potential occupational safety hazards, CQC makes every effort to contract workers who have lived in the community for several years, this assists in mitigating the occupational hazards through community familiarity, language fluency, and native to the culture. This understanding of traditional values, respect, and working environment in the communities CQC serves, support reduction of safety hazards. CQC provides Group Personal Accident insurance to our office staff.

Occupational Safety Hazards that have been identified are transport-related accidents, theft of parts, corruption, and jealousy of CQC contractors by their community counterparts. Transport-related accidents involve vehicle, motorbike, and bicycle accidents. CQC provides these modes of transportation to their contracts where necessary. Ultimately, the infrastructure conditions, whether through road constructions or road disturbances (loose animals, poor weather, i.e., rain) cause hazards that are not specific only to CQC but a hazard existing country wide. Other hazards include theft of parts which has been mitigated by the collection of parts by a health promoter.

Risks are assessed and mitigated where possible and workers, stakeholders, and others directly involved with the projects are made aware of the potential risks and opportunities to mitigate where possible, yet it should be noted that paid positions or use of the stove do not increase the safety risks that are already present in the landscape of the country.

### 2.2.10 Feedback and Grievance Redress Procedure

CQC's Feedback and Grievance Redress Policy and Procedure ensures that project-affected communities and individual grievances are properly prioritized and addressed. These measures are taken to enhance CQC's accountability and transparency and to support the project initiatives should the community identify adverse effects to them, their communities, or their environment that has not been previously identified and mitigated by CQC. The full grievance redress policy and the procedure is available upon request and detailed in short below:

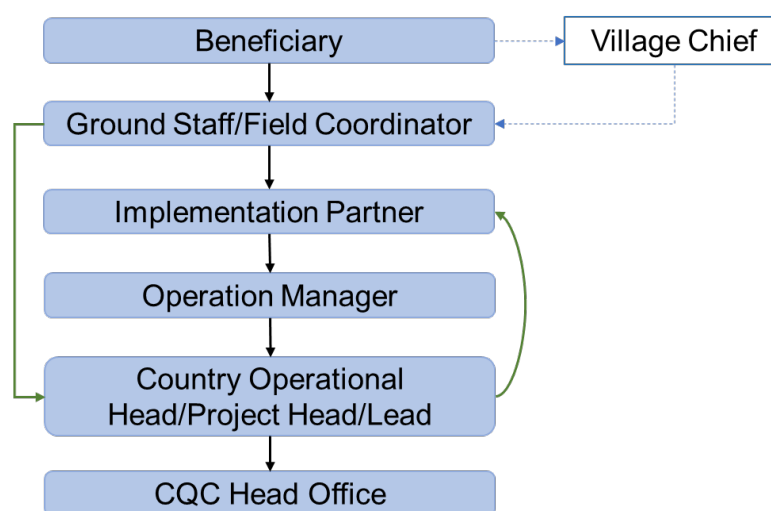

The first step of a complaint is typically applied to the informal procedure, where the affected person discusses the identified issue or provides feedback with the Field Coordinator or another member of the management team. In case the end-users are not very comfortable in approaching CQC team directly, a provision is made for them to approach us through their village chief. The village chief then reports the concerns to the concerned person, i.e., field staff from CQC who takes it further and resolves the issue. This is undertaken to protect the traditional sentiments and value system of the villages and help them express their issues without any hesitation. The Field Coordinator attempts to resolve the grievance immediately on an informal basis, seeking advice from other parties (Area Development Committee, etc.) where necessary. The Field Coordinator and affected person work together to as immediately as possible, solve the identified issue. This informal procedure does not prevent an individual or community from the formal complaint process at any time.

The formal process requires the grievance to be filled in a written form, with the form available at the TA's office and collected by the CQC Field Coordinator. If literacy is a barrier, or other barriers exist such as distance to the TA's office, a telephone call to the CQC Direct office in Lilongwe is recommended where the grievance will be captured and recorded in written form

by a staff member at the office. The CQC Direct office number is available to all project beneficiaries on brochures and posters provided at registration and during community sensitization.

All grievances are to be assessed and an update is provided to the grievant within 10 days. Three options for procedure guide CQC Direct's response (a) resolution is offered immediately according to the request made by the grievant; (b) resolution is more complex and requires additional consideration or extraordinary resources will lead to the grievant invited to a meeting to discuss options; and (c) where the complaint cannot be resolved through a meeting an investigation is arranged within 1 week (7 days) to gather additional information, led by the Field Coordinator, followed by a grievance hearing within 10 working days of the completed investigation.

Formal grievances are recorded in summary and shared with CQC to identify if the complaint is a project-wide issue that necessitates a system change in implementation.

### 2.2.11 Feedback and Grievance Redress Procedure Accessibility

The CQC Grievance Policy and Procedure is accessible as the phone number of CQC office in Malawi is available on the brochure provided to each household, which is the most accessible manner to provide feedback. CQC policy and procedure outlines the process to evaluate and respond to complaints; the procedure details when a serious level complaint should be communicated to CQC country teams and when it would be best addressed by the implementing partner. Additionally, the grievance policy and procedure are verbally described during courtesy calls to TA's and the Area Development Committee (ADC).

### 2.2.12 Stakeholder Access to Project Documentation

A hard copy of all the project related documents is maintained with CQC IPs and central office in the host country which is accessible to all the stakeholders associated with the project, especially end-users. Considering that the project documents are very technical and will be difficult for the end-users to comprehend, a non-technical summary detailing the project activities and its outcomes is also available with IPs as well as central office in the host country. During the distribution of the project stoves, enhanced focus is laid on verbally communicating the information about accessibility of project documents among CQC implementing partners, staff, and local population who are either project beneficiaries or potential project beneficiaries. In addition to verbal communications, a dedicated helpline number is provided to the end-users through which they can contact the IPs or CQC ground staff to access the project documents. Further, CQC also posts these reference documents on its website offering open access to all the stakeholders. An effort is also made to ensure that end-users understand the process of accessing these documents on website by providing them verbal communication as well as a flyer pictorially the steps to access this documentation. Efforts are made to publish links to these materials across CQC's social media footprint.

### 2.2.13 Information to Stakeholders on Assessment Process

CQC informs the beneficiaries and their families that they are participating in a project that distributes the TCLRS improved cookstove at an in-kind donation (labor and bricks

constructed from locally available resources) to improve their respiratory health, food security, family economy through reduced cost of firewood and time saving, and the environment. We also inform them of our need to track their successes and monitor key data, such as money spent on wood fuel and/or time spent collecting wood fuel, among other indicators. As CQC is committed to cultural integrity but must ensure the integrity of the project and programs, auditors, and stove champions, visit the families up to 2 times after implementation.

As the SD VISTA program progresses, the main forms of communication to stakeholders will be through stove champions, social media, and the CQC website. We will announce our participation through training, community sensitization programs, social media, public releases, and our website.

## 2.3 Project Management

### 2.3.1 Avoidance of Corruption

CQC and/or its affiliates and subsidiaries, as the primary project proponent, and those entities contracted as implementing partners, are committed to combating any form of corruption, bribery, embezzlement, fraud, favouritism, cronyism, nepotism, extortion, and collusion. CQC's employees sign a code of business ethics and conduct form that mandates performance of all duties with honesty, integrity, and impartiality, without improper preferential treatment of any person, and undergo mandatory anti-corruption and antibribery training as a condition of employment. CQC's implementation partners are required to review CQC's anti-corruption and anti-bribery policies and must take anticorruption and antibribery training before performing any project implementation services as a condition of their contract.

### 2.3.2 Statutory and Customary Rights

CQC operates from private homes, enhancing remote employment capabilities, and a central office location in Washington, D.C. U.S.A. Community sensitizations and training take place either on public land, i.e., a central town meeting point, or on private property with the explicit verbal invitation of the homeowner. The CQC implementing partners enter the kitchen space of the household to install the TLCRS only with the explicit permission of the household. Stove installations take place within rural areas of Malawi, and for the most part exclude the urban and peri-urban settings, although other projects will focus on these geographical areas in the future. CQC and its implementing partners take active consideration of individual and collective rights to ensure all rights are respected.

Land tenure in Malawi is divided into three categories: public, private, and customary lands. Public land is held by the government and used for purposes such as forest reserves, national parks, recreation areas, and conservation areas. Private land is exclusively owned or leased by entities. Customary land is any land falling under the jurisdiction of traditional authority, which can then grant that land to individuals, families, or communities for use under customary law.

Forests can fall into any of the three land tenure types. Mwase et al (2007) describe how both public and customary lands are, in practice, accessible and openly used for fuelwood extraction, despite protected status as forest reserves or control by chiefs as customary lands.

Malawi is divided into 28 districts which are overseen by District Commissioners and DEC. It is further divided into 250 Traditional Authorities, which are governed by the Chief and associated ADC. Each Traditional Authority contains multiple villages, which are overseen by Group Village Heads and VDCs.

Customary lands are central to the identity and livelihood of villages, and all smallholder production takes place on customary lands that have been allocated to households by Group Village Heads for subsistence cultivation. Governance of customary lands is overseen by Traditional Authorities, who grant the power to chiefs and Group Village Heads to distribute lands to smallholders. However, in practice, customary lands are typically treated as open access to all village members, with few restrictions or harvest limits.

Project activities take place on customary lands within villages that have been allotted to individual households by Group Village Heads. All project participants have tenure rights associated with the land the ICS is built.

### 2.3.3 Recognition of Property Rights

CQC's implementing partners only install a stove at the informed invitation of the household and CQC's ICS does not infringe or interact with property rights.

### 2.3.4 Free, Prior, and Informed Consent

The project activities will take place with the approval of Village Development Committees and Area Development Committees in a series of consultation meetings as documented. In addition, ICS is a completely voluntary activity and households in participating villages are free to choose whether they take part or not. Free, prior, and informed consent takes place before installation.

### 2.3.5 Restitution and/or Compensation for Affected Resources

CQC's installation of an ICS does not affect any party's access to resources or their lands; no negative effects have been identified.

### 2.3.6 Property Rights Removal/Relocation of Property Rights Holders

CQC's ICS installation does not impede, involuntarily remove, or relate the land or property rights of the beneficiaries or their families. ICS installation incentivizes the beneficiaries to end the use of three-stone fires and use project stoves for cooking activities. While this may change the cooking activity practices to some extent, post-implementation surveys of beneficiaries suggest that the ICS allows them to decrease cooking times while making identical food items as with three stone fires.. This is seen as clean technology adoption and not an infringement of important cultural activities.

The project activities do not involve the removal or relocation of property rights holders from lands or territories, nor do they force rights holders to relocate activities. The bamboo plantation and ICS activities are voluntary.

### 2.3.7 Identification of Illegal Activities

Theft and corruption are commonly identified as illegal activities in Malawi. As there is no transfer of funds at the beneficiary level, CQC expects to eliminate the cause of corruption. Theft of metal stove parts has occurred in the past and CQC has since implemented secure storage and direct hand-off of stove parts to reduce this occurrence.

### 2.3.8 Ongoing Conflicts or Disputes

There are no identified ongoing conflicts or disputes as the project scope does not involve rights to lands, territories, and resources. As the project implementation takes place within the private household, project activities would not interfere with the outcome of an unresolved dispute.

### 2.3.9 National and Local Laws and Regulations

CQC follows the Malawi Companies Act adhering to subsequent local and national laws. Project Implementors are registered with appropriate national authorities allowing them to conduct their operations, with CQC projects as an add-on. Relevant and applicable international and U.S. statutes and regulations are abided by.

### 2.3.10 Project Ownership

Beneficiaries agree to allow CQC to do the following:

- (1) Claim the GHG emission reduction and/or removals generated by the technology used by the CC ICS project.
- (2) Conduct follow-up and spot audits for increased adoption and monitoring purposes.

The stoves themselves are owned by the beneficiaries with in-kind contributions, including making and constructing the bricks for the construction of the TLCRS.

### 2.3.11 Grouped Projects

With CQC's group projects, secondary projects are identified through stakeholder assessment and development initiatives at the community level that we can meet. New project activities are assessed and evaluated to determine if they provide significant individual impacts (funding of education), household (cookstove), or community level (training on climate change, the importance of health and nutrition particularly of pregnant individuals and during the first 1000 days). Where projects are seen to provide significant impact, design is assessed for scalability and risk, with a focus on added values to in-country contracting, and transferability to other countries in sub-Saharan Africa. Following, new project activities are evaluated against current projects in their thematic buckets to determine if CQC and IPs have the bandwidth to take on additional projects. If acceptable, pilot projects on a small scale may begin to evaluate the implementation and identify necessary changes. CQC remains

committed to being flexible with the addition of new projects so long as current projects continue on their projected timelines and anticipated impact and benefit to the beneficiaries.

For the inclusion of new project activity instances i.e., ICS, the project proponent shall ensure that it meets the eligibility criteria below – per Appendix 1 – Grouped Projects (GP) of the SDVISTA Standard.

No.	Criterion	How the new project activity instances will comply
1.	Adopt and implement the project activities in the same manner as specified in the project description.	New project activity instances will be implemented in the same manner as described in the project description and will be implemented directly with beneficiaries of the TLCRS (TLC Rocket Stove), extending benefits and reinforcing project stove adoption
2.	Where appropriate, meet the applicability conditions of the SD VISTA asset methodology applied to a project.	The project activity as well as the new project instances do not apply for SD VISTA assets and hence this criterion is not applicable
3.	Are subject to the same scenarios at project start with respect to stakeholders' well-being as determined for initial project instance(s), where (per Section 2.1.5.2 above) the project must meet the criteria of Section 3.1 above	New project activity instances will have the same baseline scenario, which was available during the start of project, i.e., usage of three-stone open fire cookstoves in the households. Also, the instances will be designed to maximize intended impact and preserve well-being, with monitoring and ongoing stakeholder consultations to ensure impact,
4.	Are subject to the same scenarios at project start with respect to natural capital and ecosystem services as determined for initial project instance(s) where (per Section 2.1.5.2 above) projects must meet the criteria of Section 3.2 above.	New project instances will have the same scenario w.r.t natural capital and ecosystem services as determined in the baseline scenario. All the new instances will also have households relying on wood fuels for meeting their daily cooking energy demands.
5.	Are subject to the same processes for stakeholder engagement described in the project description	The new project activity instances will be detailed during continuous stakeholder consultations, refresher trainings for Implementing Partners and feedback consider in secondary

		project activity design to maximize intended impact and preserve well-being.
6.	Are subject to the same processes for respect for rights to lands, territories and resources – including free, prior and informed consent – described in Section 2.4 above.	The outlined Project Management (Section 2.3) will apply for each additional project activity
7.	Secondary projects will have similar monitoring elements to those set out in the project description	Additional projects will have equivalent monitoring plans and procedures as described in Section 3.3

## 3 BENEFITS FOR PEOPLE AND PROSPERITY

### 3.1 Condition of Stakeholders at Project Start

**Current and Potential beneficiaries-** As smallholder subsistence agriculture farmers, the stakeholders in Malawi are especially susceptible and vulnerable to the impacts of the climate crisis. As a landlocked country with over 20 million people, high population density, and a growing demographic, deforestation and degradation and widespread soil erosion are growing concerns to the agriculture-based economy that has experienced decades of increasing climate shocks<sup>15</sup>.

Traditionally households use TSF, contributing to 15% of global energy use, large amounts of black carbon, and carbon-based greenhouse gases<sup>16</sup>. Biomass for the cookfires is mainly locally procured firewood. This firewood is typically large diameter logs that the women and children, primarily girls, are responsible for collecting. As the population has increased and rapid deforestation results, where the industry is also a contributor, women, and children have had to travel farther distances to gather firewood for their three-stone cookfires. Cooking on three-stone cookfires occurs in a closed walled building, made from locally available resources. With these low-efficient cookfires, women and children are exposed to HAP for extended durations, resulting in high levels of Chronic Obstructive Pulmonary Disease (COPD), asthma, and other negative respiratory effects<sup>17</sup>. Due to the long cooking time on the inefficient TSF, much of nutrients in the food is lost resulting in consumption of lower nutrient rich food.

**Implementing Partners-** The condition of implementing partners at the start of the project varies between partners and their organizational network and structure. Traditionally, partners are considered based on their current or prior scope of work, existing networks, history of development projects of similar scope or significance, history of work within communities of project implementation and general standing. The TLCRS project is often coupled with existing projects under the IPs work portfolio, for example, increased water access or reforestation.

**CQC employees in the host country-** Malawi's population has quadrupled to reach 17.6 million in 2018 post its independence in 1964. The population predominantly reside in rural areas and rely on agricultural activities for sustaining their livelihoods. It has been reported that 88% of the employed working age (15 to 64 years) population in Malawi works in agriculture sector only. Although the services sector has grown significantly over the past 20 years, with a small manufacturing sector and limited non-agricultural natural resources to exploit, agricultural production remains at the centre of most economic production. Apart from being agrarian, Malawi has the youngest age structure with 44% of its population under the

---

<sup>15</sup> USAID, 2016

<sup>16</sup> Jeuland and Pattanayak, 2012

<sup>17</sup> Rosenthal et al., 2018

age of 15, and 34% being between 15 and 35 years of age<sup>18</sup>. This indicates that there is a high probability of Malawian youth to remain unemployed or be associated with low income generating activities. However, through this project activity including distribution of ICS as well as development of Ener-G Africa, CQC is generating employment opportunities for the local people of Malawi, thus, improving the overall social status of the community.

### 3.2 Expected Impacts on Stakeholders

<b>Impact #1</b>	Promote sustainable and resilient agricultural practices
<b>Type of Impact</b>	Positive, Predicted, Direct
<b>Affected Stakeholder Group(s)</b>	Beneficiaries, beneficiaries' families
<b>Resulting Change in Well-being</b>	By distributing drip irrigation kits, the end users will not only be able to manage irrigation more efficiently but will also be able to grow vegetables/crops even in dry season. This will improve their food security.

<b>Impact #2</b>	Promotion of sustainable and resilient agricultural practices
<b>Type of Impact</b>	Positive, predicted, indirect
<b>Affected Stakeholder Group(s)</b>	Land and Soil quality of backyard gardens of households
<b>Resulting Change in Well-being</b>	The distribution of bamboo seedlings will ensure improvement in land and soli quality of the backyard gardens in the beneficiary households

<b>Impact #3</b>	Improved Health Status
<b>Type of Impact</b>	Positive, Predicted, Direct
<b>Affected Stakeholder Group(s)</b>	Beneficiaries, Beneficiaries' families, specifically children and infants under 5 years old

<sup>18</sup> IFPRI, 2019; [https://massp.ifpri.info/files/2019/01/MaSSP\\_WP27\\_EmploymentLandscape- final.pdf](https://massp.ifpri.info/files/2019/01/MaSSP_WP27_EmploymentLandscape- final.pdf)

<b>Resulting Change in Well-being</b>	Lowered risk of developing COPD or worsening COPD, less instance of acute lower respiratory illness, anticipated reduction of burns due to contained flames in the combustion chamber, improved overall respiratory health.
<b>Impact #4</b>	Trainings imparted on climate change, project implementation and monitoring procedures
<b>Type of Impact</b>	Positive, Predicted, Indirect
<b>Affected Stakeholder Group(s)</b>	Implementing Partner Staff, CQC Country Staff
<b>Resulting Change in Well-being</b>	Training and skill development related to community engagement, survey implementation, technical trainings like conducting Water Boiling Tests (WBT) will be provided to many stakeholder groups which is envisaged to empower their lives by not only improving their employment chances but also through increased awareness levels regarding issues related to climate change, social equity.
<b>Impact #5</b>	Reduction of time spent on unpaid domestic work
<b>Type of Impact</b>	Positive, Predicted, Direct
<b>Affected Stakeholder Group(s)</b>	Beneficiaries (most notably, female, elderly, and children, primarily girls)
<b>Resulting Change in Well-being</b>	Females who spend a copious amount of time on unpaid domestic labor, multiplied by the double/triple burden effect, have a predicted time saving which can be redirected to income-generating activities or relaxation time, contributing to enhanced conditions for gender equity.
<b>Impact #6</b>	Using TLCRS enabling access to clean technology
<b>Type of Impact</b>	Positive, Predicted, Direct
<b>Affected Stakeholder Group(s)</b>	Project Beneficiaries and their families

<b>Resulting Change in Well-being</b>	Decreased reliance on wood fuel leads to resource conservation and promotes clean technology use.
---------------------------------------	---

<b>Impact #7</b>	Improved Economic Outcomes
<b>Type of Impact</b>	Positive, Predicted, Indirect
<b>Affected Stakeholder Group(s)</b>	Beneficiaries, Beneficiaries' Families, primarily female children
<b>Resulting Change in Well-being</b>	Families predict money and times savings with fuel efficiency reducing costs of firewood purchases and/or time savings on the collection of wood.

<b>Impact #8</b>	Industrialization and resilient infrastructure around the project area
<b>Type of Impact</b>	Positive, predicted, direct
<b>Affected Stakeholder Group(s)</b>	Local people around project area
<b>Resulting Change in Well-being</b>	The establishment of Ener-G-Africa will lead to development of resilient infrastructure and industrialization of the project area. Establishment of the manufacturing unit will not only generate employment opportunities for local people in and around project area but also improve the socio-economic profile of local people in the region.

### 3.3 Stakeholder Monitoring Plan

This section explains the monitoring approach that will be undertaken by the PP to monitor the impacts of the designed project activities observed on the key stakeholders associated with the project activity. The impact mapping for every stakeholder has been conducted with respect to the potential SDG claimable for that stakeholder category.

The following tables describes the mapping of project activity with impacts on stakeholder classes and the monitoring parameter that will be used to assess the intended and unintended impacts of the project activities:

<b>Impact #9</b>	Reduced income of fuelwood vendors
<b>Type of Impact</b>	Negative, unpredicted, Indirect
<b>Affected Stakeholder Group(s)</b>	Local fuel wood vendors
<b>Resulting Change in Well-being</b>	There is a possibility that reduction in the demand of wood-fuel associated with usage of energy efficient ICS might affect the vendors selling fuel wood in Malawi. However, considering the significant demand-supply gap and the over reliance of Malawi population on fuelwood for cooking needs, decrease in the fuel-wood demand in project location is not likely to have a significant negative impact on wood vendors.



S.No.	Stakeholder Group Impacted	Impact	SDG Indicator	Monitoring parameters	Monitoring Approach	Sampling	Monitoring frequency						
1	End User Household	Increased household ability to grow to grow crops/vegetables in dry season	2.4	Monitor the number of households receiving drip irrigation kits under project activity	$N_{DIK,y} = N_{DIK,y} (1 - DF)^{y-1}$ Where: <table border="1"> <tr> <td><math>N_{DIK,y}</math></td> <td>Number of Drip Irrigation kits (DIK) operational in the project area, in turn representing promotion of sustainable agricultural practices in project scenario</td> </tr> <tr> <td>y</td> <td>Year of consideration</td> </tr> <tr> <td>DF</td> <td>Failure rate of drip irrigation kits. A default factor of 4% is considered for estimating the number of operational DIK estimated using field survey conducted at the start of project activity.</td> </tr> </table> Source: Drip Irrigation kits distribution records	$N_{DIK,y}$	Number of Drip Irrigation kits (DIK) operational in the project area, in turn representing promotion of sustainable agricultural practices in project scenario	y	Year of consideration	DF	Failure rate of drip irrigation kits. A default factor of 4% is considered for estimating the number of operational DIK estimated using field survey conducted at the start of project activity.	100 per cent of data	Once at the start of project
$N_{DIK,y}$	Number of Drip Irrigation kits (DIK) operational in the project area, in turn representing promotion of sustainable agricultural practices in project scenario												
y	Year of consideration												
DF	Failure rate of drip irrigation kits. A default factor of 4% is considered for estimating the number of operational DIK estimated using field survey conducted at the start of project activity.												
2	End User Household	Sustainable supply of fuel wood for future	2.4	Monitor the total number of bamboo seedlings distributed	$N_{live\ plant} = N_{seedlings,year\ 1} \times 0.75$ Where: <table border="1"> <tr> <td><math>N_{live\ plant}</math></td> <td>Total number of live bamboo plants<sup>19</sup></td> </tr> <tr> <td><math>N_{seedlings,year\ 1}</math></td> <td>Total number of bamboo seedlings distributed at the start of project activity. A default mortality rate of 25% as available in published literature<sup>20</sup> has been used to estimate the minimum number of plants that survive.</td> </tr> </table> Source: seedling purchase invoices.	$N_{live\ plant}$	Total number of live bamboo plants <sup>19</sup>	$N_{seedlings,year\ 1}$	Total number of bamboo seedlings distributed at the start of project activity. A default mortality rate of 25% as available in published literature <sup>20</sup> has been used to estimate the minimum number of plants that survive.	100 per cent of data	At the time of each verification		
$N_{live\ plant}$	Total number of live bamboo plants <sup>19</sup>												
$N_{seedlings,year\ 1}$	Total number of bamboo seedlings distributed at the start of project activity. A default mortality rate of 25% as available in published literature <sup>20</sup> has been used to estimate the minimum number of plants that survive.												

<sup>19</sup> The total number of bamboo seedlings that will survive post first year. The value is fixed for entire crediting period given the fact that the project will continue with the distribution activity at intervals throughout the project life to maintain a sustained supply of fuel wood for project stoves as well as ensure source of livelihood for the local women who could sell products made from bamboo.

<sup>20</sup> <https://www.undp.org/malawi/stories/>

3	End User Household (Primary cook)	Reduced exposure to PM <sub>2.5</sub> emissions and household air pollution	3.9	Reduced PM <sub>2.5</sub> emissions	$Net\ Benefit = PM_{2.5\ baseline} - PM_{2.5\ project}$ where <table border="1" data-bbox="990 280 1554 480"> <tbody> <tr> <td><math>PM_{2.5\ baseline}</math></td> <td>PM<sub>2.5</sub> emissions in baseline stoves (TSF) default of 52.699 mg/min (or 3.9 g/Kg fuel) <a href="http://CleanCookingCatalog.org">Clean Cooking Catalog (cleancookstoves.org)</a></td> </tr> <tr> <td><math>PM_{2.5\ project}</math></td> <td>PM<sub>2.5</sub> emissions in project stoves.</td> </tr> </tbody> </table> Source: Lab test report of Project stoves providing emission level of PM <sub>2.5</sub> <sup>21</sup> .	$PM_{2.5\ baseline}$	PM <sub>2.5</sub> emissions in baseline stoves (TSF) default of 52.699 mg/min (or 3.9 g/Kg fuel) <a href="http://CleanCookingCatalog.org">Clean Cooking Catalog (cleancookstoves.org)</a>	$PM_{2.5\ project}$	PM <sub>2.5</sub> emissions in project stoves.	Simple Random <sup>22</sup> sampling with 90 per cent confidence interval and a 10 per cent margin of error	At the start of the project
$PM_{2.5\ baseline}$	PM <sub>2.5</sub> emissions in baseline stoves (TSF) default of 52.699 mg/min (or 3.9 g/Kg fuel) <a href="http://CleanCookingCatalog.org">Clean Cooking Catalog (cleancookstoves.org)</a>										
$PM_{2.5\ project}$	PM <sub>2.5</sub> emissions in project stoves.										
4	CQC staff	Skill set development and awareness generation	4.4	Number of individuals trained	$Net\ Benefit = Training_{project} - Training_{baseline}$ Where- <table border="1" data-bbox="990 595 1554 820"> <tbody> <tr> <td><math>Training_{project}</math></td> <td>Trainings provided in project scenario</td> </tr> <tr> <td><math>Training_{baseline}</math></td> <td>Trainings provided in baseline. A value of 0 shall be considered as in absence of project activity, these trainings would not have been undertaken by PP or PI.</td> </tr> </tbody> </table> Source: Training Records Feedback forms	$Training_{project}$	Trainings provided in project scenario	$Training_{baseline}$	Trainings provided in baseline. A value of 0 shall be considered as in absence of project activity, these trainings would not have been undertaken by PP or PI.	100 percent of data	To be monitored for the duration of monitoring period at the time of each verification
$Training_{project}$	Trainings provided in project scenario										
$Training_{baseline}$	Trainings provided in baseline. A value of 0 shall be considered as in absence of project activity, these trainings would not have been undertaken by PP or PI.										
5	Women and young girls	Reduced drudgery	5.4	Proportion of users reporting time saving due to reduction in fuel collection amount and faster cooking on project stoves	$Net\ Benefit = T_{baseline} - T_{project}$ Where- <table border="1" data-bbox="990 963 1554 1184"> <tbody> <tr> <td><math>T_{baseline}</math></td> <td>Average time spent in fuel collection and cooking in baseline scenario. Determined once prior to or concurrent with first verification. A fuelwood collection time of 2 hours/day/household determined from survey has been used as a baseline value.</td> </tr> </tbody> </table>	$T_{baseline}$	Average time spent in fuel collection and cooking in baseline scenario. Determined once prior to or concurrent with first verification. A fuelwood collection time of 2 hours/day/household determined from survey has been used as a baseline value.	Simple Random sampling with 90 per cent confidence interval and a 10 per cent margin of error achieved for monitored parameter	Annually/ Biennially		
$T_{baseline}$	Average time spent in fuel collection and cooking in baseline scenario. Determined once prior to or concurrent with first verification. A fuelwood collection time of 2 hours/day/household determined from survey has been used as a baseline value.										

<sup>21</sup> Details on PM<sub>2.5</sub> estimation for subsequent years has been provided in Appendix F of the document

<sup>22</sup> Data on number of stoves which are operational in a monitoring period to be imported from corresponding VCS project activity.

					$T_{project}$ Average time spent in fuelwood collection and cooking in project scenario Source: monitoring surveys conducted to determine average time saved in project scenario.		
6	End User Households	Affordable and clean energy	7.1	Monitor proportion of ICS distributed and operating under project as an indicator of clean technology	$Net\ Benefit = ICS_{project} \times N_y$ where $ICS_{project}$ Number of ICS installed representing access to clean technology in project scenario $N_y$ Proportion of operational stoves Source: ICS distribution records and ex-post monitoring surveys conducted to determine proportion of operational stoves	$ICS_{project}$ -100% of data $N_y$ - Simple Random sampling with 90 per cent confidence interval and a 10 per cent margin of error achieved for monitored parameter.	Annually/ Biennially
7	Implementation Partners and Survey Agencies	Employment generation	8.3	i. Number of local people employed for ICS distribution activities ii. Number of local people employed for conducting impact survey.	$Net\ Benefit = ES_{project} - ES_{baseline}$ where $ES_{project}$ Gainfully employed staff in project scenario. $ES_{baseline}$ Gainfully employed staff in baseline. A value of 0 shall be considered as in absence of project activity no employment opportunities would have been created. Source: employment records	100% of data	To be monitored for the duration of monitoring period at the time of each verification
8	Local community residing within the project boundary	Sustainable industrialization	9.2	Annual revenue of Ener-G-Africa that comes from CQC's stove part orders	$Net\ Benefit = N \times Cost_{metal\ parts}$ where $N$ Number of stoves for which the stove parts are procured from Ener-G Africa $Cost_{metal\ parts}$ Cost of metal parts of one stove Source: Sample Stove procurement invoices between CQC & Ener-G Africa	Stove Distribution records and sample invoices (to demonstrate rate of metal parts for stove)	To be monitored for the duration of monitoring period at the time of each verification

## Sampling Plan

The end-user impact survey indicated in the table above refers to the primary survey that will be conducted to assess the impacts associated with the implementation of project activities. The following section describes the sampling approach that will be adopted to conduct these surveys.

**Target Population:** The quantification of benefits achieved through the project will be conducted by consulting the **end-user beneficiaries, i.e., the households** that have received the ICS.

**Sampling Method:** Simple random technique will be adopted to conduct sampling survey among ICS batches. This approach will be adopted owing to the following aspects:

- Homogenous nature of the project activity, i.e., *common technology* (ICS) with similar operating characteristics being distributed across different states/province of the country.
- Existing of homogeneous sub-population

To ensure a random selection of ICS, random number generators shall be applied. Each ICS in the target population is uniquely identifiable by its unique ID number. Each ICS can thus be allocated a Sample Selection Number in each monitoring period, starting at 1 and increasing up to the total number of ICS in the database for that pre-defined sampling frame. Applying the random number generators, the ICS can then be randomly chosen from the defined population up to the required sample size as calculated by the project proponent.

Sampling Unit: Households that have received project stoves

Sampling Parameters: The following two parameters are used to estimate the sample size:

$N_{y,i,j}$ :	Visual inspection of the premises to see if ICS is operational and in use. Interview with end user if required to verify that ICS is still in use (Yes/No)
$B_{y=1,new,i}$ survey	Interview with end user for determining average quantity of firewood used in the project stove per day. Measurement campaigns for estimation of consumption of wood in project households. (Wood fuel quantity)

Sample Size: For the estimation of the proportion or mean value of the parameters investigated, the minimum sample size for each sample frame must achieve the 90/10 confidence/precision. The procedure to determine the sample of households will ensure that they adequately represent the broader project population, minimizing sampling error. Using a 90 per cent confidence level, and a 10 per cent margin of error, random samples will be selected from each Primary Sampling Unit. To calculate the required sample size estimates, proportions and the mean values are required. Furthermore, the standard deviation needs to be assumed in case of sampling for a mean value. As per Guidelines for Sampling and surveys for CDM project activities and programmes of activities, there are different ways available to obtain the estimates of the parameter of interest:

- a) Refer to the result of previous studies and use these results.
- b) In a situation where information from previous studies is not available, a preliminary sample as a pilot could be conducted and use that sample is used to provide the estimates.
- c) Use best guesses based on the researcher's own experiences.

For the registration purpose of project, option (c) as stated above shall be applied. For the following monitoring periods, the estimates can be adjusted taken the results of the previous monitoring period(s) into account or the result from recent pilot study which is conducted after the previous monitoring periods.

The following assumptions are made to exemplify the sample size calculation for the parameters.

1. An overview of the estimated sample sizes for a hypothetical population of 100,000 ICS units applying a level of 90/10 is provided below. It is likely that all the sample frames for each parameter will include fewer than 100,000 ICS in the first monitoring period, so this is a conservative approach. Hence, population size,  $N$ , is taken as 100,000 households/ICS (Assuming one ICS for one household).
2. It is expected at least 80% of ICS still in operation, hence the expected proportion  $p$  is taken as 0.8.

Sample size calculation:

Parameter  $N_{y,i,j}$ :

The calculation of the required sample size for each parameter in the first monitoring period is illustrated below. In all cases a conservative approach is taken, however if for any parameter the required confidence/precision is not met then the Coordinating and Managing Entity (CME) will randomly select an additional sample and collect further data from this sample to ensure the pooled data meet or exceed the required thresholds.

Based on the above assumptions, the resulting sampling size is calculated as:

$$n \geq \frac{1.645^2 \times 100,000 \times 0.8(1 - 0.8)}{(100,000 - 1) \times 0.1^2 \times 0.8^2 + 1.645^2 \times 0.8(1 - 0.8)} = 67.61$$

Therefore, in this case a sample size of 68 is to be sampled from each primary sampling unit.

Parameter  $B_{y=1, \text{new}, i, \text{survey}}$ :

For the purposes of determining sample size in the first monitoring period, the performance of ICS is characterized by the range of likely mean wood consumption and the likely values of SD relative to the mean, according to the type of ICS. The ICS models that are manufactured in modern factories tend to be very highly efficient (30-50% thermal efficiency) and have been designed to meet stringent efficiency specifications, so the standard deviation is expected to be relatively low.

To estimate the sample size for parameter  $B_{y=1, \text{new}, i, \text{survey}}$  the following equation is used:

$$n \geq \frac{1.645^2 NV}{(N - 1) \times 0.1^2 + 1.645^2 V}$$

Where:

$$V = \left( \frac{SD}{mean} \right)^2$$

$n$  = Sample size

$N$  = Population size (Total number of households/ICS)

$mean$  = Expected mean of ICS thermal efficiency

$SD$  = Expected standard deviation

1.645 = Represents the 90% confidence required

0.1 = Represents the 10% relative precision

Based on the above assumptions, the sample size calculation would be

$$n \geq \frac{1.645^2 \times 100,000 \times \left( \frac{0.076}{0.38} \right)^2}{(100,000 - 1) \times 0.1^2 + 1.645^2 \times \left( \frac{0.076}{0.38} \right)^2} = 10.82$$

The resulting sample size based on the above equation is smaller than 30, since  $B_{y=1, new, i, survey}$  is a numeric mean value (i.e. not a proportion or percentage) the Student's t-distribution shall be used as per paragraph 14 of "Standard for Sampling and Surveys for CDM Project Activities and Programme of Activities, version 09.0.

The sample size for parameter  $B_{y=1, new, i, survey}$  under t-distribution is referred to the equation below:

$$n = \left( \frac{t_{n-1} \times SD}{0.1 \times mean} \right)^2$$

Where  $t_{n-1}$  is the value of the t-distribution for 90% confidence when the sample size is  $n$ . Since the sample size is not known yet, the first step is to use the value for 90<sup>23</sup>% confidence when the sample is large, i.e., 1.645 and then redefine the calculation.

$$n = \left( \frac{1.645 \times 0.076}{0.1 \times 0.38} \right)^2 = 10.82$$

Thus,  $n$  is rounded up to 11.

The calculation now needs to repeat using t-value for 90% confidence and  $n = 11$

$$n = \left( \frac{2.228 \times 0.076}{0.1 \times 0.38} \right)^2 = 19.86$$

And  $n$  is rounded to 20.

---

<sup>23</sup> For CPAs not qualifying the conditions under paragraph 12 of Tool 19, the requirements of the applied methodology shall apply.

The calculation now needs to repeat using  $t_{n-1}$  value for  $n = 20$ . The process should be iterated until there is no change to the value of  $n$ .

$t_{19-1}$	2.093
$n=$	17.52
Round up	18

$t_{18-1}$	2.110
$n=$	17.81
Round up	18

The repeated calculation shows that  $n = 18$ . Thus, the sample size to be sampled from each sampling unit is 18.

Since parameters  $\mathbf{N}_{y,j,j}$ , and  $\mathbf{B}_{y=1,new,i, survey}$  share the same sampling units, CME may choose to have one common survey for these two parameters with largest number of sample size between these two parameters being chosen. Sampling more than one parameter within the same sample (household) helps reduce travel needs for monitoring and the associated costs. At the same time this approach ensures the random selection of samples for every parameter.

Oversampling is strongly encouraged, not only to compensate for any attrition, outliers or non-response associated with the sample, but also to prevent a situation at the analysis stage where the required reliability is not achieved, and additional sampling efforts would be required. The sample size shown above will be adjusted upwards to account for non-responses, CME shall determine the appropriate non-responses rate based on previous experience.

**Data type and data collection tool:** Qualitative data regarding the benefits and co-benefits aligned with project implementation will be collected from end-users to obtain unbiased and reliable information of the SDGs claimed under the SD VISta programme. This will be captured through a structured questionnaire which will be prepared based on effective brainstorming, review of literature and baseline scenario assessment of the project locations. Questionnaire comprising of both open and closed ended questions will be adopted to gather feedback from the end-users and relevant stakeholders within the countries.

**Quality Assurance/ Quality Control:**

PP will apply measures to ensure the required confidence/precision for each sampled parameter is met, allowing for non-response and the possible removal of outliers from the sample, as part of a Quality Control/Quality Assurance system. The choice of measure applied to each parameter will depend on the cost of each data collection approach and logistics required. The PP will determine the most effective measure for each parameter from the following list (illustrated using a required sample size of 20 and an effect of non-response of 2 to 4 ICS):

- Oversampling: Randomly draw a sample of minimum 24 ICS and collect data from each

- Buffer Group: Randomly draw a sample of at minimum 24 ICS and collect data from only 22 ICS. If this would not result in the required sample size data would be collected from the additional 2 ICS that were selected in the sample.
- Draw an additional sample: Randomly draw a sample of 22 ICS and collect data from these. If the required sample size is not achieved, an additional sample of 2 elements will be drawn and included in the sample.
- Use lower confidence bound (of  $N_{y,i,j}$ ,  $B_{y=1,new,i, survey}$ ) or, with a conservative approach according to the parameter definitions,

The CME may choose to stop monitoring a particular parameter once the required level of confidence/precision has been reached, if the calculated minimum number of samples has been achieved. As an example, the following steps could logically be followed for the case of applying a 30% buffer:

1. Visit first 10% of premises required for the 30% buffer. If the number of responses is sufficient to achieve the required reliability level, then stop sampling.
2. If step 1 is not sufficient to achieve the required reliability level, then visit the next 10% of premises (increases the additional sampling to 20% of the 30% buffer). If this additional sampling is sufficient, then stop sampling.
3. If step 2 is not sufficient to achieve the required reliability level, then complete the final 10% of the additional sampling buffer (bringing the total to 30%).

The sampling plan has the following procedures in place to ensure good quality data. The CME will ensure that field personnel have reviewed, understand, and have signed the monitoring plan, including provisions for maximizing response rates, documenting out-of-population cases, refusals, and other sources of non-response. A quality control and assurance strategy will be documented. Quality control and assurance strategies include addressing non-sampling errors, such as non-response or bias from interviewer. The monitoring plan will explain how to properly survey households to prevent bias from interviewer. In the case a household refuses to participate, another household will be chosen at random. To reduce interviewer bias, good questionnaire design and well-tested questionnaires will be used.

The calculation of the sample size will be carried out using estimates for parameter proportions, mean values and standard deviations, as the actual characteristics of the population/sampling frame are unknown. To ensure the quality of the sampling results, the CME can draw on the provisions for reliability calculations as provided by the Guidelines for Sampling and Surveys in CDM Project Activities and Programme of Activities (version 04). If the sampling results do not fulfil the required level of confidence and precision, the CME can undertake additional samples. If the reliability is still not sufficient after additional samples or other measures, the sampling may be repeated with an increased sample size. Alternatively, the CME may choose to apply the lower bound or higher bound according to the more conservative approach.

### **Data archiving**

Hard copies of the surveys will be kept, and the registration database will have back up. Original stove purchase contracts or other means of acceptance by the users will be stored in the main office for the coordinating entity. A back-up of the registration database will also

be stored on an electronic medium by the PP. All data monitored and required for verification and issuance will be kept for two years after the end of the crediting period or the last issuance of VCUs for the project activity, whichever is later.

### **Analysis**

The PP will manage a project database that includes the following data that can be directly attributable to the project activity, thereby allowing unambiguous determination of the emission reductions attributable the project:

- A list of households participating in project activity, including name, community/location, distribution date and unique serial number
- Where replacements are made, assurance that the efficiency of the new ICS is like the specified

Data obtained from the samples will be used to estimate proportions and mean values for the parameters described above. The values will then be factored into the emissions reduction calculations and result in the request for issuance of VCUs. The stoves that are not in use will be excluded from emissions reductions calculations and will not be counted towards the total number of ICS in operation during the monitoring period.

### **Implementation**

Sampling for the purpose of emission reduction calculation and elaboration of the monitoring report will occur at the end of each monitoring period. This sampling will be conducted by trained personal either part of the CPA Implementer or CME team, or an experienced third-party entity. The maximum length of one monitoring period will be two years (duration, not calendar years). The CPA Implementer will be responsible for managing household data collection and entry into the project database. Field personnel will receive training on how to properly deal with surveying techniques and reduce errors and sign a document certifying that there is no conflict of interest of those involved in data collection and analysis. If there is conflict of interest, the personnel will not be allowed to participate in data collection and analysis. The project database will record the start and end dates of each monitoring period and record the emission reductions attributable to each monitoring period. Appropriate record keeping procedures will be implemented to ensure that each monitoring period data set can be transparently attributed to its corresponding CPA, preventing any occurrences of double counting. An internal review of the project database will be able to determine the status of project the duration of previous monitoring periods, the households delivering monitoring data, and current verification activities.

### ***Assessment for Leakage***

According to methodology VMR 0006, version 1.1, section 8.3; Leakage shall be considered as default 0.95 in accordance with Section 5.4 of AMS-II.G. therefore default value of leakage as 0.95 will be applied.

### ***Monitoring Reporting***

The PP will assess all monitoring data and produce one or two monitoring reports for the project for the VVB to verify corresponding to the preceding monitoring period the project.

This report will present the data relating to the emission reductions generated by the project at the time of the monitoring period.

### 3.4 Net Positive Stakeholder Well-being Impacts

All the impacts identified in section 3.2 except for six, which is “Fewer wood vendors” generate a positive impact on the stakeholders. However, considering that ~91% of the rural population of Malawi rely on wood-fuel and there exists a significant demand-supply gap for fuel wood in the country, any reduction in demand for wood fuel within project boundary will shift the stakeholders selling wood to outside project boundary, without causing significant reduction in their business as there would still exist a considerable demand for the product. Even though impact on fuel sellers is an unintended negative impact because of the project activity, but based on the existing scenario in Malawi, it does not make considerable impact and outweighed by the positive impacts of the following combined, long-term sustainable development benefits observed for the project’s stakeholders:

1. Beneficiaries will have a greater capacity to save money used for buying wood fuel due to the reduced demand of fuel wood for cooking purposes
2. Beneficiaries will have a greater opportunity to grow crops and vegetables in dry season due to the availability of drip irrigation kits providing access to continuous source of water
3. Beneficiaries will have continued access to wood fuel due to the distribution of bamboo seedlings
4. Women and young girls will have to spend less time on hard menial, unpaid and dull work of collecting wood fuel and household chores like cooking
5. Women and young girls can use the time saved from cooking and fuel wood collection in more productive activities which can generate income as well
6. Women and children will be exposed to lower levels of HAP, as ICS would reduce the amount of PM<sub>2.5</sub> emissions being released from cookstoves
7. Improved health status is expected to be achieved for all the household members due to reduced levels of HAP
8. Fewer children will be on a risk of experiencing burn injuries associated with open cooking fires
9. Local individuals will be trained and have better vocational skills enhancing their long-term employability and influencing their overall social and economic well-being
10. Local individuals around the project boundary will have access to increased employment opportunities by the development of Ener-G Africa, the stove manufacturing industry in Malawi. The constitution of this industry will not only contribute to developing resilient infrastructure and industrial development but also improve the overall socio-economic status of local communities in and around the project location

## 4 BENEFITS FOR THE PLANET

### 4.1 Condition of Natural Capital and Ecosystem Services at Project Start

The condition of natural capital and ecosystem services in Malawi on or around the start of the project has been described as a tipping point for deforestation. With 89% of Malawian's dependent on wood biomass to meet their energy needs, at the current rate of deforestation, it is estimated that Malawi would be stripped of all of its trees as early as 2079, with some projects earlier than this date due to the rapid growth in population size (203 people/km in 2020 vs. 118 in 2000) and a large portion of the population in younger aged individuals (median age is 18.1 years old) and a growing life expectancy of 60+ years from 2020 up from 40+ years in the early 2000s. As of 2000, 12% of Malawi had natural forest cover – 1.45Mha natural forest, 94.7Kha as plantations, and 10.3Mha non-forest. However, there is no intact forest in Malawi, defined as “unbroken expanses of natural ecosystems within the zone of forest extent that show no signs of significant human activity and are large enough that all native biodiversity, including viable populations of wide-ranging specifics, could be maintained.”<sup>24</sup>

Although the cutting of trees for commercial use is illegal in Malawi it has been fuelled in recent years by the urban migration (18%+ and growing rapidly) and the urban demand for charcoal in tandem with the international demand for hardwoods. This rapid deforestation has led to increasing catastrophic impacts on biodiversity, ecosystem, weather patterns, climatic shocks, and wildlife. In 2016, the government of Malawi deployed armed forces to protect forest reserves that were being heavily targeted by illegal logging efforts. Between 2019 and 2020, there was a rapid increase in the loss of 102ha of primary forest.<sup>25</sup>

Since 2000, Malawi has lost 193kha of tree cover, equivalent to a 13% decrease and 52.3Mt of CO<sub>2</sub> released into the atmosphere. Since 2002, Malawi has lost 420ha of humid primary forest, making up .22% of total tree cover loss, with a total area of humid primary forest decrease of 8.0% at the same time. Between 2010-2020, a total of 9.39MT of aboveground biomass was released into the atmosphere because of tree cover loss, equivalent to 854kt per year. At the same time, a total of 17.2MT of CO<sub>2</sub> was released into the atmosphere because of tree cover loss, equivalent to 1.56 Mt per year.

---

<sup>24</sup> Global Forest Watch. “Emissions from biomass loss in Malawi”. [www.globalforestwatch.org](http://www.globalforestwatch.org).

<sup>25</sup> Global Forest Watch. “Emissions from biomass loss in Malawi”. [www.globalforestwatch.org](http://www.globalforestwatch.org).

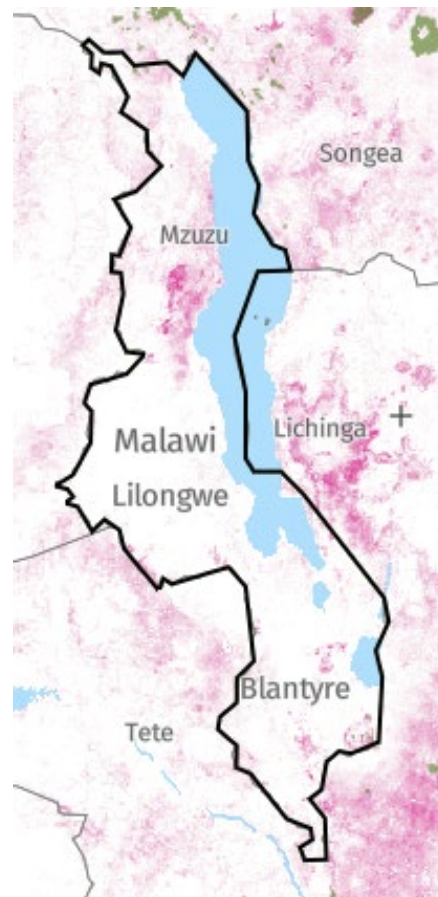

Image 4: Map of Malawi from Global Forest Watch Green sections identify tree cover

Image 5: Map of Malawi from Global Forest Watch the pink color depicts tree cover loss

## 4.2 Expected Impacts on Natural Capital and Ecosystem Services

<b>Impact #1</b>	Avoided emission of GHGs made possible through the use of TLCRS
<b>Type of Impact</b>	Positive, predicted, indirect
<b>Affected Natural Capital and/or Ecosystem Service(s)</b>	Air quality in the households as well as surroundings
<b>Resulting Change in Condition</b>	The project stoves require less fuel wood for producing same amount of thermal energy therefore resulting in lesser carbon dioxide emission in the atmosphere. As carbon dioxide is a greenhouse gas, its reduced emission translates to positive impact against climate change.

<b>Impact #2</b>	Reduced demand for large diameter non-renewable firewood from live trees due to only needing finger-sized woody biomass, i.e., twigs and crop residues, for cooking on the TLCRS
<b>Type of Impact</b>	Positive, actual, direct
<b>Affected Natural Capital and/or Ecosystem Service(s)</b>	Live plant biomass, Biodiversity and species Richness, Soil and Water Conservation
<b>Resulting Change in Condition</b>	By slowing the consumption of woody biomass for cooking purposes and by eliminating the need for large diameter woody biomass due to the technology in the TLCRS, the resulting drop in demand slows deforestation, thus increasing the above ground biomass in the adjoining forests near the project area. Reduction in unsustainable harvesting of plant biomass would in turn reduce soil erosion and result in improvement in biodiversity and species richness of the implementation area.

### 4.3 Natural Capital and Ecosystem Services Monitoring Plan

In addition to monitoring the ICS implemented each year, CQC will monitor the following to evaluate the net ecological impact of the project:

- Survey the amount of woody biomass used to fuelwood to meet the thermal energy needs for meal preparation on the TLCRS and calculate the reduction in woody biomass used in comparison to a TSF cookstove.
- Natural capital use will also be monitored through fuel use studies contracted by CQC to academic partners. Through these studies, CQC will ascertain the natural capital savings, specific to impacts 1 and 2 in the above charts.

The following data and parameters will be monitored under the project to assess the impacts on the natural capital and ecosystem. The sampling approach adopted for collecting the corresponding data has been presented in section 3.3 of the PD.

S.No.	Natural Capital Impacted	Impact	SDG Indicator	Monitoring parameters	Monitoring Approach	Sampling	Monitoring frequency
1	Atmosphere	Reduced levels of emissions and household air pollution	13.0	Reduced GHG emissions	$ER_{y,i,j} = B_{y,sav,i,j} \times N_{o,i,j} \times n_{y,i,j} \times \mu_y \times f_{NRB,y} \times NCV_{biomass} \times (EF_{wf,CO2} + EF_{wf,non\ CO2})$ Source-Monitoring Report for the corresponding SD VISTA period of VCS Project ID 2372	This parameter will be monitored under VCS program for the said project with only the results obtained during corresponding SD VISTA MP being considered in estimations.  No separate sampling or monitoring will be undertaken under SD VISTA program.	At every verification cycle
2	Forest Ecosystem adjoining project implementation area	Increase in Above Ground Biomass	15.2	Fuelwood saved by the project stoves	$B_{y,sav,i,j} = B_{y=1,new,i,j,survey} \times \left( \frac{\eta_{new,i,j}}{\eta_{old,i,j}} - 1 \right)$ Source-Monitoring Report for the corresponding SD VISTA period of VCS Project ID 2372	parameter will be monitored under VCS program for the said project with only the results obtained during corresponding SD VISTA MP being considered in estimations.  No separate sampling or monitoring will be undertaken under SD VISTA program. Not applicable	At every verification cycle

#### 4.4 Net Positive Natural Capital and Ecosystem Services Impacts

By replacing TSF and other traditionally used fuel-inefficient cook stoves with ICS technology the primary project activity, will generate an estimated ~75 tCO<sub>2</sub>e GHG emission reduction per stove over the ten-year project crediting period.

The replacement of TSF with ICS in 0.25 million Malawian households will reduce an estimated ~3.9 tons of woody biomass/stove over the ten-year project crediting period amounting to ~75 tons of woody biomass being save over the project lifetime. The quantitative equations used for estimations of the woody biomass savings have been presented in Appendix E while the estimations can be referred from Monitoring Report for the corresponding SD VISTA period of VCS Project ID 2372.

# APPENDIX

## References

Appendix A: Causal Chain

Appendix B: Beneficiary Brochure (Chichewa – most common language in Malawi)

Appendix C: Beneficiary Brochure (English)

Appendix D: List of Abbreviations

Appendix E: Fuel-wood savings estimates

APPENDIX F: Estimation of PM<sub>2.5</sub> emission from project stoves

## References

1. Krishnapriya, P.P., Chandrasekaran, M., Jeuland, M. and Pattanayak, S.K., 2021. Do improved cookstoves save time and improve gender outcomes? Evidence from six developing countries. *Energy Economics*, 102, p.105456.
2. Bervoets, J., Eveillé, F., & Thulstrup, A. (n.d.). *Improving nutrition through enhanced energy access*. 4. <http://www.fao.org/3/I9967EN/i9967en.pdf>
3. Brouwer, I.D., 1994. Food and fuel: a hidden dimension in human nutrition: a study on the relationship between nutrition security and fuelwood availability in Ntcheu District, Malawi. Brouwer.
4. Makungwa, S.D., Epulani, F. and Woodhouse, I.H., 2013. Fuelwood supply: A missed essential component in a food security equation. *Journal of Food Security*, 1(2), pp.49-51.
5. Clean Cooking Alliance (n.d). Delivering on the Sustainable Development Goals through Clean Cooking. <https://www.cleancookingalliance.org/feature/delivering-on-the-sustainable-development-goals-through-clean-cooking.html>,
6. Amegah, A.K., 2020. Improving Child Survival in Sub-Saharan Africa: Key Environmental and Nutritional Interventions. *Annals of Global Health*, 86(1).
7. Berkeley Air Monitoring Group (2020). *Effects on gender-related outcomes after the introduction of improved cookstoves in rural Zambia*. [http://www.carbonmarket-foundation.org/userfiles/zdk/file/CQC\\_BA\\_Zambia\\_Gender%20Impacts\\_vF2%20copy.pdf](http://www.carbonmarket-foundation.org/userfiles/zdk/file/CQC_BA_Zambia_Gender%20Impacts_vF2%20copy.pdf) 1-28.
8. Das, K., Pradhan. G., & Nonhebel, S. (2019) *Human energy and time spent by women using cooking energy systems: A case study of Nepal*. <https://doi.org/10.1016/j.energy.2019.06.074>
9. Mortimer, K., Ndamala, C. B., Naunje, A. W., Malava, J., Katundu, C., Weston, W., Havens, D., Pope, D., Bruce, N. G., Nyirenda, M., Wang, D., Crampin, A., Grigg, J., Balmes, J., & Gordon, S. B. (2017). A cleaner burning biomass-fuelled cookstove intervention to prevent pneumonia in children under 5 years old in rural Malawi (the Cooking and Pneumonia Study): a cluster randomized controlled trial. *Lancet (London, England)*, 389(10065), 167–175. [https://doi.org/10.1016/S0140-6736\(16\)32507-7](https://doi.org/10.1016/S0140-6736(16)32507-7)
10. Parrish, R., Colbourn, T., Lauriola, P., Leonardi, G., Hajat, S. and Zeka, A., 2020. A Critical Analysis of the Drivers of Human Migration Patterns in the Presence of Climate Change: A New Conceptual Model. *International journal of environmental research and public health*, 17(17), p.6036.
11. Hyder, A. and Behrman, J.R., 2014. Female economic activity in Rural Malawi. *Journal for development and leadership/Nelson Mandela Metropolitan University*. Nelson Mandela Metropolitan University, 3(1), p.1.
12. MALAWI CLIMATE CHANGE FACT SHEET | *Fact Sheet | Malawi | U.S. Agency for International Development*. (2016, September 26). <https://www.usaid.gov/malawi/fact-sheets/malawi-climate-change-fact-sheet>

13. Jeuland, M.A. and Pattanayak, S.K., 2012. Benefits and costs of improved cookstoves: assessing the implications of variability in health, forest and climate impacts. PloS one, 7(2), p.e30338.
  14. Rosenthal, J., Quinn, A., Grieshop, A.P., Pillarisetti, A. and Glass, R.I., 2018. Clean cooking and the SDGs: Integrated analytical approaches to guide energy interventions for health and environment goals. Energy for Sustainable Development, 42, pp.152-159.
- Malawi: Location, map, and cities.* (n.d.). Retrieved May 17, 2021, from <https://www.geodatos.net/en/countries/malawi>
- Vizzuality. (n.d.). *Malawi Deforestation Rates & Statistics | GFW.* Retrieved May 17, 2021, from <https://www.globalforestwatch.org/dashboards>

# APPENDIX A: CAUSAL CHAIN

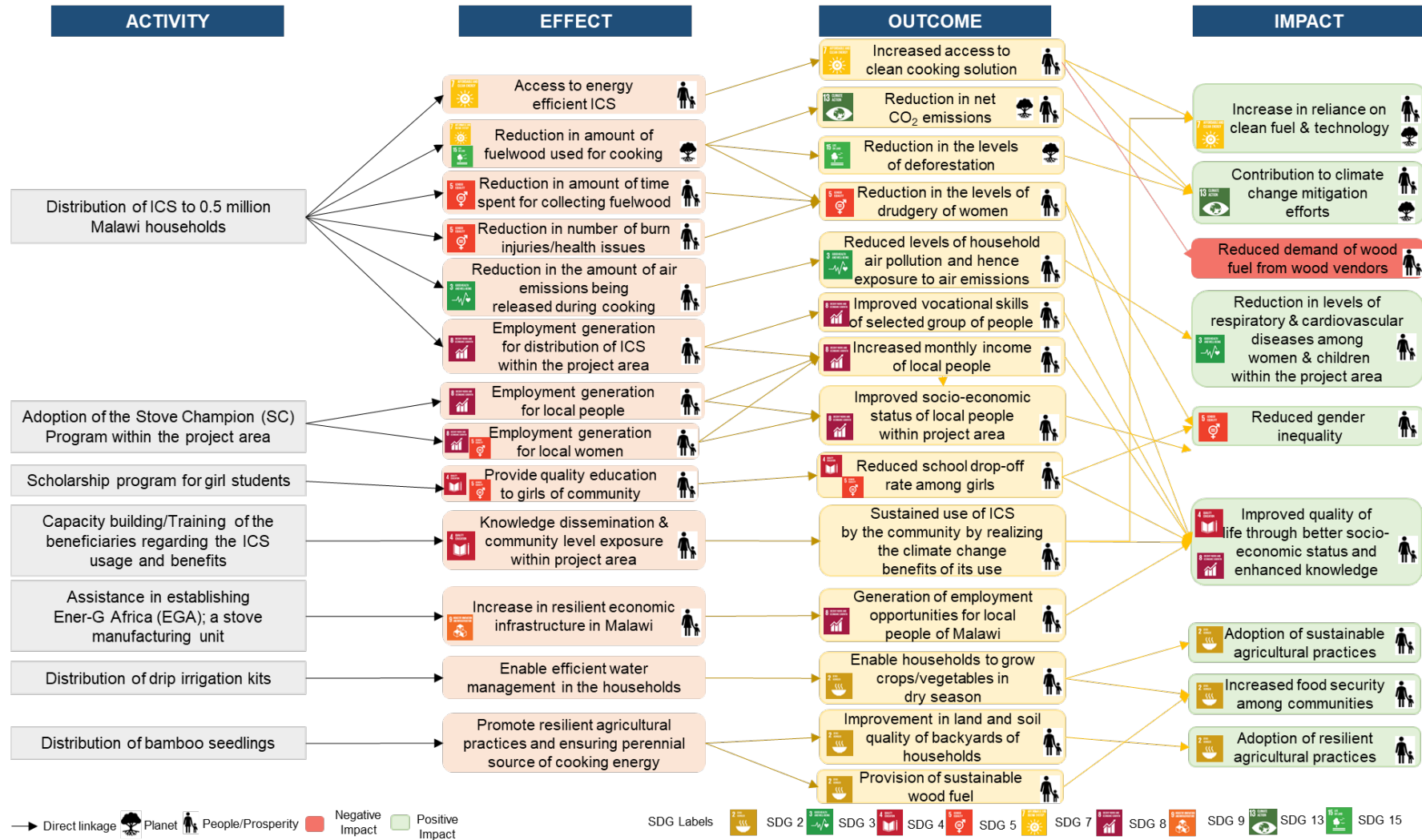

# APPENDIX B: BROCHURE (CHICHEWA)

CQuestCapital

## TLC-CQC ROCKET STOVE - GUIDELINES

### MBAULA

ZOFUNIKILA  
POMANGA  
MBAULA



### NJERWA

ZOFUNIKILA  
POMANGA  
MBAULA



### KUMANGA

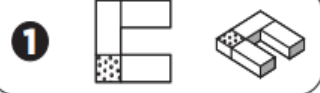

### MORTAR

ZOFUNIKILA  
POMANGA  
MBAULA

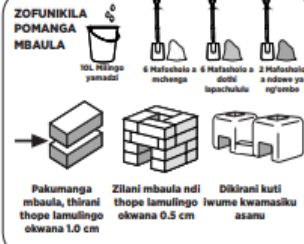

### ZOYENELEZA ZONSE:



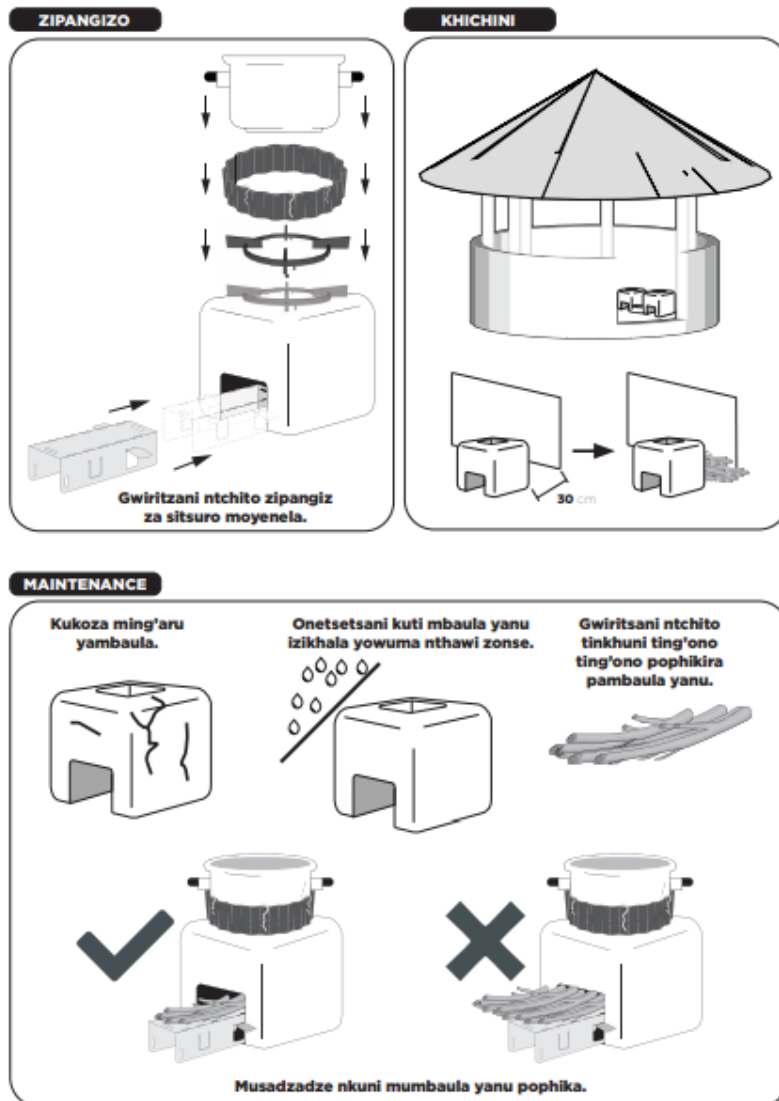

# APPENDIX C: BROCHURE (ENGLISH)

**CQuestCapital**  
**TLC-CQC ROCKET STOVE - GUIDELINES**

**STOVE**

**ITEMS YOU WILL NEED:** 30 Bricks, 6 Halves, 4 Quarters, 10L Water, 6 Shovels: Sand, 6 Shovels: Clay, 2 Shovels: Cow Dung, 1 Brick Mold

**BRICKS**

**ITEMS YOU WILL NEED:** Water, Anthill Clay, Brick Mold

22 cm, 11 cm, 6.5 cm  
 Shade dry for 6 days



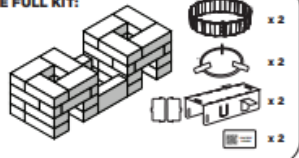

**MORTAR**

**ITEMS YOU WILL NEED:** 10L Water, 6 Shovels: Sand, 6 Shovels: Clay, 2 Shovels: Cow Dung

Apply 1.0 cm of mortar, Cover with 0.5 cm of mortar, Allow to dry for 5 days

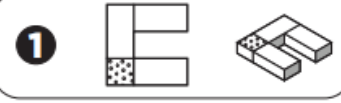
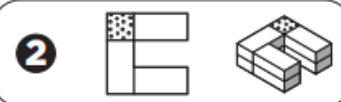
**THE FULL KIT:**  x2, x2, x2, x2

**CONSTRUCTION**

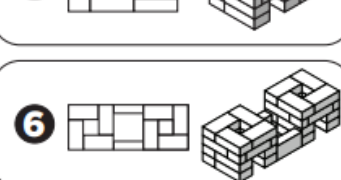
- 
- 
- 
- 
- 
- 

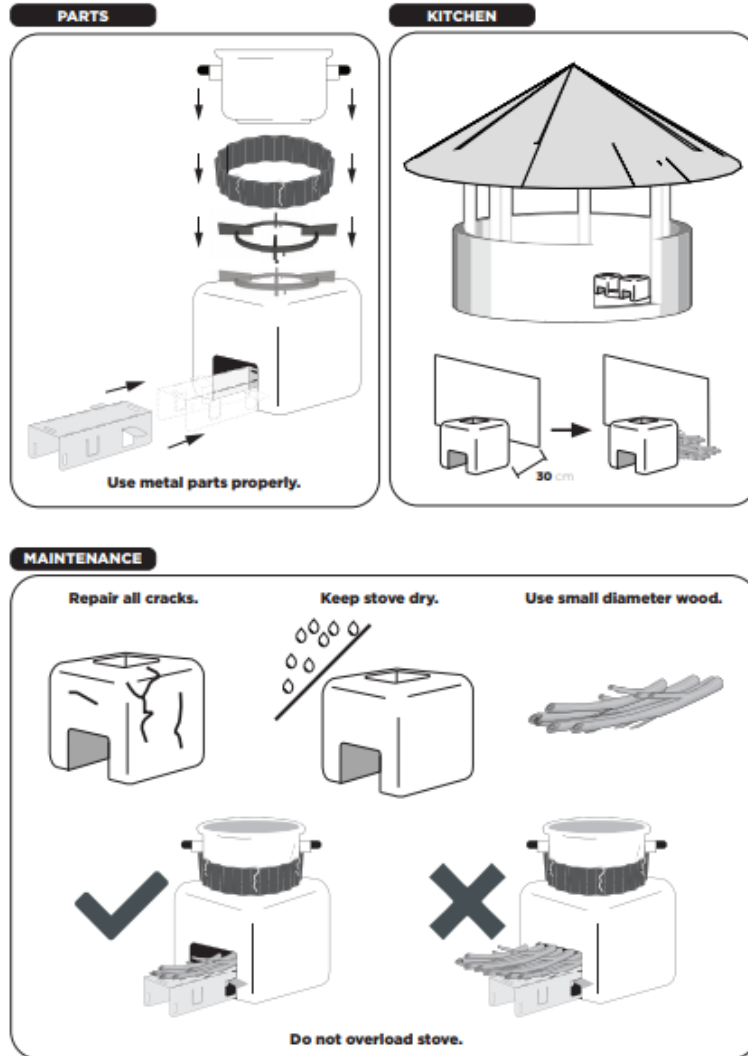

## APPENDIX D: LIST OF ABBREVIATIONS

ADC: Area Development Committee

COPD: Chronic Obstructive Pulmonary Disease

CQC: C-Quest Capital LLC

EGA: Ener-G-Africa

GP: Grouped Project

GVH: Group Village Headperson

HAP: Household Air Pollution

HP: Health Promoters

ICS: Improved Cookstoves

ILO: International Labour Organisation

LSC: Local Stakeholder Consultation

PM<sub>2.5</sub>: Particulate Matter

SC: Stove Champions

SDG: Sustainable Development Goals

TA: Traditional Authority

TLCRS: TLC Rocket Stoves

TSF: Three-stone fire stove

VCS: Voluntary Carbon Standard

VSL: Village Savings and Loans Program

# APPENDIX E: FUEL-WOOD SAVINGS ESTIMATES

Equation used for wood saving estimation:

$$B_{y,sav,i,j} = B_{y=1,new,i,j,survey} \times \left( \frac{\eta_{new,i}}{\eta_{old}} - 1 \right)$$

Where:

$\eta_{old,i,j}$  = Efficiency of baseline devices that are replaced by project devices of type  $i$  (fraction)

$\eta_{new,i,j}$  = Efficiency of project device of type  $i$  (fraction)

$B_{y=1,new,i,j,survey}$  = Quantity of woody biomass used per project device of type  $i$  from batch  $j$  (tonnes)

# APPENDIX F: ESTIMATION OF PM<sub>2.5</sub> EMISSION FROM PROJECT STOVES

From second year onwards PM<sub>2.5</sub> exposure for project stoves shall be calculated as a function of efficiency drop as several studies point to decrease in PM<sub>2.5</sub> levels with increase in stove efficiency and vice versa.

The efficiency drop is calculated using following equation

$$\eta_{new\ y,i,j} = \eta_p \times DF_n^{(y-1)} \times 0.94$$

Where,

$\eta_{new\ y,i,j}$  = Efficiency of project stove (fraction) for cookstove type i, batch j for year y;

$\eta_p$  = Efficiency of project stove (fraction) at the start of project activity;

$DF_n^{(y-1)}$  = Discount factor to account for efficiency loss of project cookstove per year of operation (fraction). This value may be based on actual monitoring or based on manufacturer's declaration on expected loss in efficiency or through publicly available literature on relevant industry standards Alternatively default value of 0.99 efficiency loss per year can be considered;

0.94 = Adjustment factor to account for uncertainty related to project cookstove efficiency test

Hence, the corresponding PM<sub>2.5</sub> exposure shall be calculated as

$$EX_{PM_{2.5},y,i,j} = EX_{PM_{2.5},p} \times \left( \frac{\eta_p}{\eta_{new\ y,i,j}} \right)$$

Where

$EX_{PM_{2.5},y,i,j}$	=	PM <sub>2.5</sub> exposure in year y for project devices of type i and batch j
$EX_{PM_{2.5},p}$	=	PM <sub>2.5</sub> exposure at the start of the intervention
$\eta_{new\ y,i,j}$	=	Stove efficiency in year y
$\eta_p$	=	Stove efficiency at the start of project activity