

MRMPL WIND POWER PROJECT



Document Prepared By Infinite Solutions

Project Title	MRMPL Wind Power Project
Version	01
Date of Issue	23-July-2018
Monitoring Period	01 st May 2012 to 30 th April 2018
Prepared By	Infinite Solutions
Contact	Address: 611, Chetak Centre Main, 12/2 R.N.T. Marg, Indore, MP – 452001 Landline No.: 0731-4050174 Email: jimmy@infisolutions.org Website: www.infisolutions.org

Table of Contents

1	Project Details	4
1.1	Summary Description of the Project and its Implementation Status	4
1.2	Sectoral Scope and Project Type	5
1.3	Project Proponent	5
1.4	Other Entities Involved in the Project	5
1.5	Project Start Date	5
1.6	Project Crediting Period	6
1.7	Project Scale and Estimated GHG Emission Reductions or Removals	6
1.8	Description of the Project Activity	6
1.9	Project Location	6
1.10	Conditions Prior to Project Initiation	7
1.11	Compliance with Laws, Statutes and Other Regulatory Frameworks	8
1.12	Ownership and Other Programs	8
1.12.1	Project Ownership	8
1.12.2	Emissions Trading Programs and Other Binding Limits	8
1.12.3	Other Forms of Environmental Credit	8
1.12.4	Participation under Other GHG Programs	8
1.12.5	Projects Rejected by Other GHG Programs	9
1.13	Additional Information Relevant to the Project	9
2	Application of Methodology	10
2.1	Title and Reference of Methodology	10
2.2	Applicability of Methodology	10
2.3	Project Boundary	11
2.4	Baseline Scenario	12
2.5	Additionality	12
2.6	Methodology Deviations	12
3	ESTIMATED GHG Emission Reductions and Removals	12
3.1	Baseline Emissions	12
3.2	Project Emissions	12
3.3	Leakage	12
3.4	Estimated Net GHG Emission Reductions and Removals	12
4	Monitoring	13
4.1	Data and Parameters Available at Validation	13
4.2	Data and Parameters Monitored	14
4.3	Monitoring Plan	15
5	Safeguards	17
5.1	No Net Harm	17
5.2	Environmental Impact	17
5.3	Local Stakeholder Consultation	17
5.4	Public Comments	17
6	ACHIEVED GHG EMISSION REDUCTIONS AND REMOVALS	17
6.1	Data and Parameters Monitored	17
6.2	Baseline Emissions	19
6.3	Project Emissions	19

6.4 Leakage 19

6.5 Net GHG Emission Reductions and Removals..... 19

APPENDIX X: <title of appendix> 21

1 PROJECT DETAILS

1.1 Summary Description of the Project and its Implementation Status

The project sponsor is Modern Road Makers Pvt. Ltd. (herein referred to as MRMPL). It is a subsidiary of IRB Infrastructure Developers Limited (IRBIDL). It is involved in the construction, operation and maintenance of roads through various infrastructure projects in the road sector and is one of the major road developers in India.

The project is the generation of electricity from wind power by installation of 16 Wind Turbine Generators (WTG) at Jaisalmer, Rajasthan. Each WTG has an installed capacity of 1.25 MW. The total installed capacity of the project is 20 MW. The purpose of the project is to produce power from clean source and to reduce the dependence on fossil fuels for energy requirements. Project proponent has signed a power purchase agreement (PPA) with “Jodhpur Vidyt Vitran Nigam Limited” (JVVNL) to export the electricity to local grid.

The project displaces electricity from the grid (North East West North East (NEWNE) grid, India). This helps in significant reduction of GHG emissions as the NEWNE Grid is mostly dependent on fossil fuel generated electricity.

The monitoring period is from 01st May 2012 to 30th April 2018. The total GHG emission reductions or removals generated in this monitoring period are 1,29,672 tCO₂.

Scenario existing prior to the implementation of project activity:

The scenario existing prior to the implementation of the project activity, is electricity delivered to the grid by the project activity that would have otherwise been generated by the operation of grid-connected power plants and by the addition of new generation sources, as reflected in the combined margin (CM) calculations described in the “Tool to calculate the emission factor for an electricity system”.

Baseline Scenario:

As per the applicable methodology, a Greenfield power plant is defined as “a new renewable energy power plant that is constructed and operated at a site where no renewable energy power plant was operated prior to the implementation of the project activity”.

As the project activity falls under the definition of a Greenfield power plant, the baseline scenario as per paragraph 24 of Section 5.2.1 of applied methodology is the following:

If the project activity is the installation of a Greenfield power plant, the baseline scenario is electricity delivered to the grid by the project activity would have otherwise been generated by the operation of grid-connected power plants and by the addition of new generation sources, as reflected in the combined margin (CM) calculations described in the “Tool to calculate the emission factor for an electricity system”.

Hence, pre-project scenario and baseline scenario are the same.

1.2 Sectoral Scope and Project Type

Project type: Renewable energy projects

Sectoral Scope: 1- Energy Industries (renewable/non-renewable sources).

Project Type : I - Renewable Energy Projects

Methodology : ACM0002: Grid-connected electricity generation from renewable sources - Version 10

The project is not a grouped project activity.

1.3 Project Proponent

Organization name	Modern Road Makers Pvt Ltd.
Contact person	A. D. Yadav
Title	Chief Financial Officer
Address	A – 201, Universal Business Pard, 2 nd Floor, Kamani Oil Mill Road, Chandivli Estate, Andheri (East)
Telephone	+91 22 6733 5959
Email	info@irb.co.in

1.4 Other Entities Involved in the Project

Organization name	Infinite Solutions
Role in the project	Project Consultant
Contact person	Jimmy Sah
Title	Head – Sustainability
Address	611, Chetak Centre Main, 12/2 RNT Marg Indore
Telephone	+91-96441-30430
Email	jimmy@infisolutions.org

1.5 Project Start Date

Project Start Date: 28-September-2008

The project start date is the date on which first 5 MW of the project was commissioned.

1.6 Project Crediting Period

Crediting Period Start date: 01-May-2012

Crediting Period End date: 30-April-2022

The project activity adopts renewable crediting period of 10 years period which can be renewed for 2 times.

1.7 Project Scale and Estimated GHG Emission Reductions or Removals

As the estimated annual average GHG emission reductions or removal per year is 32,788 tCO₂e which is less than 300,000 tonnes of CO₂e per year, thus the project falls in the category of Project.

Project Scale	
Project	√
Large project	

Year	Estimated GHG emission reductions or removals (tCO ₂ e)
Year 1	32,788
Year 2	32,788
Year 3	32,788
Year 4	32,788
Year 5	32,788
Year 6	32,788
Year 7	32,788
Year 8	32,788
Year 9	32,788
Year 10	32,788
Total estimated ERs	3,27,880
Total number of crediting years	10
Average annual ERs	32,788

1.8 Description of the Project Activity

Not Applicable as project is registered under CDM.

1.9 Project Location

The project activity is located at villages Mudari, Ganesh ki Dhani, Dhava and Dedha in the district of Jaisalmer, Rajasthan. The nearest railway station and airport to reach the site is the town of Jaisalmer located approximately 30 kms from the project site. The coordinates of the WTGs have been tabled below:

Sr No.	Location No.	Latitude	Longitude
1	R060	N 260 48' 45.8"	E 700 44' 16.3"
2	R061	N 260 48' 36.8"	E 700 44' 26.1"
3	R078	N 260 49' 15.4"	E 700 51' 35.4"
4	R007	N 260 48' 58.4"	E 700 51' 37.2"
5	R008	N 260 48' 41.7"	E 700 51' 39.4"
6	R063	N 260 48' 54.6"	E 700 43' 33.2"
7	R064	N 260 48' 45.1"	E 700 43' 43.5"
8	R069	N 260 48' 36.8"	E 700 43' 23.5"
9	R070	N 260 48' 27.3"	E 700 43' 33.8"
10	R071	N 260 48' 17.7"	E 700 43' 44.2"
11	R072	N 260 48' 08.2"	E 700 43' 54.5"
12	R073	N 260 47' 58.6"	E 700 44' 04.9"
13	R074	N 260 47' 49.1"	E 700 44' 15.2"
14	R016	N 260 49' 21.4"	E 700 49' 30.9"
15	R062	N 260 48' 25.3"	E 700 44' 37.1"
16	R067	N 260 48' 00.3"	E 700 44' 34.7"

The map of the project location is shown below:

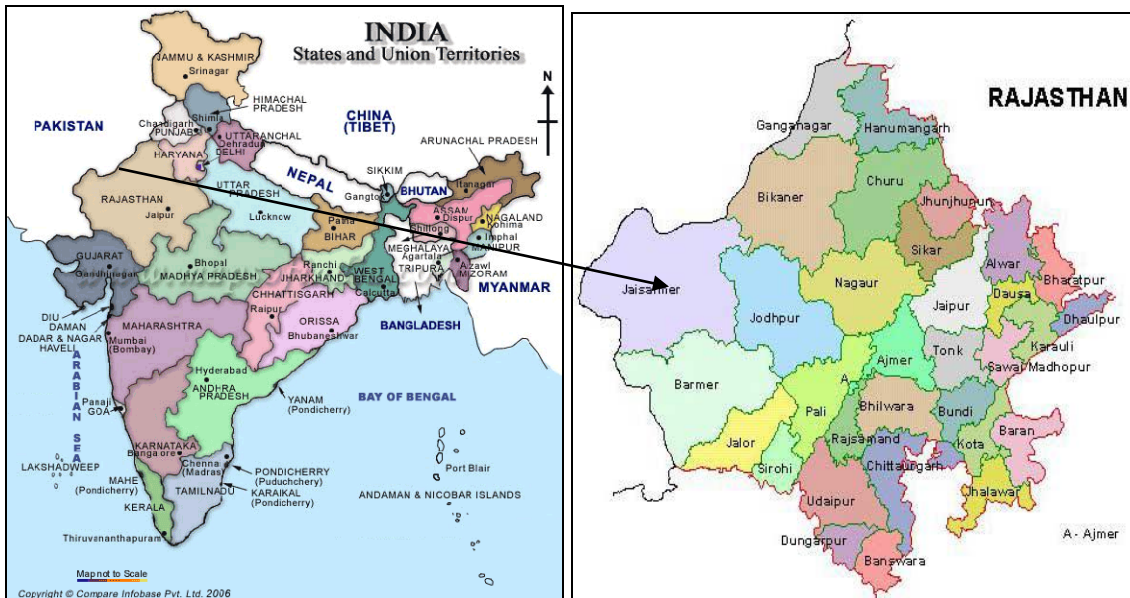

1.10 Conditions Prior to Project Initiation

This is a Greenfield project. In the Pre- project scenario the equivalent amount of electricity delivered to the grid by the project activity, would have otherwise been generated by the operation of grid-connected fossil fuel based power plants and by the addition of new generation sources.

As the project activity is the installation of a new grid-connected wind power plant/unit, as per ACM0002, Version 10, the baseline scenario is the following:

Electricity delivered to the grid by the project activity would have otherwise been generated by the operation of grid-connected power plants and by the addition of new generation sources, as reflected in the combined margin (CM) calculations described in the “Tool to calculate the emission factor for an electricity system” (Version 02) described step wise in CDM registered PDD.

Please refer CDM registered PDD. The web link for the same is mentioned below:

<https://cdm.unfccc.int/Projects/DB/LRQA%20Ltd1278588174.29/view>

1.11 Compliance with Laws, Statutes and Other Regulatory Frameworks

Not Applicable.

1.12 Ownership and Other Programs

1.12.1 Project Ownership

The Project is owned by Modern Road Makers Pvt. Ltd., hence it possess right of use of ER credits. The Ownership is demonstrated through the following documents.

1. Commissioning certificates for WTGs in the name Modern Road Makers Pvt. Ltd. issued by state nodal agencies.
2. Power Purchase Agreement with Jodhpur Vidyut Vitran Nigam Limited” (JVVNL) for sale of electricity by the Modern Road Makers Pvt. Ltd.

1.12.2 Emissions Trading Programs and Other Binding Limits

The project is registered under CDM mechanism, project id 3839. Project Proponent has submitted undertaking that they will not claim same emission reductions of the project from CDM and VCS for the same monitoring period.

The emission reductions from the VCS monitoring period would not be used for compliance with emission trading program to meet binding limits on GHG emissions.

1.12.3 Other Forms of Environmental Credit

The Project is registered with as CDM project, no. 3839. The Project Proponent has submitted undertaking for not availing other forms of environmental credit for the same monitoring period under consideration.

1.12.4 Participation under Other GHG Programs

The project is registered under CDM mechanism, project id 3839. Project Proponent has submitted undertaking that they will not claim same emission reductions of the project from CDM and VCS for the same monitoring period.

The project has undergone CDM verification till 30-04-2012, the current monitoring period is from 01/05/2012 to 31/05/2018. The Project Proponent has submitted undertaking for not availing

other forms of environmental credit as well participation in other GHG programs for the same monitoring period under consideration.

1.12.5 Projects Rejected by Other GHG Programs

The Project is not rejected by other GHG programs.

1.13 Additional Information Relevant to the Project

Eligibility Criteria

The project does not fall under AFOLU category, hence not applicable

Leakage Management

Project does not involve any leakage emissions other than methodology requirement for wind power project. Hence there are no any extra Leakage Management Plan and risk mitigation measures are required.

Commercially Sensitive Information

No commercially sensitive information has been excluded from the public version of the project description.

Sustainable Development

The project proponent has considered the sustainable development of the region due to the project activity. Ministry of Environment and Forests, Govt. of India has stipulated the following indicators for sustainable development in the interim approval guidelines for CDM projects:

Social well-being:

- The project activity contributes towards local socio-economic development around its area of operation through provision of employment opportunities (direct and indirect) for local population.
- It contributes towards improving the India's power deficit situation by contributing to the power grid and making power accessible to more people.

Environmental well-being:

- The project activity causes sustenance and improvement in regional air quality by avoiding commonly used fossil fuels for power generation. It thereby, also, results in maintenance of the ecosystem and human health due to avoidance in the use of GHG emissive fuels such as coal.
- It also leads to conservation of natural resources such as coal, oil etc.

Economic well-being:

- By providing employment opportunities, this project activity leads to development in the local economy.

- Through bringing in revenue to India through CDM process, it demonstrates how certain real and perceived financial barriers can be overcome for implementing clean energy measures.

Technological well-being:

- The successful implementation of the project activity will result in encouraging the use of cleaner technology. This will lead to replacement of the non-eco-friendly sources of power generation like thermal energy which are the major sources of power in the country.

Further Information

There are no information or incidents that will have bearing on the eligibility of the project, the net GHG emission reductions or removals, or the quantification of the project’s net GHG emission reductions or removals.

2 APPLICATION OF METHODOLOGY

2.1 Title and Reference of Methodology

ACM0002: Grid-connected electricity generation from renewable sources - Version 10

2.2 Applicability of Methodology

The project is registered under CDM mechanism, project id 3839. The Methodology ACM0002 version 10, is applicable to the project activity. The applicability criteria are met in the following way:

Applicability Criteria	Project Scenario
The project activity is the installation, capacity addition, retrofit or replacement of a power plant/unit of one of the following types: hydro power plant/unit (either with a run-of-river reservoir or an accumulation reservoir), wind power plant/unit, geothermal power plant/unit, solar power plant/unit, wave power plant/unit or tidal power plant/unit	The project activity is the installation of a new wind power plant unit. Hence it fulfils the applicability criteria.
In the case of capacity additions, retrofits or replacements: the existing plant started commercial operation prior to the start of a minimum historical reference period of five years, used for the calculation of baseline emissions and defined in the baseline emission section, and no capacity expansion or retrofit of the plant has been undertaken between the start of this minimum historical reference period and the implementation of the project activity	The project activity is a newly installed wind power plant and does not involve capacity additions, retrofits or replacements.
In case of hydro power plants, one of the following conditions must apply: <ul style="list-style-type: none"> • The project activity is implemented in an 	The proposed project activity is does not involve any hydro plants. It’s a wind power installation and hence this condition does not apply to this particular project activity.

<p>existing reservoir, with no change in the volume of reservoir; or</p> <ul style="list-style-type: none"> • The project activity is implemented in an existing reservoir, where the volume of reservoir is increased and the power density of the project activity, as per definitions given in the Project Emissions section, is greater than 4 W/m²; or • The project activity results in new reservoirs and the power density of the power plant, as per definitions given in the Project Emissions section, is greater than 4 W/m². 	
---	--

2.3 Project Boundary

As per the methodology, “the spatial extent of the project boundary includes the project site and all power plants connected physically to the electricity system that the project power plant is connected to.”

Source		Gas	Included?	Justification/Explanation
Baseline	CO2 emissions from electricity generation in fossil fuel fired power plants that is displaced due to the project activity	CO ₂	Yes	Main emission source
		CH ₄	No	Minor emission source
		N ₂ O	No	Minor emission source
		Other	No	-
Project	For geothermal power plants, fugitive emissions of CH ₄ and CO ₂ from non-condensable Gases contained in geothermal steam.	CO ₂	No	The present project activity is a greenfield wind power project. Hence, not relevant
		CH ₄	No	
		N ₂ O	No	
		Other	No	
	CO ₂ emissions from combustion of fossil fuels for electricity generation in solar thermal power plants and geothermal power plants	CO ₂	No	The present project activity is a greenfield wind power project. Hence, not relevant
		CH ₄	No	
		N ₂ O	No	
		Other	No	
	For hydro power	CO ₂	No	The present project activity is a

Source		Gas	Included?	Justification/Explanation
	plants, emissions of CH ₄ from the reservoir.	CH ₄	No	greenfield wind power project. Hence, not relevant
		N ₂ O	No	
		Other	No	

2.4 Baseline Scenario

Please refer to section B.4 of the PDD of UNFCCC registered CDM project with Ref No: 3839. The web link for the same is given below:

<https://cdm.unfccc.int/Projects/DB/LRQA%20Ltd1278588174.29/view>

2.5 Additionality

Please refer to section B.5 of the PDD of UNFCCC registered CDM project with Ref No: 3839. The web link for the same is given below:

<https://cdm.unfccc.int/Projects/DB/LRQA%20Ltd1278588174.29/view>

2.6 Methodology Deviations

The project activity does not involve any methodology deviations. Hence this section is not applicable.

3 ESTIMATED GHG EMISSION REDUCTIONS AND REMOVALS

3.1 Baseline Emissions

Please refer to section B.6.3 of the PDD of UNFCCC registered CDM project with Ref No: 3839. The web link for the same is given below:

<https://cdm.unfccc.int/Projects/DB/LRQA%20Ltd1278588174.29/view>

3.2 Project Emissions

Please refer to section B.6.3 of the PDD of UNFCCC registered CDM project with Ref No: 3839. The web link for the same is given below:

<https://cdm.unfccc.int/Projects/DB/LRQA%20Ltd1278588174.29/view>

3.3 Leakage

Please refer to section B.6.3 of the PDD of UNFCCC registered CDM project with Ref No: 3839. The web link for the same is given below:

<https://cdm.unfccc.int/Projects/DB/LRQA%20Ltd1278588174.29/view>

3.4 Estimated Net GHG Emission Reductions and Removals

Please refer to section B.6.3 of the PDD of UNFCCC registered CDM project with Ref No: 3839. The web link for the same is given below:

<https://cdm.unfccc.int/Projects/DB/LRQA%20Ltd1278588174.29/view>

4 MONITORING

4.1 Data and Parameters Available at Validation

Not Applicable

Data / Parameter	$EF_{Grid,OM,y}$
Data unit	tCO ₂ /MWh
Description	Weighted Average Simple Operating margin of the grid
Source of data	Central Electricity Authority database (Version 4.0)
Value applied:	1.0086
Justification of choice of data or description of measurement methods and procedures applied	The value has been sourced from Central Electricity Authority database (Version 4.0)
Purpose of the data	The value has been used form the Central Electricity Authority (CEA) database (Version 4.0, dated 1st September 2008) for the calculation of the Baseline emissions
Comments	-

Data / Parameter	$EF_{Grid,BM,y}$
Data unit	tCO ₂ /MWh
Description	Build Margin of the grid.
Source of data	Central Electricity Authority database (Version 4.0)
Value applied:	0.5977
Justification of choice of data or description of measurement methods and procedures applied	The value has been sourced from Central Electricity Authority database (Version 4.0)
Purpose of the data	The value has been used form the Central Electricity Authority (CEA) database (Version 4.0, dated 1st September 2008) for the calculation of the Baseline emissions.
Comments	-

Data / Parameter	$EF_{Grid,CM,y}$
------------------	------------------

Data unit	tCO ₂ /MWh
Description	Combined Margin emission factor of the grid
Source of data	Central Electricity Authority database (Version 4.0)
Value applied:	0.9058
Justification of choice of data or description of measurement methods and procedures applied	The value has been sourced from Central Electricity Authority database (Version 4.0)
Purpose of the data	This value is used for the calculation of the Baseline emissions
Comments	-

4.2 Data and Parameters Monitored

Data / Parameter	EG _y
Data unit	MWh
Description	Total Electricity Exported to the grid
Source of data	Credit Notes from the state electricity utility
Description of measurement methods and procedures to be applied	<p>Monitoring: Electrical Energy Meters which are electronic tri-vector meters of accuracy class 0.2 (Main & Check meters)</p> <p>Data type: Measured and calculated</p> <p>Archiving: Paper & Electronic</p> <p>Responsibility: The O&M site-in-charge is responsible for the regular recording of data.</p>
Frequency of monitoring/recording	Recording: Monthly
Value monitored:	43,313,383
Monitoring equipment	Electrical Energy Meters which are electronic tri-vector meters of accuracy class 0.2 (Main & Check meters)
QA/QC procedures to be applied	Meter calibration is conducted annually
Purpose of the data	Calculation of baseline emissions
Calculation method	As described in section 2.1 of this document
Comments	Data archived: The data will be kept for two years after the end of the crediting period or the last issuance of VERs for this project activity, whichever occurs later.

Data / Parameter	EC _y
Data unit	MWh
Description	Total Electricity Import from Grid
Source of data	Credit Notes from the state electricity utility
Description of measurement methods and procedures to be applied	<p>Monitoring: Electrical Energy Meters which are electronic tri-vector meters of accuracy class 0.2 (Main & check meters)</p> <p>Data type: Measured and calculated</p> <p>Archiving: Paper and Electronic</p>

	<p>Recording Frequency: Daily</p> <p>Responsibility: The O&M site-in-charge is responsible for the regular recording of data.</p>
Frequency of monitoring/recording	Daily
Value monitored:	126,804
Monitoring equipment	Electrical Energy Meters which are electronic tri-vector meters of accuracy class 0.2 (Main & check meters)
QA/QC procedures to be applied	Meter calibration is conducted annually
Purpose of the data	Calculation of baseline emissions
Calculation method	As described in section 2.1 of this document
Comments	Data archived: The data will be kept for two years after the end of the crediting period or the last issuance of CERs for this project activity, whichever occurs later.

4.3 Monitoring Plan

Monitoring Process at Rajasthan

Project participant has implemented 20 MW Wind energy power generation project. Power generation using renewable energy like wind power is eligible for carbon credit benefits. Following is a monitoring plan for project activity:

Organizational Structure:

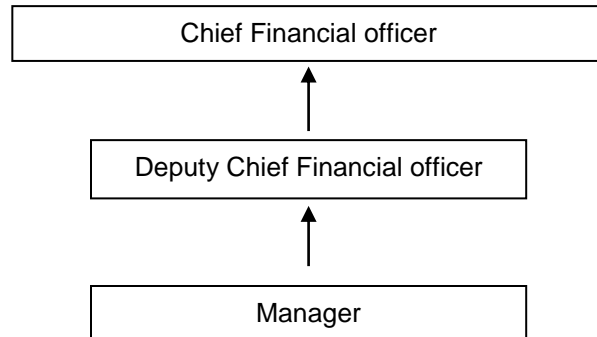

Responsibility:

Analysis of power generation reports, performance report and monthly meter reading is handled by project proponents on regular basis. The data collection on daily basis is done by O&M team contracted by project proponent. An automated generation report is sent to the manager. The manager maintains the generation reports.

The Deputy chief Financial officer is assisted by the manager on the project. He is responsible to plan and allocate the annual budget for operation, estimation of the likely operating cost, electricity dispatch, organizing third party contractors, revenue collection etc. The deputy CFO reports to the chief financial officer who is responsible for the overall project management.

O&M team is responsible for preventive maintenance, handling emergency situations and improvement measures. O&M team ensures that joint monthly reading, issuance of credit notes and meter testing on regular basis.

Data Monitoring:

The delivered energy is metered by the authorities of JVVNL in the presence of representatives of the technology supplier at the substation at Soda Mada. Metering equipment used is electronic tri-vector meters. The metering equipment is maintained in accordance with electricity standards. The monthly meter readings at the project sites (controller reading) and the receiving station are taken simultaneously and jointly by the parties. The controller readings of the Wind mills are also recorded by the technology supplier by a Central Monitoring system installed at the wind site. Daily and monthly generation reports are sent to MRMPL.

The single line diagram for the metering may be represented as follows:

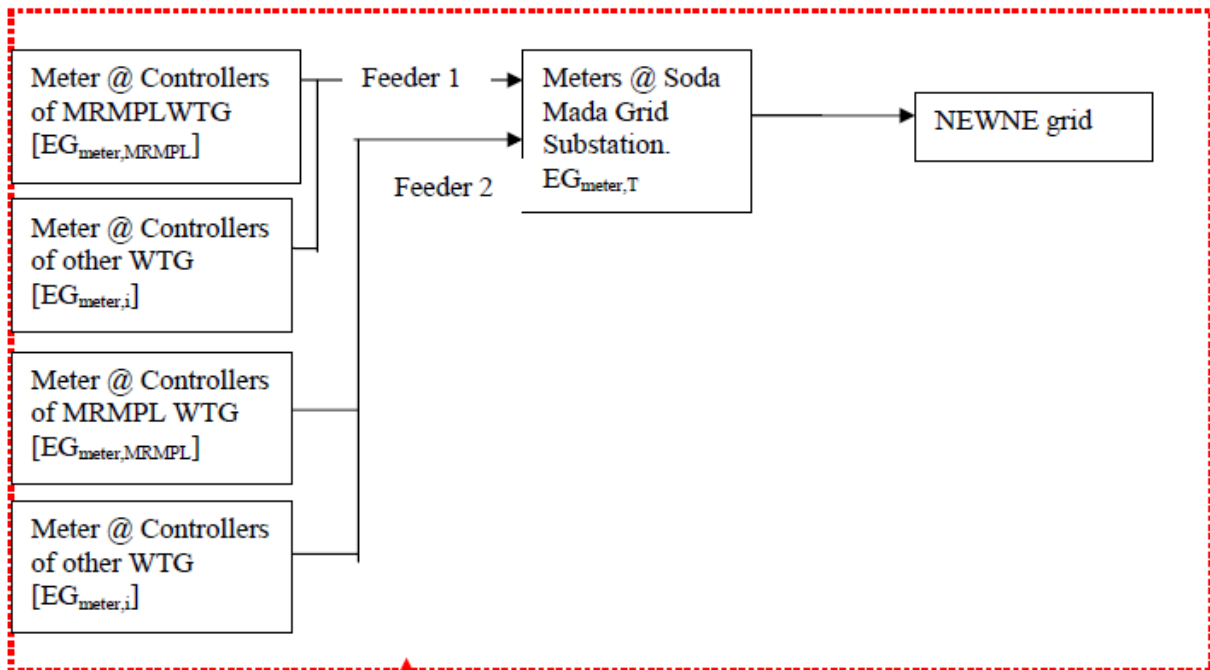

All the Main and Check meters are tested for accuracy annually with reference to a portable standard meter. As the instruments are calibrated and marked at regular intervals, the accuracy of measurement can be assured at all times. To ensure accurate and continuous monitoring, MRMPL has a standby meter, calibrated by an authorized agency.

The allocation of electricity is executed as per the following procedure:

1. Enter the value of electricity received from meter at the controller (kWh).
2. Enter the value of electricity supplied to meter at the controller (kWh).
3. Take the difference of electricity received and supplied to meter at the controller (kWh)
4. Take the difference of electricity as per the above steps 1 to 3 for each of the WTGs (of owner i) connected to the feeder of the MRMPL WTG. [EG_{meter,i}]
5. Take the sum of all the controller readings as calculated in Step 4. [Σ EG_{meter,i}]

6. Divide individual difference by total calculated as per step 5 and multiply by 100 to find % allocation for each of the WTG of MRMPL.

$[\text{EGmeter MRMPL} / \sum \text{EGmeter},i) \times 100]$

7. Enter the value of electricity received from the feeder at the substation (kWh).

8. Enter the value of electricity supplied to the feeder at the substation (kWh).

9. Take the difference of electricity received and supply to meter at the substation. (kWh)

$[\text{EGmeter},T]$

10. Multiply the value calculated as per step 9 by % allocation calculated as per step 6 to calculate the net electricity export allocated to the WTGs of MRMPL connected to the feeder.

$[\text{EGnet},\text{MRMPL},$

i.e., EGy and ECy]

The project owner uses the credit notes sent by state electricity board for respective the WTGs at different locations. The cumulative power supplied to grids is tabulated and multiplied by respective Grid Emission Factor to calculate number of VER.

5 SAFEGUARDS

5.1 No Net Harm

There are no negative environmental and/or negative socio-economic impacts due to the project.

5.2 Environmental Impact

Not Applicable

5.3 Local Stakeholder Consultation

Discussions with Local stakeholders is being carried out at periodic intervals. There are no negative comments received for the project. In line with VCS requirements the following process has been implemented to receive comments from local stakeholders as well as communicate with them at periodic intervals. The project shall be listed at VCS website to invite comments.

5.4 Public Comments

The project shall be listed for 30 day period. In case any comments are received they shall be incorporated during the validation.

6 ACHIEVED GHG EMISSION REDUCTIONS AND REMOVALS

6.1 Data and Parameters Monitored

Data / Parameter	EG _y
Data unit	MWh
Description	Total electricity exported to grid
Source of data	Credit notes from the state electricity utility
Description of measurement methods and procedures applied	Responsibility: The O&M site-in-charge shall be responsible for the regular recording of data.
Frequency of monitoring/recording	Monthly
Value applied:	43,313,383
Monitoring equipment	Monitoring: Electrical Energy Meters which are electronic tri-vector meters of accuracy class 0.2 (Main & Check meters) Data type: Measured & Calculated Archiving: Paper & Electronic
QA/QC procedures applied	Meter calibration shall be conducted annually.
Purpose of data	Calculation of baseline emissions
Calculation method	<i>The calculation procedure is detailed under section 4.3 above</i>
Comments	Data archived: The data will be kept for two years after the end of the crediting period or the last issuance of VERs for this project activity, whichever occurs later.

Data / Parameter	EC _y
Data unit	MWh
Description	Total Electricity Import from Grid
Source of data	Credit Notes from the state electricity utility
Description of measurement methods and procedures to be applied	Monitoring: Electrical Energy Meters which are electronic tri-vector meters of accuracy class 0.2 (Main & check meters) Data type: Measured and calculated Archiving: Paper and Electronic Recording Frequency: Daily Responsibility: The O&M site-in-charge is responsible for the regular recording of data.
Frequency of monitoring/recording	Daily
Value monitored:	126,804
Monitoring equipment	Electrical Energy Meters which are electronic tri-vector meters of accuracy class 0.2 (Main & check meters)
QA/QC procedures to be applied	Meter calibration is conducted annually
Purpose of the data	Calculation of baseline emissions
Calculation method	As described in section 2.1 of this document
Comments	Data archived: The data will be kept for two years after the end of

	the crediting period or the last issuance of CERs for this project activity, whichever occurs later.
--	--

6.2 Baseline Emissions

Baseline emissions are calculated by multiplying the Net electricity exported to the grid with net baseline emission factor, as per the CDM approved methodology.

$BE_y = \text{Baseline Emission Factor (EF}_{\text{grid, CM, y}}) \times \text{Net electricity supplied to Regional Grid (EG}_{\text{facility, y}})$

Where,

$BE_y = \text{Baseline Emissions (tons/year)}$

$EG_{\text{facility, y}} = \text{Quantity of net electricity generation supplied by the project plant/unit to the grid in year y (MWh/yr)}$

$EF_{\text{grid, CM, y}} = \text{Combined margin CO}_2 \text{ emission factor for grid connected power generation in year y calculated using the latest version of the "Tool to calculate the emission factor for an electricity system" (tCO}_2\text{/MWh)}$

The Baseline emission factor is calculated in the registered CDM PDD as per **"Tool to calculate the emission factor for an electricity system", Version 02, EB 50**.

Thus, as per the CDM PDD, the calculated Baseline emission factor is $EF_{\text{grid, CM, y}} = 0.9058 \text{ tCO}_2\text{/MWh}$

The Baseline Emission Factor is fixed.

The net export from the project activity is 143,162 MWh. Hence the baseline emissions are calculated as below:

$$\begin{aligned} \text{Baseline Emissions (BE}_y) &= 0.9058 * 143,162 \\ &= 129,672 \text{ tCO}_2 \end{aligned}$$

6.3 Project Emissions

The project uses wind energy only for power generation which leads to zero net GHG on-site emissions. Hence there is no net emission within the project boundary. Hence, $PE_y = 0$.

6.4 Leakage

The project proponents have identified no anthropogenic greenhouse gases by sources outside the project boundary that are significant, measurable and attributable to the project activity. Hence, no leakage is considered from the project activity. Hence, $LE_y = 0$

6.5 Net GHG Emission Reductions and Removals

The emission reductions are calculated as per the equation:

$$ER = BE_y - PE_y - LE_y$$

ER – Emission Reduction (tCO₂/year)

BE_y - Baseline Emissions (tCO₂/year)

PE_y – Project Emissions (tCO₂/year)

LE_y - Leakage Emissions (tCO₂/year)

ER = BE_y – PE_y – LE_y

Year	Baseline emissions or removals (tCO ₂ e)	Project emissions or removals (tCO ₂ e)	Leakage emissions (tCO ₂ e)	Net GHG emission reductions or removals (tCO ₂ e)
2012	20,326	-	-	20,326
2013	21,507	-	-	21,507
2014	21,340	-	-	21,340
2015	18,328	-	-	18,328
2016	22,317	-	-	22,317
2017	21,473	-	-	21,473
2018	4,381	-	-	4,381
Total	1,29,672	0	0	1,29,672

Further, the comparison for estimated emission reductions as per validated VCS PD and actual observed are detailed below. The emission reductions are lower than the estimated value.

Parameters	tCO ₂ e
Annual Emission Reduction as per registered PDD	32,788
Emission Reductions for the monitoring period as per registered PDD (2191 days)	196,818
Emission reductions achieved in monitoring period	129,672
Percentage of variation when compared with estimated ERs in VCS PD	-34.12 %

APPENDIX X: <TITLE OF APPENDIX>

Use appendices for supporting information. Delete this appendix (title and instructions) where no appendix is required.