



**Verified Carbon  
Standard**

# NEGROS ISLAND SOLAR POWER INC. PROJECT



Document Prepared by EKI Energy Services Limited

<b>Project Title</b>	Negros Island Solar Power Inc. Project
<b>Version</b>	02
<b>Report ID</b>	VVER22701
<b>Date of Issue</b>	28-September-2020
<b>Project ID</b>	1735
<b>Monitoring Period</b>	26-November-2017 to 26-April-2020 (both days included)
<b>Prepared By</b>	EKI Energy Services Limited
<b>Contact</b>	Email ID : prakash@enkingint.org Address: Office no. 201, Plot 48, Scheme 78 part 2 Vijay Nagar, Near Brilliant Convention Centre Indore - 452010 (M.P, India) Website: www.enkingint.org

## CONTENTS

<b>1</b>	<b>PROJECT DETAILS.....</b>	<b>3</b>
1.1	Summary Description of the Implementation Status of the Project .....	3
1.2	Sectoral Scope and Project Type .....	4
1.3	Project Proponent .....	4
1.4	Other Entities Involved in the Project .....	4
1.5	Project Start Date .....	4
1.6	Project Crediting Period .....	4
1.7	Project Location .....	4
1.8	Title and Reference of Methodology .....	6
1.9	Participation under other GHG Programs.....	7
1.10	Other Forms of Credit.....	7
1.11	Sustainable Development.....	7
<b>2</b>	<b>SAFEGUARDS .....</b>	<b>8</b>
2.1	No Net Harm .....	8
2.2	Local Stakeholder Consultation .....	11
2.3	AFOLU-Specific Safeguards .....	12
<b>3</b>	<b>IMPLEMENTATION STATUS .....</b>	<b>12</b>
3.1	Implementation Status of the Project Activity .....	12
3.2	Deviations.....	15
3.3	Grouped Projects .....	15
<b>4</b>	<b>DATA AND PARAMETERS.....</b>	<b>15</b>
4.1	Data and Parameters Available at Validation .....	15
4.2	Data and Parameters Monitored.....	18
4.3	Monitoring Plan.....	19
<b>5</b>	<b>QUANTIFICATION OF GHG EMISSION REDUCTIONS AND REMOVALS .....</b>	<b>22</b>
5.1	Baseline Emissions .....	22
5.2	Project Emissions .....	23
5.3	Leakage.....	23
5.4	Net GHG Emission Reductions and Removals.....	23
	<b>APPENDIX 1: METER DETAILS.....</b>	<b>24</b>
	<b>APPENDIX 2: MAJOR BREAKDOWN DETAILS .....</b>	<b>24</b>

# 1 PROJECT DETAILS

## 1.1 Summary Description of the Implementation Status of the Project

The Negros Island Solar Power Inc. Project (hereafter referred as “the project” involves the installation of 32 MW La Carlota Solar Power Plant which includes two (02) phases of 18 MW and 14 MW, and 48MW Manapla Solar Power Plant. The total installed capacity of the project is 80MW. The Plants are greenfield, stand-alone power plants with a gross peak generation capacity of 32 MWp and 48 MWp DC intended to provide daytime power to the grid throughout the entire year. The design concept is for La Carlota Phase 1, phase 2 and Manapla approximately 70,000 modules, 54,000 modules and 179,000 modules respectively which have been designed to ensure optimum energy efficiency. The project contributes additional peak power to the Visayas grid and assists in stabilizing the power supply in San Carlos City while helping meet the growing energy demand in the region. The average annual exported power generation is expected to be 119,312 MWh. The purpose of the project activity is to generate power using renewable energy source (solar energy) and sell the power generated to the state grid. The project activity is located on Negros Island, within the Cebu-Negros-Panay sub-grid of the Visayas electricity grid.

The Implementation timeline of the project is tabulated below:

Event	32MW La Carlota	48MW Manapla
Date of Construction	03-November-2014	28-May-2015
Commissioning Date	02-March-2016	08-March-2016

Since, the solar power is Green House Gas (GHG) emissions free, the power generated is replacing anthropogenic emissions of greenhouse gases estimated to be approximately 66,039 tCO<sub>2e</sub> per year (annual average), thereon displacing 119,312 MWh/year amount of electricity from the generation-mix of power plants connected to the Philippine electricity grid, which is mainly dominated by thermal/ fossil fuel based power plant. The total estimated emission reductions during the entire crediting period of 10 years will be approximately 660,390 tCO<sub>2e</sub>.

The purpose of the project activity is to generate electricity by the utilization of renewable solar PV technology and further selling the generated energy to the Visayas Grid. In this process there is no consumption of any fossil fuel and hence the project does not lead to any greenhouse gas emissions. Thus, electricity would be generated through sustainable means without causing any negative impact on the environment. In the Pre- project scenario the entire electricity, delivered to the grid by the project activity, would have otherwise been generated by the operation of grid-connected power plants and by the addition of new generation sources (primarily based upon fossil fuels).

The emission reduction of the project during the first monitoring period (26-November-17 and 26-April-20) is 155,337 tCO<sub>2</sub>e.

## 1.2 Sectoral Scope and Project Type

The project activity falls under the following Sectoral scope and Project Type:

Sectoral Scope : 01 - Energy industries (renewable / non-renewable sources)

Project Type : I - Renewable Energy Projects

Methodology : Grid-connected electricity generation from renewable sources --- Version 17.0

## 1.3 Project Proponent

<b>Organization name</b>	Negros Island Solar Power Inc.
<b>Contact person</b>	Lord Lee Van Burgos
<b>Title</b>	Assistant Vice President – Solar Operations
<b>Address</b>	Emerald Arcade, F.C. Ledesma St. San Carlos City, Negros Occidental, Philippines
<b>Telephone</b>	+632 8311235
<b>Email</b>	burgos.llvp@acenergy-devco.com

## 1.4 Other Entities Involved in the Project

Not applicable.

## 1.5 Project Start Date

The project start date is 02-March-2016 on which the first solar PV plant, i.e. 32 MW La Carlota Solar Power Plant was commissioned.

## 1.6 Project Crediting Period

Crediting period start date: 02-March-2016

Crediting period end date: 01-March-2026

The project activity adopts renewable crediting period of 10 years period which can be renewed for maximum 02 times.

## 1.7 Project Location

**La Carlota 32MW Solar Power Plant**

The City of La Carlota is located at the Southwest part of Central Negros Occidental, bounded on the north by the City of Bago, on the east by the mountain ranges of Kanlaon Volcano, on the southwest by the town of La Castellana, on the south by the town of Pontevedra and on the west by the town of San Enrique. The study area is focused on the eight major catchment of La Carlota City. It lies on geographical coordinates between 122° 56' 5" and 122° 56' 25" East Longitude and 10° 25' 10" and 10° 25' 40" North Latitude.

### Manapla 48MW Solar Power Plant

The Municipality of Manapla is situated at 10°57'00" latitude and 123°07'30" longitude. It is approximately 44.7 kilometers away from the city of Bacolod and it is located at the northern part of the province. It is bounded by Cadiz City on the east, by Victorias on the south and Guimaras Strait on the Western and northern portion. The plant is located on Latitude: 10.9° North Latitude and 123.2° East Longitude.

The project location has been highlighted in the map shown below.

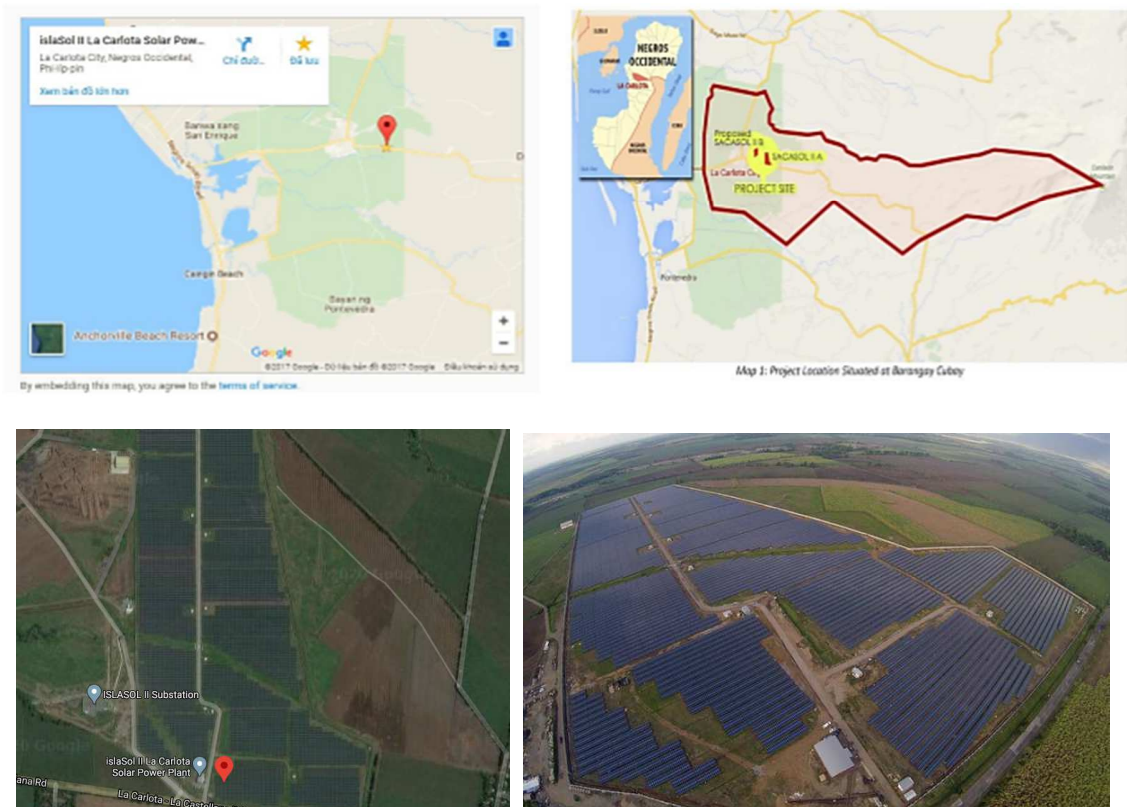

Figure 1. Location of La Carlota 32MW Solar Power Plant.

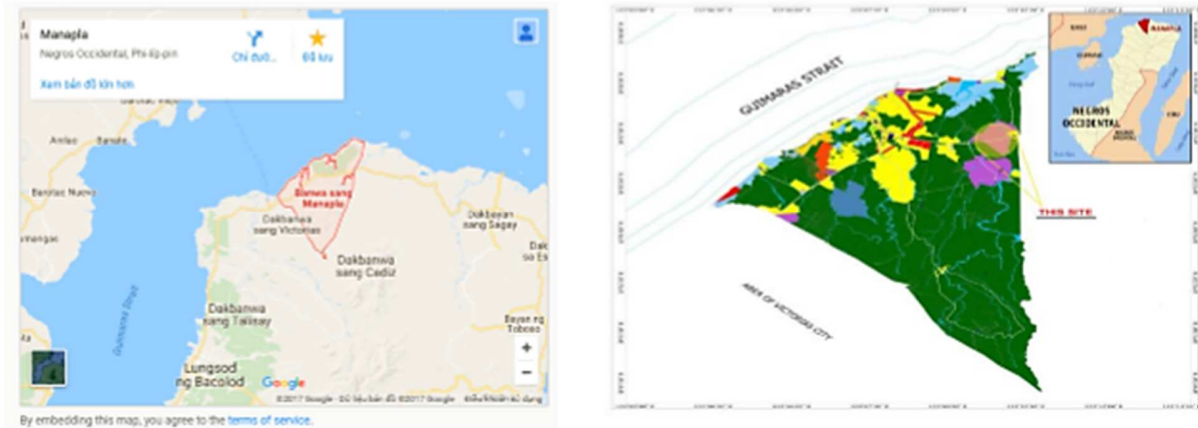

Figure 2. Location of Manapla 48MW Solar Power Plant

## 1.8 Title and Reference of Methodology

Baseline and monitoring methodology:

Approved consolidated baseline methodology ACM0002 (Version 17.0.0)<sup>1</sup>: “Grid-connected electricity generation from renewable sources”.

The methodology draws upon:

- Tool for the Demonstration and Assessment of Additionality<sup>2</sup> (Version 07.0.0)
- Tool to calculate the emission factor for an electricity system<sup>3</sup> (version 06.0)

<sup>1</sup> <https://cdm.unfccc.int/UserManagement/FileStorage/D5YFS9I3VKBT18MQNGX0LPZ6U7AWCO>

<sup>2</sup> <https://cdm.unfccc.int/methodologies/PAMethodologies/tools/am-tool-01-v7.0.0.pdf>

<sup>3</sup> <https://cdm.unfccc.int/methodologies/PAMethodologies/tools/am-tool-07-v6.pdf>

## 1.9 Participation under other GHG Programs

The proposed project activity has not been registered and is not seeking registration at moment under any other GHG programs.

This project activity is not participating in any other GHG program.

## 1.10 Other Forms of Credit

The Project has no intend to generate any other form of GHG-related environmental credit for GHG emission reductions or removals other than VCS. It is going to be registered under VCS program and there will not be any double accounting throughout the project lifetime.

## 1.11 Sustainable Development

As a renewable energy project, it will actively bring about both environmental and economic benefits to the local society and contribute to the local sustainable development. The proposed project activity's contributions to sustainable development are:

- Reducing the dependence on exhaustible fossil fuels for power generation;
- Providing clean electricity to a nation in need of power;
- Reducing air pollution by replacing coal and other fossil fuel fired power plants with clean, renewable power;
- Paving the way for further usage of the country's renewable natural resources by importing technology and creating local capacity;
- Contributing to local economic development through employment creation directly or indirectly.
- Providing additional local income through the taxes that the project proponent will pay to the Local Government Units (LGU). This additional income can be used by the LGU to fund more locally beneficial projects.
- The installation of the renewable energy projects also led to development of basic infrastructure like roads, communication with the nearby cities etc. which also improved in living standards of the local population.

The project has definitely had positive influences on sustainable development in the region and in Philippines. The Negros Island Solar Power Inc. Project has enabled the use of local resources for energy production and thus decrease dependency on imported fossil fuels as an energy source. In addition, the project has a significant effect on air quality in the region; directly and indirectly, create new jobs for local inhabitants during the construction and operation phases.

## 2 SAFEGUARDS

### 2.1 No Net Harm

The IEE studies for the does not identify any significant environmental impacts from the proposed project activity.

The identified impacts are the following:

Issues	Assessment of Impact	Mitigation Measures
Construction Phase		
Land	Vegetation disturbance /Secondary growth sugarcane plant & grasses	<ol style="list-style-type: none"> <li>1. Design and implement an appropriate landscape for greening area.</li> <li>2. Designate location for equipment, and areas of the site which should be kept free of traffic, equipment, and storage.</li> </ol>
	Increased storm water, runoff and soil erosion	<ol style="list-style-type: none"> <li>1. Improve existing side drainage channel to absorb surface runoff.</li> <li>2. Storm water management that minimizes impervious area infiltration by use of recharge areas and use of detention and/or retention basin with outlet control structure.</li> <li>3. Ensure that construction vehicles are restricted to use existing graded roads.</li> <li>4. Site excavation works to be planned such that a section is completed and rehabilitated before another section begins.</li> <li>5. Interconnected open drains will be provided on site.</li> </ol>
	Soil and Water pollution	<p>Use of an integrated solid waste management system i.e. through a hierarchy of options:</p> <ul style="list-style-type: none"> <li>• Waste reduction</li> <li>• Reuse and Recycle</li> <li>• Waste processing</li> <li>• Waste disposal (Disposal to LGU landfill)</li> <li>• Provide facilities for proper handling and storage of construction materials to reduce the amount of wastes.</li> <li>• Use of durable, long-lasting materials that will not need to be replaced as often, thereby reducing the amount of construction wastes generated over time.</li> <li>• Provide proper storage for scrap materials.</li> </ul>

		<ul style="list-style-type: none"> <li>• Use building materials that have minimal or no packaging to avoid the generation of excessive packaging wastes.</li> <li>• Reuse packaging materials such as cartons, cement bags, empty metal and plastic containers to reduce wastes at site.</li> <li>• Dispose waste more responsibly by contracting a registered waste handler who will dispose the wastes at designated sites or landfills only.</li> <li>• Placement of collection bins for segregated wastes to be provided at designated points on site.</li> </ul>
Air	Degradation of ambient air quality	<ul style="list-style-type: none"> <li>▪ Sprinkle water on graded access routes when necessary to reduce dust generation by construction vehicles;</li> <li>▪ Wash truck tires to remove dirt and mud before leaving the site;</li> <li>▪ Ensure strict enforcement of onsite speed limit regulations;</li> <li>▪ Provision of traffic signages at the ingress and outgress of the project site;</li> <li>▪ Personal Protective equipment to be provided to employees and worn.</li> <li>▪ Vehicle idling time shall be minimized;</li> <li>▪ Monitor and brief truck drivers to avoid unnecessary revving engines of stationary vehicles and to switch off engines whenever possible;</li> <li>▪ Vehicles delivering construction materials to site should be adequately maintained to reduce exhaust emissions.</li> <li>▪ Only trucks with engines maintained will be permitted to deliver fuel supplies to reduce emissions</li> </ul>
	Disturbance to residents	<ul style="list-style-type: none"> <li>▪ Sensitize construction vehicle drivers and machinery operators to switch off engines of vehicles or machinery not being used.</li> <li>▪ Sensitize construction drivers to avoid revving of vehicle engines or hooting</li> <li>▪ Ensure that construction machinery are kept in good condition to reduce noise;</li> <li>▪ Ensure that all generators and heavy duty equipment are insulated or placed in enclosures (containers) to minimize ambient noise levels.</li> </ul>

		<ul style="list-style-type: none"> <li>▪ The noisy construction works will entirely be planned to be during daytime when most of the neighbors are awake.</li> </ul>
Water	Increase water demand	<ul style="list-style-type: none"> <li>• Promptly detect and repair of water pipe and tank leaks.</li> <li>• Briefing to construction workers to conserve water by avoiding unnecessary use of water;</li> <li>• Ensure taps are not running when not in use</li> </ul>
	Generation of sewage	<ul style="list-style-type: none"> <li>• Provision of septic tank</li> <li>• Monitor effluent quality regularly to ensure that the stipulated discharge rules and standards are not violated</li> </ul>
	Oil spills	<ul style="list-style-type: none"> <li>• Install oil trapping equipment in areas when there a likelihood of oil spillage such during the maintenance of construction equipment. Soil in such an area will be well protected from contamination.</li> </ul>
People	Accidents and fatalities	<ul style="list-style-type: none"> <li>• Ensure compliance with the Occupational Safety and Health Act (OSHA) provisions e.g. employees to be provided with appropriate PPE</li> </ul>
<b>Operation Phase</b>		
Land	Soil and water pollution	<ul style="list-style-type: none"> <li>• Prepare solid waste management plan</li> <li>• Use of an integrated solid waste management system i.e. through a hierarchy of options:               <ol style="list-style-type: none"> <li>1. Source reduction</li> <li>2. Recycling</li> <li>3. Composting and</li> <li>4. Resource recovery</li> <li>5. Disposal to LGU land fill.</li> </ol> </li> <li>• Ensure that wastes generated at the plant are efficiently managed through recycling, reusing and proper disposal procedures.</li> </ul>
	Surface and ground water contamination from sewage	<ul style="list-style-type: none"> <li>• Provide adequate and safe means of handling sewage generated at the plant (provision of 3-chamber septic tank)</li> <li>• Ensure regular monitoring of the sewage discharged from the project to ensure that the stipulated sewage/effluent discharge rules and standards are not violated</li> </ul>
	Power resource competition	<ul style="list-style-type: none"> <li>• Switch off electrical equipment, appliances and lights when not being used</li> <li>• Install occupation sensing lighting at various consultant locations such as storage areas which are not in use all the time</li> </ul>

		<ul style="list-style-type: none"> <li>• Install energy saving fixtures within the plant.</li> <li>• Monitor energy use during the operation of the project and set targets for efficient energy use</li> <li>• Brief and train workers to use energy efficiently.</li> <li>• Utilization of solar power for project operation</li> </ul>
	Water resource competition	<ul style="list-style-type: none"> <li>• Enforcement of water conservation policy within the plant</li> <li>• Regular check up for water leakage</li> <li>• Install water conserving taps that turn-off automatically when water is not being used</li> </ul>
Air	Dust emissions	<ul style="list-style-type: none"> <li>• Suitable wet suppression techniques need to be utilized in all exposed areas</li> <li>• Enforce low speed limits for vehicles moving within the site</li> </ul>
People	Increased health and safety impacts (accidents and fatalities)	<ul style="list-style-type: none"> <li>• Implement all necessary measures to ensure health and safety of the plant workers and the general public during operation of the power plant as stipulated in the Occupational Safety and Health Act (DOLE)</li> <li>• Ensure compliance with the Occupational Safety and Health Act (OSHA) provisions e.g. employees to be provided with appropriate PPE</li> </ul>

The above assessments indicate that the project is not expected to cause any significant long-term adverse effects to the environment.

## 2.2 Local Stakeholder Consultation

As a part of continual improvement process, feedback from the associated stakeholders is vital, therefore a dedicated Visitor register cum grievance register has been placed at the project site which is accessible to stakeholders to provide their feedback on the project. It is appropriate publicly accessible location at which local stakeholders can provide their feedback on the project. This location is also conducive to continuous and regular checks for stakeholder comments. For the global stakeholders, the suggestion and the grievance can be submitted to [burgos.llvp@acenergy-devco.com](mailto:burgos.llvp@acenergy-devco.com)

Stakeholder meetings were organized at the time of registration of project activity in order to identify the major challenges around the area, stakeholders were invited well in advance through printed invitation, calls, meeting and a notice is placed around the local common areas. Various CSR activities around site are carried out. The local stakeholder are also request to share their experiences and grievances on continuous basis. Registers is used to records the grievances and feedback.

During the current monitoring period, positive feedback are received regarding site operation. No any grievances received during the current monitoring period, therefore, no any mitigation measures are required. In case of grievances, the nature of probable resolution is discussed with the plant head office and implemented by the site incharge. The grievance copies have been submitted to DOE.

### 2.3 AFOLU-Specific Safeguards

This Section is not applicable here as the project activity is not an AFOLU project activity.

## 3 IMPLEMENTATION STATUS

### 3.1 Implementation Status of the Project Activity

The proposed project activity involves the installation of Solar Power Plants in different cities of Negros Occidental, Philippines i.e. La Carlota and Manapla. The total installed capacity of the project is 80 MW.

The project activity is a new facility (Greenfield) and the electricity generated by the Project will be exported to the Visayas electricity grid. The Project therefore displaces an equivalent amount of electricity which would have otherwise been generated by fossil fuel dominant electricity grid. The Project Proponents plan to avail the VCS benefits for the Project.

In the Pre- project scenario the entire electricity, delivered to the grid by the project activity, would have otherwise been generated by the operation of grid-connected power plants which is mainly dominated by fossil fuels or by the addition of new generation sources.

The project shall result in replacing anthropogenic emissions of greenhouse gases (GHG's) estimated to be approximately 66,039 tCO<sub>2e</sub> per year, thereon displacing 119,312 MWh/year amount of electricity from the grid.

#### **Solar power technology**

The main components of the solar farm include the photovoltaic (PV) modules, solar cable connectors, current and voltage controller, and inverter. The modules are equipped with efficient, polycrystalline cells and have a high nominal output of 240 W-260 W at the nominal operating temperature of 43°C +/- 2°. At the rear of each module is a connection box with the connection cables, plug, and socket. The solar modules will be mounted securely using a mounting system that does not require cutting to size or drilling and has a high corrosion resistance. The inverter converts the direct current (DC) to the utilizable alternative current (AC). It is accompanied by a spacious ventilation system with temperature-controlled fans. The operation conditions of the inverter are -25°C ... +62°C. Cables also connect the inverter directly to the grid.

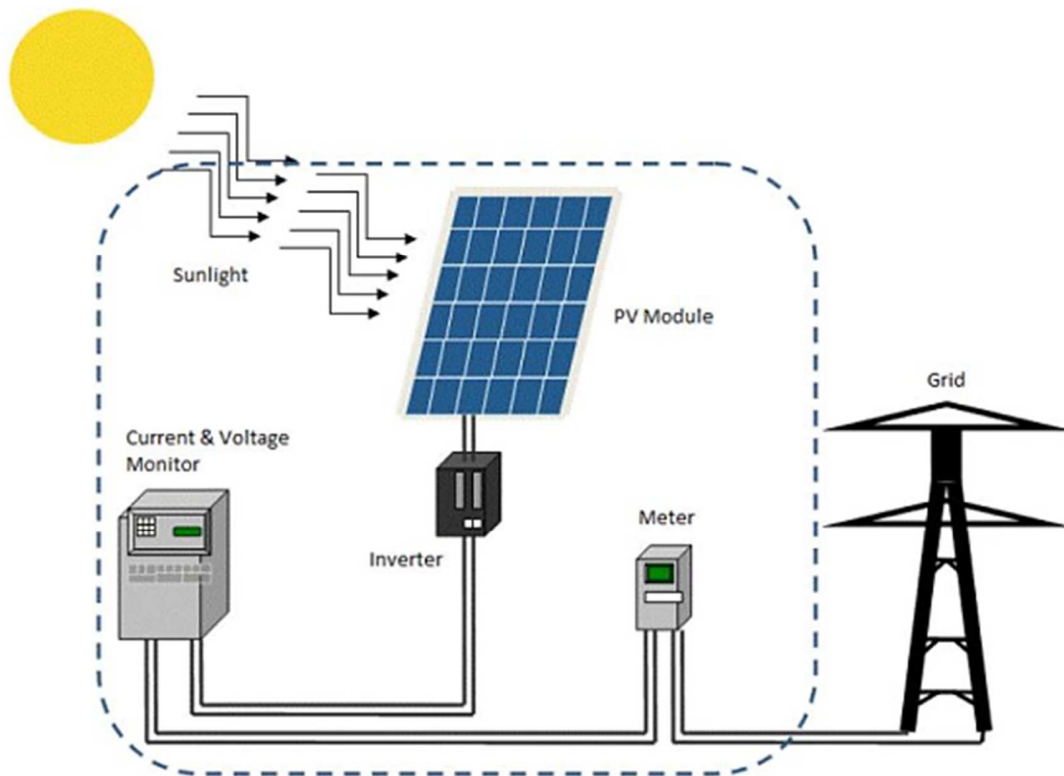

The project activity is harnessing solar energy through installation of PV with total installed capacity of 80 MW. Solar energy is a pollution-free, infinitely sustainable form of energy. It does not use fossil fuel. It does not produce greenhouse gases, and it does not produce toxic or radioactive waste. Therefore the technology used for the project activity is environmentally safe and sound.

The project activity is generating power using solar energy, which is a renewable source of energy. The solar PV system mainly consists of PV modules, module mounting structures, junction boxes, Inverters, regulators, monitoring devices etc. The solar PV cells convert solar radiation into DC current. The solar panels are installed in arrays. The modules in the each array are connected in parallel and/or series in order to get the preferred current & voltage which match with the rated input parameters of the inverter. The Inverter connected in each array converts the DC current to AC current. The electricity collected from all the inverters in La and Manapla is stepped up to 13.8 kV through individual inverter stations 13.8kV/405V transformers. The 13.8 kV electricity from the individual inverter stations are stepped up to 69kV through 69kV/13.8 kV transformer of the plant and exported through a transmission line that leads to the substation owned by the National Grid Corp. of the Philippines. The Grid Operator (NGCP) further steps this up from 69 kV to 138 kV and is then supplied to Visayas grid. The operational life time of the project activity is 25 years. The commissioning of the project activity has been completed and details are mentioned in section 1.1.

There has been no major downtime of equipment's, overhaul times or exchange of equipment's in the project activity during the current monitoring period. The project underwent scheduled

breakdown and maintenance during the monitoring period. The project is in continuous operation since commissioning.

**Total emission reductions achieved in this monitoring period:**

During the Current Monitoring Period from 26-November-2017 to 26-April-2020 (First and last date included) the project activity has contributed 155,337 tCO<sub>2e</sub> GHG reductions.

Technical specification of solar PV module and other components installed in the project are tabulated below:

Category	La Carlota (32 MW)		Manapla (48 MW)	
<b>PV Modules</b>				
Module Model	Conergy PH 260P	Conergy PE 265P	Conergy PE 275M	Conergy PE 270M
Module type	Framed	Framed	Framed	Framed
Nominal output	260W	265W	275W	270W
Unit Nom. Power	260 Wp	265 Wp	275 Wp	270 Wp
Number of PV modules	123,096 (Phase 1 18MW: 69,240 modules Phase 2 14MW: 53,856 modules)	92,352	34,632	52,056
Total nominal Power Output	Phase 1: 18,002 kWp Phase 2: 14,003 kWp	24,473 kWp	9,524 kWp	14,055 kWp
No. of cells	60	60	60	60
Cell dimensions	156x156mm	156x156mm	156x156mm	156x156mm
Cell type	Polycrystalline cell, 3-busbar technology	Polycrystalline, 3-busbar technology	Monocrystalline, 3-busbar technology	Monocrystalline, 3-busbar technology
Module weight	19.5kg	18.2kg	18.2kg	18.2kg
Maximum permissible load	5,400Pa	5,400Pa	5,400Pa	5,400Pa
Maximum permissible System voltage	1,000V	1,000V	1,000V	1,000V
<b>Inverter</b>				
Inverter model	Sunny Central 850CP XT	Sunny Central 900CP XT		
Operating voltage	568-850V	596-850V		
Unit Nom. Power	850 kWac	900 kWac		

No. of inverter	32 units (Phase 1 18MW: 18 units Phase 2 14MW: 14 units)	23 units	9 units	13 units
Total Power	Phase 1: 15,300 kWac Phase 2: 11,900 kWac	20,700 kWac	8,100 kWac	11,700 kWac
<b>Transformer</b>				
Serial No.	VN01106 3- phase transformer	75660		
No. of transformer	01 set	01 set		
Highest rate power	35/35 MVA	50 MVA		
Voltage	69 ± 8 x 1.25%/13.8 kV	69 ± 8 x 1.25% Steps		
Frequency	60Hz	60 Hz		

## 3.2 Deviations

### 2.1.1 Methodology Deviations

There is no request for deviation applied during this monitoring period

### 2.1.2 Project Description Deviations

No project deviations observed during this course of monitoring period.

## 3.3 Grouped Projects

This project activity is not a grouped project activity.

# 4 DATA AND PARAMETERS

## 4.1 Data and Parameters Available at Validation

**Data / Parameter**

EF<sub>grid,OM,y</sub>

<b>Data unit</b>	tCO <sub>2</sub> /MWh
<b>Description</b>	Operating margin CO <sub>2</sub> emission factor for grid connected power generation in year y calculated using the latest version of “Tool to calculate the emission factor for an electricity system”.
<b>Source of data</b>	Data provided by DOE Philippines
<b>Value applied</b>	0.6032
<b>Justification of choice of data or description of measurement methods and procedures applied</b>	As per the “Tool to calculate the emission factor for an electricity system”, version 06.0.0
<b>Purpose of Data</b>	Calculation of baseline emissions
<b>Comments</b>	Value is fixed and ex-ante for the entire crediting period

<b>Data / Parameter</b>	EF <sub>grid,BM,y</sub>
<b>Data unit</b>	tCO <sub>2</sub> /MWh
<b>Description</b>	Build margin CO <sub>2</sub> emission factor for grid connected power generation in year y calculated using the latest version of “Tool to calculate the emission factor for an electricity system”
<b>Source of data</b>	Data provided by DOE Philippines
<b>Value applied</b>	0.4044
<b>Justification of choice of data or description of measurement methods and procedures applied</b>	As per the “Tool to calculate the emission factor for an electricity system”, version 06.0.0
<b>Purpose of Data</b>	Calculation of baseline emissions
<b>Comments</b>	Value is fixed and ex-ante for the entire crediting period

<b>Data / Parameter</b>	EF <sub>grid,CM,y</sub>
<b>Data unit</b>	tCO <sub>2</sub> /MWh
<b>Description</b>	Combined margin CO <sub>2</sub> emission factor for grid connected power generation in year y calculated using the latest version of “Tool to calculate the emission factor for an electricity system”.
<b>Source of data</b>	Data provided by DOE Philippines
<b>Value applied</b>	0.5535
<b>Justification of choice of data or description of</b>	As per the “Tool to calculate the emission factor for an electricity system”, version 06.0.0.

<b>measurement methods and procedures applied</b>	
<b>Purpose of Data</b>	Calculation of baseline emissions
<b>Comments</b>	Value is fixed and ex-ante for the entire crediting period

<b>Data / Parameter</b>	$EG_{m,y}$
<b>Data unit</b>	MWh
<b>Description</b>	Net electricity generated by power plant/unit m, in year y
<b>Source of data</b>	Data provided by DOE Philippines
<b>Value applied</b>	For detailed values; see the GEF spreadsheet calculation
<b>Justification of choice of data or description of measurement methods and procedures applied</b>	-
<b>Purpose of Data</b>	Calculation of baseline emissions
<b>Comments</b>	Value is fixed and ex-ante for the entire crediting period

<b>Data / Parameter</b>	$EF_{CO_2,m,i,y}$
<b>Data unit</b>	tCO <sub>2</sub> /GJ
<b>Description</b>	CO <sub>2</sub> emission factor of fuel type I used in power unit m in year y
<b>Source of data</b>	Data provided by DOE Philippines
<b>Value applied</b>	For detailed values; see the GEF spreadsheet calculation
<b>Justification of choice of data or description of measurement methods and procedures applied</b>	-
<b>Purpose of Data</b>	Calculation of baseline emissions
<b>Comments</b>	Value is fixed and ex-ante for the entire crediting period

<b>Data / Parameter</b>	$\eta_{m,y}$
<b>Data unit</b>	-
<b>Description</b>	Average net energy conversion efficiency of power unit m in year y.
<b>Source of data</b>	Data provided by DOE Philippines
<b>Value applied</b>	For detailed values; see the GEF spreadsheet calculation

Justification of choice of data or description of measurement methods and procedures applied	-
Purpose of Data	Calculation of baseline emissions
Comments	Value is fixed and ex-ante for the entire crediting period

## 4.2 Data and Parameters Monitored

Data / Parameter	$EG_{\text{facility},y}$
Data unit	MWh/yr
Description	Quantity of net electricity generation supplied by the project plant/unit to the grid in year y
Source of data	Electricity meter(s)
Description of measurement methods and procedures to be applied	<p>This parameter should be either monitored using bi-directional energy meter or calculated as difference between:</p> <ul style="list-style-type: none"> <li>(i) the quantity of electricity supplied by the project/unit to the grid (<math>EG_{\text{export},y}</math>); and</li> <li>(ii) The quantity of electricity delivered to the project plant/unit from the grid (<math>EG_{\text{import},y}</math>).</li> </ul> <p>The net supply of power to the grid by the proposed project is calculated based on measured parameters <math>EG_{\text{export},y}</math> and <math>EG_{\text{import},y}</math>. These two parameters, import and export to the grid, are measured at the same location near the connection to the grid, through standard electricity metering instrument(s) <math>M_x</math>. The metering instruments will be installed at the grid-connected point to measure the amount of electricity going from and to the grid. The readings of electricity will be continuously measured by metering instrument itself and monthly recorded. The accuracy of the meter(s) will meet the requirements of national standards and regulations shall be of IEC 687 class 0.2.</p> <p>Please refer to Appendix I for more details. Person/entity responsible for the measurements: the project participant (i.e. NISP)</p>
Frequency of monitoring/recording	Continuous measurement and at least monthly recording
Value monitored	280,655 MWh
Monitoring equipment	The two parameters, import and export to the grid, are measured at the same location near the connection to the grid, through standard electricity metering instrument(s) $M_x$ . The metering

	instruments will be installed at the grid-connected point to measure the amount of electricity going from and to the grid. The readings of electricity will be continuously measured by metering instrument itself and monthly recorded. The accuracy of the meter(s) will meet the requirements of national standards and regulations shall be of IEC 687 class 0.2. Please refer to Appendix I for more details. Person/entity responsible for the measurements: the project participant (i.e. NISP)
QA/QC procedures to be applied	This data will be directly used for calculation of emission reductions. Measurement results of electricity supplied to the grid and that delivered from the grid to the project will be crosschecked with records for sold electricity. The meter(s) will be calibrated annually in accordance with national standards and procedures.
Purpose of the data	Calculation of baseline emissions
Calculation method	$EG_{\text{facility},y} = EG_{\text{export},y} - EG_{\text{import},y}$
Comments	NA

### 4.3 Monitoring Plan

The monitoring plan, which is implemented by the PP describes about the monitoring organization, parameters to be monitored, monitoring practices, quality assurance, quality control procedures, data storage and archiving.

The authority and responsibility for registration, monitoring, measurement, reporting and reviewing of the data results with the PP. PP proposed the following structure for data monitoring, collection, data archiving and calibration of equipment for this project activity instances. The team comprises of the following members:

#### Organisational Structure for Monitoring

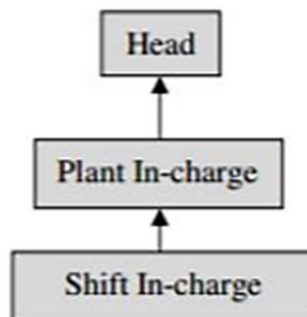

PP has assigned the responsibility of operation and maintenance of project activity instances with relevant and authorized O&M contractors. The Plant In-charge and Shift In-Charge would be deployed by O&M contractors.

**Responsibilities of Head:** Overall functioning and maintenance of the data.

**Responsibilities of Plant In-charge:** Responsibility for Maintains the data records, ensures completeness of data, and reliability of data (calibration of equipment).

**Responsibilities of Shift In-charge:** Responsibility for day to day data collection and maintains day to day log book for monitored data.

In the event when the individual verification period dates and billing cycle dates of the project activity does not coincide, then the electricity export will be apportioned based on number of days. The ratio of number of days under monitoring period and total number of days under billing cycle will multiplied to total electricity export to billing cycle.

For project activity which involves solar projects with common metering, apportioning will be followed to determine net electricity export to grid. The apportioning procedure is not under control of PP, thus value of net electricity supplied to grid is available to PP and same is mentioned as monitoring parameter. The value of net electricity supplied to grid is used for ER calculations.

It is to be noted that the metering arrangement, accuracy class of meters, feeder arrangements, calibration frequency of meters are under control of state electricity board and PP do not have any control on it. Thus any deviation at actual site or during verification is accepted, however no any deviation activity occurred during the current monitoring period.

#### **QA & QC Procedures to be followed**

Necessary check meters as required would be installed, to operate in standby mode or when the main meters are not working. All meters will be calibrated annually. Records of calibration certificates will be maintained for verification. Hence, high quality is ensured with the above parameters. The calibration of meters is under purview of state electricity board and CME/ project activity instances owner do not have any control on it.

#### **Data Recording and Storage**

For measuring the net energy supplied to grid by the project activity at the interconnection point, one set of Main meter and Check Meter shall be provided. Representatives of both project activity Owner and Philippine Electricity Market Corporation (PEMC) will be present to record the monthly meter readings. The PEMC will prepare the monthly record for the net energy supplied to the grid and same will be used as a basic document for monitoring and verification of the net energy supplied to the grid. Based on the monthly record, the project activity Owner shall raise an invoice to the PEMC for payment.

The above documents will be kept at safe storage for verification of emission reductions generated from the project activity. The period of data storage will be 2 years beyond crediting period.

**Emergency preparedness**

The project activity will not result in any unidentified activity that can result in substantial emissions from the project activity. However, in case monitoring equipment get failed or found faulty, they shall be replaced with calibrated meters as quickly as possible. In case main meter get failed or found faulty, the reading of check meter will be considered.

The schematic diagram for the plants are as follows:

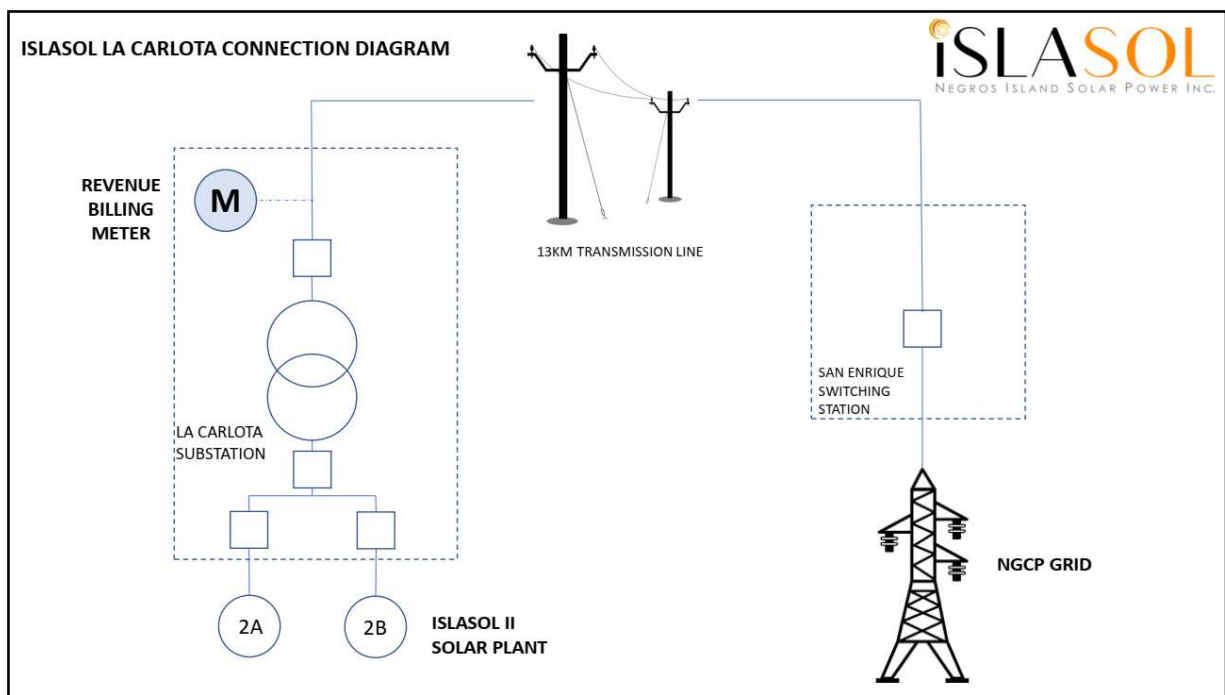

Figure 3. ISLASOL LA CARLOTA Connection Diagram

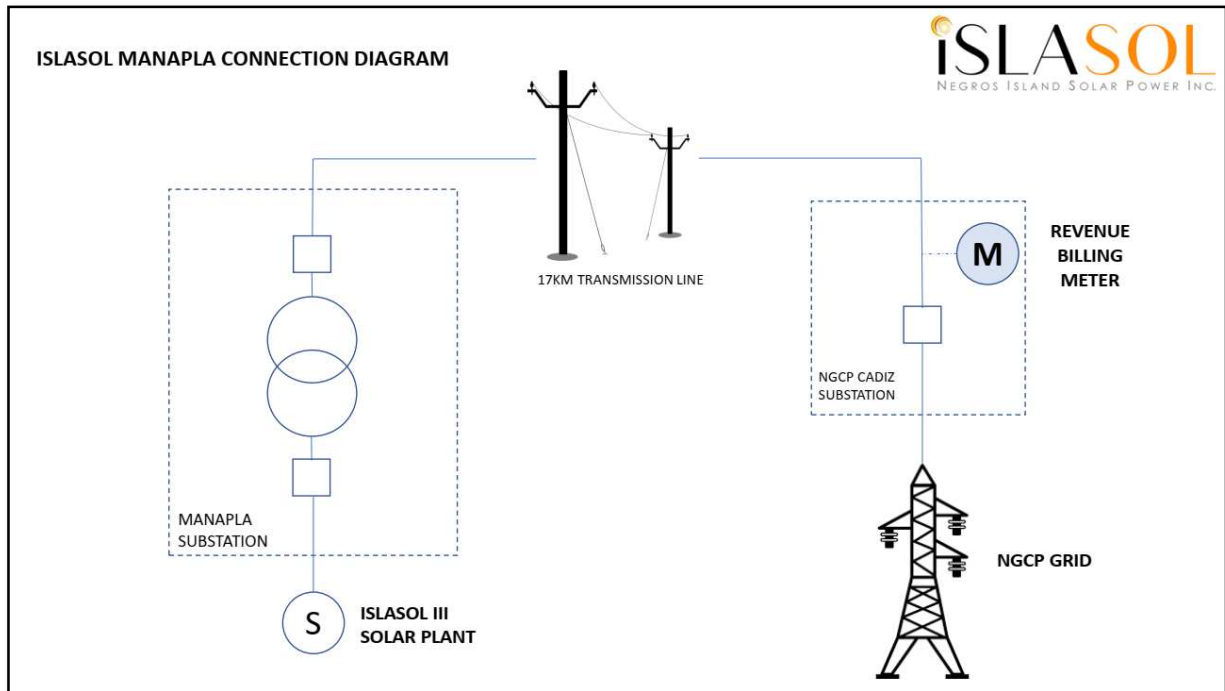

Figure 4. ISLASOL MANAPLA Connection Diagram

## 5 QUANTIFICATION OF GHG EMISSION REDUCTIONS AND REMOVALS

### 5.1 Baseline Emissions

$$BE_y = EG_{\text{facility},y} \times EF_{\text{grid},\text{CM},y}$$

Where:

$BE_y$ : Baseline emissions in year  $y$  (tCO<sub>2e</sub>/yr)

$EG_{\text{facility},y}$ : Quantity of net electricity generation that is produced and fed into the grid as a result of the implementation of the VCS project activity in year  $y$  (MWh/yr)

$EF_{\text{grid},\text{CM},y}$ : Combined margin CO<sub>2</sub> emission factor for grid connected power generation in year  $y$  calculated using the “Tool to calculate the emission factor for an electricity system” version 06 (tCO<sub>2e</sub>/MWh).

Then  $BE_y = 280,655 \times 0.5535 = 155,337$  tCO<sub>2e</sub> (rounded down)

La Carlota Site: The delay in calibration observed in the month of February 2019.

Manapla Site: The delay in calibration observed in the month of February 2019 and February 2020, therefore error factor have been applied for the same month.

## 5.2 Project Emissions

As per methodology, for renewable energy projects, there is no any project emissions occurred. Hence,  $PE_y = 0$ .

## 5.3 Leakage

As per methodology, for renewable energy projects, there is no any leakage emissions occurred. Hence,  $LE_y = 0$ .

## 5.4 Net GHG Emission Reductions and Removals

Year	Baseline emissions or removals (tCO <sub>2</sub> e)	Project emissions or removals (tCO <sub>2</sub> e)	Leakage emissions (tCO <sub>2</sub> e)	Net GHG emission reductions or removals (tCO <sub>2</sub> e)
26-November-2017 to 31-December-2017	5,391	0	0	5,391
01-January-2018 to 31-December-2018	62,773	0	0	62,773
01-January-2019 to 31-December-2019	64,786	0	0	64,786
01-January-2020 to 26-April-2020	22,387	0	0	22,387
<b>Total</b>	<b>155,337</b>	<b>0</b>	<b>0</b>	<b>155,337</b>

The actual emission reduction is lower than 2.66% from the estimated emission reduction due to less number of sunshine hours which is conservative.

## APPENDIX 1: METER DETAILS

Meter and Calibration details for current monitoring period:

### 1. La Carlota 32MW Solar Power Plant

Meter Type	Meter Serial Number	Make	Accuracy Class	Calibration Date
Main Meter	153631320	AMETEK	0.2	11-February-2017 07-February-2018 17-February-2019 09-February-2020
Check Meter	15882036	ELSTER	0.2	11-February-2017 07-February-2018 17-February-2019 09-February-2020

The delay in calibration observed in the month of February 2019, therefore error factor have been applied for the same month. Due date of La Carlota 32 MW Energy meter calibration is 08/02/2021.

### 2. Manapla 48MW Solar Power Plant

Meter Type	Meter Serial Number	Make	Accuracy Class	Calibration Date
Main Meter	153631349 (meter change on 02/06/2018)	AMETEK	0.2	11-February-2017
	153475770	LANDIS & GYR	0.2	06-February-2018 09-February-2019 20-February-2020
Check Meter	15882039 (meter change on 02/06/2018)	ELSTER	0.2	11-February-2017
	15882102	ELSTER	0.2	06-February-2018 09-February-2019 20-February-2020

The delay in calibration observed in the month of February 2019 and February 2020, therefore error factor have been applied for the same month. Due date of Manapla 48 MW Energy meter calibration is 19/02/2021.

## APPENDIX 2: MAJOR BREAKDOWN DETAILS

La Carlota 32MW Site

Date	Breakdown hours	Description
24-July-2018	4.03	curtailment due to scheduled shutdown of Leyte-Luzon HVDC line
21-September-2018	3.49	curtailment due to the limitation of Samboan-Colon line 1, as towers of line 2 were toppled during the landslide in Cebu last Sep 20
22-September-2018	3.04	curtailment due to the limitation of Samboan-Colon line 1, as towers of line 2 were toppled during the landslide in Cebu last Sep 20
23-September-2018	4.47	curtailment due to the limitation of Samboan-Colon line 1, as towers of line 2 were toppled during the landslide in Cebu last Sep 20
26-September-2018	3.14	curtailment due to the limitation of Samboan-Colon line 1, as towers of line 2 were toppled during the landslide in Cebu last Sep 20
30-September-2018	3.98	curtailment due to the limitation of Samboan-Colon line 1, as towers of line 2 were toppled during the landslide in Cebu last Sep 20
03-October-2018	4.37	curtailment due to the limitation of Samboan-Colon line 1, as towers of line 2 were toppled during the landslide in Cebu last Sep 20
04-October-2018	4.05	curtailment due to the limitation of Samboan-Colon line 1, as towers of line 2 were toppled during the landslide in Cebu last Sep 20
05-October-2018	4.75	curtailment due to the limitation of Samboan-Colon line 1, as towers of line 2 were toppled during the landslide in Cebu last Sep 20
06-October-2018	4.83	curtailment due to the limitation of Samboan-Colon line 1, as towers of line 2 were toppled during the landslide in Cebu last Sep 20
10-October-2018	3.29	curtailment due to the limitation of Samboan-Colon line 1, as towers of line 2 were toppled during the landslide in Cebu last Sep 20
12-October-2018	3.08	curtailment due to the limitation of Samboan-Colon line 1, as towers of line 2 were toppled during the landslide in Cebu last Sep 20
24-March-2019	3.10	NGCP conducted scheduled maintenance for Cebu-Negros submarine cable line 1. Plant was curtailed to prevent overloading of line 2
18-July-2019	3.95	plant was curtailed by NGCP to stabilize system frequency as affected by scheduled shutdown of HVDC
03-December-2019	4.22	plant was curtailed by NGCP due to the unavailability of HVDC Visayas-Luzon link

## Manapla 48MW Site

Date	Breakdown hours	Description
24-July-2018	4.88	curtailment due to scheduled shutdown of Leyte-Luzon HVDC line
25-July-2018	3.61	curtailment due to scheduled shutdown of Leyte-Luzon HVDC

		line
21-September-2018	4.38	curtailment due to the limitation of Samboan-Colon line 1, as towers of line 2 were toppled during the landslide in Cebu last Sep 20
23-September-2018	3.22	curtailment due to the limitation of Samboan-Colon line 1, as towers of line 2 were toppled during the landslide in Cebu last Sep 20
25-September-2018	3.85	curtailment due to the limitation of Samboan-Colon line 1, as towers of line 2 were toppled during the landslide in Cebu last Sep 20
26-September-2018	4.77	curtailment due to the limitation of Samboan-Colon line 1, as towers of line 2 were toppled during the landslide in Cebu last Sep 20
27-September-2018	6.03	curtailment due to the limitation of Samboan-Colon line 1, as towers of line 2 were toppled during the landslide in Cebu last Sep 20
28-September-2018	4.17	curtailment due to the limitation of Samboan-Colon line 1, as towers of line 2 were toppled during the landslide in Cebu last Sep 20
29-September-2018	3.70	curtailment due to the limitation of Samboan-Colon line 1, as towers of line 2 were toppled during the landslide in Cebu last Sep 20
03-September-2018	3.08	curtailment due to the limitation of Samboan-Colon line 1, as towers of line 2 were toppled during the landslide in Cebu last Sep 20
04-September-2018	3.90	curtailment due to the limitation of Samboan-Colon line 1, as towers of line 2 were toppled during the landslide in Cebu last Sep 20
05-October-2018	4.76	curtailment due to the limitation of Samboan-Colon line 1, as towers of line 2 were toppled during the landslide in Cebu last Sep 20
06-October-2018	3.80	curtailment due to the limitation of Samboan-Colon line 1, as towers of line 2 were toppled during the landslide in Cebu last Sep 20
09-October-2018	3.57	curtailment due to the limitation of Samboan-Colon line 1, as towers of line 2 were toppled during the landslide in Cebu last Sep 20
09-December-2018	3.24	curtailment due to scheduled shutdown of HVDC, Leyte-Luzon link
12-July-2019	3.68	plant output was curtailed as instructed by NGCP to stabilize the grid during the scheduled shutdown of the HVDC linespare
18-July-2019	4.55	plant was curtailed by NGCP to stabilize system frequency as affected by scheduled shutdown of HVDC

05-December-2019	6.59	curtailment during the tripping of the HVDC due to the typhoon
------------------	------	--