



**Monitoring report form for CDM project activity
(Version 08.0)**

MONITORING REPORT			
Title of the project activity	San Jacinto Tizate geothermal project		
UNFCCC reference number of the project activity	0198		
Version number of the PDD applicable to this monitoring report	4.0		
Version number of this monitoring report	01		
Completion date of this monitoring report	18/04/2021		
Monitoring period number	8 th		
Duration of this monitoring period	01/01/2011 to 31/05/2012		
Monitoring report number for this monitoring period	NA		
Project participants	1. Polaris Energy Nicaragua S.A. 2. Blues Traveler Environmental Limited 3. Ecoscurities, Ltd.		
Host Party	Nicaragua		
Applied methodologies and standardized baselines	Methodology-ACM0002 Version 4.0 "Consolidated baseline and monitoring methodology for grid-connected electricity generation from renewable sources" Standardized Baseline: Not Applicable		
Sectoral scopes	Sectoral Scope Number 1: Energy Industries – Renewable Sources		
Amount of GHG emission reductions or net anthropogenic GHG removals achieved by the project activity in this monitoring period	Amount achieved before 1 January 2013	Amount achieved from 1 January 2013 until 31 December 2020	Amount achieved from 1 January 2021
	0 tCO ₂ e	0 tCO ₂ e	0 tCO ₂ e
Amount of GHG emission reductions or net anthropogenic GHG removals estimated ex ante for this monitoring period in the PDD	397,598 tCO ₂ e		

SECTION A. Description of project activity

A.1. General description of project activity

The Project Activity involves the construction of a Geothermal Power Plant (GPP) in San Jacinto, Nicaragua. The San Jacinto geothermal project is being carried out by Polaris Geothermal Inc. through its Nicaraguan subsidiary, Polaris Energy Nicaragua S.A. (PENSA)¹. They have signed a power purchase agreement (PPA) with Union Fenosa, the electricity utility in Nicaragua, for 20 years².

The proposed development involves the implementation and construction of a 77 MW geothermal plant³.

The development was carried out in the following two phases:

1. Phase 1: Installation of two backpressure steam turbo-generators of 5 MW each to test the production capacity of the geothermal field. Both turbo-generators were commissioned in July 2005, operated until July 2012, and decommissioned in Phase 2 of the project activity, in March 20; and,
2. Phase 2: Installation of two 38.5 MW condensing steam power units consisting of single flash steam/brine separation, with steam directed to a conventional condensing steam turbine. The first power unit began commercial operation in January 2012 and the second in February 2013. The expected lifetime of each of these power units is 40 years.

Total GHG emission reductions during the monitoring period is 0 tCO₂e

A.2. Location of project activity

Host Party- Nicaragua

State- Department of Leon

City- San Jacinto

The Project Activity is to be located in the north-west of Managua, in the Department of León, between the towns of Telica and Malpaisillo, to approximately 120 km from Managua and 20 km from the City of León. Nicaragua is situated in the Central American Isthmus, bordering both the Caribbean Sea and the North Pacific Ocean, between Costa Rica and Honduras. The geographic coordinates are 13 00 N, 85 00 W.

The project site is approximately 2km to the North of Caserío San Jacinto, which is to the north side of the Tizato hill. The project site covers approximately 8km², which is unoccupied except for sparse subsistence farming in some peripheral areas. The area to be occupied for the project has been acquired from the nearby farmers. However, only 25% of the total project site will actually be utilized for equipment and the project developer is happy to permit that the remainder 75% of the land to be used for farming or grazing purposes.

The nearest village is San Jacinto, a small settlement adjacent to the established project base camp. It is isolated from the project site by low hills and no part of the project is visible from the village. Paved road access passes through San Jacinto. A nearby gravel road turns off a short

¹ PENSA was previously called San Jacinto Power S.A.

² As a result of Geothermal Law reform, the duration of the PPA was automatically extended through 30 January 2029. An addendum to the PPA was issued reflecting this extension.

³ Capacity installed according to the nameplate of the turbines.

distance north of the base camp, and provides access to the site. The plants will be installed at an altitude of 200 metres above sea level. The wells will be located between 160 and 180 metres above sea level in the San Jacinto area.



Figure 1. Map of Nicaragua showing project location

A.3. Parties and project participants

Parties involved	Project participants	Indicate if the Party involved wishes to be considered as project participant (Yes/No)
Nicaragua(host Party)	Private entity: Polaris Energy Nicaragua S.A. (previously called San Jacinto Power S.A)	No
United Kingdom of Great Britain and Northern Ireland	Private entity: Blues Traveler Environmental Limited	No
United Kingdom of Great Britain and Northern Ireland	EcoSecurities Ltd.	No
Switzerland	EcoSecurities, Ltd	No

A.4. References to applied methodologies and standardized baselines

Sectoral Scope: 01-Energy industries (renewable / non-renewable sources)

Methodology : ACM0002 “Large-scale Consolidated Methodology - Grid-connected electricity generation from renewable sources” (Version 4.0)

Project Type : I- Renewable energy projects

Tool Used : Tool-07 “Tool to calculate the emission factor for an electricity system” (Version 07.0)⁴

Tool-01 "Tool for the demonstration and assessment of additionality" (Version 02)⁵

Tool-11 “Assessment of the validity of the original/current baseline and update of the baseline at the renewal of the crediting period” (Version 03.0.1)⁶

⁴ <https://cdm.unfccc.int/methodologies/PAmethodologies/tools/am-tool-07-v7.0.pdf>

⁵ https://cdm.unfccc.int/EB/022/eb22_repan8.pdf

All above methodologies and tools can be found at the UNFCCC website⁷

A.5. Crediting period type and duration

Type - Renewable (7 Years)

Duration of Crediting Period - 01/06/2005 to 31/05/2012 (first crediting period)

SECTION B. Implementation of project activity

B.1. Description of implemented project activity

The implementation of the project activity comprises two phases. The second phase is developed in two stages. These are described in Table A.3.1 below.

Table A3.1 Phases of the project activity and technologies to be used

	Phase 1	Phase 2	
		Stage 1 (Fuji Unit 1)	Stage 2 (Fuji Unit 2)
Starting date of commercial operation	01/06/2005	07/01/2012	08/02/2013
Decommission date	08/02/2013	Decommission date is unplanned	Decommission date is unplanned
Installed capacity ⁸	10 MW	38.5 MW	38.5 MW
Plant load factor ⁹	98%	98%	98%
Net capacity factor ¹⁰	92.84%	92.84%	92.84%
Annual gross energy production ¹¹	81,327 MW	313,112 MW	313,112 MW
Annual estimated electricity production ¹²	78,888 MWh	284,932 MWh	284,932 MWh
Production period	From 01/06/2005 to July 2012	From 07/01/2012 to the decommission date	From 08/02/2013 to the decommission date
Number of turbines	2 x 5 MW	1 x 38.5 MW	1 x 38.5 MW
Technology	Back pressure turbines	Condensing turbine (manufacturer Fuji)	Condensing turbine (manufacturer Fuji)

Table A3.2 Project activity at the end of the first crediting period

	As of 31/05/2012
--	-------------------------

⁶ <https://cdm.unfccc.int/methodologies/PAMethodologies/tools/am-tool-11-v3.0.1.pdf>

⁷ <http://cdm.unfccc.int/methodologies/PAMethodologies/approved.html>

⁸ Installed capacity as per turbines nameplates.

⁹ Presented in third party engineering report "Value Added Report" dated 20 November 2009, by Sinclair Knight Merz (SKM). Page 19.

¹⁰ Presented in third party engineering report "Value Added Report" dated 20 November 2009, by Sinclair Knight Merz (SKM). Page 19.

¹¹ As calculated in Table B.3.2

¹² As calculated in Table B.3.2

Installed capacity ¹³	48.5 MW
Plant load factor ¹⁴	98%
Net capacity factor ¹⁵	92.84%
Annual gross energy production ¹⁶	159,299.8 MWh
Annual estimated electricity production	146,996 MWh

Phase 1 of the Project

In Phase 1, the project developer installed two 5 MW backpressure steam turbo-generators and the associated equipment, which were commissioned in June 2005. These two 5 MW backpressure turbine generator units produced electricity up to the first quarter of 2012. They remained offline when the Fuji units of Phase 2 entered into commercial operation. The facilities of the backpressure units were subsequently decommissioned in phase 2 (March 2013). Figure 1 below shows a schematic diagram of Phase 1.

Phase 2 of the Project

In Phase 2, the project developer installed two 38.5 MW Fuji single flash condensing turbine and generator units adjacent to the Phase 1 units. The first 38.5 MW Fuji turbine was commissioned in January 2012. The second was commissioned in February 2013. After the first Fuji turbine was installed, the backpressure units were only operated intermittently, until they were taken offline in July 2012. They were subsequently decommissioned on 5 March 2013, when the second Fuji turbine was commissioned.

The selected technology is the development of a geothermal flash steam plant that uses geothermal fluids above 182°C. The high temperature pressurized fluid is passed through a separator which allows a portion of the flow to “flash” off as steam, which is directed to a turbine to generate electricity. Then the electricity produced is supplied to the grid through a 12.9 km transmission line.

The turbines for Phase 2 were fabricated in 2009 by Fuji Electric Company of Japan, which are of geothermal use, characterized by having a very efficient steam rate. In addition, each power unit will require a condenser, which is designed for the San Jacinto environmental conditions.

For Phase 2, A combination of workovers or and re-drills of existing wells and the drilling of new wells will provide the necessary additional production fluid requirement. Also, the electrical transmission system installed for the Phase 1 development was modified by the installation of a second circuit and expansion of the switchyard at the PENSA power substation. In addition, the production wells, injection wells and steam-field system servicing the backpressure units were connected to the steam-field system to supply the two 38.5 MW units. It is estimated that up to eight new production wells may be required, and preliminary targets for these have already been identified. Also, the electrical transmission system installed for the Phase I development will be modified by the installation of a second circuit and expansion of the switchyard at the Power Station. It is envisaged that the additional Phase II project units would enter commercial operations at 66MW in the first quarter of 2008. Figure 2 below shows a schematic diagram of

¹³ Installed capacity as per turbines nameplates.

¹⁴ Presented in third party engineering report “Value Added Report” dated 20 November 2009, by Sinclair Knight Merz (SKM). Page 19.

¹⁵ Presented in third party engineering report “Value Added Report” dated 20 November 2009, by Sinclair Knight Merz (SKM). Page 19.

¹⁶ As calculated in Table B.3.2.

one of the 38.5 MW power units built in Phase 2 of the project activity. The second 38.5 MW unit is a parallel unit, identical to the one below. Together these units provide 77 MW of rated power generation.

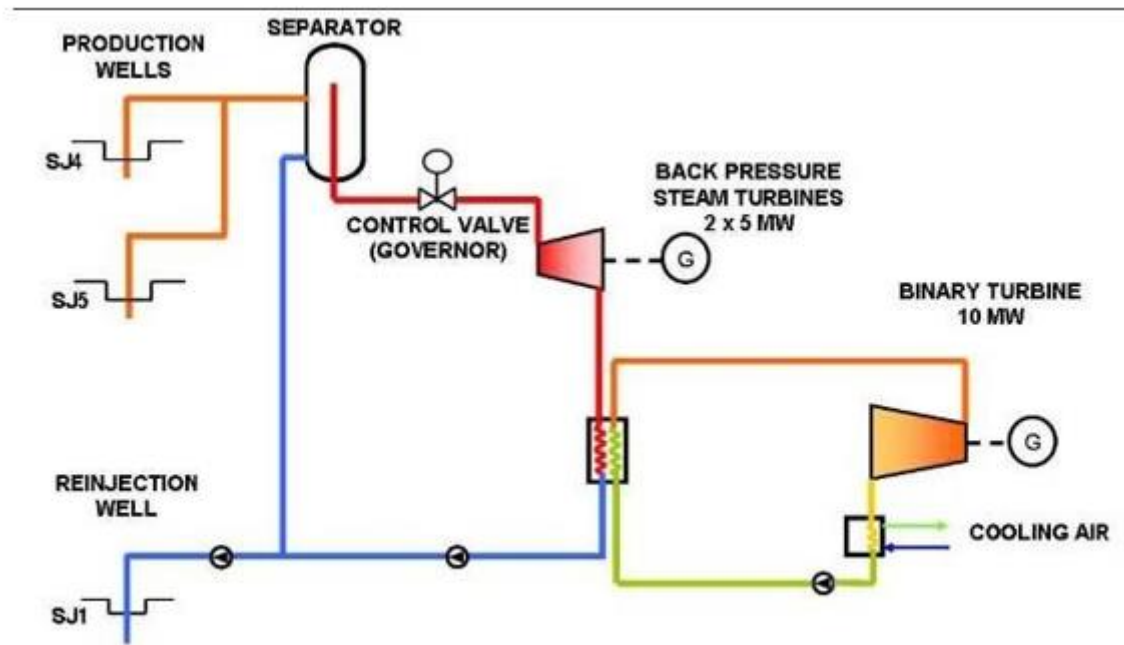

Figure 1. Phase I Diagram

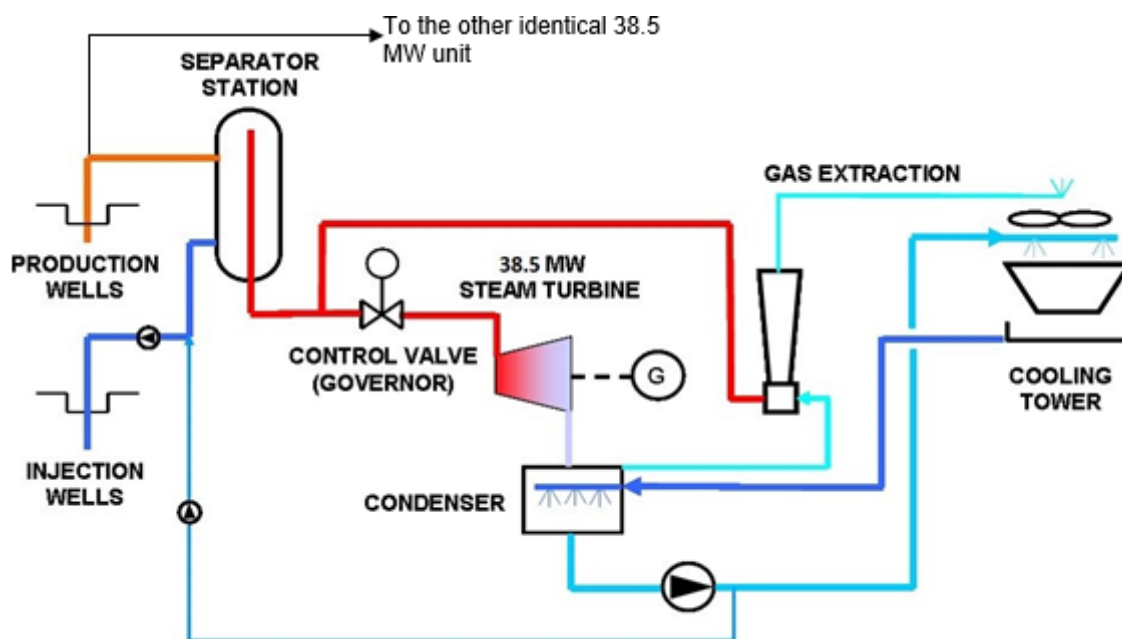

Figure 2. Phase 2 Diagram

Technology Transfer

The technology installed in the project activity has been used in a number of geothermal power projects around the world. Equipment for Phase 1 of the project is supplied by ACEC (of Belgium, now part of Alstom). The same equipment was installed in LaGeo’s geothermal power plant at Berlin, Departments of Usulután, in the Republic of El Salvador.

Furthermore, for project management, Polaris Geothermal Inc. has subcontracted a competent team with all the knowledge needed. These include Sinclair Knight Merz Ltd. from New Zealand and LaGeo from El Salvador.

Sinclair Knight Merz (SKM) is a well-known developer of geothermal projects. SKM has international experience in more than 15 countries, having developed over 75% of the geothermal projects outside the USA and all the projects carried out in the Philippines, Indonesia and New Zealand.

LaGeo has vast experience in the development and operation of geothermal plants in El Salvador. LaGeo manages and successfully operates two geothermal plants in El Salvador, Ahuachapán (Ausoles) y Berlín (Tronador). During the first years of operation, LaGeo was the company in charge of the maintenance and operations of the San Jacinto-Tizate plant, then the operation and maintenance was transferred to PENSA. Enel Green Power, from Italy, is one of the main shareholders of LaGeo. A contract has been signed between the project developer and LaGeo for the sale of the two turbo-generator units and associated equipment to be used in Stage 1 of Phase1. An additional contract to operate and maintain the plant for a period of time has also been signed with LaGeo.

B.2. Post-registration changes

B.2.1. Temporary deviations from the registered monitoring plan, applied methodologies, standardized baselines or other methodological regulatory documents

Not Applicable

B.2.2. Corrections

Not Applicable

B.2.3. Changes to the start date of the crediting period

Not Applicable

B.2.4. Inclusion of monitoring plan

Not Applicable

B.2.5. Permanent changes to the registered monitoring plan, or permanent deviation of monitoring from the applied methodologies, standardized baselines, or other methodological regulatory documents

Not Applicable

B.2.6. Changes to project design

Not Applicable

B.2.7. Changes specific to afforestation or reforestation project activity

Not Applicable

SECTION C. Description of monitoring system

This plan aims to monitor on a regular basis the GHG emissions of the San Jacinto-Tizate Geothermal Project from non-condensable gases and the from the Nicaraguan electricity grid. There are six main activities are to be performed within the monitoring process:

- 1 Calibration and maintenance of monitoring equipment and instruments;
- 2 Gathering of data from steam wells and power generation;
- 3 Calculation of GHG emission reductions;
- 4 Management and storage of data;
- 5 Supervision of the quality of the monitoring process; and
- 6 Issuance of reports for internal and external verification.

The table in Appendix 5 outlines these steps in detail.

Polaris Geothermal Inc. have created a local firm called Polaris Energy Nicaragua S.A. (the project developer as established on the PDD) to manage San Jacinto-Tizate Geothermal Project. This subsidiary will be the authority of the monitoring process.

San Jacinto Power SA hires a certified laboratory to perform high quality chemical sampling and analyses of water, gases and pollutants on a "Geothermic Laboratory", to perform sampling and chemical analysis activities of non-condensable gases (NCG).

The data required for determining the baseline GHG emissions is summarized in Tables in Section B.7.1 NCG sampling and analytical methods are described in the same tables.

The NCG data, expressed as a weight ration of gas / steam, will be retained in computer files together with other project monitoring data. Using steam flowrate data and gas-in-steam concentrations, the flow of each GHG can be calculated, according to the general formula:

$$\text{GHG FLOW (T/H)} = \text{STEAM FLOW (T/H)} \times \text{GAS-IN-STEAM (T GAS/T STEAM)}$$

NCG emissions all arise from the production well fluids. The well fluids are separated in a separator vessel and the steam is piped to the power station while the separated water (brine) is reinjected. The NCG remains with the steam portion. NCG discharges thus occur from the power plant itself, from the rock muffler at the vent station (where excess steam is vented to atmosphere) and from pipeline drains. The amount of emission can be estimated either from the mass flow coming from the production wells or from the flow to each of the discharge points.

Well mass flow output can be related to well head pressure and this will be checked for each well quarterly, using tracer dilution methods. This analysis also provides information to determine the steam and brine mass fractions. At the same time, the NCG content and composition will be determined. Well output versus well head pressure and NCG content do not change rapidly and quarterly analysis will be adequate for this purpose.

Steam system pressure will be recorded continuously at the power station. By off-line analysis, this can be related back to well head pressure and hence the mass flow production from each well can be determined and hence the NCG production. The results of this analysis will be consolidated and presented in a quarterly report.

The cumulative steam flow into the power station will be directly measured for each unit at the power station. This flow will be recorded regularly and a total quarterly mass flow obtained, from which the NCG discharge from the plant will be able to be determined. In the Stage 1 plant, almost the entire NCG discharge will be from the turbine exhaust silencers, with a small amount from drains that are downstream of the steam flow measurement point. When Stage 2 is commissioned, the total steam mass flow will still pass through the same flow measurement points, although the NCG will mostly then be discharged from dedicated high level vents. When Phase II is commissioned, additional steam flow measurement instrumentation will be provided for the two Phase II units and the NCG will primarily be discharged with the cooling tower plume.

There is no direct measurement of steam (and hence NCG) discharge from the rock muffler. However, this quantity can be determined from the vent valve position and the steam system pressure. Both parameters will be recorded continuously and periodically analysed off-line to obtain NCG mass flow, which will be determined on a quarterly basis.

The underflow to atmosphere from the pipeline drains, under normal conditions, will be measured during the plant commissioning programme. It will be assumed that this small flow will remain sensibly constant during normal operation and the NCG content will be added to the quarterly measured emissions.

EcoSecurities Ltd is the entity determining the monitoring plan and participating in the project as the Carbon Advisor. The individuals at EcoSecurities that prepared the monitoring methodology are Sonia Medina and Joanna Duthie as listed in Annex 1 of this document.

SECTION D. Data and parameters

D.1. Data and parameters fixed ex ante

Data/Parameter	GWP_{CH_4}
Unit	tCO _{2e} / tCH ₄
Description	Global Warming Potential of methane valid for the relevant commitment period.
Source of data	IPCC
Value(s) applied	For the first commitment period: 21.0 tCO _{2e} / tCH ₄ For the second commitment period: 25.0 t CO _{2e} /tCH ₄
Choice of data or measurement methods and procedures	IPCC Direct Global Warming Potential as defined in Climate Change 2007: working Group I: The Physical Science basis.
Purpose of data/parameter	The value is used for calculating project emissions (PE _{GP,y}) from CH ₄ mass fraction in geothermal steam sampling.
Additional comments	Nil

Data/Parameter	NCV _{i,y}	
Unit	TJ/Gg	
Description	Net calorific value (energy content) of fuel type <i>i</i> in year <i>y</i>	
Source of data	The following data sources may be used if the relevant conditions apply:	
	Data Source	Conditions for using the data source
	Values provided by the fuel supplier of the power plants in invoices	If data is collected from power plant operators (e.g. utilities)
	Regional or national average default values	If values are reliable and documented in regional or national energy statistics / energy balances
	IPCC default values at the lower limit of the uncertainty at a 95% confidence interval as provided in Table 1.2 of Chapter 1 of Vol. 2 (Energy) of the 2006 IPCC Guidelines on National GHG Inventories	
	Neither values from fuel supplier nor regional / national values are available, so the IPCC default values are used.	
Value(s) applied	Heavy Fuel Oil - 39.8 TJ/Gg Diesel - 41.4 TJ/Gg	
Choice of data or measurement methods and procedures	IPCC standard for diesel (lower limit of uncertainty at 95%) used as values are not available by fuel supplier and no reliable national default values are available.	
Purpose of data/parameter	Calculation of COEF _i .	
Additional comments	Applicable in the following cases: 1) Calculation of the simple OM, the simple adjusted OM, and the average OM in cases where fuel consumption data is available for all power plants / units.	

Data/Parameter	EF _{CO₂,i,y}	
Unit	tCO ₂ /TJ	
Description	CO ₂ emission factor of fuel type <i>i</i> in year <i>y</i>	
Source of data	The following data sources may be used if the relevant conditions apply:	
	Data Source	Conditions for using the data source
	Values provided by the fuel supplier of the power plants in invoices	If data is collected from power plant operators (e.g. utilities)
	Regional or national average default values	If values are reliable and documented in regional or national energy statistics / energy balances
	IPCC default values at the lower limit of the uncertainty at a 95% confidence interval as provided in Table 1.4 of Chapter 1 of Vol. 2 (Energy) of the 2006 IPCC Guidelines on National GHG Inventories	
	Neither values from fuel supplier nor regional / national values are available, so the IPCC default values are used.	
Value(s) applied	Heavy Fuel Oil - 75.5 tCO ₂ /TJ Diesel - 72.6 tCO ₂ /TJ	
Choice of data or measurement methods and procedures	IPCC standard for diesel (lower limit of uncertainty at 95%) used as values are not available by fuel supplier and no reliable national default values are available.	
Purpose of data/parameter	Calculation of COEF _i .	
Additional comments	Used to calculate OM and BM.	

Data/Parameter	FC _{i,j,y}
Unit	gallons
Description	Amount of fuel type <i>i</i> consumed by power plant <i>j</i> in year <i>y</i>
Source of data	Official publications from the Institute of Energy, INE.
Value(s) applied	Values are given in supporting calculation spreadsheet
Choice of data or measurement methods and procedures	The data is provided by the government owned national utility for the most recent three historical years at the time of the PDD submission (2016 -2018).
Purpose of data/parameter	Calculation of grid emission factor for baseline emissions.
Additional comments	Used to calculate OM and BM.

Data/Parameter	EG _{m,y}
Unit	MWh
Description	The electricity delivered to the grid by source <i>m</i>
Source of data	Official publications from the Institute of Energy, INE.
Value(s) applied	Values are given in supporting calculation spreadsheet
Choice of data or measurement methods and procedures	The data is provided by the government owned national utility for the most recent three historical years at the time of the PDD submission (2016 -2018).
Purpose of data/parameter	Calculation of grid emission factor for baseline emissions.
Additional comments	Used to calculate OM and BM.

D.2. Data and parameters monitored

Data/Parameter	$M_{\text{steam},y}$
Unit	t steam
Description	Quantity of steam produced in year y
Measured/calculated/default	Measured
Source of data	Direct measurement of steam
Value(s) of monitored parameter	6429842.56
Monitoring equipment	The steam quantity discharged should be measured with a Venturi flow meter (or other equipment with a least the same accuracy). Measurement of temperature and pressure upstream of the Venturi meter is required to define steam properties. The calculation of steam quantities should be conducted on a continuous basis and should be based on international standards. The measurement results should be summarized transparently in regular production reports.
Measuring/reading/recording frequency	Daily.
Calculation method (if applicable)	NA
QA/QC procedures	Quality is assured following plant established procedures, good practices, and training of operations personnel. Calibration, maintenance, and sampling is performed by a certified laboratory to the ASTM E 1675-95a and Norm ASTM E947-83 international standards.
Purpose of data/parameter	To calculate PES_y , the project emissions due to release of CO_2 and CH_4 from the produced steam during the year y .
Additional comments	Applicable to dry or flash steam geothermal power projects

Data/Parameter	$\omega_{\text{steam},CO_2,y}$
Unit	t CO_2 / t steam
Description	Average mass fraction of carbon dioxide in the produced steam in year y
Measured/calculated/default	Measured
Source of data	Direct measurement of CO_2 in steam
Value(s) of monitored parameter	Monthly values provided in spreadsheet
Monitoring equipment	Non-condensable gases sampling should be carried out at the steam field-power plant interface using ASTM Standard Practice E1675 for Sampling 2-Phase Geothermal Fluid for Purposes of Chemical Analysis (as applicable to sampling single phase steam only). The CO_2 and CH_4 sampling and analysis procedure consists of collecting NCG samples from the main steam line with glass flasks, filled with sodium hydroxide solution and additional chemicals to prevent oxidation. Hydrogen sulphide (H_2S) and carbon dioxide (CO_2) dissolve in the solvent while the residual compounds remain in their gaseous phase. The gas portion is then analyzed using gas chromatography to determine the content of the residuals including CH_4 . All alkanes concentrations are reported in terms of methane.
Measuring/reading/recording frequency	At least every three months and more frequently if necessary.
Calculation method (if applicable)	NA
QA/QC procedures	Quality is assured following plant established procedures, good practices, and training of operations personnel.

Purpose of data/parameter	To calculate PES _y , the project emissions due to release of CO ₂ and CH ₄ from the produced steam during the year y.
Additional comments	Applicable to dry or flash steam geothermal power projects

Data/Parameter	$\omega_{\text{steam,CH}_4,y}$
Unit	t CH ₄ / t steam
Description	Average mass fraction of methane in the produced steam in year y
Measured/calculated/default	Measured
Source of data	Direct measurement of CH ₄ in steam
Value(s) of monitored parameter	Monthly values provided in spreadsheet
Monitoring equipment	Non-condensable gases sampling should be carried out at the steam field-power plant interface using ASTM Standard Practice E1675 for Sampling 2-Phase Geothermal Fluid for Purposes of Chemical Analysis (as applicable to sampling single phase steam only). The CO ₂ and CH ₄ sampling and analysis procedure consists of collecting NCG samples from the main steam line with glass flasks, filled with sodium hydroxide solution and additional chemicals to prevent oxidation. Hydrogen sulphide (H ₂ S) and carbon dioxide (CO ₂) dissolve in the solvent while the residual compounds remain in their gaseous phase. The gas portion is then analyzed using gas chromatography to determine the content of the residuals including CH ₄ . All alkanes concentrations are reported in terms of methane.
Measuring/reading/recording frequency	At least every three months and more frequently if necessary.
Calculation method (if applicable)	NA
QA/QC procedures	Quality is assured following plant established procedures, good practices, and training of operations personnel.
Purpose of data/parameter	To calculate PES _y , the project emissions due to release of CO ₂ and CH ₄ from the produced steam during the year y.
Additional comments	Applicable to dry or flash steam geothermal power projects

Data/Parameter	$E_{\text{facility},y}$
Unit	MWh/yr
Description	Quantity of net electricity generation supplied by the project plant to the grid in year y
Measured/calculated/default	Calculated
Source of data	Electricity revenue meters connected to PENSA power substation
Value(s) of monitored parameter	765,635.12
Monitoring equipment	Electricity revenue meters
Measuring/reading/recording frequency	Continuous measurement and at least monthly recording.
Calculation method (if applicable)	The revenue meters measure energy automatically and continuously. They are programmed to integrate the instantaneous values every fifteen (15) minutes and accumulative values are automatically saved every fifteen minutes in the massive memory of the principal and back-up meter. Once a month, plant personnel download the data from the electricity meters <i>in situ</i> , and the data is used to prepare the energy bill. The official monthly file is archived together with a scanned copy of the electricity bill for future reference.

QA/QC procedures	Quality is assured following plant established procedures, good practices, and training of operations personnel. Also, there are two electricity meters installed in tandem, in case there is a problem with one. Calibration is performed by the national utility ENATREL. On a daily basis (24/7), the Shift Supervisor download all data from the revenue meters for the previous day. This file is then uploaded onto the Grid Operator’s Web Page (CNDC web page). See http://www.cndc.org.ni/index2.html . It is user password-protected. Recorded values are double checked with receipt of sales by the Operations Manager every three months.
Purpose of data/parameter	To calculate the baseline emissions (BE _y)
Additional comments	Data stored electronically until at least two years after the end of the crediting period.

D.3. Implementation of sampling plan

There is no sampling involved in this project activity.

SECTION E. Calculation of emission reductions or net anthropogenic removals

E.1. Calculation of baseline emissions or baseline net removals

The electric power to be generated by the project activity and delivered to the grid during the current monitoring period is 0 MWh. The baseline emission factor was calculated to be 0.4526 t CO₂e/MWh. The baseline emissions are calculated as follows:

$$BE_y = EG_{PJ,y} \times EF_{grid,CM,y} = 0 \text{ MWh} \times 0.4526 \text{ t CO}_2\text{e/MWh} = 0 \text{ tCO}_2$$

Therefore, Baseline Emissions (BE_y) = 0 tCO₂e (Round-down value)

E.2. Calculation of project emissions or actual net removals

$$PE_y = PE_{FF,y} + PE_{GP,y} + PE_{HP,y} = 0 + (W_{steam,CO_2,y} + W_{steam,CH_4,y} \times GWP_{CH_4}) \times M_{steam,y} + 0$$

$$PE_{GP,y} = PE_{dry \text{ or flash steam},y} + PE_{binary,y}$$

$$PE_{binary,y} = 0, \text{ therefore } PE_{GP,y} = PE_{dry \text{ or flash steam},y}$$

Detailed calculation of project emissions have been provided in emissions reductions spreadsheet.

$$M_{steam,y} = 0 \text{ tonnes}$$

$$PE_{GP,y} = 0 \text{ tCO}_2$$

Therefore, Project Emissions (PE_y) = 0 tCO₂e (Round-up value)

E.3. Calculation of leakage emissions

In accordance with ACM0002 Version 4.0, there is no leakage caused by the proposed project activity.

Therefore, Leakage Emissions (LE_y) = 0 tCO₂e

E.4. Calculation of emission reductions or net anthropogenic removals

	Baseline GHG emissions or baseline net GHG removals (t CO ₂ e)	Project GHG emissions or actual net GHG removals (t CO ₂ e)	Leakage GHG emissions (t CO ₂ e)	GHG emission reductions or net anthropogenic GHG removals (t CO ₂ e)			
				Before 01/01/2013	From 01/01/2013 until 31/12/2020	From 01/01/2021	Total amount
Total	0	0	0	0	0	0	0

E.5. Comparison of emission reductions or net anthropogenic removals achieved with estimates in the registered PDD

Amount achieved during this monitoring period (t CO ₂ e)	Amount estimated ex ante for this monitoring period in the PDD (t CO ₂ e)
0	397,598

E.5.1. Explanation of calculation of “amount estimated ex ante for this monitoring period in the PDD”

Considering the annual average emission reductions as per the registered PDD which is 280,703 tCO₂e per year, the number of days covered during the current monitoring period comes out to be 517 days, based upon which the estimated emission reductions attributed to this monitoring period comes out to be 397,598 tCO₂e. The detailed calculation can be referred from the emission reduction sheet.

E.6. Remarks on increase in achieved emission reductions

Actual emission reductions achieved are 0 tCO₂e, which is lower than the estimated emission reductions. This variation is majorly due to the lower generation during the current verification period owing to certain natural conditions which are beyond the control of PP.

E.7. Remarks on scale of small-scale project activity

The project activity remains as a large scale project activity throughout the crediting period.

Annex-1

Annex 4. Monitoring Procedures

Annex 4. Monitoring Procedures								
	Activity		Sub-Activity	Responsible		Periodicity	References	Report
1	Calibration and maintenance of monitoring of equipment and instruments	A	Preparation of sampling equipment and instruments	Polaris Energy Nicaragua S.A.	Manager Director	According with standards	ASTM E 1675-95a; "Standard Practice for Sampling Two-Phase Geothermal Fluid for Purposes of Chemical Analysis".	SJG-CM-01
		B	Calibrate and maintain laboratory equipment and instruments	Polaris Energy Nicaragua S.A.	Manager Director	According with standards	The certified laboratory calibrates and maintains the equipment periodically as per manufacturer protocols.	
		C	Calibration and Maintenance of electricity meter	ENATREL (national electricity utility)	ENATREL	At the start of the project and then accordingly with their operations requirements.	The Grid Operator calibrates and maintains the electricity meter in line with the standards of Norms of Commercial Operation of the National Dispatch Center.	-
2	Gathering of data from steam wells and power generation	A	Sampling steam	Polaris Energy Nicaragua S.A.	Project Manager for San Jacinto-Tizate Project	Every three months	ASTM E 1675-95a; "Standard Practice for Sampling Two-Phase Geothermal Fluid for Purposes of Chemical Analysis" and Section B.7 in PDD.	SJG-GD-01
		B	Analyse CO2 content of the steam	Polaris Energy Nicaragua S.A.	Project Manager for San Jacinto-Tizate Project	Every three months	Norm ASTM E 1675 and Norm ASTM E947-83 (steam sampling)	
		C	Analyse CH4 content of the steam	Polaris Energy Nicaragua S.A.	Project Manager for San Jacinto-Tizate Project	Every three months	Norm ASTM E 1675 and Norm ASTM E947-83 (steam sampling)	

		D	Report the findings of the chemical analysis	Polaris Energy Nicaragua S.A.	Project Manager for San Jacinto-Tizate Project	Every three months	Section B.7	
		E	Read electricity generation data from meter	Polaris Energy Nicaragua S.A.	Superintendent	daily	Section B.7	SJG-GD-02
		F	Measure the steam flow	Polaris Energy Nicaragua S.A.	Superintendent	daily	Section B.7	
		G	Report the data from the readings and measure	Polaris Energy Nicaragua S.A.	Superintendent	daily	Section B.7	
3	Calculation of GHG emission reductions	A	Calculate the project activity emissions from NCG discharged to the atmosphere due to the project activity	Polaris Energy Nicaragua S.A.	Operations Supervisor	At the end of each monitoring period	Section B6.3	
		B	Calculate the baseline emissions offset from the grid	Polaris Energy Nicaragua S.A.	Operations Supervisor	At the end of each monitoring period	Section B6.3	-
		C	Calculate the emission reductions	Polaris Energy Nicaragua S.A.	Operations Supervisor	At the end of each monitoring period	Section B6.3	-
4	Management and storage of data	A	Archive data from steam generation	Polaris Energy Nicaragua S.A.	Operations Supervisor	Every three months	Section B.7	-
		B	Archive data from power generation	Polaris Energy Nicaragua S.A.	Operations Supervisor	Every three months	Section B.7	-
		C	Manage the data and information	Polaris Energy Nicaragua S.A.	Operations Supervisor	Monthly	Section B.7	-
		D	Storage the data and information	Polaris Energy Nicaragua S.A.	Operations Supervisor	Monthly	The data and information should be stored until two years after the crediting period has finished	-

5	Supervision of the quality of the monitoring process	A	Review all reports are being performed as mentioned in this plan	Polaris Energy Nicaragua S.A.	Operations Manager	Every three months	Section B.7	SJG-SMP-01
		B	Performance evaluation of monitoring personnel	Polaris Energy Nicaragua S.A.	Operations Manager	Annually	Section B.7	
		C	Issue a evaluation report of the monitoring process	Polaris Energy Nicaragua S.A.	Operations Manager	Annually	Section B.7	
		D	Assure the periodical training of personnel mentioned in this plan within Polaris Energy Nicaragua S.A.involving in the monitoring process	Polaris Energy Nicaragua S.A.	Operations Manager	Every six months, or when new Superintendent is hired	Section B.7	SJG-SMP-02
6	Issuance of reports for internal and external verification	A	Produce a Monitoring Management report summarising the reports mentioned above	Polaris Energy Nicaragua S.A.	Operations Manager	At the end of each monitoring period	Section B.7	SJG-MM-01
		B	Produce a report of the GHG emission reductions	Polaris Energy Nicaragua S.A.	Operations Manager	At the end of each monitoring period	Section B.7	SJG-GHG-01

- - - - -

Document information

<i>Version</i>	<i>Date</i>	<i>Description</i>
08.0	6 April 2021	Revision to: <ul style="list-style-type: none"> • Reflect the “Clarification: Regulatory requirements under temporary measures for post-2020 cases” (CDM-EB109-A01-CLAR).
07.0	31 May 2019	Revision to: <ul style="list-style-type: none"> • Ensure consistency with version 02.0 of the “CDM project standard for project activities” (CDM-EB93-A04-STAN); • Add a section on remarks on the observance of the scale limit of small-scale project activity during the crediting period; • Add "changes specific to afforestation or reforestation project activity" as a possible post-registration changes; • Clarify the reporting of net anthropogenic GHG removals for A/R project activities between two commitment periods; • Make editorial improvements.
06.0	7 June 2017	Revision to: <ul style="list-style-type: none"> • Ensure consistency with version 01.0 of the “CDM project standard for project activities” (CDM-EB93-A04-STAN); • Make editorial improvements.
05.1	4 May 2015	Editorial revision to correct version numbering.
05.0	1 April 2015	Revisions to: <ul style="list-style-type: none"> • Include provisions related to delayed submission of a monitoring plan; • Provisions related to the Host Party; • Remove reference to programme of activities; • Overall editorial improvement.
04.0	25 June 2014	Revisions to: <ul style="list-style-type: none"> • Include the Attachment: Instructions for filling out the monitoring report form (these instructions supersede the "Guideline: Completing the monitoring report form" (Version 04.0)); • Include provisions related to standardized baselines; • Add contact information on a responsible person(s)/ entity(ies) for completing the CDM-MR-FORM in A.6 and Appendix 1; • Change the reference number from <i>F-CDM-MR</i> to <i>CDM-MR-FORM</i>; • Editorial improvement.
03.2	5 November 2013	Editorial revision to correct table in page 1.
03.1	2 January 2013	Editorial revision to correct table in section E.5.

<i>Version</i>	<i>Date</i>	<i>Description</i>
03.0	3 December 2012	Revision required to introduce a provision on reporting actual emission reductions or net GHG removals by sinks for the period up to 31 December 2012 and the period from 1 January 2013 onwards (EB 70, Annex 11).
02.0	13 March 2012	Revision required to ensure consistency with the "Guidelines for completing the monitoring report form" (EB 66, Annex 20).
01.0	28 May 2010	EB 54, Annex 34. Initial adoption.

Decision Class: Regulatory
Document Type: Form
Business Function: Issuance
Keywords: monitoring report
