



**Verified Carbon
Standard**

SHANDONG TAIPINGSHAN WIND FARM PROJECT

Document Prepared by CGN Carbon Asset Management (Beijing) Co.,
Ltd.

Project Title	<i>Shandong Taipingshan Wind Farm Project</i>
Version	<i>02</i>
Report ID	<i>CGN-202103</i>
Date of Issue	<i>18/05/2021</i>
Project ID	<i>PL1189</i>
Monitoring Period	<i>24/04/2012-31/12/2015</i>
Prepared By	<i>CGN Carbon Asset Management (Beijing) Co., Ltd.</i>
Contact	<i>Area 12 of Advanced Business Park, No. 188 west of South 4th Ring Road, No.2 Building, Beijing, The People's Republic of China</i> <i>Telephone: +86 10 63705765</i> <i>Email:cgnwind@163.com</i>

CONTENTS

1	PROJECT DETAILS.....	3
1.1	Summary Description of the Implementation Status of the Project.....	3
1.2	Sectoral Scope and Project Type.....	3
1.3	Project Proponent.....	4
1.4	Other Entities Involved in the Project.....	4
1.5	Project Start Date.....	4
1.6	Project Crediting Period.....	4
1.7	Project Location.....	4
1.8	Title and Reference of Methodology.....	5
1.9	Participation under other GHG Programs.....	6
1.10	Other Forms of Credit.....	6
1.11	Sustainable Development.....	6
2	SAFEGUARDS	7
2.1	No Net Harm.....	7
2.2	Local Stakeholder Consultation.....	8
2.3	AFOLU-Specific Safeguards.....	10
3	IMPLEMENTATION STATUS	11
3.1	Implementation Status of the Project Activity	11
3.2	Deviations.....	12
3.3	Grouped Projects.....	12
4	DATA AND PARAMETERS.....	12
4.1	Data and Parameters Available at Validation.....	12
4.2	Data and Parameters Monitored.....	13
4.3	Monitoring Plan.....	16
5	QUANTIFICATION OF GHG EMISSION REDUCTIONS AND REMOVALS	19
5.1	Baseline Emissions	19
5.2	Project Emissions.....	23
5.3	Leakage.....	23
5.4	Net GHG Emission Reductions and Removals.....	23

1 PROJECT DETAILS

1.1 Summary Description of the Implementation Status of the Project

Shandong Taipingshan Wind Farm Project (hereinafter referred to as the proposed project) is to utilize wind resources for electricity generation through the construction of a wind farm with a total capacity of 49.3MW and an 110kV substation in Weifang City, Shandong Province, P. R. China. The electricity generated from the project will be sold to North China Power Grid (NCPG). The proposed project will achieve obvious greenhouse gas (GHG) emission reductions through the displacement of electricity delivered by North China Power Grid which is a fossil-fuel dominated grid. The proposed project is invested and developed by Anqiu Taipingshan Wind Power Co., Ltd..

The proposed project is located in Weifang City, Shandong Province, P. R. China. The proposed project involves the installation of 58 wind turbines with capacity of 850 kW each, which amount to a total installed capacity of 49.3MW. The proposed project is constructed and operated by Anqiu Taipingshan Wind Power Co., Ltd.. The estimated annual net electricity generation supplied to the grid is 91,030.5 MWh and the annual full-load operation time amount to 1,846 h per year. The estimated emission reduction is 84,740 tCO_{2e} annually.

The project started construction on 11/08/2009. The first batch of generating units started commercial operation on 27/04/2010. The expected operation period of the Project is 20 years as stated in the registered VCS PD Version 02 dated 28/12/2013 and registered CDM PDD Version 05 dated 12/04/2012. The first renewable crediting period of the project updated from 27/04/2010- 23/04/2012 to 27/04/2010-26/04/2020.

The project has been registered as VCS project with Ref. VCS1189 and VCUs of 180,005tCO_{2e} have been issued for the monitoring period from 27/04/2010- 23/04/2012. The project also has been registered as CDM project with Ref. 5659.

The total emission reductions achieved in this monitoring period (24/04/2012-31/12/2015) were 307,768 tCO_{2e}.

1.2 Sectoral Scope and Project Type

Sectoral Scope 1: Energy Industry (renewable/non-renewable sources)

Project type: Energy industries (renewable/non-renewable sources)

The project is not a grouped project.

1.3 Project Proponent

Organization name	<i>Anqiu Taipingshan Wind Power Co., Ltd.</i>
Contact person	<i>Shi Lei</i>
Title	<i>CDM office director</i>
Address	<i>Area 12 of Advanced Business Park, No. 188 west of South 4th Ring Road, No.2 Building, Beijing, The People's Republic of China</i>
Telephone	+86 10 63705765
Email	cgnwind@163.com

1.4 Other Entities Involved in the Project

There are no other entities involved.

1.5 Project Start Date

27/04/2010(commisioning start date)

1.6 Project Crediting Period

In the registered PD, the crediting period is described as from 27/04/2010 to 23/04/2012. A deviation is requested for the crediting period. The project is registered under VCS Standard Version 3.4 and completed validation before 19/03/2020. thus, it remains eligible to apply the crediting period requirements under VCS Standard Version 3.4 which shall be a maximum of ten years and may be renewed at most twice, so the first renewable crediting period of the project should be updated from 27/04/2010 to 23/04/2012 to 27/04/2010 to 26/04/2020.

Therefore, the project crediting period is ten years, twice renewable for a total of 30 years. However, as the project is also registered as a CDM project with a seven year twice renewable project crediting period and furthermore, the project has the lifetime of 20 years, it is not eligible for VCU issuance beyond 26/04/2030.

1.7 Project Location

The proposed project is in Weifang City, Shandong Province, P. R. China. The project has geographical coordinates with east longitude from 118°42'46"E to 118°50'27"E and north latitude from 36°10'20"N to 36°13'30"N. The figure A1 and A2 shows the geographical location of the proposed project.

Figure A1. The location of the proposed project in the map of P. R. China

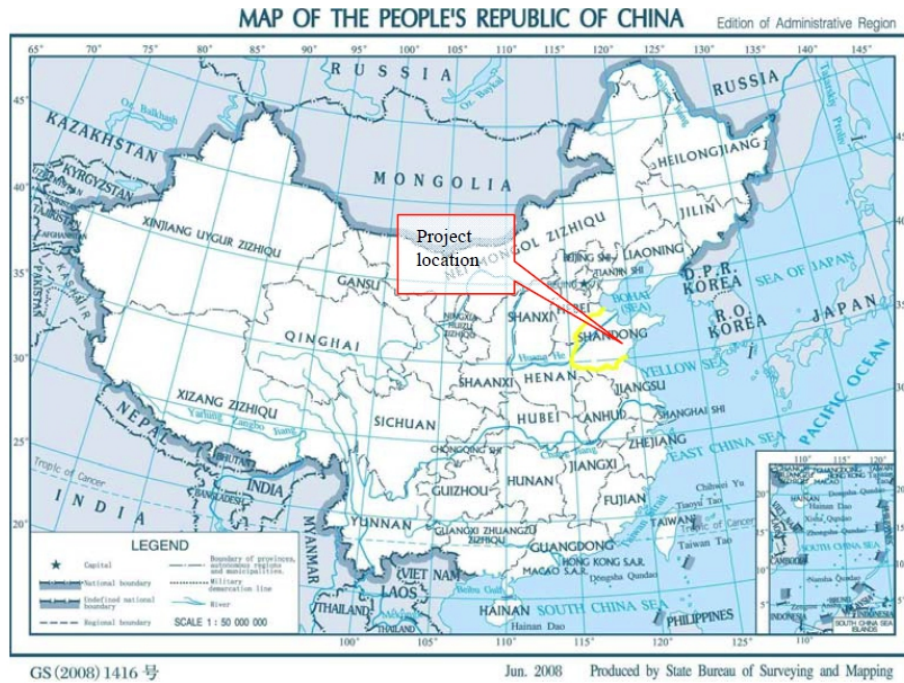

Figure A2. The proposed project on the map of Shandong Province and Wendeng County



1.8 Title and Reference of Methodology

The approved methodology applied in the proposed project activity is ACM0002 (version 12.2.0) – “Consolidated baseline methodology for grid-connected electricity generation from renewable sources”.

“Tool for the demonstration and assessment of additionality (version 05.2.1)” and

“Tool to calculate the emission factor for an electricity system (version 02.2.1)” is also applied in the proposed project.

Reference: <http://cdm.unfccc.int/methodologies/PAmethodologies/approved>

1.9 Participation under other GHG Programs

The project has been registered as CDM project and the registration number is 5659, the first CDM crediting period is from 24/04/2012 to 23/04/2019, and the crediting period has been successfully renewed on 27/04/2019 with the 2nd CDM crediting period from 24/04/2019 to 23/04/2026. The project has been registered as VCS project with Ref. VCS1189 and VCU of 180,005tCO_{2e} have been issued for the monitoring period from 27/04/2010- 23/04/2012.

1.10 Other Forms of Credit

Emission Trading Programs and Other Binding Limits

The project has been registered as VCS project with Ref. VCS1189 and VCU of 180,005tCO_{2e} have been issued for the monitoring period from 27/04/2010- 23/04/2012.

The GHG emission reductions generated by the project from 24/04/2012 to 31/12/2015 will not be used for compliance with emission trading programs or to meet binding limits on GHG emissions.

All credits from 24/04/2012 to 31/12/2015 will be claimed under VCS program as VCU for the project to avoid double counting.

Other Forms of Environmental Credit

The project hasn't sought or received another form of environmental credits.

1.11 Sustainable Development

The proposed project makes contribution to the local sustainable development as follows:

1. GHG emission reduction

The proposed project activity will achieve obvious GHG emission reductions by avoiding CO₂ emissions, as grid-connected fossil fuel-fired power dominates in the NCPG.

2. Pollutants emission reduction through replacing fossil fuel combustion

The proposed project utilizes wind energy for generating electricity which would have been generated through alternate fuels (fossil fuel) based power plants, contributing to reduction in specific emissions including GHG emissions. Thus reduce fossil fuel consumption and avoid pollutants emission, such as sulfur dioxide and dust, brought by fossil fuel combustion.

Therefore, the proposed project has obvious environmental benefits. Thus reduce fossil fuel consumption and avoid pollutants emission, such as sulfur dioxide and dust, brought by fossil fuel combustion. Therefore, the proposed project has obvious environmental benefits.

3. Employment opportunities

The proposed project utilizes wind energy for generating electricity which would have been generated through alternate fuels (fossil fuel) based power plants, contributing to reduction in specific emissions including GHG emissions. Thus reduce fossil fuel consumption and avoid pollutants emission, such as sulfur dioxide and dust, brought by fossil fuel combustion. Therefore, the proposed project has obvious environmental benefits.

4. Economic development

The proposed project leads to an investment of about 522.3 million to a developing region which otherwise would not have happened in the absence of project activity. The generated electricity is fed into the NCPG, thereby improving the grid frequency and availability of electricity to the local stakeholders. This attracts new opportunities for industries and economic activities to be setup in the area thereby resulting in greater local employment, ultimately leading to overall development. Otherwise the construction of the wind farm will promote local economy by contributing to local government with more tax revenues through selling power generation (about 3.6 million per year).

2 SAFEGUARDS

2.1 No Net Harm

The environmental impact assessment for this project was carried out by Shandong Academy of Environmental Science in December 2007 and approved by Shandong Provincial Environmental Protection Bureau on 11/01/2008. The approval number is Luhuanshen [2008] 3 A summary of the report is illustrated as below:

Ambient air

The impact on ambient air quality of the proposed project is mainly from dust during construction stage. The excavation work is the primary emission source, however, it is a ground source and the particle size is quite large so that dust will deposit quickly on the ground. Immediately replant the areas where construction has completed, and by sprinkling water frequently and timely clearing can reduce the dust pollution. When the project is in operational period, there will be no air pollutions. In conclusion, the proposed project will not pose any threat on the quality of ambient air.

Impact from noise

There is some noise during the operation of wind turbines. The equipments and techniques with lower noise will be chosen to apply. Improvement on construction process and strengthening of equipment maintenance is emphasized. Noise Limits in Construction site (GB12523-90) and Emission standard for industrial enterprise noise at boundary (GB12348-2008) Level II noise standard would be fulfilled during the construction and operational period. Besides, some noise control measures on the noise source control and sensitive object protection would be taken to mitigate the noise at the maximum limit. Consequently, the noise of operation has little impact to the surrounding environment. Hence, the noise will not impact the work and daily life of local residents.

Electromagnetic impact

The operation of the wind farm will generate electromagnetic pollution, whereas the pollution is slight.

Some measures on the prevention and control of electromagnetic influence, for example, strengthen the training on the electromagnetic knowledge for the workers and organise and manage the work time, will be taken to reduce the electromagnetic impact during the operation phase. In addition, the wind turbines are very far from local residents and village. Therefore, the electronic magnetic pollution to the surrounding environment is insignificant.

Impact from Solid waste

There is mainly some waste of stone, bricks or domestic waste in the construction stage and basically no solid waste in the operational period. Solid waste will be collected and handled properly. Hence, it will not result any environmental impact.

Impact from Wastewater

Wastewater is mainly domestic wastewater. Wastewater quantity is fairly small and treatment methods will be applied for on-site primary treatment, and then the wastewater will be treated together with the local wastewater. Small-scale septic tanks should be built on the site, through which the discharging wastewater can reach the Water quality standard for urban miscellaneous water consumption (GB/T18920-2002). Therefore, the impact of wastewater is limited and mitigated.

No migrating birds have been found in the project field. Therefore, the project is not located on the passage of migrating birds, and the project construction will not influence the migration of birds.

2.2 Local Stakeholder Consultation

Local stakeholders Consultation during the project preparation stage:

Comments on the construction of the proposed project is invited through means of putting up a notice and holding stakeholder meeting to guarantee the successful implementation of proposed project with the interest of stakeholder being taken into account.

The project developer conducted a survey among the potential stakeholders, collecting public opinion regarding the proposed project activity. 50 copies of questionnaires were all received. Among the interviewees, there were 22 farmers, 13 workers, 2 are officers, 4 are teachers and 9 others with other occupation; 28 of them have educational level of middle school, 14 of high school, 4 of technical secondary school and 4 of collage. The questions regarding the proposed project were mainly as follows:

- a) How do you think of the local environmental quality in general?
- b) Is there any electromagnetic radiation disturbance when you watch TV?
- c) Do you think the construction of the project will have any negative effect on you and your family?
- d) Will the project promote the local economy?
- e) How do you think the project will affect the acoustic environment (noise) quality?
- f) What is your most concerned environmental issue during the construction and operation of the project?
- g) Do you favour the construction of the project?
- h) Do you have any advice about the selection of environmental protection measures?
- i) Do you have any other suggestions to the proposed project?

The summary of survey is listed as the following:

- 35 (70%) of them think the local environmental quality is very well, 15(30%) of them think it is general;
- All (100%) of them currently do not experience electromagnetic interference when watching TV at home;
- 47 (94%) of them think there will not be any negative impacts on their everyday life, and the remainder is unsure;
- All (100%) of them think the proposed project will help improve their living and/or working environment;

- All (100%) of them are unsure whether the proposed project will make noise;
- Regarding the construction and operation of the propose project, 22 (44%) of them are most concerned with electromagnetic interference, 28 (56%) of them are most concerned with the noise level, and none of them are most concerned with wastewater from the project;
- All (100%) of them support the implementation of the proposed project.

During the survey local residents support the propose project as they showed in the questionnaires. Some people express their concerns about the negative impacts of the project, but they don't think it is serious. About the environment impacts of the project, the requirements in the EIA report will be strictly conducted by the project owner and be supervised by the municipal environmental protection bureau. Therefore, the proposed project can be carried out as planned.

Local stakeholder Consultation during the project implementation stage:

The project owner has set out the mechanism for on-going communication with local stakeholders and the communications with local stakeholders are being carried out at periodic intervals.

Firstly, stakeholders were informed of the status and progress of the project through the bulletin board on the village committee, and their comments can be recorded in the village committee's complaint book. This information is fed back to the project proponent by the contact person for a timely response.

Secondly, stakeholders can communicate and give feedback directly to the project proponent at any time through the published phone number of contact person.

Finally, the contract person of project owner also meet local villagers to collect their commetns and suggestions yearly.

During this monitoring period, the project carried out the communication with local stakeholders in line with the mechanism. Village committee's complaint book were quarterly checked by the contact person, and the contact person visited the villages in Aug 2012, Sep 2013, Aug 2014, Sep 2015 to communicate with stakeholders. Meanwhile, the local authority has also conducted spot checks on the implementation of the project yearly. There are no negative comments received for the project during this monitoring period. In line with VCS requirements all the processed have been implemented to receive comments from local stakeholders as well as communicate with them.

2.3 AFOLU-Specific Safeguards

The project is not AFOLU project.

3 IMPLEMENTATION STATUS

3.1 Implementation Status of the Project Activity

The project employed standard wind power generation technology. It installed 58 wind turbines with capacity of 850kW each, adding up to a total installed capacity of 49.3 MW. The main specifications of the turbine/generator are listed as below Table:

Item	Unit	Index
Rated capacity	kW	850
Number of blades		3
Rotor diameter	m	58
Cut-in speed	m/s	3.0
Rated wind speed	m/s	16
Cut-off speed	m/s	21
Height of hub	m	65
Rated voltage	V	690

The technology diagram of the Project is as follows:

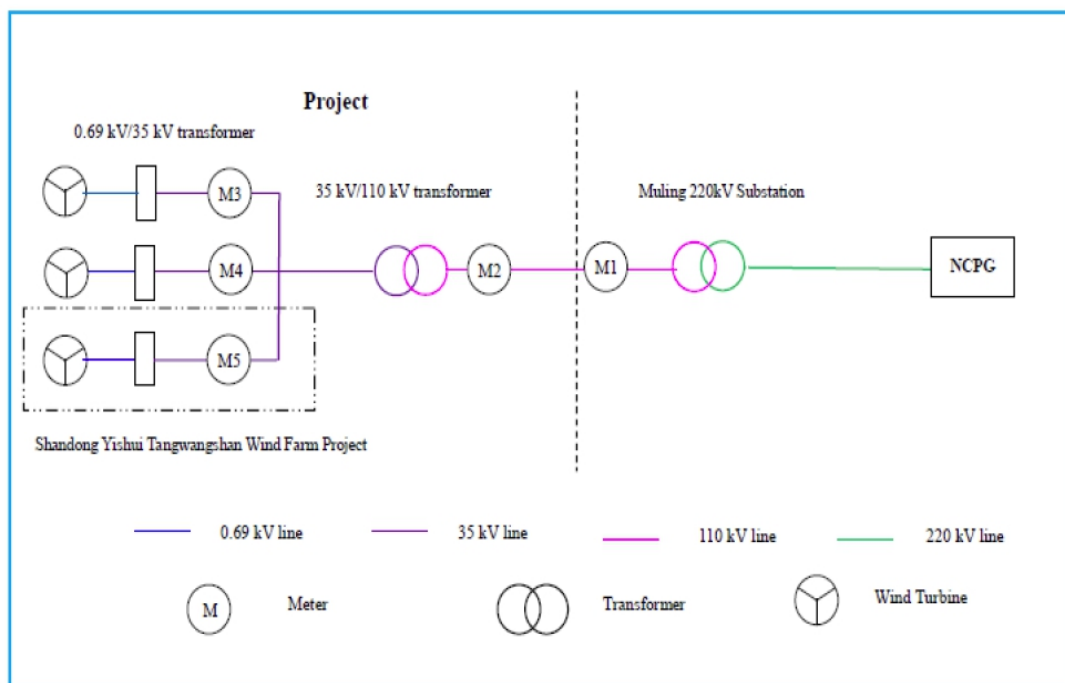

The project started construction on 11/08/2009. The first batch of generating units started commercial operation on 27/04/2010. The expected operation period of the Project is 20 years as stated in the registered CDM PDD Version 05 dated 12/04/2012.

The electricity generated from the Project is delivered to Shandong Power Grid, an integral part of the North China Power Grid (NCPG). During this monitoring period, there was no significant malfunction or any emergency occurred for the Project during this monitoring period. No events occurred during this monitoring period which may impact the applicability of the methodology.

3.2 Deviations

2.3.1 Methodology Deviations

There is no methodology deviations applied during this monitoring period.

2.3.2 Project Description Deviations

In the registered PD, the crediting period is described as from 27/04/2010 to 23/04/2012. A deviation is requested for the crediting period in the registered PD. The project is registered under VCS Standard Version 3.4 and completed validation before 19/03/2020. Thus, it remains eligible to apply the crediting period requirements under VCS Standard Version 3.4 which shall be a maximum of ten years and may be renewed at most twice, so the first renewable crediting period of the project should be updated from 27/04/2010 to 23/04/2012 to 27/04/2010 to 26/04/2020.

3.3 Grouped Projects

The project is not a grouped project.

4 DATA AND PARAMETERS

4.1 Data and Parameters Available at Validation

Data / Parameter	$EF_{grid,CM,y}$
Data unit	tCO ₂ / MWh
Description	Combined margin emission factor for grid connected power generation in year y
Source of data	Registered CDM PDD with Ref No.5659
Value applied	0.9309
Justification of choice of data or description of measurement methods	Refer to the registered CDM PDD with Ref No.5659

and procedures applied	
Purpose of Data	Calculation of baseline emissions
Comments	The data is calculated ex-ante according to the applied tool.

4.2 Data and Parameters Monitored

Data / Parameter	$EG_{\text{Facility},y}$												
Data unit	MWh												
Description	Quantity of net electricity generation supplied by the project to the Grid in year y.												
Source of data	Calculation by $EG_{\text{export},y}$ minus $EG_{\text{import},y}$												
Description of measurement methods and procedures to be applied	Calculated based on the measurement results of $EG_{\text{output},y}$ minus $EG_{\text{import},y}$. The project operator is responsible for recording such data.												
Frequency of monitoring/recording	Continuously measurement and monthly recording												
Value monitored	<table border="1"> <thead> <tr> <th>Period</th> <th>$EG_{\text{Facility},y}$ (MWh)</th> </tr> </thead> <tbody> <tr> <td>24/04/2012 - 31/12/2012</td> <td>63,143.59</td> </tr> <tr> <td>01/01/2013- 31/12/2013</td> <td>87,108.69</td> </tr> <tr> <td>01/01/2014- 31/12/2014</td> <td>90,131.24</td> </tr> <tr> <td>01/01/2015- 31/12/2015</td> <td>90,231.25</td> </tr> <tr> <td>Total</td> <td>330,614.77</td> </tr> </tbody> </table>	Period	$EG_{\text{Facility},y}$ (MWh)	24/04/2012 - 31/12/2012	63,143.59	01/01/2013- 31/12/2013	87,108.69	01/01/2014- 31/12/2014	90,131.24	01/01/2015- 31/12/2015	90,231.25	Total	330,614.77
Period	$EG_{\text{Facility},y}$ (MWh)												
24/04/2012 - 31/12/2012	63,143.59												
01/01/2013- 31/12/2013	87,108.69												
01/01/2014- 31/12/2014	90,131.24												
01/01/2015- 31/12/2015	90,231.25												
Total	330,614.77												
Monitoring equipment	Please refer to the monitoring equipment information in the table of parameters $EG_{\text{export},y}$, $EG_{\text{import},y}$. Please refer to the monitoring equipment information in the table of parameters.												
QA/QC procedures to be applied	The electricity generation by the proposed project will be monitored and recorded. The project operator is responsible for recording such data.												
Purpose of the data	Baseline Emission calculation												
Calculation method	Calculated based on the measurement results of $EG_{\text{export},y}$ minus $EG_{\text{import},y}$												
Comments	-												

Data / Parameter	$EG_{\text{export},y}$
Data unit	MWh
Description	Electricity supplied to the grid by the Project in year y.
Source of data	The readings of the meter M1、M3、M4、M5 at the connection point

Description of measurement methods and procedures to be applied	<p>between the proposed project and the Grid</p> <p>M1 as the main meter at Muling 220kV substation (M2 as the back-up meter in the wind farm) which use to monitor the total electricity supplied to the grid by the proposed project and another project (Shandong Tangwangshan Wind Farm Project, hereafter referred to Project B).</p> <p>M3 and M4 installed at the low voltage side of 35kV/110kV substation on the project site use to monitor the electricity supplied to the grid by the proposed project, M5 installed at the low voltage side of 35kV/110kV substation on the project site use to monitor the electricity supplied to the grid by the project B, All the meters are bi-direction meters with accuracy of 0.5s and the calibration accuracy is once a year in line with the national rules.</p> <p>For cross checking of the electricity exported by the proposed project against meter readings from M1 and M5, the following equation will be applied.</p> $EG_{\text{export},y} = EG_{A,y} / (EG_{A,y} + EG_{B,y}) * EG_{\text{output},y}$ <p>Electricity supplied to the grid by the proposed project ($EG_{\text{export},y}$) is cross checked with the electricity sales receipts issued by the grid company</p>												
Frequency of monitoring/recording	Continuously measurement and monthly recording												
Value monitored	<table border="1" data-bbox="618 1142 1333 1415"> <thead> <tr> <th data-bbox="618 1142 1027 1220">Period</th> <th data-bbox="1027 1142 1333 1220">EG_{output,y} (MWh)</th> </tr> </thead> <tbody> <tr> <td data-bbox="618 1220 1027 1255">24/04/2012 - 31/12/2012</td> <td data-bbox="1027 1220 1333 1255">63,380.31</td> </tr> <tr> <td data-bbox="618 1255 1027 1291">01/01/2013- 31/12/2013</td> <td data-bbox="1027 1255 1333 1291">87,622.61</td> </tr> <tr> <td data-bbox="618 1291 1027 1327">01/01/2014- 31/12/2014</td> <td data-bbox="1027 1291 1333 1327">90,858.12</td> </tr> <tr> <td data-bbox="618 1327 1027 1362">01/01/2015- 31/12/2015</td> <td data-bbox="1027 1327 1333 1362">91,038.21</td> </tr> <tr> <td data-bbox="618 1362 1027 1415">Total</td> <td data-bbox="1027 1362 1333 1415">332,899.25</td> </tr> </tbody> </table>	Period	EG _{output,y} (MWh)	24/04/2012 - 31/12/2012	63,380.31	01/01/2013- 31/12/2013	87,622.61	01/01/2014- 31/12/2014	90,858.12	01/01/2015- 31/12/2015	91,038.21	Total	332,899.25
Period	EG _{output,y} (MWh)												
24/04/2012 - 31/12/2012	63,380.31												
01/01/2013- 31/12/2013	87,622.61												
01/01/2014- 31/12/2014	90,858.12												
01/01/2015- 31/12/2015	91,038.21												
Total	332,899.25												
Monitoring equipment	Electricity meter reading (M1, M3, M4 and M5) at the on-site substation. Please refer to the monitoring equipment information in the table of parameters.												
QA/QC procedures to be applied	The meters M3 and M4 at the project site and meters M1 and M5 are calibrated once a year according to the national rules of Relative Technical Administrative Code of Electric Energy Metering. Electricity supplied to the grid is double checked against electricity sales receipts. Meter readings from meters M1 ($EG_{\text{output},y}$) and M5 ($EG_{B,y}$) also are used for cross checking. Conservative values are adopted for ERs calculation.												
Purpose of the data	Baseline Emission calculation												
Calculation method	The following equation will be applied:												

	$EG_{\text{export},y} = EG_{A,y} / (EG_{A,y} + EG_{B,y}) * EG_{\text{output},y}$ <p>Where:</p> <p>$EG_{\text{export},y}$ = Electricity exported by the project activity to the grid in year y</p> <p>$EG_{\text{output},y}$ = Total electricity supplied to the grid by the proposed project and Project B in the year y, which is measured by the main meter M1.</p> <p>$EG_{A,y}$ = Electricity supplied to the grid by the proposed project in the year y, which is measured by the meters M3 and M4.</p> <p>$EG_{B,y}$ = Electricity supplied to the grid by the Project B in the year y, which is measured by the meter M5.</p>
Comments	-

Data / Parameter	$EG_{\text{import},y}$												
Data unit	MWh												
Description	Electricity delivered to the project by the grid in year y.												
Source of data	The readings of the meter M1 at the connection point between the proposed project and the Grid												
Description of measurement methods and procedures to be applied	<p>M1 as the main meter at Muling 220kV substation (M2 as the back-up meter in the wind farm) which use to monitor the total electricity delivered to the grid by the proposed project and another project (Shandong Tangwangshan Wind Farm Project, hereafter referred to Project B).</p> <p>Meter readings from M1 will be used for cross checking with the electricity sales receipts issued by the grid company.</p>												
Frequency of monitoring/recording	Continuously measurement and monthly recording												
Value monitored	<table border="1"> <thead> <tr> <th>Period</th> <th>$EG_{\text{input},y}$ (MWh)</th> </tr> </thead> <tbody> <tr> <td>24/04/2012 - 31/12/2012</td> <td>236.7200</td> </tr> <tr> <td>01/01/2013- 31/12/2013</td> <td>513.9200</td> </tr> <tr> <td>01/01/2014- 31/12/2014</td> <td>726.8800</td> </tr> <tr> <td>01/01/2015- 31/12/2015</td> <td>806.9600</td> </tr> <tr> <td>Total</td> <td>2,284.48</td> </tr> </tbody> </table>	Period	$EG_{\text{input},y}$ (MWh)	24/04/2012 - 31/12/2012	236.7200	01/01/2013- 31/12/2013	513.9200	01/01/2014- 31/12/2014	726.8800	01/01/2015- 31/12/2015	806.9600	Total	2,284.48
Period	$EG_{\text{input},y}$ (MWh)												
24/04/2012 - 31/12/2012	236.7200												
01/01/2013- 31/12/2013	513.9200												
01/01/2014- 31/12/2014	726.8800												
01/01/2015- 31/12/2015	806.9600												
Total	2,284.48												
Monitoring equipment	Electricity meter reading (M1) at the on-site substation. Please refer to the monitoring equipment information in the table of parameters.												
QA/QC procedures to be applied	The meter M1 will be calibrated once a year according to the national rules. Meter readings from the meter M1 will be directly applied for												

	cross checking of electricity purchased from the grid by the proposed project. Electricity purchased from the grid will be double checked against electricity sales receipts. Conservative values will be adopted for ERs calculation. Data will be archived for 2 years following the end of the last crediting period.
Purpose of the data	Baseline Emission calculation
Calculation method	-
Comments	-

monitoring equipment information

Meters	Serial No.	Accuracy	Calibration date	Calibration frequency	Validity
M1	1305712953	0.5S	13/01/2012	Annually	Yes
M2	09070125900004	0.2S		13/01/2013	Annually
M3	09090151400332	0.5S	13/01/2014		Annually
M4	09090151400334	0.5S		13/01/2015	Annually
M5	09090151400336	0.5S			Annually

4.3 Monitoring Plan

The 58 sets of wind turbines of the project are connected with two 35kV transmission lines. Two electricity meters (M3 and M4) are installed on the 35kV transmission lines at the project site. The M3 and M4 are used to measure the electricity supplied to the grid and electricity imported from the grid by the project, which are equal to the summation of the readings of M3 and M4. The accuracies of the two meters are no lower than 0.5s, and the calibration frequency is once a year in line with the national rules of Relative Technical Administrative Code of Electric Energy Metering.

Since the project is sharing the meter M1 (with M2 as backup meter) at Muling 220kV substation, meter M1 at the Muling 220kV substation measures the electricity exchange between the proposed project and another project (Shandong Yishui Tangwangshan Wind Farm project, hereafter referred to Project B). Electricity exchange between Project B and the grid is measured by meter M5 installed at the project site. The accuracies of the two meters M1 and M5 are no lower than 0.5s, and the calibration frequency is once a year in line with the national rules of Relative Technical Administrative Code of Electric Energy Metering. Also, sales receipts for the proposed CDM project activity will be used for double checking following the requirement in the applied methodology.

For cross checking of the electricity exported by the proposed project against meter readings from M1 and M5, the following equation will be applied.

$$EG_{\text{export},y} = EG_{A,y} / (EG_{A,y} + EG_{B,y}) * EG_{\text{output},y}$$

Where:

$EG_{\text{export},y}$ = Electricity exported by the project activity to the grid in year y

$EG_{\text{output},y}$ = Total electricity supplied to the grid by the proposed project and Project B in the year y, which is measured by the main meter M1.

$EG_{A,y}$ = Electricity supplied to the grid by the proposed project in the year y, which is measured by the meters M3 and M4.

$EG_{B,y}$ = Electricity supplied to the grid by the Project B in the year y, which is measured by the meter M5.

Meter readings from meter M1 which measures the electricity imported by both the proposed CDM project and project B will be directly applied for cross checking of electricity imported from the grid by the proposed CDM project activity.

The simplified wiring diagram is showed as below:

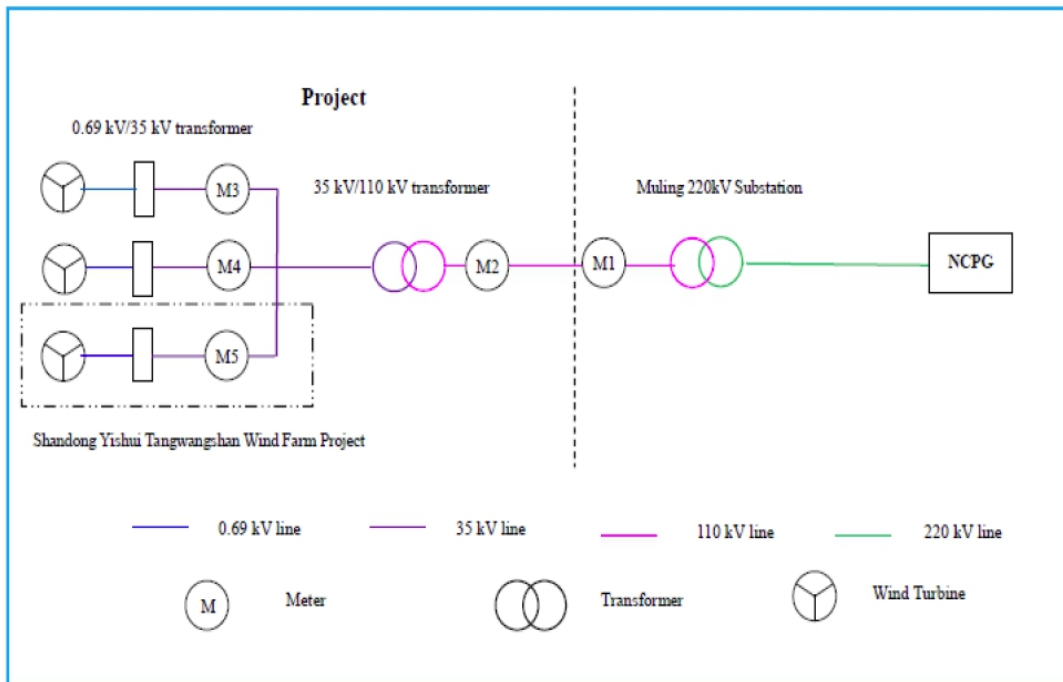

Monitoring organizational structure, roles and responsibilities

The project owner will use this document as guideline in monitoring of the project emission reduction performance and will adhere to the guidelines set out in this monitoring plan to ensure that the monitoring is credible, transparent and conservative.

The responsibilities of the project staff are as follows:

General Manager: To be responsible for supervising the whole monitoring procedure.

CDM Project Manager: To be responsible for data management and compiling monitoring report.

Operational and monitoring manager: To be responsible for collecting data and do internal audit.

Financial chief: To be responsible for collection of sales receipts.

Technical chief: To be responsible for preparing operational reports of the project activity, recording the daily operation of the wind farm, including operating periods, equipment defects, etc.

The organization of the monitoring implementers is illustrated in the table below:

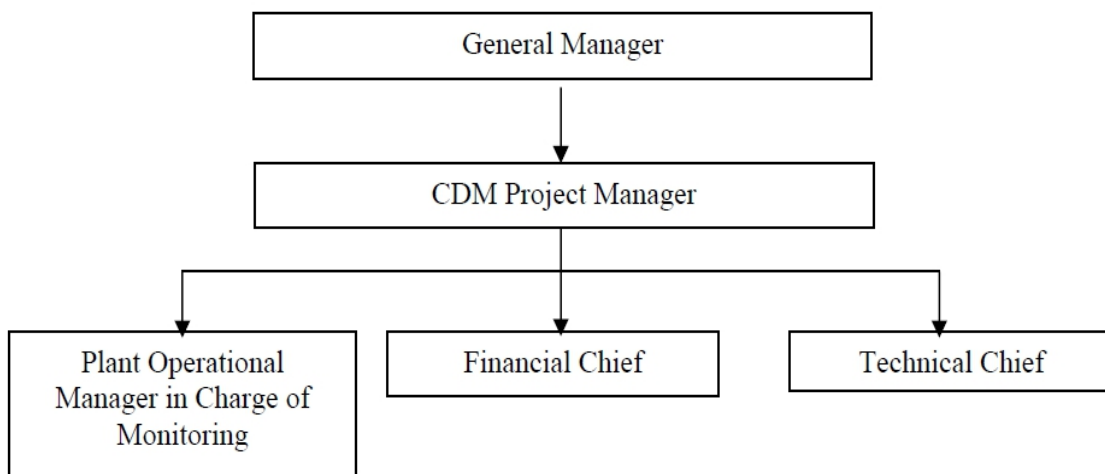

Data Management System

To keep safely the record of the data collected during monitoring, this project will set up a complete data management system. The project will perfect the whole monitoring procedure by developing the CDM manual, tracking information from the primary source to the end-data calculations in paper document format. It is the responsibility of the proposed project owner to provide additional necessary data and information for validation and verification requirements of respective DOE. Physical documentation such as paper-based maps, diagrams and environmental assessment will be collated in a central place, together with this monitoring plan. All paper-based information will be stored by the proposed project owner and kept at least one copy.

At the end of each month, the monitoring data will be filed in a spreadsheet, and the paper-based printout will be also archived as well. Furthermore, the project owner collects the sales receipts for the electricity supplied to the grid as a cross-check, and compiled the monitoring report including the monitoring data and relevant evidence at the end of each crediting year.

All the data will be kept for two years following the end of the last crediting period.

Quality Assurance and Quality Control

The workers are trained to be competent and the metering equipments are calibrated and sealed as per the industry practices at regular intervals, with the purpose to provide credible, accurate, transparent and conservative monitoring data and ensure the real, measurable, long-term GHG emission reduction from this project.

Monthly metering data of the supplied and purchased electricity by the proposed project will be approved and signed off by the Manager before it is accepted and stored. This audit will check compliance with monitoring procedures in this monitoring plan. This internal audit will also identify potential improvements to procedures to improve monitoring and reporting in future years. The monitoring officers will also attend a training session organized by the CDM consultant. The purpose of training is to assure those staffs are competent to conduct the monitoring plan, thus to make the monitored data accurate.

5 QUANTIFICATION OF GHG EMISSION REDUCTIONS AND REMOVALS

5.1 Baseline Emissions

Baseline Emissions are calculated by multiplying the ex-ante Baseline Emission factor by annual power generation.

$$BE_y = EG_{\text{Facility},y} \times EF_{\text{grid},\text{CM},y}$$

Where:

BE_y = Baseline emissions in year y (tCO₂/yr)

$EG_{\text{Facility},y}$ = Quantity of net electricity generation supplied to the grid by the Project in year y. (MWh)

$EF_{\text{grid},\text{CM},y}$ = Combined margin emission factor for grid connected power generation in year y (tCO₂/MWh).

$$EG_{\text{facility},y} = EG_{\text{export},y} - EG_{\text{import},y} = EG_{\text{A},y} / (EG_{\text{A},y} + EG_{\text{B},y}) * EG_{\text{output},y} - EG_{\text{import},y}$$

Where:

- $EG_{\text{facility},y}$ = Quantity of net electricity generation supplied by the project plant/unit to the grid in year y (in MWh);

- $EG_{\text{export},y}$ = Electricity exported by the project activity to the grid in year y

$EG_{\text{output},y}$ = Total electricity supplied to the grid by the proposed project and Project B in the year y , which is measured by the main meter M1.

$EG_{A,y}$ = Electricity supplied to the grid by the proposed project in the year y , which is measured by the meters M3 and M4.

$EG_{B,y}$ = Electricity supplied to the grid by the Project B in the year y , which is measured by the meter M5.

$EG_{\text{import},y}$ = Electricity imported by the project activity to the grid in year y

Table 1: the electricity generation of the proposed project ($EG_{\text{export},y}$)

Period	Electricity generation of the proposed project and the other project by the meters						
	$EG_{B,y}$ by the meter M5	$EG_{A,y}$ by the meter M3	$EG_{A,y}$ by the meter M4	$EG_{\text{output},y}$ by the meter M1	$EG_{\text{export},y}$		
	B	A1	A2	C	MRR $D=(A1+A2)/(A1+A2+B)*C$	ETN (E)	Value ($F=\text{Min}(D,E)$)
24/04/2012-24/04/2012	373.24	375.48	655.76	1369.94	1005.88	14705.12	1005.88
25/04/2012-24/05/2012	2614.92	4364.36	4364.92	11235.84	8645.90	8645.90	8645.90
25/05/2012-24/06/2012	2718.52	5081.44	5049.80	12731.84	10038.27	10038.27	10038.27
25/06/2012-24/07/2012	2306.92	3414.60	3405.92	9029.68	6747.47	6747.47	6747.47
25/07/2012-24/08/2012	1803.76	2834.02	2834.02	7398.16	5612.18	5612.18	5612.18
25/08/2012-24/09/2012	2191.00	3225.18	3226.86	8566.80	6395.13	6395.13	6395.13
25/09/2012-24/10/2012	3084.48	4685.24	4684.12	12359.60	9298.46	9298.46	9298.46
25/10/2012-24/11/2012	3229.52	4437.58	4433.10	12010.24	8804.73	8804.73	8804.73
25/11/2012-24/12/2012	2772.84	2746.52	2748.20	8199.84	5449.71	5449.71	5449.71
25/12/2012-31/12/2012	603.68	695.66	697.34	1981.76	1382.59	1382.59	1382.59
Subtotal 2012							63380.31
01/01/2013-31/01/2013	2308.32	2405.06	2401.14	7033.84	4751.70	4751.70	4751.70
01/02/2013-28/02/2013	3267.88	3377.22	3354.26	9890.32	6658.08	6658.08	6658.08
01/03/2013-31/03/2013	3360.84	3015.18	3010.98	9299.84	5970.21	5970.21	5970.21
01/04/2013-30/04/2013	4752.72	3910.20	3909.92	12453.76	7746.05	7746.05	7746.05
01/05/2013-31/05/2013	3832.92	2755.20	2747.36	9236.48	5444.21	5444.21	5444.21
01/06/2013-30/06/2013	3268.72	2864.26	2855.86	8908.24	5668.83	5668.83	5668.83
01/07/2013-31/07/2013	2800.84	4679.50	4676.70	12066.56	9286.57	9286.57	9286.57
01/08/2013-31/08/2013	2716.84	3281.46	3284.82	9200.40	6507.77	6507.77	6507.77
01/09/2013-30/09/2013	1397.48	3677.38	3677.38	8689.12	7301.72	7301.72	7301.72
01/10/2013-31/10/2013	3759.84	5578.58	5574.10	14824.48	11086.84	11086.84	11086.84

01/11/2013-30/11/2013	2850.12	4155.76	4151.28	11068.64	8241.13	8241.13	8241.13
01/12/2013-31/12/2013	3382.68	4515.00	4510.80	12317.36	8959.52	8959.52	8959.52
Subtotal 2013							87622.61
01/01/2014-31/01/2014	2878.68	3951.36	3947.16	10686.72	7832.21	7832.21	7832.21
01/02/2014-28/02/2014	3851.96	5416.60	5413.80	14587.76	10760.62	10760.62	10760.62
01/03/2014-31/03/2014	6983.48	5544.42	5536.58	17935.28	11001.75	11001.75	11001.75
01/04/2014-30/04/2014	1835.68	2896.32	2893.52	7569.76	5747.50	5747.50	5747.50
01/05/2014-31/05/2014	6064.52	5142.20	5137.44	16247.44	10218.81	10218.81	10218.81
01/06/2014-30/06/2014	2738.96	4070.92	4074.28	10786.16	8071.86	8071.86	8071.86
01/07/2014-31/07/2014	1867.32	2932.86	2933.14	7659.52	5810.02	5810.02	5810.02
01/08/2014-31/08/2014	1259.72	1497.02	1500.10	4214.32	2967.18	2967.18	2967.18
01/09/2014-30/09/2014	836.92	1459.92	1459.08	3720.64	2891.58	2891.58	2891.58
01/10/2014-31/10/2014	3311.00	4148.34	4152.82	11492.80	8215.83	8215.83	8215.83
01/11/2014-30/11/2014	2724.12	3548.72	3544.24	9726.64	7027.62	7027.62	7027.62
01/12/2014-31/12/2014	3750.60	5192.04	5188.12	14039.52	10313.14	10313.14	10313.14
Subtotal 2014							90858.12
01/01/2015-31/01/2015	3192.56	4438.98	4438.98	11978.56	8810.32	8810.32	8810.32
01/02/2015-28/02/2015	2932.44	3596.32	3591.84	10027.60	7122.11	7122.11	7122.11
01/03/2015-31/03/2015	5336.24	5061.28	5056.80	15363.92	10058.89	10058.89	10058.89
01/04/2015-30/04/2015	6027.56	6065.78	6062.98	18047.04	12055.76	12055.76	12055.76
01/05/2015-31/05/2015	3411.24	4935.42	4930.66	13180.64	9794.24	9794.24	9794.24
01/06/2015-30/06/2015	2816.52	4325.86	4324.74	11366.96	8575.04	8575.04	8575.04
01/07/2015-31/07/2015	910.56	1740.76	1743.56	4363.04	3459.08	3459.08	3459.08
01/08/2015-31/08/2015	1680.84	2567.74	2564.94	6750.48	5085.19	5085.19	5085.19
01/09/2015-30/09/2015	1182.72	1617.42	1613.22	4377.12	3204.11	3204.11	3204.11
01/10/2015-31/10/2015	2226.00	3265.36	3260.88	8663.60	6460.14	6460.14	6460.14
01/11/2015-30/11/2015	3767.68	4259.50	4260.06	12200.32	8459.29	8459.29	8459.29
01/12/2015-31/12/2015	2843.12	4016.32	4008.48	10772.08	7954.03	7954.03	7954.03
Subtotal 2015							91038.21
Total							332,899.25

Table 2: Calculation of net electricity supplied to the grid

Period	EG _{importy}		
	MRR	ETN	Value
	G	H	I=Max(G,H)
24/04/2012-24/04/2012	-	-	-
25/04/2012-24/05/2012	32.56	32.56	32.56

25/05/2012-24/06/2012	29.04	29.04	29.04
25/06/2012-24/07/2012	31.68	31.68	31.68
25/07/2012-24/08/2012	28.16	28.16	28.16
25/08/2012-24/09/2012	30.80	30.80	30.80
25/09/2012-24/10/2012	22.88	22.88	22.88
25/10/2012-24/11/2012	22.00	22.00	22.00
25/11/2012-24/12/2012	30.80	30.80	30.80
25/12/2012-31/12/2012	8.80	8.80	8.80
Subtotal 2012			236.72
01/01/2013-31/01/2013	25.52	25.52	25.52
01/02/2013-28/02/2013	34.32	34.32	34.32
01/03/2013-31/03/2013	39.60	39.60	39.60
01/04/2013-30/04/2013	41.36	41.36	41.36
01/05/2013-31/05/2013	51.04	51.04	51.04
01/06/2013-30/06/2013	58.08	58.08	58.08
01/07/2013-31/07/2013	44.00	44.00	44.00
01/08/2013-31/08/2013	42.24	42.24	42.24
01/09/2013-30/09/2013	48.40	48.40	48.40
01/10/2013-31/10/2013	43.12	43.12	43.12
01/11/2013-30/11/2013	41.36	41.36	41.36
01/12/2013-31/12/2013	44.88	44.88	44.88
Subtotal 2013			513.92
01/01/2014-31/01/2014	58.08	58.08	58.08
01/02/2014-28/02/2014	66.88	66.88	66.88
01/03/2014-31/03/2014	63.36	63.36	63.36
01/04/2014-30/04/2014	66.00	66.00	66.00
01/05/2014-31/05/2014	51.92	51.92	51.92
01/06/2014-30/06/2014	50.16	50.16	50.16
01/07/2014-31/07/2014	64.24	64.24	64.24
01/08/2014-31/08/2014	59.84	59.84	59.84
01/09/2014-30/09/2014	68.64	68.64	68.64
01/10/2014-31/10/2014	51.92	51.92	51.92
01/11/2014-30/11/2014	58.96	58.96	58.96
01/12/2014-31/12/2014	66.88	66.88	66.88
Subtotal 2014			726.88
01/01/2015-31/01/2015	66.88	66.88	66.88
01/02/2015-28/02/2015	63.36	63.36	63.36
01/03/2015-31/03/2015	66.00	66.00	66.00
01/04/2015-30/04/2015	51.92	51.92	51.92
01/05/2015-31/05/2015	76.56	76.56	76.56
01/06/2015-30/06/2015	64.24	64.24	64.24
01/07/2015-31/07/2015	59.84	59.84	59.84
01/08/2015-31/08/2015	68.64	68.64	68.64
01/09/2015-30/09/2015	69.52	69.52	69.52
01/10/2015-31/10/2015	73.92	73.92	73.92
01/11/2015-30/11/2015	69.52	69.52	69.52
01/12/2015-31/12/2015	76.56	76.56	76.56
Subtotal 2015			806.96

Total			2,284.48
-------	--	--	----------

Table 3: Calculation of baseline emission reductions

Period	EG _{export,y}	EG _{import,y}	EG _{facility,y}	EF _{grid,CM,y}	BE _y
	(MWh)	(MWh)	(MWh)	(tCO _{2e} /MWh)	(tCO _{2e})
24/04/2012 - 31/12/2012	63,380.31	236.7200	63,143.59	0.9309	58,780
01/01/2013- 31/12/2013	87,622.61	513.9200	87,108.69	0.9309	81,089
01/01/2014- 31/12/2014	90,858.12	726.8800	90,131.24	0.9309	83,903
01/01/2015- 31/12/2015	91,038.21	806.9600	90,231.25	0.9309	83,996
Total	332,899.25	2,284.48	330,614.77		307,768

5.2 Project Emissions

According to ACM0002 (Version 12.2.0), no project emissions were to be counted by the Project.

Hence, PE_y=0 tCO_{2e}.

5.3 Leakage

According to the baseline methodology ACM0002 (version 12.2.0), the leakage of the Project is not considered.

5.4 Net GHG Emission Reductions and Removals

Year	Baseline emissions or removals (tCO _{2e})	Project emissions or removals (tCO _{2e})	Leakage emissions (tCO _{2e})	Net GHG emission reductions or removals (tCO _{2e})
Year 2012 (24/04/2012 - 31/12/2012)	58,780	0	0	58,780
Year 2013	81,089	0	0	81,089
Year 2014	83,903	0	0	83,903
Year 2015	83,996	0	0	83,996
Total	307,768	0	0	307,768

The annual average emission reductions estimated in the registered PD is 84,740 tCO₂, so the estimated amount of emission reductions for the corresponding 1,347 days (the duration of

this monitoring period) are $1,347/365 \times 84,740 = 312,725 \text{tCO}_2$, which is higher than the actual value of 307,768 tCO₂.