

# VIÑALES BIOMASS POWER PLANT



Document Prepared By: Arauco Bioenergía S.A.

## Contact Information (optional):

|                      |  |
|----------------------|--|
| <b>Project Title</b> | <i>Viñales biomass power plant</i>   |
| <b>Version</b>       | 03   |
| <b>Date of Issue</b> | 31-05-2016   |
| <b>Prepared By</b>   | <i>Arauco Bioenergía S.A.</i>  |
| <b>Contact</b>       | <i>Christian A. Patrickson, Av. El Golf 150, 7<sup>th</sup> floor, Las Condes, Santiago, Chile, South America. Phone: 56 2 24623795, cpatrickson@arauco.cl, www.arauco.cl.</i> |

## Table of Contents

|        |   |     |
|--------|---|-----|
| 1      | Project Details .....   | 3   |
| 1.1    | Summary Description of the Project .....                              | 3   |
| 1.2    | Sectoral Scope and Project Type.....                                  | 3   |
| 1.3    | Project Proponent .....   | 4   |
| 1.4    | Other Entities Involved in the Project.....                           | 4   |
| 1.5    | Project Start Date.....   | 4   |
| 1.6    | Project Crediting Period .....  | 4   |
| 1.7    | Project Scale and Estimated GHG Emission Reductions or Removals ..... | 4   |
| 1.8    | Description of the Project Activity.....                              | 5   |
| 1.9    | Project Location .....  | 8   |
| 1.10   | Conditions Prior to Project Initiation .....                          | 8   |
| 1.11   | Compliance with Laws, Statutes and Other Regulatory Frameworks.....   | 9   |
| 1.12   | Ownership and Other Programs .....                                    | 9   |
| 1.12.1 | Right of Use.....   | 9   |
| 1.12.2 | Emissions Trading Programs and Other Binding Limits .....             | 9   |
| 1.12.3 | Participation under Other GHG Programs .....                          | 9   |
| 1.12.4 | Other Forms of Environmental Credit .....                             | 9   |
| 1.12.5 | Projects Rejected by Other GHG Programs .....                         | 9   |
| 1.13   | Additional Information Relevant to the Project.....                   | 10  |
| 2      | Application of Methodology .....                                      | 10  |
| 2.1    | Title and Reference of Methodology .....                              | 10  |
| 2.2    | Applicability of Methodology.....                                     | 11  |
| 2.3    | Project Boundary.....   | 12  |
| 2.4    | Baseline Scenario .....   | 16  |
| 2.5    | Additionality.....  | 48  |
| 2.6    | Methodology Deviations .....  | 50  |
| 3      | Quantification of GHG Emission Reductions and Removals .....          | 51  |
| 3.1    | Baseline Emissions .....  | 51  |
| 3.2    | Project Emissions.....  | 60  |
| 3.3    | Leakage.....  | 64  |
| 3.4    | Summary of GHG Emission Reductions and Removals.....                  | 65  |
| 4      | Monitoring.....   | 65  |
| 4.1    | Data and Parameters Available at Validation .....                     | 65  |
| 4.2    | Data and Parameters Monitored.....                                    | 71  |
| 4.3    | Description of the Monitoring Plan .....                              | 108 |
| 5      | Environmental Impact.....   | 109 |
| 6      | Stakeholder Comments.....   | 110 |
|        | ANNEX 1.....  | 111 |
|        | ANNEX 2.....  | 116 |
|        | ANNEX 3.....  | 122 |
|        | ANNEX 4.....  | 129 |

## 1 PROJECT DETAILS

### 1.1 Summary Description of the Project

The proposed project activity consists in the installation of a new biomass cogeneration power plant in the Viñales sawmill site. The new cogeneration plant is equipped with a new 210 ton/hr fluidized bed biomass power boiler and a 41 MW condensing/extracting turbo generator unit.

The project activity is designed to use biomass from industrial operations (sawdust and bark, mainly from sawmills) and biomass from forestry operations (from harvesting, thinning and pruning operations) for electric power generation. In the absence of the project activity, such biomass would be burned uncontrollably in the open air or left in piles to natural decay.

The project is presented by Celulosa Arauco y Constitución S.A. (from now on, Arauco), a leading forestry and pulp-producing company in Chile.

Before the implementation of the project activity, the Viñales sawmill relied on an external company, who supplied heat for wood drying, and on the grid for electric power. The proposed project activity is designed –then- to integrate the new cogeneration power plant to the Viñales sawmill, in order to cogenerate heat and power for this facility and to export the surplus power to the grid.

When the Arauco management evaluated the Viñales biomass power plant project, it considered the surplus of biomass available in the region and decided to install a new big-scale cogeneration unit that allowed cogenerating heat and power instead of installing a traditional low pressure boiler in the Viñales site which would allow only generating saturated steam. This alternative implied going beyond the common practice of the Sawmill industry in Chile, which does not contemplate the use of the cogeneration technology in this type of facility. Given that this more sophisticated alternative implied higher investment and operation costs than the conventional alternative, the decision of installing electric power generating capacity in the Viñales sawmill relied on the possibility of not depending on the local grid for electric power consumption anymore, the possibility of selling surplus power to the grid and on the benefits derived from carbon proceeds.

The proposed project activity assists Chile's sustainable growth by providing electricity to the Viñales sawmill and to the local grid through renewable biomass power generation. Without the Viñales project activity, not only there would be no new clean energy injection to the local grid, but the Viñales sawmill would continue sourcing its electric power requirements from the grid. In addition, this project accomplishes an additional greenhouse (GHG) reduction benefit derived from a reduced disposal or uncontrolled burning of biomass residues, which results in lower methane emissions to the atmosphere.

The Viñales biomass power plant project activity participants believe that biomass power generation constitutes a sustainable source of power generation that brings clear advantages to mitigate Global Warming. Using the available natural resources in a rational way, the Viñales project activity helps to enhance the development of renewable energy sources in Chile, in particular the use of biomass generated as a by-product of the forestry industry, which has a significant potential in the country. The proposed project is a good example to demonstrate the viability of electricity generation as a source of revenue not only to the Sawmill industry, but also, to all forest-related industries. It is worthy to highlight that very few sawmills in Chile have on-site electric power generation capacity, making the Viñales biomass power plant project activity quite unique and particular in its type.

### 1.2 Sectoral Scope and Project Type

The Viñales biomass power plant is a renewable energy supply side grid-connected project activity. It involves reduction of emission of greenhouse gases in the energy sector; more specifically, reduction of

greenhouse gas emission sources from fuel combustion in energy industries, according to the list of sector/source categories indicated in Annex A of the Kyoto Protocol. The Viñales project activity is not a grouped project activity.

### 1.3 Project Proponent

The project is presented by Celulosa Arauco y Constitución S.A., a leading Forestry and Pulp-producing company in Chile. However, the project owner and administrator is Aserraderos Arauco S.A., the sawmill division of Celulosa Arauco S.A.

In both cases, the commercial address is Av. El Golf, 150, 14<sup>th</sup> floor. The phone number is 56 2 24617200.

### 1.4 Other Entities Involved in the Project

There are no other entities involved in the proposed project activity.

### 1.5 Project Start Date

19/05/2012

This is the date in which the Viñales power plant started generating electric power.

### 1.6 Project Crediting Period

The project crediting period start date is 01/01/2014. The first crediting period will last for 10 years and will be renewed 2 times, adding up to 30 years in total (3 x 10 years).

### 1.7 Project Scale and Estimated GHG Emission Reductions or Removals

|               |   |
|---------------|---|
| Project       | X |
| Large project |   |

| Years | Estimated GHG emission reductions or removals (tCO <sub>2</sub> e) |
|-------|--|
| 2014  | 258,093  |
| 2015  | 258,093  |
| 2016  | 258,093  |
| 2017  | 258,093  |
| 2018  | 258,093  |
| 2019  | 258,093  |

|  |           |
|--|-----------|
| 2020                                   | 258,093   |
| 2021                                   | 258,093   |
| 2022                                   | 258,093   |
| 2023                                   | 258,093   |
| <b>Total estimated ERs</b>             | 2,580,929 |
| <b>Total number of crediting years</b> | 10        |
| <b>Average annual ERs</b>              | 258,093   |

### 1.8 Description of the Project Activity

The Viñales power plant consists of a biomass fluidized-bed boiler of 210 ton/hr of high pressure steam capacity and a 41 MW condensing-extracting turbo generator machine. The plant uses the Rankine cycle to cogenerate heat (steam) and electric power in the Viñales sawmill site. The heat is used in the Viñales sawmill for wood-drying while a fraction of the electric power is also used in the Viñales sawmill. The remaining electric power is injected in the SIC grid for sale.

The predominant technology in all parts of the world today for generating megawatt (MW) levels of electricity from biomass is the steam-Rankine cycle, which consists of direct combustion of biomass in a boiler to generate steam, which is then expanded through a turbine. The steam-Rankine technology is a mature technology, having been introduced into commercial use about 100 years ago. Most steam cycle plants are located at industrial sites, where the waste heat from the steam turbine is recovered and used for meeting industrial-process heat needs. Such combined heat and power (CHP), or cogeneration systems provide greater levels of energy services per unit of biomass consumed than systems that generate electric power only.

The steam-Rankine cycle involves heating pressurized water, with the resulting steam expanding to drive a turbine-generator, and then condensing back to water for partial or full recycling to the boiler. A heat exchanger is used in some cases to recover heat from flue gases to preheat combustion air, and a deaerator must be used to remove dissolved oxygen from water before it enters the boiler.

Steam turbines are designed as either “backpressure” or “condensing” turbines. CHP applications typically employ backpressure turbines, wherein steam expands to a pressure that is still substantially above ambient pressure. It leaves the turbine still as a vapor and is sent to satisfy industrial heating needs, where it condenses back to water. It is then partially or fully returned to the boiler. Alternatively, if process steam demands can be met using only a portion of the available steam, a condensing extraction steam turbine (CEST) might be used. This design includes the capability for some steam to be extracted at one or more points along the expansion path for meeting process needs (figure 3). Steam that is not extracted continues to expand to sub-atmospheric pressures, thereby increasing the amount of electricity generated per unit of steam compared to the backpressure turbine. The non-extracted steam is converted back to liquid water in a condenser that utilizes ambient air and/or a cold water source as the coolant.

**Diagram of a steam-Rankine cycle for cogeneration using a condensing-extracting steam turbine.**

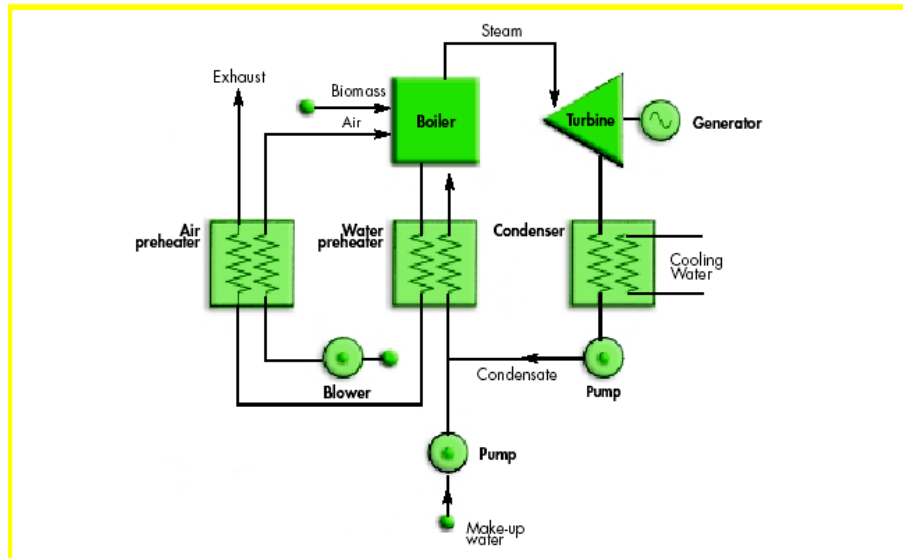

Source: Williams & Larson, 1993 apud Kartha & Larson, 2000, p. 101.

Though the baseline or reference project alternative will be explained in detail in subsequent sections of this document, the most likely project alternative that would have been implemented instead of the proposed project activity would have been the installation of a new low-pressure biomass boiler that would have generated heat (no cogeneration) for the Viñales sawmill. The following table and energy/mass balances provide a general description of how the baseline project would have differed from the proposed project activity:

| Department                | Changes   |
|---------------------------|---|
| Biomass Boiler            | <ul style="list-style-type: none"> <li>Instead of the 210 ton/hr, 85 bar superheated steam biomass power boiler, there would have been a 75 (ton/hr), 20 bar, saturated steam biomass boiler.</li> </ul>  |
| Steam Distribution System | <ul style="list-style-type: none"> <li>Under a conventional scenario, the steam pressure of the new boiler unit would have been substantially lower, so the steam distribution system would have been simpler and less expensive compared to the one under the project scenario.</li> </ul> |
| Process equipment         | <ul style="list-style-type: none"> <li>There would have been fewer and less expensive equipment. For example, the biomass fuel processing/management equipment would have been designed for a smaller capacity.</li> </ul>  |
| Turbogenerator            | <ul style="list-style-type: none"> <li>There would have been no extracting/condensing turbogenerator.</li> </ul>  |
| Electrical Equipment      | <ul style="list-style-type: none"> <li>Without the new power generation capacity, there would have been no new electrical equipment needed; there would have been no generator and the corresponding power distribution equipment would have not been required.</li> </ul>                  |

The following diagrams show the power generation situation under a BAU (Business-As-Usual) situation, without investment in additional power generation capacity; and under the project situation, with additional investment in additional power generation capacity.

**The Viñales project without power cogeneration**

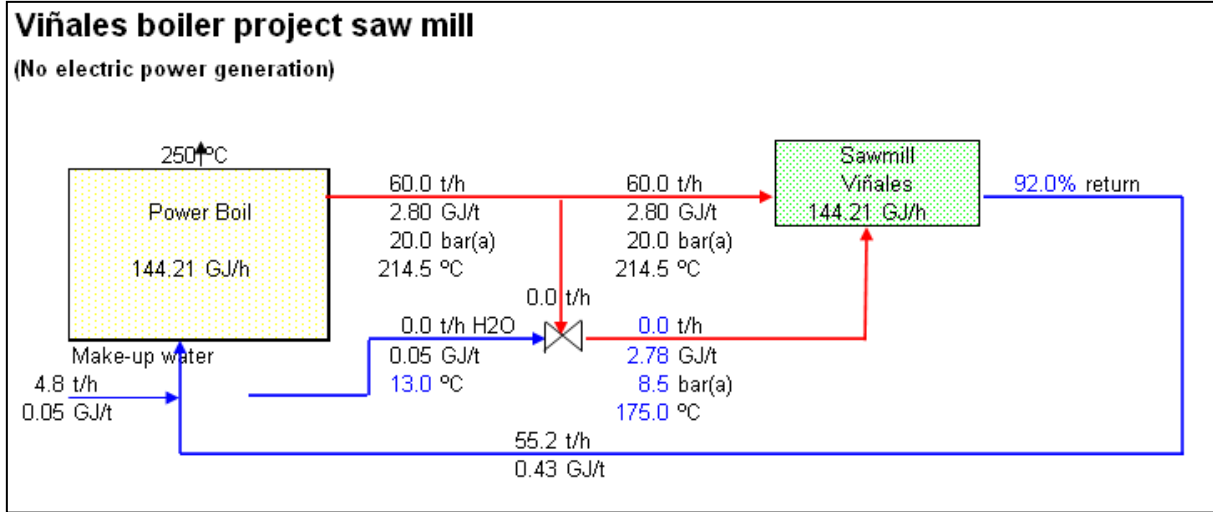

**The Viñales project with power generation capacity (cogeneration)**

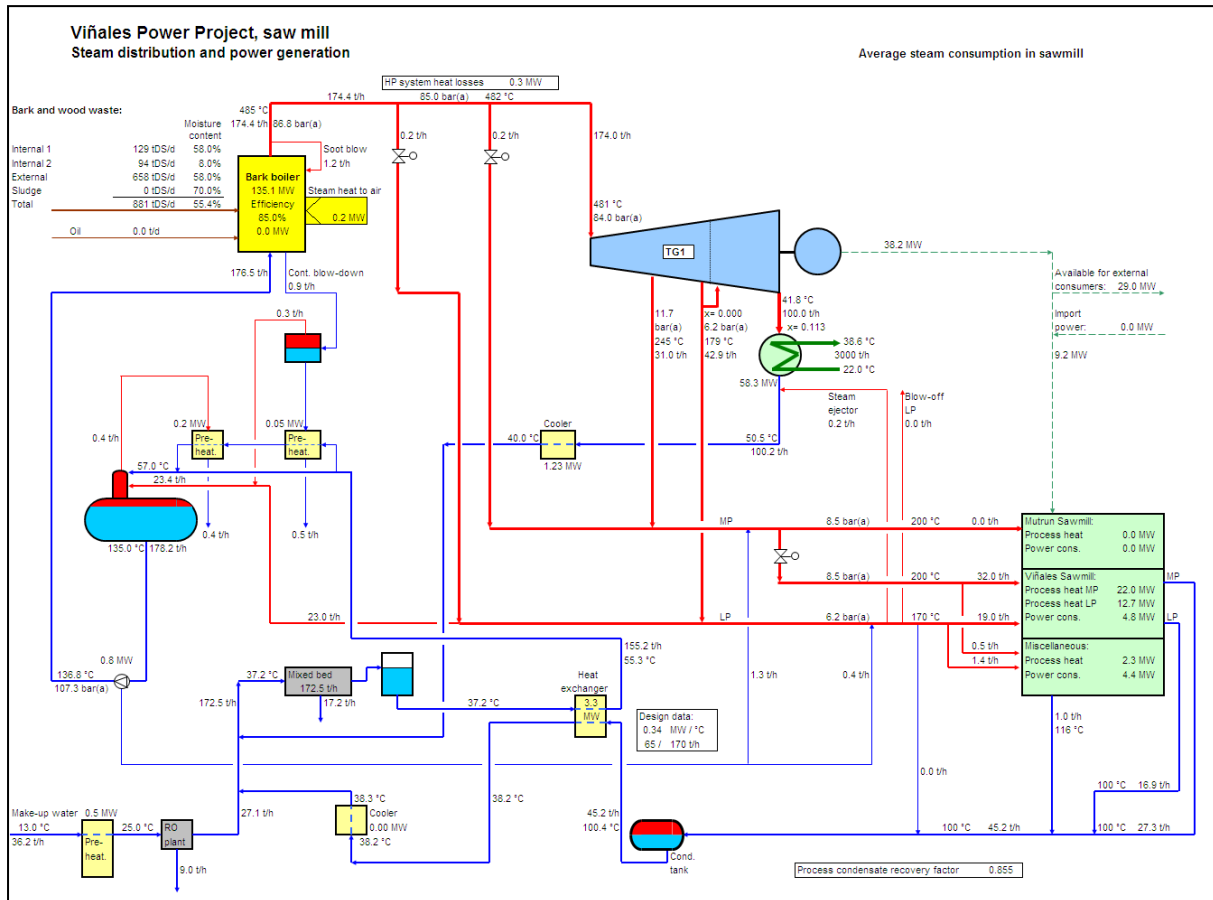

### 1.9 Project Location

The project activity is located in Km. 5 of the M-50 road to Chanco, commune of Constitución in the Maule Region. The nearest city is Constitución, located 3 Km away from the new power plant.

The project activity coordinates in decimals are provided in the table below:

|          |           |
|----------|-----------|
| Latitude | Longitude |
| -35.371° | -72.412°  |

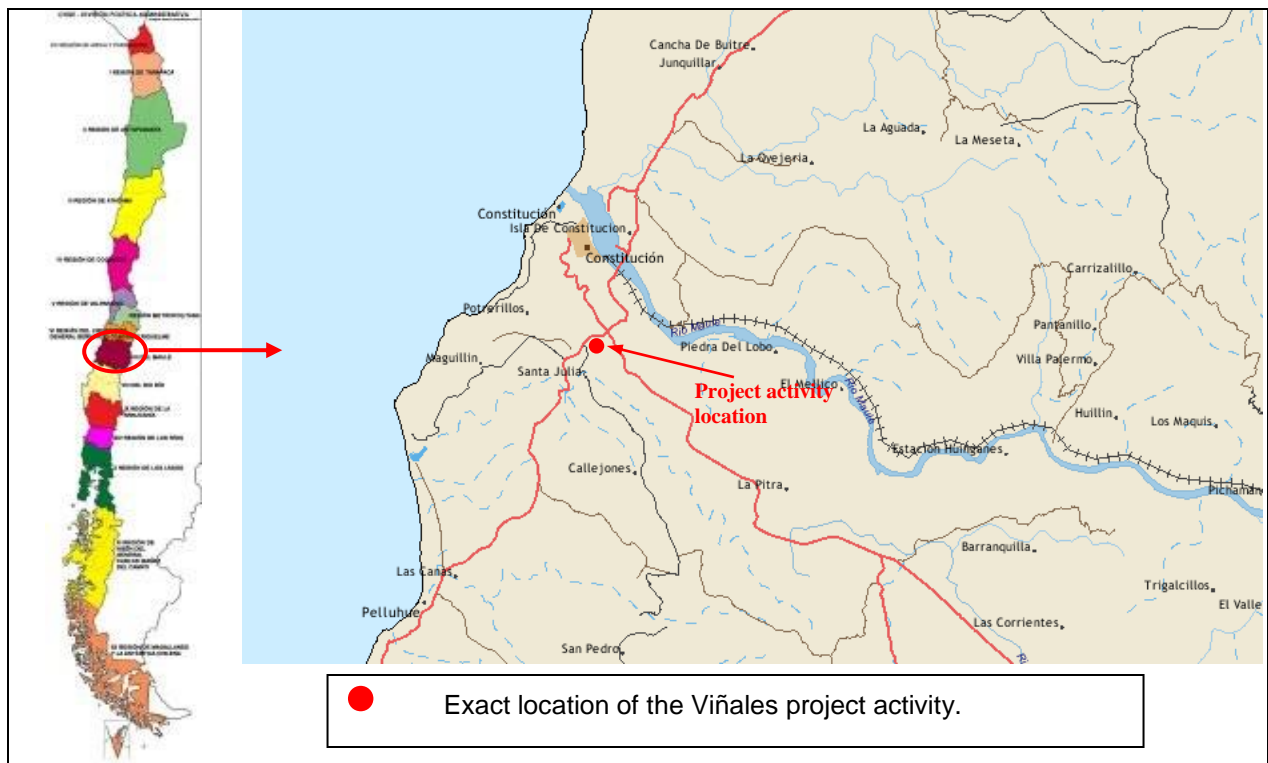

### 1.10 Conditions Prior to Project Initiation

Before the implementation of the project activity, the Viñales sawmill relied on an external company, Energía Verde, who supplied heat for wood drying, and on the grid for electric power. The proposed project activity is designed to integrate a new cogeneration power plant to the Viñales sawmill, in order to cogenerate heat and power for this facility and to export the remaining power to the grid. As a result of the proposed project activity, the Viñales sawmill will be self-sufficient in heat and electric power generation.

The proposed project by no means generates GHG emissions for the purpose of their subsequent reduction.

## 1.11 Compliance with Laws, Statutes and Other Regulatory Frameworks

According to the Chilean environmental regulations, since the proposed project activity does not generate a significant environmental impact, the Project Proponent must submit an Environmental Impact Declaration to the Environmental Authority. Such document was presented to the Environmental National Authority, CONAMA in August, 2008 and the corresponding letter of approval was obtained in March, 25<sup>th</sup>, 2009. As a result, the proposed project duly complies with all the regional and national laws, statutes and regulatory frameworks applicable in this case.

## 1.12 Ownership and Other Programs

### 1.12.1 Right of Use

The proposed project activity is implemented by Aserraderos Arauco S.A., a fully-owned subsidiary of Celulosa Arauco y Constitución S.A.

Aserraderos Arauco S.A. is the owner of the Viñales sawmill and the new cogeneration power plant. It is the entity that got the environmental approval of the CONAMA which is the Chilean DNA and the maximum environmental national authority in Chile. The corresponding approved DIA was presented to the DOE during the validation of this project and represents an official proof that Aserraderos Arauco S.A. is the owner of the proposed project activity.

### 1.12.2 Emissions Trading Programs and Other Binding Limits

The Project Proponent will show in each verification under VCS that the emission reductions associated to the Viñales project have not been used for compliance in any other emission trading program or to meet any kind of binding limits on GHG emissions.

### 1.12.3 Participation under Other GHG Programs

The Viñales project will participate in the ERNC market, created under the Law N° 20,257 of April, 2008 and therefore will generate non-conventional energy certificates. This mechanism, however, is a non-GHG related environmental mechanism, so there are no double-counting issues involved with the VCS program in this case. However, in case the VCS standard considers there are double-counting issues with the ERNC mechanism or any other mechanism the Viñales project might participate in the future, the Project Proponent will take all the necessary measures and safeguards in order to avoid any double-counting issues.

### 1.12.4 Other Forms of Environmental Credit

The Viñales project is not involved to any other form of GHG-related environmental credit for GHG emission reductions or removals other than the VCS Program.

### 1.12.5 Projects Rejected by Other GHG Programs

The Viñales project activity failed to obtain registration under the CDM in 2011, as it failed to comply with some procedural requirements related to additionality; in particular, with issues related to the early consideration of the CDM. Though the CDM was duly considered by the Project Proponent from the very early stages of the Viñales project activity's conception, the CDM rules for early consideration changed

and the evidence of early consideration presented to the CDM Executive Board for the Viñales CDM project was deemed invalid.

All the information related to the Viñales application to the CDM is available in the UNFCCC web page in the following link:

<http://cdm.unfccc.int/Projects/DB/DNV-CUK1287571838.72/view>

### **1.13 Additional Information Relevant to the Project**

#### **Eligibility Criteria**

Not applicable. The proposed project activity corresponds to a single project activity.

#### **Leakage Management**

The baseline methodology ACM0006 (Version 12.1.1) used in the Viñales project activity, duly accounts for any leakage effect the project activity might cause. In case of leakage, the corresponding emissions will be deducted from the project's emission reductions.

#### **Commercially Sensitive Information**

In this case there is no sensitive information that has been excluded from the public version of the project description document.

#### **Further Information**

There is no additional information that could affect the eligibility of proposed project activity, the net GHG emission reductions or the quantification of the project's net GHG emission reductions that should be mentioned in this section.

## **2 APPLICATION OF METHODOLOGY**

### **2.1 Title and Reference of Methodology**

The name of the approved baseline methodology applied to the proposed project activity is:

ACM0006 (Version 12.1.1), "Consolidated methodology for electricity and heat generation from biomass".

In the case of the proposed project activity, the baseline methodology also relies on the latest approved versions of the following methodological tools:

- Tool for the demonstration and assessment of additionality (Version 7.0.0).
- Tool to determine the baseline efficiency of thermal or electric energy generation systems. (Version 1.0).
- Tool to calculate the emission factor for an electricity system (Version 3.0.0).
- Tool to calculate project or leakage CO<sub>2</sub> emissions from fossil fuel combustion (Version 2.0).

- Tool to calculate baseline, project and/or leakage emissions from electricity consumption (Version 1.0).
- Tool for project and leakage emissions from transportation of freight (Version 1.1).

## 2.2 Applicability of Methodology

The proposed project activity consists in the installation of a new biomass-residue fired power plant, in a site where no power and heat was generated. The proposed project activity is a Greenfield power generation project.

The proposed project activity fully complies with all the applicability criteria of the ACM0006 (Version 12.1.1):

**1. No biomass types other than biomass residues are used in the project plant.**

The Viñales project will only use biomass residues as fuel in the power boiler (see point N°2).

**2. Fossil fuels may be co-fired in the project plant. However, the amount of fossil fuels co-fired will not exceed 80% of the total fuel fired on an energy basis.**

The primary fuel of the Viñales power plant are biomass residues from the forest industry (from nearby sawmills and from forestry operations). However, some fossil fuels may be co-fired in the power plant due to operational reasons (e.g. start-up operations, biomass too wet, etc.) and to enhance the economic performance of the plant. In both cases, the use of fossil fuels will be clearly lower than 80% of the total fuels fired on an energy basis.

**3. For projects that use biomass residues from a production process (e.g. production of sugar or wood panel boards), the implementation of the project does not result in an increase of the processing capacity of raw input (e.g. sugar, rice, logs, etc.) or in other substantial changes (e.g. product change) in this process.**

The implementation of the project will not increase the biomass production in the facility: The implementation of the proposed project activity cannot affect or alter in any way the production capacity of the Viñales sawmill, since the capacity of the facility is fixed and cannot change due to the implementation of the project activity. The sawmill production is determined by the sawn timber market conditions and not by the existence of the new power plant. In addition, the new power plant will use biomass residues which are already available from third parties. Therefore, it is not required for the Viñales sawmill to increase the production capacity of the raw input in order to generate more biomass residues and therefore more power. The new power plant can achieve full capacity operation by recurring to third-party biomass sources if so required.

**4. The biomass used by the project facility is not stored for more than one year.**

The biomass used in the project activity power boiler is stored in a dedicated place near the new Viñales power plant. The residence time of the stored biomass (total biomass residues stored / biomass residues consumption rate of the power plant) is less than two weeks. The biomass stockpile is conveniently managed in order to avoid that part(s) of the pile remain in the storing place for too long and suffer the consequent degradation of its fuel potential.

**5. The biomass residues used by the project facility are not obtained from chemically processed biomass (e.g. throughout esterification, fermentation, hydrolysis, pyrolysis, bio- or chemical- degradation, etc.) prior to combustion. Moreover, the preparation of biomass-derived fuel does not involve significant energy quantities, except from transportation or mechanical treatment so as not to cause significant GHG emissions.**

No significant energy quantities, except for transportation or mechanical treatment of the biomass residues are required to prepare the biomass residues for combustion. The Viñales biomass power plant only contemplates biomass transportation to the power plant and some mechanical processing of biomass from forestry operations.

6. **Applicability conditions N° 6, N° 7 and N°8 of the baseline methodology are not relevant in this case since the Viñales project activity is not a fuel-switch project, does not contemplate the use of biogas and does not use biomass residues from dedicated plantations.**
7. **The methodology is only applicable if the most plausible baseline scenario, as identified per the “Selection of the baseline scenario and demonstration of additionality” section hereunder is:**
  - **For power generation: Scenarios P2: to P7:, or a combination of any of those scenarios;**
  - **For heat generation: Scenarios H2: to H7:, or a combination of any of those scenarios;**
  - **For biomass residue use: Scenarios B1: to B8:, or any combination of those scenarios. For scenarios B5: to B8:, leakage emissions should be accounted for as per the procedures of the methodology.**

As will be shown in subsequent sections of this document, the baseline scenarios for power, heat and biomass use that are applicable to the Viñales project activity are among the ones specified above by the baseline methodology.

Furthermore, there is no mechanical power generation through the steam turbine installed under the project activity. All the steam energy is either used as process heat or transformed into electric power through the turbine and electricity generator (i.e. the Viñales power plant is a cogeneration power plant).

### 2.3 Project Boundary

| Source   |   | Gas              | Included? | Justification/Explanation   |
|----------|---|------------------|-----------|---|
| Baseline | Electricity and heat generation         | CO <sub>2</sub>  | Included  | Main emission source. It must be noted, that the proposed project activity does not claim emission reductions due to heat displacement. Heat generation is not influenced by the proposed project activity. Furthermore, heat generation in the new cogeneration facility is accomplished using renewable, carbon neutral biomass residues. |
|          |   | CH <sub>4</sub>  | Excluded  | Excluded for simplification. This is conservative.  |
|          |   | N <sub>2</sub> O | Excluded  | Excluded for simplification. This is conservative.  |
|          |   | Other            | None      | Not applicable.   |
|          | Uncontrolled burning of surplus biomass | CO <sub>2</sub>  | Excluded  | All biomass used in the project activity comes from renewable sources. It is assumed that CO <sub>2</sub> emissions from surplus biomass residues do not lead to changes of carbon pools in the LULUCF sector.  |

| Source                     |  | Gas              | Included?  | Justification/Explanation   |
|----------------------------|--|------------------|--|---|
|                            | residues                                       | CH <sub>4</sub>  | Included   | Surplus biomass (sawdust and bark) if not used for power generation is normally left in piles for uncontrolled burning (B3:) or natural decay (B1:).                                  |
|                            |  | N <sub>2</sub> O | Excluded   | Excluded for simplification. This is conservative. Note also that emissions from natural decay of biomass are not included in GHG inventories as anthropogenic sources <sup>a</sup> . |
|                            |  | Other            | None   | Not applicable.   |
| Project Activity           | On-site fossil fuel consumption                | CO <sub>2</sub>  | Included   | This emission source is not expected to be relevant (< 0.2% of baseline emissions), however it will be considered.  |
|                            |  | CH <sub>4</sub>  | Excluded   | Excluded for simplification. This emission source is assumed to be very small. <sup>b</sup>   |
|                            |  | N <sub>2</sub> O | Excluded   | Excluded for simplification. This emission source is assumed to be very small. <sup>b</sup>   |
|                            |  | Other            | None   | Not applicable.   |
|                            | Off-site transportation of biomass residues    | CO <sub>2</sub>  | Included   | This emission source is not expected to be relevant (< 4% of baseline emissions), however it will be considered.  |
|                            |  | CH <sub>4</sub>  | Excluded   | Excluded for simplification. This emission source is assumed to be very small. <sup>b</sup>   |
|                            |  | N <sub>2</sub> O | Excluded   | Excluded for simplification. This emission source is assumed to be very small. <sup>b</sup>   |
|                            |  | Other            | None   | Not applicable.   |
|                            | Combustion of biomass for electricity and heat | CO <sub>2</sub>  | Excluded   | It is assumed that CO <sub>2</sub> emissions from surplus biomass do not lead to changes of carbon pools in the LULUCF sector.  |
|                            |  | CH <sub>4</sub>  | Included   | This emission source must be included, since CH <sub>4</sub> emission from uncontrolled burning or decay of biomass residues in the baseline scenario are included.                   |
|                            |  | N <sub>2</sub> O | Excluded   | Excluded for simplification. This emission source is assumed to be small.   |
|                            |  | Other            | None   | Not applicable.   |
|                            | Storage of biomass                             | CO <sub>2</sub>  | Excluded   | It is assumed that CO <sub>2</sub> emissions from surplus biomass residues do not lead to changes of carbon pools in the LULUCF sector.   |
|                            |  | CH <sub>4</sub>  | Excluded   | Excluded for simplification. Since biomass residues are stored for not longer than one year, the emission source is assumed to be small.  |
|                            |  | N <sub>2</sub> O | Excluded   | Excluded for simplification. This emission source is assumed to be very small.  |
|                            |  | Other            | None   | Not applicable.   |
| Waste water from treatment | CO <sub>2</sub>                                | Excluded         | It is assumed that CO <sub>2</sub> emissions from surplus biomass residues do not lead to changes of carbon pools in the |   |

| Source   |  | Gas              | Included? | Justification/Explanation  |
|--|--|------------------|-----------|--|
| of biomass residues                              |  |                  |           | LULUCF sector.   |
|  |  | CH <sub>4</sub>  | Excluded  | This emission source shall be included in cases where the waste water is treated (partly) under anaerobic conditions. Since the proposed project activity does not originate wastewater from biomass treatment, this emission source is excluded in this case. |
|  |  | N <sub>2</sub> O | Excluded  | Excluded for simplification. This emission source is assumed to be small.  |
|  |  | Other            | None      | Not applicable.  |
| Cultivation of land to produce biomass feedstock |  | CO <sub>2</sub>  | Excluded  | This emission source is excluded in this case, since the proposed project activity does not use biomass from dedicated plantations.  |
|  |  | CH <sub>4</sub>  | Excluded  | This emission source is excluded in this case, since the proposed project activity does not use biomass from dedicated plantations.  |
|  |  | N <sub>2</sub> O | Excluded  | This emission source is excluded in this case, since the proposed project activity does not use biomass from dedicated plantations.  |
|  |  | Other            | None      | Not applicable.  |

a. Note that the emission factors for CH<sub>4</sub> and N<sub>2</sub>O emissions from uncontrolled burning or decay of dumped biomass residues are highly uncertain and depend on many site-specific factors. Quantification is difficult and may increase transaction costs significantly. Note also that CH<sub>4</sub> and N<sub>2</sub>O emissions from the natural decay or uncontrolled burning are in some cases (e.g. natural decay of forest residues) not anthropogenic sources of emission included in Annex A of the Kyoto Protocol and should not be included in the calculation of baseline emissions pursuant to paragraph 44 of the modalities and procedures for the CDM.

b. CH<sub>4</sub> and N<sub>2</sub>O emission factors depend significantly on the technology (e.g. vehicle type) and may be difficult to determine for project participants. Exclusion of this emission source is not a conservative assumption; however, it appears reasonable, since CH<sub>4</sub> and N<sub>2</sub>O from on-site use of fossil fuels and transportation are expected to be very small compared to overall emission reductions, and since it simplifies the determination of emission reductions significantly.

According to the ACM0006 (Version 12.1.1), the Project Proponent must provide an explanation in the project document of the specific situation of the project activity. This information is provided in the tables below:

|  |   |
|--|---|
| <b>For each plant generating power and/or heat that has been operated at the project site within the most recent three years prior to the start of the project activity:</b> |   |
| Type and capacity of the heat generators:  | There were no heat and/or power plants operating at the project site before the implementation of the project activity. |
| The types and quantities of fuels which have been used in the heat generators:   | Not applicable, see the answer above.   |

|  |                                       |
|--|---------------------------------------|
| The types and capacities of heat engines:  | Not applicable, see the answer above. |
| Whether the equipment continues operation after the start of the project activity: | Not applicable, see the answer above. |

| <b>For each plant generating power and/or heat installed under the project activity:</b> |  |
|--|--|
| The type and capacity of the heat generators:  | Biomass power boiler: 210 (ton high-pressure steam/hr) with biomass fuels. The capacity can increase to 250 (ton high-pressure steam/hr) if biomass fuels are complemented with some fossil fuel.  |
| The types and quantities of fuels used in the heat generators:                           | Power boiler: <ul style="list-style-type: none"> <li>• Internal biomass from industrial operations: 149,203 (BDt/yr).</li> <li>• 3<sup>rd</sup> party biomass from industrial operations: 128,052 (BDt/yr).</li> <li>• 3<sup>rd</sup> party biomass from forestry operations: 35,500 (BDt/yr).</li> <li>• Fuel oil: 0 (ton/yr).</li> <li>• Diesel: 50 (ton/yr).</li> </ul>   |
| The type and capacity of heat engines and direct heat extractions:                       | One condensing-extracting turbine: <ul style="list-style-type: none"> <li>• Capacity of the turbine at the turbine coupling: 39.99 MW.</li> <li>• Capacity of heat extraction N°1: 31 (ton/hr), medium-pressure steam.</li> <li>• Capacity of heat extraction N°2: 42 (Kg/s), low-pressure steam.</li> <li>• Exhaust flow (to the condenser): 111.6 (ton/hr)</li> </ul> <p>(Note: The capacities above correspond to the Nuovo Pignone Viñales Performance Table, under the "Max Condenser 2" operating scenario).</p> |

| <b>For each plant generating power and/or heat that would be installed in the absence of the project activity:</b> |   |
|--|---|
| The type and capacity of the plant:  | Type: Saturated steam plant.<br><br>Capacity: 75 (ton/hr) of 20 bar saturated steam.  |
| Type and capacity of heat generators:  | Heat generator capacity: 75 (ton/hr) of 20 bar saturated steam.   |
| Type and capacity of heat engines:   | There would be no heat engines in this case.  |
| Type and capacity of electric power generators:  | There would be no electric power generators in this case.   |
| Types and quantities of fuels which would be used in each heat generator:  | Saturated steam boiler: <ul style="list-style-type: none"> <li>• Internal biomass from industrial operations: 104,900 (BDt/yr).</li> <li>• Diesel: 0 (ton/yr).</li> </ul> |

| <b>The average amounts of electricity and heat import from off-site sources that would happen in the absence of the project activity on a yearly basis and the forecast for the project scenario:</b> |  |
|---|--|
| Average amount of electricity and heat import from off-site sources in the absence of the project activity:   | Electricity imports: 80.6 (GWh/yr) from the grid.<br>Heat imports: 0 (GJ/yr). The baseline plant would be self-sufficient in heat generation. The baseline plant would not receive heat from off-site sources in the absence of the project activity.  |
| Average amount of electricity and heat import from off-site sources under the project activity:   | Electricity imports: 1.5 (GWh/yr) from the grid. The project plant would produce a considerable amount of surplus power to the grid. However, small amounts of power from the grid would be required under certain circumstances (e.g. plant stops and start-up operations). This power amount is highly variable, therefore, though it will be monitored and duly accounted for, it will not be considered in the emission reduction calculation in this document.<br><br>Heat imports: 0 GJ/yr. The project plant would be self-sufficient in heat generation. The project plant would not receive heat from off-site sources. |

## 2.4 Baseline Scenario

According to the ACM0006 (Version 12.1.1), project participants shall identify the most plausible baseline scenario and demonstrate additionality applying the following steps.

### **Step 1: Identification of alternative scenarios.**

Step 1a: Definition of alternative scenarios to the proposed CDM project activity

Considering that the ACM0006 (Version 12.1.1) includes several project scenarios that reasonably cover all possibilities for power generation, heat generation and biomass use that can be considered in this case, the baseline analysis will be carried out for all the project scenarios outlined in the methodology for power generation (PX), heat generation (HX) and biomass use (BX).

#### Project scenarios for power generation

| Scenario | Scenario description  | Feasibility in the context of the proposed project activity        |
|----------|---|--|
| P1:      | The proposed project activity not undertaken as a VCS project activity.   | Yes.   |
| P2:      | If applicable, the continuation of power generation in existing power plants at the project site. The existing plants would operate at the same conditions (e.g. installed capacities, average load factors, or average energy efficiencies, fuel mixes and equipment configuration) as those observed in the most recent three years prior to the starting date of the project activity. | Not applicable.<br><br>Currently, power is obtained from the grid. |
| P3:      | If applicable, the continuation of power generation in existing power plants at the project site. The existing plants would operate with different conditions from those  | Not applicable.<br><br>Currently, power is obtained                |

|     |   |  |
|-----|---|--|
|     | observed in the most recent three years prior to the starting date of the project activity.   | from the grid.   |
| P4: | If applicable, the retrofitting of existing power plants at the project site. The retrofitting may or may not include a change in fuel mix. | Not applicable.<br>Currently, power is obtained from the grid.   |
| P5: | The installation of new power plants at the project site different from those installed under the project activity.                         | Yes.   |
| P6: | The generation of power in specific off-site plants, excluding the power grid.  | No.<br>In the Viñales project context, there are no off-site power plants available from where to source electric power. |
| P7: | The generation of power in the power grid.  | Yes.<br>This corresponds to the current situation.   |

The feasible baseline scenarios for power generation would be: P1, P5 and P7.

Project scenarios for heat generation

| Scenario | Scenario description  | Feasibility in the context of the proposed project activity          |
|----------|---|--|
| H1:      | The proposed project activity not undertaken as a VCS project activity.   | Yes.   |
| H2:      | If applicable, the continuation of heat generation in existing plants at the project site. The existing plants would operate at the same conditions (e.g. installed capacities, average load factors, or average energy efficiencies, fuel mixes and equipment configuration) as those observed in the most recent three years prior to the project activity. | Not applicable.<br>There are no existing plants at the project site. |
| H3:      | If applicable, the continuation of heat generation in existing plants at the project site. The existing plants would operate with different conditions from those observed in the most recent three years prior to the project activity.  | Not applicable.<br>There are no existing plants at the project site. |
| H4:      | If applicable, the retrofitting of existing plants at the project site. The retrofitting may or may not include a change in fuel mix.   | Not applicable.<br>There are no existing plants at the project site. |
| H5:      | The installation of new plants at the project site different from those installed under the project activity.   | Yes.   |
| H6:      | The generation of heat in specific off-site plants.   | No<br>This option is no longer available for the Viñales sawmill.    |
| H7:      | The production of heat from district heating.   | No.<br>District heating is neither available nor developed in        |

|  |        |
|--|--------|
|  | Chile. |
|--|--------|

The feasible baseline scenarios for heat generation would be: H1 and H5.

In the case of the Viñales project activity, there is no mechanical power generation (i.e. baseline scenarios M) and / or the use of biogas (i.e. baseline scenarios BG). As a result, the alternative scenarios for mechanical power will not be considered in this case.

### Project scenarios for biomass use

| <b>Scenario</b> | <b>Scenario description</b>   | <b>Feasibility in the context of the proposed project activity</b>   |
|-----------------|---|--|
| B1:             | The biomass residues are dumped or left to decay under mainly aerobic conditions. This applies, for example, to dumping and decay of biomass residues on fields.  | Yes.<br><br>This would be a likely baseline scenario for the additional biomass used to generate power.  |
| B2:             | The biomass residues are dumped or left to decay under clearly anaerobic conditions. This applies, for example, to landfills which are deeper than 5 meters. This does not apply to biomass residues that are stock-piled or left to decay on fields. | No.<br><br>Normally, the biomass is just dumped in stock-piles.  |
| B3:             | The biomass residues are burnt in an uncontrolled manner without utilizing them for energy purposes.  | Yes.<br><br>This would be a likely baseline scenario for the additional biomass used to generate power.  |
| B4:             | The biomass residues are used for power or heat generation in new and/or existing plants.   | Yes.<br><br>This would be the baseline scenario for the biomass residues used for heat generation.   |
| B5:             | The biomass residues are used for power or heat generation at other sites in new and/or existing plants.  | No.<br><br>Considering the surplus amount of biomass residues available in the region, the biomass residues that would be used for power generation under the project scenario would most likely be left to decay or burned in the open air under the baseline scenario. |
| B6:             | The biomass residues are used for other energy purposes, such as the generation of biofuels.  | No.<br><br>The generation of biofuels using forestry biomass residues (sawdust and bark) is not developed at an  |

|     |  |  |
|-----|--|--|
|     |  | industrial scale in Chile (and in the world) to date.  |
| B7: | The biomass residues are used for non-energy purposes, e.g. as fertilizer or as feedstock in processes (e.g. in the pulp and paper industry).  | No.<br><br>The biomass residues used for heat and/or power generation at the Viñales power plant are not used for feedstock or for pulp and paper production.  |
| B8: | Biomass residues are purchased from a market or biomass residues retailers, or the primary source of the biomass residues and/or their fate in the absence of the project activity cannot be clearly identified. | No.<br><br>Considering the surplus amount of biomass residues available in the region, the additional biomass consumed by the project plant would be simply left to decay or burned in the open air. |

Depending on the project options and biomass types, the feasible baseline scenarios for the biomass use would be: B1, B3 and B4.

Considering the analysis above, the baseline scenarios for the biomass residues can be established as follows:

| Biomass residues categories (k) | Biomass residues type                        | Biomass residues source | Biomass residues fate in the absence of the project activity | Biomass residues use in project scenario                              | Biomass residues quantity (dry tonnes/yr) |
|---------------------------------|--|-------------------------|--|---|---|
| 1                               | Sawdust and bark from industrial operations. | On-site production.     | Heat generation on-site (B4:).                               | Heat and electric power generation on-site (one biomass-only boiler). | 65,417                                    |
| 2                               | Sawdust and bark from industrial operations. | On-site production.     | Dumped and/or burned in the open air (B1: and/or B3:).       | Heat and electric power generation on-site (one biomass-only boiler). | 83,786                                    |
| 3                               | Sawdust and bark from industrial operations. | Off-site production.    | Dumped and/or burned in the open air (B1: and/or B3:).       | Heat and electric power generation on-site (one biomass-only boiler). | 128,052                                   |
| 4                               | Biomass from forestry operations.            | Off-site production.    | Dumped and/or burned in the open air (B1: and/or B3:).       | Heat and electric power generation on-site (one biomass-only boiler). | 35,500                                    |

According to the table above, it is clear that in this particular case the proposed project activity implies an additional consumption of biomass from industrial operations and from forestry operations for electric power generation. It must be noted that when sawmills have served their internal need for heat, they sell the surplus to local consumers (if possible) or simply burn or discard the surplus in landfills.

According to the ACM0006 (Version 12.1.1), for biomass residues categories for which scenarios B1:, B2: or B3: are deemed plausible baseline alternatives, project participants must demonstrate that these are realistic and credible alternative scenarios. To do this, the Project Proponent will demonstrate that for the biomass residues used in the project activity that:

- There is an abundant surplus of the type of biomass residue in the region of the project activity which is not utilized. For this purpose, the Project Proponent will demonstrate that the quantity of that type of biomass residue available in the region is at least 25% larger than the quantity of biomass residue of that type which is utilized in the region (e.g. for energy generation or as feedstock), including the project plant demand.

Since there is a considerable surplus of unused biomass from industrial operations in the region in which the Viñales power plant is located, the baseline for the surplus biomass generated by the Viñales sawmill as well as the baseline for the additional biomass that would be used for electric power generation (both from industrial and from forestry operations) is the disposal or the uncontrolled burning of the biomass residues (B1: and/or B3:).

To show that there is a surplus of unused biomass residues in the Viñales region, the Project Proponent performed a detailed research of the biomass supply/demand situation in the region. The results are shown in the table below:

**Supply / Demand situation in the Viñales power plant influence area**  
(Estimation for year 2009)

**Biomass residues supply**

|                                    |                             |                  |
|------------------------------------|-----------------------------|------------------|
| Biomass from industrial operations | (m <sup>3</sup> st/yr)      | 4,818,310        |
| Biomass from forestry operations   | (m <sup>3</sup> st/yr)      | 1,796,143        |
| <b>Total supply</b>                | <b>(m<sup>3</sup>st/yr)</b> | <b>6,614,452</b> |

**Biomass residues demand**

|                                   |                             |                  |
|-----------------------------------|-----------------------------|------------------|
| Demand from industrial operations | (m <sup>3</sup> st/yr)      | 3,236,930        |
| Demand from forestry operations   | (m <sup>3</sup> st/yr)      | 870,933          |
| <b>Total demand</b>               | <b>(m<sup>3</sup>st/yr)</b> | <b>4,107,863</b> |

**Sources:** Infor official bulletins, studies and Arauco forest databases.

**Viñales power plant surplus index**  
(Estimation for year 2009)

This index was calculated using criteria "L2" of the ACM0006 (Version 09)

|   |                 |               |
|---|-----------------|---------------|
| Biomass from industrial operations / Total biomass demand | (number)        | 1.4885        |
| Biomass from forestry operations / Total biomass demand   | (number)        | 2.0623        |
| <b>Total supply / Total demand</b>                        | <b>(number)</b> | <b>1.6102</b> |

According to the information above, the Viñales biomass power plant project counts with sufficient biomass locally and will not cause other biomass plants in the area to switch from biomass to fossil fuels.

According to the ACM0006 (Version 12.1.1), the Project Proponent must clearly identify the relevant geographical region in order to identify the relevant alternative scenarios. In this case, the relevant geographical region will be the host country: Chile. The reason for choosing the host country as the relevant geographical region is that it counts with several facilities in the Sawmill and Panel board industries; therefore it can be used reliable to establish the baseline scenario for the Viñales project.

In the following tables below, the Project Proponent presents the different project alternatives that consider the baseline scenarios for power, heat and biomass use identified above. In each case it is addressed the feasibility of the project option of becoming the baseline scenario for the proposed project as well as the situation of power and heat generation, the biomass consumption and how this situation compares to the one observed under the project scenario. Finally, it also addressed what would happen to any differences in power and heat generation and biomass consumption between each alternative and the project plant, in the absence of the proposed project activity.

**1.0 A low-pressure boiler on biomass fuels.**

The generation of saturated steam for heating purposes is a normal practice in the Sawmill and Panel board industries in Chile. In this case it is a realistic and plausible project scenario, since the Viñales sawmill requires heat for wood drying.

Technical assumptions:

Installed capacities:

Saturated steam power boiler: 75 ton/hr, 20 bar(a), 214.5 °C.

Load factor: 80%

Power boiler efficiency: 60%

Fuel mixes:

- Internal biomass from industrial operations: 90,000 (BDt/yr)
- 3<sup>rd</sup> party biomass from industrial operations: 14,900 (BDt/yr)
- 3<sup>rd</sup> party biomass from forestry operations: 0 (BDt/yr)
- Fuel Oil: 0

Power generation: Since there would be no power generation in the Viñales sawmill site, all the power contemplated under the project activity scenario would be generated in grid-connected power plants.

- The applicable baseline for all the power generation would be: P7.

Heat generation: All the heat required by the Viñales sawmill would be generated in the new boiler, using biomass residues.

- The applicable baseline scenario for the heat would be: H5.

Biomass residues: In this case, the consumption of biomass residues in the Viñales sawmill site would be determined by the generation of steam for heating purposes. For that reason, the biomass consumption would mainly include internal biomass residues and a small fraction of 3<sup>rd</sup> party biomass residues from industrial operations. The rest of the biomass residues contemplated under the project activity would be discarded and not used for energy purposes.

The applicable baseline scenarios for the biomass types would be:

- Internal biomass from industrial operations: B4 (used for heat generation in the plant considered under this project scenario).
- 3<sup>rd</sup> party biomass from industrial operations: B4 (the fraction used for heat generation in the plant considered under this project scenario).
- 3<sup>rd</sup> party biomass from industrial operations: B1 and/or B3 (the remaining fraction considered under the project activity scenario)
- 3<sup>rd</sup> party biomass from forestry operations: B3 (the amount considered under the project activity scenario).

Note that if the internal biomass residues are enough to generate the heat required by the Viñales sawmill, the biomass categories and baselines would be as follows:

- Internal biomass from industrial operations: B4 (the fraction used for heat generation under the project activity scenario).
- Internal biomass from industrial operations: B1 (the fraction used for power generation under the project activity scenario).
- 3<sup>rd</sup> party biomass from industrial operations: B1 and/or B3 (used for power generation under the project scenario).
- 3<sup>rd</sup> party biomass from forestry operations: B3 (used for power generation under the project activity scenario).

|  |
|--|
|  |
|--|

**2.0 A new cogeneration power plant on biomass fuels, implemented with a lower efficiency/scale.**

The cogeneration of electric power in the context of the Sawmill and Panel board industries is not a normal practice in Chile.

Technical assumptions:

High-pressure steam boiler: 90 ton/hr, 41 bar(a), 420 °C.

Power boiler efficiency: 84%.

Condensing – extracting turbine: 15 MW nominal capacity.

Cogeneration plant load factor: 95%.

Fuel mixes:

- Internal biomass from industrial operations: 112,758 (BDt/yr).
- 3<sup>rd</sup> party biomass from industrial operations: 27,829 (BDt/yr).
- 3<sup>rd</sup> party biomass from forestry operations: 0 (BDt/yr).
- Fuel Oil: 0.

It must be noted that the capacity and / or efficiency of the less efficient cogeneration power plant could vary from the above. This variation, however, would not change the result of the analysis below.

Power generation: Power would be generated in the new cogeneration power plant. Part of this power would be for self-consumption, while the remaining power would be available to the grid. Since this cogeneration plant would generate less power than the cogeneration plant considered under the proposed project activity scenario, the remaining power would be generated by grid-connected power plants.

The applicable baseline for power generation would be:

- The power generated in this cogeneration power plant: P5.
- The remaining power considered under the proposed project activity: P7.

Heat generation: All the heat required by the Viñales sawmill would be generated in the cogeneration plant, using biomass residues.

- The applicable baseline scenario for the heat would be: H5.

Biomass residues: As in the proposed project activity, the same biomass types but with lower amounts would be used as fuel for heat and power generation in the power plant.

The applicable baseline scenarios for the biomass types would be:

- Internal biomass from industrial operations: B4 (used for heat and power generation in the power plant considered under this project scenario).
- 3<sup>rd</sup> party biomass from industrial operations: B4 (the fraction used for heat and power generation in the power plant considered under this project scenario).
- 3<sup>rd</sup> party biomass from industrial operations: B1 and/or B3 (the remaining fraction considered under the project activity scenario).
- 3<sup>rd</sup> party biomass from forestry operations: B3 (the amount considered under the project activity

scenario).

**3.0 The proposed project activity**

The cogeneration of electric power in the context of the Sawmill and Panel board industries is not a normal practice in Chile.

Technical assumptions:

Under this scenario, installed capacities, load factors, energy efficiencies, fuel mixes and equipment configuration correspond to the ones considered under the proposed project activity and are fully described in this document. Therefore they will not be presented in this section again.

Power generation: Power would be generated in the new cogeneration power plant. Part of this power would be for self-consumption, while the remaining power would be available to the grid.

- The applicable baseline for all the power generation in the power plant would be: P1.

Heat generation: All the heat required by the Viñales sawmill would be generated in the cogeneration power plant, using biomass residues.

- The applicable baseline scenario for the heat would be: H1.

Biomass residues: As in the proposed project activity, the same biomass types and amounts would be used as fuel for heat and power cogeneration in the power plant.

The applicable baseline scenarios for the biomass types would be:

- Internal biomass from industrial operations: B4.
- 3<sup>rd</sup> party biomass from industrial operations: B4.
- 3<sup>rd</sup> party biomass from forestry operations: B4.

According to the above, the list of plausible and realistic alternative scenarios to the proposed VCS project activity (outcome of step 1a) would be:

1. The installation of a low-pressure boiler on biomass fuels.
2. The installation of a new cogeneration power plant on biomass fuels, implemented with a lower efficiency/scale.
3. The proposed project activity.

Step 1b: Consistency with mandatory applicable laws and regulations

Once the relevant permits are obtained from the corresponding national authorities, all the alternative project options identified above fully comply with all the mandatory applicable legal and regulatory requirements. This can be clearly demonstrated as there are several examples in the Sawmill and Panel board industries in Chile in which these project options have been actually implemented<sup>1</sup>.

---

<sup>1</sup> In the case of cogeneration power plants, most of the examples correspond to Project activities under the Clean Development Mechanism (CDM).

**Step 2: Barrier analysis.**

Step 2a: Identify barriers that would prevent the implementation of alternative scenarios.

The Project Proponent identified the following set of barriers that prevent alternative scenarios to occur:

Investment barriers:

- With the prevailing conditions in Chile, biomass power generation projects do not present very high financial returns. This is supported by the low share of this type of technology in the Chilean power matrix. In the particular case of the proposed project activity, the low financial returns will be further substantiated in a later section of this document.
- The proposed project activity contemplates the construction of a new grid-connected biomass power plant on the Viñales sawmill site. This implies additional risks and/or costs to Arauco. For example, any contingency in the power system (e.g. black-out), normally translates into an economic penalty that is applied to all power producers in the system, regardless of which company was responsible for the contingency<sup>2</sup>. Arauco has paid around US\$ 130,000 in fines to the corresponding national authority. The original amount, however, was approximately 7 times higher. In each case, Arauco had to appeal to the corresponding national authority.

Given the limited amount of information related to penalties available from other power companies (this information is not public) and the high level of uncertainty related to the fines actually paid by the companies (court disputes with the national authority are private), it is not possible to reliably translate this risk into an additional cost, in order to incorporate it into the financial evaluation of this type of projects.

Technological barriers:

Being biomass power cogeneration a technology not common in the context of the Sawmill industry in Chile, projects using cogeneration face several technological barriers:

- Skilled and/or properly trained labor to operate and maintain grid-connected cogeneration plants is not readily available in Chile. This translates into additional risks of underperformance, malfunctioning or accident.

A cogeneration power plant is considerably more sophisticated and complex to operate than a conventional low pressure boiler. According to specialized literature<sup>3</sup>, poor operational and maintenance skills generally translate into improper operation, which in the long-run result into early deterioration and failure of the power generation equipment. Skillful and fully involved personnel are crucial to achieve optimal plant operation and a low breakdown rate.

The required skills to operate and maintain this kind of cogeneration plants is not readily available in Chile and particularly in the Sawmill industry, since power generation is not part of the common practice in this industry. There are not many big-scale biomass cogeneration facilities operating as

---

<sup>2</sup> Historically, penalties have been applied in proportion to the owner's total generation capacity. Some penalizations that have been applied to Arauco can be found in RE 1433, pages 13-14, RE 809, page 16 and RE 1114 pages 13-14.

<sup>3</sup> For example, refer to chapter 14 of the "Handbook for cogeneration and combined cycle power plants" by Dr. Meherwan P. Boyce, P.E, 2002 or public papers in the field such as "Assessment of Training Needs for Cogeneration Technology in Schuylkill County" by Gary D. Geroy and David L. Passmore, 1987.

power plants in Chile<sup>4</sup> and other than Arauco, there is no other company in Chile that operates a cogeneration facility as a self-power producer<sup>5</sup> in the grid.

Furthermore, according to national statistics<sup>6</sup>, people tend not to accept or stay long in job positions that are based in another country region. This restricts the universe of potential candidates and contributes to a high-job rotation, which tends to perpetuate the lack of experience problem for high-level technical positions. As a result, it is usual that the power plant owner ends up hiring people with lower competencies, who are not sufficiently qualified for the job.

- Risk of technological failure: The integration of a high-pressure extracting turbine with low-pressure steam equipment such as sawmills and panel board mills present higher operational risks than those observed in conventional facilities. Heat in sawmills is used for wood drying, and drying is done in batches. This translates into high fluctuations in steam demand for heating. These fluctuations have the following adverse effects:
  - The high steam demand fluctuations make the turbo generator to operate in areas of low efficiencies. In some extreme cases, low steam flows through the turbo generator may cause system trips. This can be clearly seen in the efficiency versus steam load chart of a turbo generator machine<sup>7</sup> (provided by turbo generator vendors).
  - The fluctuations also compromise the power generation capacity of the cogeneration plant, forcing the power plant to reduce its power generation to the grid. If this situation happens during a peak power demand period, the plant may be penalized on its future power revenues by the Dispatch Center for non-compliance with the dispatch program. This is not a minor issue, considering that currently approximately 25% of the annual revenue of a power plant of this type corresponds to firm power sales.
  - The normal design of the drying chamber heating systems for sawmills in Chile do not contemplate separate pipes for each consumer. This would be far too expensive and difficult to do with the large number of heat consumers in a sawmill. As a result, condensates from different processes meet in the condensate pipes. Some condensates are so hot that they form flash steam while some others are colder than the saturation temperatures in the pipe. The mixing of these two types of condensates leads to implosions inside the pipes and a very noisy “hammering”. The hammering often leads to damage to the piping, valves, steam traps, etc. It could also lead to cracks in the system, so untreated water could enter the condensate system and contaminate the returned condensate to the boiler. This problem could seriously compromise the technical life of a high-pressure boiler, whereas it would be much less relevant in the case of a saturated steam boiler. This problem was described in a study carried out in December, 2007 by AF Celpap made for another cogeneration power plant owned by Arauco, currently registered as a CDM project. The study looked at operational problems of a cogeneration plant that provides heat to a sawmill and a panel board facility.

It must be noted that since there are very few sawmills in Chile that operate with integrated cogeneration power plants (see official statistics below), it is not possible to reliably translate these barriers into

---

<sup>4</sup> Please refer to the list of grid-connected biomass power plants in the SIC interconnected system in Chile in Annex 3 of this PDD.

<sup>5</sup> A self-power producer is a modality contemplated in the CDEC-SIC Dispatch Center regulation, under which a company that has surplus power generating capacity is allowed to operate as a grid-connected power plant in the grid, declaring only its surplus power capacity to the system.

<sup>6</sup> According to 1992-2002 migration study by the National Statistics Institute (INE, Spanish abbreviation).

<sup>7</sup> As supporting evidence, please see figure 6 in page 6 of the document “Steam Turbine Thermal Evaluation” by Paul Albert. This is a GE document and is available in the web at: <[http://www.ge-energy.com/prod\\_serv/products/tech\\_docs/en/downloads/ger4190.pdf](http://www.ge-energy.com/prod_serv/products/tech_docs/en/downloads/ger4190.pdf)>

additional cost. However, the low occurrence of this type of projects in Chile (even in the context of other big forest companies in Chile) clearly demonstrates that these barriers are real.

According to the “Guidelines for objective demonstration and assessment of barriers” approved in the EB 50, it is suggested that the Project Proponent complement the information provided above with information related to the nature of the company, the organization and its ownership, as well as with its previous experience with similar projects as the proposed project activity.

Arauco is a leading forest company in Chile and has the following business units:

- Forestry division.
- Pulp division.
- Sawmill division.
- Wood panel division.
- Power division. This division was created to provide commercial services to the other divisions for selling the additional power to the grid (e.g. from other power generation CDM projects).

Arauco is fully owned by COPEC, a leading fuel distribution company in Chile. Arauco owns two biomass power generation projects in Chile that are similar (in context and technology) to the proposed project activity. Both projects are currently registered under the CDM. This past experience does contribute to mitigate some of the technological barriers outlined above. However, some of the barriers still persist, since they are structural to the industry contexts in which these type of projects are implemented (e.g. Sawmill and Panel board industries) and tend to prevail regardless of the Project Proponent’s past experience (e.g. sawmill drying chamber configuration, sawmill drying regime, turbo generator efficiency range, etc.).

The significance of the technological barriers mentioned above can be substantiated by considering the marginal use of the biomass power cogeneration technologies in the Power and Forest (e.g. Sawmill and Panel board) industries in Chile:

Use of the biomass power generation technology in the Power industry in Chile:

According to the most recent national statistics available, non-conventional renewable power generation capacity accounts for just 3% of the total power generation capacity installed in Chile. Furthermore, biomass power generation (available to the grid) merely represents 1.3% of the total power generation capacity in Chile. This is illustrated in the following table and graph below:

**Power generation capacity per technology type in Chile, 2008<sup>8</sup>**

| Source  |             | Interconnected transmission systems |              |             |              | Total         |
|---|-------------|-------------------------------------|--------------|-------------|--------------|---------------|
|   |             | SIC                                 | SING         | Magallanes  | Aysén        |               |
| Hydro (> 20 MW)                               | (MW)        | 4,781                               | 0            | 0           | 0            | 4,781         |
| Fossil fuels                                  | (MW)        | 4,292                               | 3,589        | 99          | 28           | 8,008         |
| <b>Total conventional</b>                     | <b>(MW)</b> | <b>9,073</b>                        | <b>3,589</b> | <b>99</b>   | <b>28</b>    | <b>12,789</b> |
| Hydro (< 20 MW)                               | (MW)        | 129                                 | 13           | 0           | 21           | 163           |
| Biomass                                       | (MW)        | 166                                 | 0            | 0           | 0            | 166           |
| Wind  | (MW)        | 18                                  | 0            | 0           | 2            | 20            |
| <b>Total non-conventional renewable power</b> | <b>(MW)</b> | <b>313</b>                          | <b>13</b>    | <b>0</b>    | <b>23</b>    | <b>349</b>    |
| <b>Total national level</b>                   | <b>(MW)</b> | <b>9,386</b>                        | <b>3,602</b> | <b>99</b>   | <b>51</b>    | <b>13,138</b> |
| <b>Percentage ERNC</b>                        | <b>(%)</b>  | <b>3.3%</b>                         | <b>0.4%</b>  | <b>0.0%</b> | <b>45.1%</b> | <b>2.7%</b>   |
| <b>Percentage Biomass</b>                     | <b>(%)</b>  | <b>1.8%</b>                         | <b>0.0%</b>  | <b>0.0%</b> | <b>0.0%</b>  | <b>1.3%</b>   |

Source: CNE statistics for 2008. Available at: <[http://www.cne.cl/cnewww/opencms/06\\_Estadisticas/energia/ERNc.html](http://www.cne.cl/cnewww/opencms/06_Estadisticas/energia/ERNc.html)>.

<sup>8</sup> ERNC stands for “Energías Renovables No Convencionales” (Non-conventional renewable energies).

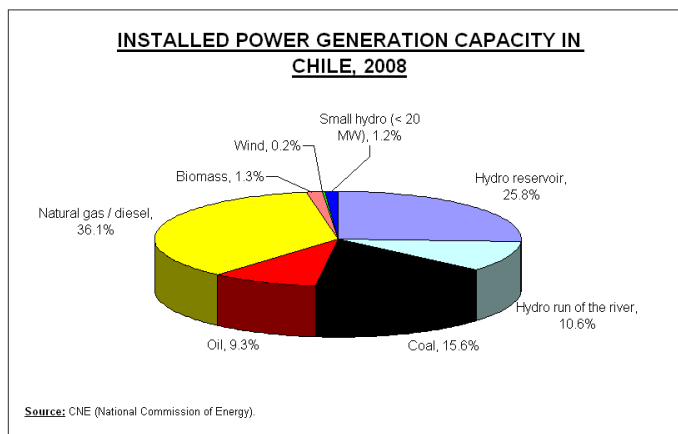

Use of the biomass power generation technology in the Sawmill and Panel board industries in Chile:

The significance of the barriers for biomass power cogeneration can also be verified in the Sawmill and Panel board industries:

- According to Infor (National Forestry Institute)<sup>9</sup>, in 2007 there were 1,310 sawmills in Chile. Of these, only 2 have implemented power cogeneration at a comparable scale as the one considered by the proposed project activity. These two cogeneration power plants are registered CDM project activities. At a lower scale (not comparable to the proposed project activity), the number of sawmills that count with on-site cogeneration in Chile are no more than 2 or 3. In all, the number of sawmills that count with cogeneration technology do not surpass 0.4% of the total existing sawmills in Chile (including registered CDM projects).
- According to Infor<sup>10</sup>, in 2007 there were 21 panel board mills in Chile. Of these, only 2 have integrated cogeneration technology. In both cases, the cogeneration power plants are registered CDM project activities.

Barriers due to the prevailing practice:

As previously mentioned and shown, the utilization of the cogeneration technology in the context of the Sawmill and Panel board industries is marginal (e.g. less than 10% in each case) and clearly departs from the conventional practice in these industries. For that reason, the implementation of this kind of projects face barriers related to the lack of the prevailing practice in these industries (e.g. one of the few of its kind in Chile<sup>11</sup>).

Cultural barriers:

A company's culture in the forestry sector is very much influenced by the commodities: wood-products and pulp, which differs from the culture in the electric power sector. This has the following implications:

<sup>9</sup> See, statistical bulletin N° 123, "La industria del aserrío 2008", page 10, Table 11.

<sup>10</sup> See, statistical bulletin N° 123, "La industria del aserrío 2008", page 10, Table 11.

<sup>11</sup> The only similar projects in Chile are the Trupan biomass power plant and the Nueva Aldea biomass power plant Phase 1. Both power plants (Ref: 0258 and Ref: 0259) are currently registered CDM project activities.

- **Commercial implications:** Unlike forestry products, electric power cannot be stored in order to speculate on price. Power Purchase Agreements require different negotiation skills, which are not part of the competencies of companies that sell commodities such as metals, paper, wood, etc.

In the case of Arauco, this is quite evident, since unlike other power companies in Chile, Arauco only has 30% of its available power capacity engaged in long-term contracts. The usual standard in the Power generation sector in Chile is higher than 60%. This makes Arauco more vulnerable to spot market fluctuations than other power companies.

- **Operational implications:** As mentioned above, cogeneration power plants are far more sophisticated than conventional saturated steam boilers and therefore, require trained and experienced personnel to operate them. This is not valid only for the cogeneration plant operators, but also for the operators of the facilities that use the steam for heating purposes such as sawmills and panel board mills. According to Arauco's experience, people-training is possible, however since there are two types of equipment operating at the same site (e.g. two operational standards coexist at the same site) the operational problems tend to prevail in time. This has been confirmed by external consultants hired by Arauco, who have detected these kinds of problems in other facilities (similar projects currently under the CDM) that have been in operation for some years.

The cultural barriers can be further substantiated by considering that in Chile, there are two big players in the forest industry (e.g. comparable to Arauco) and none of them have developed the biomass power cogeneration technology to the point of becoming a self-power producer in the grid, to date. All the initiatives currently under development by other players in the forest industry (both big and small) consider the use of the CDM. Evidence supporting this argument can be found in the corresponding Annual Reports of these companies and in the Environmental Impact Assessment studies of new cogeneration projects that are publicly available<sup>12</sup>.

#### Regulatory barriers in the Power industry:

The proposed project activity also faces regulatory barriers in the Power industry; some of which are mentioned and explained below:

- Technical barriers faced by self-power producers derived from the Electric law:
  - Article 3-8 of the Technical Norm (RM 40, May, 2005) establishes the frequency range in which all grid-connected power plants (including self-power producers) must operate grid-connected. Unfortunately, this range is set too wide and the norm does not allow self-power producers to disconnect their facilities from the grid until the frequency limits have been exceeded. As a result, self-power producers are not capable of re-establishing their internal power supply and go to island operation in case of extreme frequency fluctuations. This situation exposes the self-power producer production processes to instability and power outages, which translate into additional downtime and start-up operations. This problem has been addressed by external consultants the company has hired (see below).
  - As a result of the low flexibility allowed in the Technical Norm for self-power producers, the configuration of the protection system is crucial to efficiently deal with the fluctuations observed in the grid system. Since there are no other self-power producers than Arauco in Chile, there are no local companies capable of designing a suitable protection system for self-power producers in the country. Furthermore, the protection equipment that is available in the market is designed to react upon an external system failure and not to give the required time to the power producing facility to stabilize its electric system and

---

<sup>12</sup> Please see <<http://www.e-seia.cl/busqueda/buscarProyecto.php>>.

go to island operation. In the case of Arauco, the company has to hire specialized consulting companies abroad and redesign the protection system of its power plants every time it modifies or install a new facility that functions as a self-power producer in the grid.

- Commercial barrier faced by self-power producers derived from the Electric law:
  - Unlike some developed countries in which biomass cogeneration receives favorable treatment and incentives (i.e. Finland, Germany, Sweden, etc.), in Chile, when a cogeneration system is not operational due to maintenance, the developer of cogenerated electricity needs to purchase electricity from the grid. A similar situation happens in case of a technical problem, even if it means stopping the cogeneration plant for just 15 minutes (the minimum period in which the electric distributors measure the peak power consumption). In that case, if the cogeneration facility registers peak power consumption during peak power time, the consuming plant not only has to pay for the electricity (MWh) consumed during this period, but also for the maximum power demand (MW) for the entire billing period. Moreover, while the billing period is monthly, the billing peak demand remains at the maximum demand for 12 months at a time. Thus, if the cogeneration facility is not operational even for a short period of time a year, the industrial customer must pay the demand charge all year long. This is described in CDEC-SIC Dispatch Center rules, Article 118, page 47.
  - Despite the regulatory authorities have recently incorporated some measures<sup>13</sup> to promote the use of non-conventional renewable energy sources, the RM17 of 2004 introduced a new algorithm for the firm power calculation for self-power producing companies. This new algorithm introduced a new penalization factor that lowered the firm power for these power producers, which is not present in the calculation of the firm power of conventional power producers. This measure negatively affects biomass cogeneration facilities such as the Viñales biomass power plant, given that the cogeneration facility falls under this power plant category.
- Other barriers faced by self-power producers derived from the Electric law:
  - The coordination with other generating/distribution/transmission companies also constitutes another barrier for cogeneration power plants such as the Viñales biomass power plant. To be able to sell electric power to the SIC grid and obtain the benefits of a power generating company, Arauco must be part of the CDEC-SIC, the Dispatch Center of the SIC grid. This constitute an operational barrier, since the cogeneration power plant needs to comply with both internal and external energy requirements, compared to pure power plants units in the system, which only need to coordinate with external CDEC instructions. This duality represents a higher operational complexity for the owner of the cogeneration facility, who cannot tune the power plant to exclusively maximize the return on electric power generation assets.

An argument that ratifies and complements the above, refers to the fact that in the SIC system, the non-conventional renewable energy technologies represent less than 5% of the total energy generated in the system. In addition, the electric power industry is highly concentrated, with mainly four power companies concentrating over 60% of the total energy generated in the SIC grid. The low share of non-conventional renewable energy technologies, the high leverage of conventional power generators and the insufficient incentives for renewable sources in the electric law make these barriers structural and relatively permanent for prospective non-conventional energy producers and current players such as Arauco.

---

<sup>13</sup> Short Law I in March 2004 and Short Law II in May 2005.

The coordination with sub-distribution, distribution and transmission companies also becomes more complicated when an industrial facility not only consumes power from the grid but also injects power to the grid. Sometimes the system to which the cogeneration plant must connect is not capable of handling the additional power injected by the power plant. This implies additional investments (reinforcement of sub-transmission lines and new protection systems), which in some occasions can translate into additional (and costly) start-ups delays<sup>14</sup>.

It must be noted that:

- The regulatory barriers outlined above are structural to the country as they equally apply to all kind of companies, regardless of their size and/or previous experience in the field.
- The regulatory barriers cannot be reliably translated into additional cost due to the limited amount of information publicly available. However, the best way to confirm the existence and significance of these barriers is by noting the low development of the cogeneration technology in the Power industry.

Finally, at a more macro level, the current regulatory incentives are not enough to make the use of renewable sources more prevalent in Chile. As a result:

- There is a lack of awareness of the multiple benefits of decentralized energy and therefore, the considerable potential to develop micro power plants in the south of the country remains to be exploited. According to several studies, Chile has considerable electric power generation potential in small-hydraulic, wind and biomass renewable sources.
- Regulations for the electric sector are mostly oriented around centralized large-scale and conventional power generation. This can be substantiated by national statistics. The following graph below shows the new power generation projects that have been approved by the corresponding national authority in 2007:

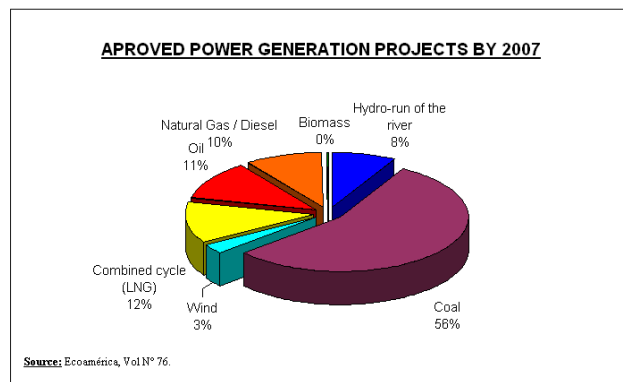

As can be seen, the development of future power generation in Chile is primarily aiming at coal technology in the mid to long term.

- Node price of electricity still does not make the development of non-conventional energy sources economically feasible.

<sup>14</sup> In some cases, these additional costs are hard to anticipate and estimate ex-ante.

- Unlike some more developed countries, the current initiatives that have been implemented by the government to promote non-conventional renewable energy projects do not reflect all the positive externalities related to these technologies.

As a ratification of the above, the Project Proponent would like to note that all (or most) of the barriers presented in this analysis have been also addressed by sectoral studies in Chile carried out by reputed third parties (not the Project Proponent) and explicitly mentioned in articles found in the specialized press:

1. The study: “Evaluaciones del Desempeño Ambiental Chile” (Environmental Performance Review study for Chile)<sup>15</sup>, published by the OECD in 2005, addresses the difficulties faced by renewable power generation projects in Chile. In particular, the study identifies the following barriers:
  - a. Current power prices and policies do not reflect the externality costs caused by more polluting power generation technologies (page 19).
  - b. There is insufficient promotion of low-contaminating power generation technologies (page 33).
  - c. Non-conventional renewable power generation projects must compete in the same terms and conditions as conventional power generation projects (page 63).
2. The study: “Aporte Potencial de Energías Renovables no Convencionales y Eficiencia Energética a la Matriz Eléctrica, 2008 – 2025” (Potential contribution of non-conventional renewable power sources and energy-efficiency to power generation, 2008 – 2025)<sup>16</sup>, June 2008, developed by Universidad de Chile and Universidad Técnica Federico Santa María. Chapter 8 of the study addresses the barriers faced by non-conventional renewable power generation technologies in Chile. In particular, the study mentions the following barriers:
  - a. Poor identification/insufficient information about the available energy resources.
  - b. The geographical situation of Chile (extremely long and narrow country) makes it difficult for mini/micro power plant to interconnect to the SIC (main transmission system).
  - c. Lack of skilled labor, experience and technological development.
  - d. Insufficient incentives.
  - e. Current power prices do not truly reveal the cost of externalities.
  - f. Lack of negotiating capacity with equipment suppliers and long waiting times.
  - g. (For biomass power generation only) The dispersed availability of the biomass residues limits the size biomass power plants. This increases the biomass transportation costs (logistics) and compromises the financial viability of the power generation projects (e.g. the interconnection cost becomes more relevant for a smaller plant).
3. The report: “Chile Energy Policy Review 2009”<sup>17</sup>, October 2009, developed by the International Energy Agency. Chapter 7 is dedicated to renewable energy sources and in page 165, box 7.1 the study explicitly mentions the barriers faced by non-conventional renewable energy sources:
  - a. Lack of information on energy sources.
  - b. Uncertainty in processing permits for new technologies.
  - c. Regulatory barriers: Regulatory framework under development (first drafts started only in 2004).
  - d. Technological barriers: Weak infrastructure (especially access to some resources).
  - e. Investment barriers: Difficulty in accessing credit (capital-intensive with long pay-back periods)<sup>18</sup>.

<sup>15</sup> Available at: <http://www.eclac.org/cgi-bin/getProd.asp?xml=/publicaciones/xml/2/21252/P21252.xml&xsl=/tpl/p9f.xsl&base=/tpl/top-bottom.xsl>

<sup>16</sup> Available at: <http://www.freewebs.com/infoenergia/Informe%20Ejecutivo%20Consolidado.pdf>.

<sup>17</sup> This study is publicly available in the IEA web page.

- f. Technological barriers: Uncertainty regarding technological options, their costs and performance.
  - g. Operational barrier: Need to adapt systems (e.g. the grid) to operate with more intermittent (power) sources.
4. The article “Inversiones por US\$ 3,000 millones en energías verdes estarían en riesgo por rigidez de la ley” (Investments for US\$ 3,000 million would be at risk due to law rigidities), published in November 25<sup>th</sup>, 2009 in “Electricidad Interamericana”, a specialized journal that focuses on the Chilean electric power sector. The article describes that investment in future “green” (non-conventional renewable) power generation projects would be at risk due to rigidities of the Chilean electric law. In particular, the article mentions the following problems/barriers:
- a. Restrictions imposed by the current law to non-conventional renewable power generation technologies make them less competitive compared to other conventional power generation technologies.
  - b. The current law does not provide enough incentives to develop non-conventional renewable power generation technologies in Chile.
  - c. Current power prices and policies do not reflect the externality costs caused by more polluting power generation technologies.
  - d. The presence of commercial restrictions for non-conventional renewable power generation technologies.
  - e. Financing restrictions for non-conventional renewable power generation technologies (see note at the end of this page).

It must be noted that in each of the references presented above, the barriers mentioned are structural and inherently related to the country. The significance of the barriers is not altered or diminished by the type/size of the entity/company behind these kinds of projects. Once again, this can be demonstrated by considering:

1. The low share (3%) of non-conventional renewable power generation in Chile. In particular, for biomass power generation technology, this share is less than 2%.
2. The marginal implementation of the cogeneration technology (clearly less than 10% including CDM projects) in the Sawmill and Panel board industries in Chile.
3. The fact that other relevant players in the forest industry in Chile (comparable to Arauco) have not developed this technology without the aid of the CDM or other type of mechanism. All the initiatives currently underway by these companies (and smaller companies as well), consider some form of carbon finance to overcome the barriers outlined in this section of the document.

Step 2b: Eliminate alternative scenarios which are prevented by the identified barriers.

In this section, the Project Proponent must identify and eliminate the alternative scenarios that are prevented by the identified barriers. This is done in the table below for all the feasible heat generation and biomass use baseline scenarios.

---

<sup>18</sup> This barrier is not really applicable to projects that are financed fully by the project owner and do not need additional credit. Such is the case with the proposed project activity.

Baseline assessment for Power generation:

| Scenario | Barriers that prevent the implementation of the alternative scenarios  | Likely baseline candidate? |
|----------|--|----------------------------|
| P1       | <ul style="list-style-type: none"> <li>Investment barriers.</li> <li>Technological barriers.</li> <li>Barriers due to the prevailing practice.</li> <li>Cultural barriers.</li> <li>Regulatory barriers.</li> </ul>  | No.                        |
| P5       | <ul style="list-style-type: none"> <li>Investment barriers.</li> <li>Technological barriers.</li> <li>Barriers due to the prevailing practice.</li> <li>Cultural barriers.</li> <li>Regulatory barriers.</li> </ul> <p>Regardless of the efficiency of the power plant, the integration of a cogeneration facility to a sawmill is not common practice in Chile.</p> | No.                        |
| P7       | <ul style="list-style-type: none"> <li>This scenario does not face any barriers in the proposed project context.</li> </ul>  | Yes.                       |

Baseline assessment for Heat generation:

| Scenario | Barriers that prevent the implementation of the alternative scenarios   | Likely baseline candidate? |
|----------|---|----------------------------|
| H1       | <ul style="list-style-type: none"> <li>Investment barriers.</li> <li>Technological barriers.</li> <li>Barriers due to the prevailing practice.</li> <li>Cultural barriers.</li> <li>Regulatory barriers.</li> </ul> | No.                        |
| H5       | This scenario does not face any barriers in the proposed project context.   | Yes.                       |

Baseline assessment for Biomass use:

| Scenario | Barriers that prevent the implementation of the alternative scenarios  | Likely baseline candidate?                    |
|----------|--|---|
| B1       | This scenario would not face barriers and is consistent with the common practice in the Sawmill Industry in Chile.   | Yes.  |
| B3       | This scenario would not face barriers and is consistent with the common practice in the Sawmill Industry in Chile.   | Yes.  |
| B4       | This scenario would not face barriers and is consistent with the common practice in the Sawmill Industry in Chile as far as the biomass residues are used for heat generation. | Yes depending on the biomass type (see below) |

According to the above, the likely baseline scenarios for power generation, heat generation and biomass use are the following:

Baseline scenario options for power generation

| Scenarios | Scenario description                       | Associated emissions<br>(1 = lowest) |
|-----------|--|--------------------------------------|
| P7        | The generation of power in the power grid. | 1                                    |

Baseline scenario options for heat generation

| Scenarios | Scenario description  | Associated emissions<br>(1 = lowest, 2 = highest) |
|-----------|---|---|
| H5        | The installation of new plants at the project site different from those installed under the project activity. | 1   |

Baseline scenario options for biomass use

| Scenarios | Scenario description  | Associated emissions<br>(1 = lowest, 3 = highest) |
|-----------|---|---|
| B1        | The biomass residues are dumped or left to decay under mainly aerobic conditions. This applies for example, to dumping and decay of biomass residues on fields. | 1   |
| B3        | The biomass residues are burnt in an uncontrolled manner without utilizing it for energy purposes.  | 2   |
| B4        | The biomass residues are used for power or heat generation at the project site in new and/or existing plants.   | 1   |

According to the above, the project option that would be consistent with the baseline scenarios for power (P7), heat (H5) and biomass use (B1, B3 and B4) would be:

Project option N°1: The installation of a low-pressure boiler on biomass fuels.

**The registration in the VCS would alleviate the identified barriers in the following way:**

The registration of the Viñales biomass power plant project activity in the VCS will report significant benefits to the Viñales sawmill. These benefits will not only circumscribe to the project activity itself, but also to Arauco for overcoming the associated barriers to carry out the proposed project to final completion, and to any other company in Chile who decides to follow Arauco's lead in biomass cogeneration in the future.

The main areas in which the VCS would alleviate the identified barriers are mentioned below:

- The financial benefit derived from the sale of VERs is a strong incentive to develop emission reduction project activities for Arauco. The additional investment related to a biomass electric power generation capacity is about 2 to 3 MMUS\$ per installed MW (depending on the project context), which is significant. The barriers that must be overcome to implement such projects are not minor either. As previously mentioned, they cannot be easily/reliably quantified ex-ante, but they invariably end up translating into additional costs, deteriorating the financial performance of

this type of projects ex-post. In this case, however, the expected revenue that would come from the sale of the VERs would significantly contribute to mitigate these extra risks and costs:

**RELEVANCE OF THE CARBON REVENUE IN THE VIÑALES PROJECT ACTIVITY**

|   |                              | CO <sub>2</sub> price scenarios |            |
|---|------------------------------|---------------------------------|------------|
|   |                              | Low Price                       | High Price |
| Net emission savings  | (tCO <sub>2</sub> eq/yr)     | 154,198                         | 154,198    |
| CO <sub>2</sub> price   | (Euro\$/tCO <sub>2</sub> eq) | 8.0                             | 13         |
| CO <sub>2</sub> price   | (US\$/tCO <sub>2</sub> eq)   | 11.8                            | 19.1       |
| Annual income from carbon sales                               | (KUS\$/yr)                   | 1,817                           | 2,952      |
| Relevant discount rate  | (%)                          | 12%                             | 12%        |
| Net present value of carbon sales                             | (KUS\$)                      | 13,736                          | 22,322     |
| Investment in the Viñales emission reduction project activity | (KUS\$)                      | 82,517                          | 82,517     |
| <b>Relevance of CO<sub>2</sub> revenue</b>                    | <b>(%)</b>                   | <b>17%</b>                      | <b>27%</b> |

**Notes:**

- The investment in the emission reduction project considers the additional investment with respect to the baseline scenario. The baseline scenario consists in the installation of a saturated biomass boiler in the Viñales sawmill.
- The carbon prices considered in this case correspond to the CERs price prospects at the date in which the company decided to go ahead with the Viñales project. The company considered CER prices, since the Viñales project was originally developed as a CDM project activity. Please see section 1.12.5 of this PDD.

As can be seen from the table above, the present value of the carbon sales represents a relevant fraction of the total investment related to the implementation of the proposed VCS project, even in the most conservative price scenario (e.g. 17% of the additional investment related to the proposed project activity). Though this analysis is not possible considering the additional costs associated to each of the identified barriers, it is reasonable to assume that the carbon revenues will clearly help to mitigate the extra costs associated to the barriers in this case.

Furthermore, in this case the carbon proceeds are not only relevant compared to the overall investment, but they also make the proposed project activity financially viable. A detailed financial analysis will be shown in a subsequent section of this document to support this argument.

- The proposed project activity will unquestionably reduce anthropogenic greenhouse emissions by generating electric power via a clean energy source. This is consistent with Arauco's Corporate Policy of Sustainable Development and its current stand of combating Climate Change<sup>19</sup>. Project-based mechanisms such as the VCS have allowed the company to leverage its energy-efficiency policy, by making the big-scale biomass cogeneration technology feasible. As a result, the company has developed this technology in a way no other company has done it in Chile to date.

This has positively contributed to position Arauco as an “environmental friendly” company not only in Chile, but also in the international context. This is relevant to Arauco, since approximately 60% of the company’s consolidated annual sales come from exports to countries that have a high environmental consciousness and care about the use of sustainable technologies. The registration of the proposed project in the VCS will acknowledge Arauco’s effort of using high-end environmental-friendly technology, giving the company a competitive edge in this field.

- The prospects of a project that will generate carbon credits attract financiers who would normally not finance this kind of projects without this additional source of financing. The Project Proponent would like to mention the following evidence that supports this argument:

<sup>19</sup> Arauco's development of GHG emission reduction project activities to combat Climate Change has been mentioned in Arauco's annual reports, sustainability reports, internal company bulletins and several presentations and papers prepared for national and international seminars, discussion tables and industrial guild events.

- Every year, the Chilean Economic Development Agency (CORFO) organizes the International Conference on Renewable Energy Investments and project-based mechanisms<sup>20</sup>. The event provides the opportunity for networking by bringing together private investors, carbon market intermediaries, national project developers, service suppliers, banks, public agents and experts in the renewable energy and Carbon Industry. One of the main aims of this event is to provide the possibility of project proponents of renewable power generation projects to meet potential investors and financiers. The great success and continued growth in importance of this conference over the last years demonstrates that carbon finance attracts potential investors and financiers who would normally not finance this kind of projects.
- In the case of the proposed project activity, from the moment Arauco started the validation of the Viñales biomass power plant expansion project, the company has received several communications from financial institutions who manifested interest in financing the project or provide low-interest financing possibilities to the company in exchange for credits.
- Finally, in the last 20 years, Chile has had a sound macroeconomic management and as a result, it is regarded today as one of the most attractive countries to do business with in Latin America. With the approval of free-trade agreements with USA and the European Union, Chile has a very open and world-integrated economy, which relies heavily on its exports (approximately 40% of its GNP). This makes the Chilean economy very sensitive to external shocks and currency fluctuations. The VCS provides a new/additional hard-currency cash flow stream for the proposed project activity that positively contributes to mitigate the effects of inflation and exchange rate fluctuation.

### **Step 3: Investment analysis**

According to the ACM0006 (Version 12.1.1), if there is only one alternative scenario that is not prevented by any barrier, this alternative is not the project activity and the VCS does alleviate the barriers identified for the proposed project activity, the Project Proponent must proceed to Step 4, the Common Practice Analysis.

In other words, Step 3 the investment analysis cannot be performed in this case, if the Project Proponent is to follow the instructions exactly as in the baseline methodology.

Nevertheless, the Project Proponent would like to present an investment analysis in this case, not as Step 3 of the baseline analysis, but as additional information/evidence that allows to:

1. Substantiate the financial barrier faced by project options that involve cogeneration compared to the business as usual project option in the context of the Viñales project activity (e.g. the Sawmill industry context).
2. Illustrate the relevance of the VCS in the financial performance of the Viñales project activity.

This analysis is shown below and will follow the guidance of Step 3 of the ACM0006 (Version 12.1.1).

### **Analysis method**

Considering that the Viñales biomass power plant project generates financial benefits derived from heat and power purchase avoidance and power sales to the grid, the Project Proponent will carry out an investment comparison analysis in order to determine which option is the most economically/financially convenient.

---

<sup>20</sup> Please see the conference web page at: < <http://www.investchile.com/energyconference/>>.

The Project Proponent will compare different alternatives that involve on-site heat and power generation (a cogeneration plant) with the BAU project option, which only contemplates the generation of heat for the Viñales sawmill. This last project option will be the reference project option.

The Project Proponent will first determine the heat price that would be required to finance the implementation of the reference project option. This will be done by finding the heat price that would make the net present value of the reference project option equal to zero.

This heat price will –then- be used in the financial evaluations of the project alternatives that contemplate the generation of power (cogeneration) in the Viñales sawmill. The Project Proponent will consider two scales and efficiencies of cogeneration plants: the one contemplated by the proposed project activity and a smaller and less efficient cogeneration plant.

If the financial evaluations of the options involving cogeneration turn out to be positive, then it means that on-site heat and power generation (cogeneration) is preferable from a financial standpoint to the option that only implies heat generation. If the opposite happens, then it means that the options involving cogeneration are less convenient from a financial standpoint than the option that just implies heat generation in the Viñales sawmill.

### Financial indicators

The Project Proponent will use the NPV to perform the financial evaluation of the different project options available.

### Main assumptions

The main assumptions used to evaluate all the project options available are presented below:

- The prices for electric power are :
  - Energy: 85 (US\$/MWh) (average for the evaluation horizon).
  - Power: 9 (US\$/KW-month) (node price).
- The price for biomass fuels from industrial operations is 6 (US\$/m<sup>3</sup>st) and 11 (US\$/m<sup>3</sup>st, average) for biomass fuels from forestry operations. This price includes the transportation cost to the Viñales biomass power plant.
- The chosen evaluation horizon for the different project options is from 2008 to 2025.
- The project discount rate used to calculate the NPVs of each option was 12.0%. This is the normal rate used to evaluate the different project options for Arauco in Chile.
- The same assumptions presented above have been used to evaluate all the project options considered in this analysis.

### Financial comparison results

The following summary table presents the financial indicators of each project option considered in the analysis:

| Project options                                      | NPV (In KUS\$) | Comments                            |
|--|----------------|-------------------------------------|
| 1.0 A low-pressure boiler on biomass fuels.          | 0              | Reference scenario, no cogeneration |
| 2.0 A new cogeneration power plant on biomass fuels, | -14,891        | With cogeneration                   |

|  |         |                   |
|--|---------|-------------------|
| implemented with a lower efficiency/scale. |         |                   |
| 3.0 The proposed project activity.         | -23,025 | With cogeneration |

From the table above, it can be seen that neither of the project options that contemplates generation of power (cogeneration) is more attractive than the reference project option, from a financial perspective. In particular, project option N° 3, which corresponds to the proposed project activity, is the most unattractive of all.

The excel spreadsheets with the corresponding financial evaluations are provided as an annexes to this PDD.

### Sensitivity analysis

The tables below show the sensitivity analysis of project options N° 1, N° 2 and N° 3. In this case, the sensitivity analysis was performed considering possible/likely variations in the investment, heat, biomass fuel prices and power. The variations were determined according to the following rationale:

1. Investment: To determine the range in which the considered investment value would most likely fluctuate, the Project Proponent considered the investment behavior (e.g. investment estimation versus real and final investment figure) of similar projects carried out in the recent past by the Project Proponent. From all the projects analyzed, the Project Proponent considered fluctuation of the project that presented the widest investment fluctuation in order to be conservative.
2. Heat: The heat price variation range was determined from the minimum and maximum investment values drawn from the sensitivity analysis above. The rationale is the same as the one described before; a new (higher or lower) investment value for the project option N° 1 would automatically determine a new price for heat that would make the Net Present Value of project option N° 1 equal to zero. In other words, the heat price range is determined by the minimum and maximum investment values for project option N° 1.
3. Biomass: The biomass fuel price ranges were determined by analyzing the historic biomass price behavior during 2006, 2007 and 2008. The information was obtained from the Arauco's biomass procurement department, which supplies Arauco's existing biomass power plants with biomass fuels.
4. Power: Power price in Chile is significantly influenced by hydro power generation, which in turn is greatly determined by the annual hydrology. A dry hydrology means low hydro and high thermal power generation, which leads to high power prices in the system and vice versa. The Project Proponent considered a statistic of the last 49 annual hydrology scenarios to determine the possible power price scenarios. These scenarios contain the most extreme (i.e. driest and wettest) hydrologies that have happened in the last 49 years. The power price was determined by using the PLP simulation software, which is currently used in the CDEC-SIC dispatch center to determine the power price in the SIC interconnected system. The Project Proponent considered 49 different and possible power price scenarios in the sensitivity analysis for all the project alternatives considered.

The results of the sensitivity analysis are shown in the tables below:

**Project option N° 1: A low-pressure boiler on biomass fuels for heat generation**

| Variation in investment<br>(% of variation) | NPV<br>(In US\$ thousands) |
|---|----------------------------|
| -10.0%                                      | 1,479                      |
| <b>0.0%</b>                                 | <b>0</b>                   |
| 25.0%                                       | -3,697                     |

| Variation in power price<br>(% of variation) | NPV<br>(In US\$ thousands) |
|--|----------------------------|
| -52%   | 1,070                      |
| <b>0</b>                                     | <b>0</b>                   |
| 65%  | -1,360                     |

**Note:** The boiler consumes a small amount of power.

| Variation in heat price<br>(% of variation) | NPV<br>(In US\$ thousands) |
|---|----------------------------|
| -7.3%                                       | -1,479                     |
| <b>0.0%</b>                                 | <b>0</b>                   |
| 18.2%                                       | 3,697                      |

| Variation in biomass fuel price<br>(% of variation) | NPV<br>(In US\$ thousands) |
|---|----------------------------|
| -25.0%  | 659                        |
| <b>0.0%</b>   | <b>0</b>                   |
| 25.0%   | -659                       |

**Project option N° 2: A new cogeneration power plant on biomass fuels with lower efficiency/scale**

| Variation in investment<br>(% of variation) | NPV<br>(In US\$ thousands) |
|---|----------------------------|
| -10.0%                                      | -11,164                    |
| <b>0.0%</b>                                 | <b>-14,891</b>             |
| 25.0%                                       | -24,210                    |

| Variation in power price<br>(% of variation) | NPV<br>(In US\$ thousands) |
|--|----------------------------|
| -52%   | -21,632                    |
| <b>0</b>                                     | <b>-14,891</b>             |
| 65%  | -7,169                     |

| Variation in heat price<br>(% of variation) | NPV<br>(In US\$ thousands) |
|---|----------------------------|
| -7.3%                                       | -15,878                    |
| <b>0.0%</b>                                 | <b>-14,891</b>             |
| 18.2%                                       | -12,423                    |

| Variation in biomass fuel price<br>(% of variation) | NPV<br>(In US\$ thousands) |
|---|----------------------------|
| -25.0%  | -11,779                    |
| <b>0.0%</b>   | <b>-14,891</b>             |
| 25.0%   | -18,013                    |

**Project option N° 3: The proposed project activity**

| Variation in investment (% of variation) | NPV (In US\$ thousands) |
|--|-------------------------|
| -10.0%                                   | -15,449                 |
| <b>0.0%</b>                              | <b>-23,025</b>          |
| 25.0%                                    | -41,963                 |

| Variation in power price (% of variation) | NPV (In US\$ thousands) |
|---|-------------------------|
| -52%                                      | -55,146                 |
| <b>0</b>                                  | <b>-23,025</b>          |
| 65%                                       | 12,928                  |

| Variation in heat price (% of variation) | NPV (In US\$ thousands) |
|--|-------------------------|
| -7.3%                                    | -24,009                 |
| <b>0.0%</b>                              | <b>-23,025</b>          |
| 18.2%                                    | -20,564                 |

| Variation in biomass fuel price (% of variation) | NPV (In US\$ thousands) |
|--|-------------------------|
| -25.0%   | -14,125                 |
| <b>0.0%</b>                                      | <b>-23,025</b>          |
| 25.0%  | -31,942                 |

Considering the variation ranges given for investment, heat price, power price and biomass fuel prices, the Project Proponent assessed the probabilities of obtaining a positive Net Present Value for project options N° 1, N° 2 and N° 3. The results of this assessment are provided in the tables below:

**Probability assessment of project option N° 1**

| Variables          | Probability of NPV >=0 | Comments |
|--------------------|------------------------|----------|
| Investment         | 29%                    | Unlikely |
| Power price        | 88%                    | Likely   |
| Heat price         | 71%                    | Likely   |
| Biomass fuel price | 49%                    | Neutral  |

**Probability assessment of project option N° 2**

| Variables   | Probability of NPV >=0 | Comments   |
|-------------|------------------------|--|
| Investment  | 0%                     | The investment would have to be MUS\$ 29,422, which is out of the range considered in this analysis. Unlikely.                 |
| Power price | 0%                     | The power price would have to correspond to an extremely dry hydrology, which has not happened in the last 49 years. Unlikely. |
| Heat price  | 0%                     | The heat price would have to be 19.2 US\$/ton, which is out of the range considered in this analysis. Unlikely.                |

|                    |    |   |
|--------------------|----|---|
| Biomass fuel price | 0% | The biomass fuel prices would have to be negative, which is not only out of the range considered in this analysis, but also impossible. Impossible. |
|--------------------|----|---|

**Probability assessment of project option N° 3**

| Variables          | Probability of NPV >=0 | Comments  |
|--------------------|------------------------|---|
| Investment         | 0%                     | The investment would have to be MUS\$ 69,584, which is out of the range considered in this analysis. Unlikely.                                      |
| Power price        | 6%                     | The power price would have to correspond to an extremely dry hydrology, which has only happened 3 times in the last 49 years. Unlikely.             |
| Heat price         | 0%                     | The heat price would have to be 24.8 US\$/ton, which is out of the range considered in this analysis. Unlikely.                                     |
| Biomass fuel price | 0%                     | The biomass fuel prices would be positive but extremely low. They would still be out of the range considered in the sensibility analysis. Unlikely. |

According to the results above, at the expected heat price level (e.g. the one that makes the net present value of the reference project option equal to zero), project option N° 1 still has a fair chance of becoming financially attractive, considering the variation ranges chosen for the key variables.

For project options N° 2 and N° 3, the scenarios under which they become financially attractive (e.g. present a positive net present value) are extremely unlikely and in some cases, impossible.

In order to complement the analysis above, the Project Proponent performed a sensibility analysis, this time considering an extreme scenario in which project option N° 3 would present a very high<sup>21</sup> plant load factor (88%). The results for this case (only<sup>22</sup>) are presented below

| Project option                    | NPV (In US\$ thousands) | Comments          |
|-----------------------------------|-------------------------|-------------------|
| 3.0 The proposed project activity | -9,916                  | With cogeneration |

The sensitivity analysis is presented in the tables below:

<sup>21</sup> Load factors for biomass power plants connected to the SIC grid normally vary from 60% to 80%.

<sup>22</sup> This analysis was not done for option N° 2, since the plant load factor considered in the previous analysis was already high enough (80%).

**Project option N° 3: The proposed project activity**

| Variation in investment<br>(% of variation) | NPV<br>(In US\$ thousands) |
|---|----------------------------|
| -10.0%                                      | -2,341                     |
| <b>0.0%</b>                                 | <b>-9,916</b>              |
| 25.0%                                       | -28,854                    |

| Variation in power price<br>(% of variation) | NPV<br>(In US\$ thousands) |
|--|----------------------------|
| -52%   | -54,609                    |
| <b>0</b>                                     | <b>-9,916</b>              |
| 65%  | 41,055                     |

| Variation in heat price<br>(% of variation) | NPV<br>(In US\$ thousands) |
|---|----------------------------|
| -7.3%                                       | -10,900                    |
| <b>0.0%</b>                                 | <b>-9,916</b>              |
| 18.2%                                       | -7,455                     |

| Variation in biomass fuel price<br>(% of variation) | NPV<br>(In US\$ thousands) |
|---|----------------------------|
| -25.0%  | 3,256                      |
| <b>0.0%</b>   | <b>-9,916</b>              |
| 25.0%   | -23,103                    |

**Probability assessment of project option N° 3**

| Variables          | Probability of NPV >=0 | Comments  |
|--------------------|------------------------|---|
| Investment         | 0%                     | The investment would have to be MUS\$ 86,884, which is out of the range considered in this analysis. Unlikely.                          |
| Power price        | 6%                     | The power price would have to correspond to an extremely dry hydrology, which has only happened 3 times in the last 49 years. Unlikely. |
| Heat price         | 0%                     | The heat price would have to be 15.9 US\$/ton, which is out of the range considered in this analysis. Unlikely.                         |
| Biomass fuel price | 12%                    | The biomass fuel prices would be positive, but still very low. Unlikely.  |

Considering this new analysis for project option N° 3 (the proposed project activity), it can be reasonably concluded that even under a very favorable scenario (very high load factor), the circumstances under which this project option would present a positive NPV are extremely unlikely and therefore, the additional investment related to power generation (cogeneration) is not justified from a financial perspective.

From the sensibility analysis performed above, it is clear that both project options N° 2 and N° 3 are less attractive from a financial standpoint than project option N° 1, which is the reference scenario. In this context, it is much more convenient to invest in a conventional saturated steam boiler for the Viñales sawmill than in a cogeneration power plant.

The conclusions of this analysis are likely to hold considering the future perspectives of the variables considered relevant for the sensitivity analysis:

1. Investment costs are likely to increase slightly or maintain the current level, given the high demand of boilers and power-related equipment worldwide<sup>23</sup>.
2. Power prices in Chile are likely to maintain their high current level for the next five years as a result of the low investment in power generation in the past 10 years. Prices will probably bounce back when the new power plants (mainly coal plants) enter in operation.
3. Since heat price is directly related to investment cost, it will most likely follow the investment cost behavior.
4. Since biomass fuel prices are greatly influenced by fuel prices (transport) and power prices (power demand), it will most likely follow the power price behavior.

Finally, it must also be noted that project option N° 3 could become financially attractive if carbon proceeds were included. The table below shows the NPV of project option N° 3:

| <b>Project option N° 3: The proposed project activity</b>   | <b>NPV<br/>In US\$ thousands</b> |
|---|----------------------------------|
| Net present value with carbon proceeds (normal load factor) | 4,870                            |
| Net present value with carbon proceeds (high load factor)   | 17,979                           |

**Note:** Carbon prices were considered at the date of decision.

Without carbon proceeds, the proposed project activity is definitely not likely to become financially attractive. As a result, it can reasonably be concluded that:

1. The financial barrier is significant in this case, and clearly prevents the proposed project activity from happening.
2. The aid of the VCS clearly contributes to alleviate the financial barrier in this particular case.

According to the analysis above, the baseline project option would correspond to the installation of a new heat generation facility in the Viñales sawmill (no cogeneration).

To complement the analysis above, the Project Proponent would like to present information that further ratifies and substantiates the selection of the baseline scenario for power, heat and biomass use. This information is provided in the tables below:

### Electric power generation baseline

| <b>Industry</b> | <b>Current practice in Chile</b>                                   | <b>Documentation/reference</b>  | <b>Description of the technology used in the absence of the proposed project activity</b> |
|-----------------|--|---|---|
| Electric power  | <ul style="list-style-type: none"> <li>• Electric power</li> </ul> | <ul style="list-style-type: none"> <li>• CDEC SIC and CDEC-SING Dispatch Centers annual generation statistics.</li> </ul> | <ul style="list-style-type: none"> <li>• The additional power generated</li> </ul>        |

<sup>23</sup> This is mainly due to the high demand of steel and other raw materials from China and India, which have been growing approximately at 10% during the last years.

|   |  |  |  |
|---|--|--|--|
| <p>generation industry</p>                | <p>generation through conventional technologies</p> <ul style="list-style-type: none"> <li>• Biomass co-generated power accounts for merely 1 to 2 % of the total energy generated into the grid for external consumption in the country.</li> </ul>                         |  | <p>by the Viñales biomass power plant would be generated in other conventional power plants connected to the SIC grid. The power generation technologies in the SIC grid include mainly: hydro, combined cycle, open cycle and conventional coal.</p>  |
| <p>Sawmill and Panel board industries</p> | <ul style="list-style-type: none"> <li>• Sawmills and Panel board mills do not integrate cogeneration power plants to their facilities and therefore do not contemplate the generation of power on-site.</li> </ul>  | <ul style="list-style-type: none"> <li>• Baseline solution design for the Viñales sawmill.</li> <li>• Other industry players company information in their web pages, Annual Reports and Sustainability Reports.</li> </ul>   | <ul style="list-style-type: none"> <li>• Conventional low-pressure boiler for heat generation. This technology used under the chosen baseline scenario is the one normally used in the Sawmill and Panel board mills in Chile.</li> <li>• For more details, please see section A.4.3 of this PDD.</li> </ul> |
| <p>Pulp industry</p>                      | <ul style="list-style-type: none"> <li>• Pulp mills in Chile tend to be (not all currently are) self-sufficient in electric power generation. Modern pulp mills achieve this by burning black liquor in their recovery boilers.</li> <li>• It is also part of the</li> </ul> | <ul style="list-style-type: none"> <li>• AF-Celpap baseline mill design for several Arauco pulp mill projects.</li> <li>• Pulp industry publications such as ATCP Chile.</li> <li>• DIA and EIA studies of pulp mills in Chile by other industry players. SEIA and CONAMA web pages.</li> <li>• Other industry player's company information in their web pages. Other industry player's Annual Reports and Sustainability Reports.</li> <li>• International documentation on best practices in the pulp industry: Please see table 2.46 of the BREF document (the "European IPPC Bureau. 2001. Integrated Pollution Prevention and Control (IPPC), Reference Document on Best Available Techniques in the Pulp and Paper Industry, Seville, Spain, p 111.". The link: <a href="http://eippcb.jrc.ec.europa.eu/pages/FActivities.htm">http://eippcb.jrc.ec.europa.eu/pages/FActivities.htm</a>).</li> </ul> | <ul style="list-style-type: none"> <li>• Conventional low-pressure boiler for heat generation running on biomass or fossil fuels. No cogeneration.</li> </ul>  |

|  |  |  |  |
|--|--|--|--|
|  | <p>business-as-usual practice to have a small boiler for heat generation (e.g. to aid start-up operations). These boilers usually run on biomass fuels (from the debarking section of the mill) or fossil fuels.</p> |  |  |
|--|--|--|--|

**Heat generation baseline**

In the Sawmill industry, heat generation using biomass residues is a common practice. As a result, the proposed project activity does not claim emission reductions due to this source.

| Industry               | Current practice in Chile  | Documentation/reference   | Description of the technology used in the absence of the proposed project activity  |
|------------------------|--|---|---|
| Sawmill industry       | <ul style="list-style-type: none"> <li>Use biomass residues as fuel for heat generation (mainly wood drying).</li> </ul>             | <ul style="list-style-type: none"> <li>Company information of other relevant Sawmill players in Chile.</li> <li>Forest industry publications such as Lignum, Ecoamérica and Infor reports.</li> </ul>   | <ul style="list-style-type: none"> <li>Conventional low pressure boiler on biomass residues for heat generation. No cogeneration.</li> </ul>                |
| Panel board industries | <ul style="list-style-type: none"> <li>Use biomass residues as fuel for heat generation (presses and drying).</li> </ul>             | <ul style="list-style-type: none"> <li>Company information of other relevant Panel board players in Chile.</li> <li>Forest industry publications such as Lignum, Ecoamérica and Infor reports.</li> </ul>   | <ul style="list-style-type: none"> <li>Conventional low pressure boiler on biomass residues for heat generation. No cogeneration.</li> </ul>                |
| Pulp industry          | <ul style="list-style-type: none"> <li>Pulp mills in Chile tend to be (not all currently are) self-sufficient in electric</li> </ul> | <ul style="list-style-type: none"> <li>AF-Celpap baseline mill design for several Arauco pulp mill projects.</li> <li>Pulp industry publications such as ATCP Chile.</li> <li>DIA and EIA studies of pulp mills in Chile by other industry players. SEIA and CONAMA web pages.</li> <li>Other industry player's company information in their web pages. Other industry player's Annual</li> </ul> | <ul style="list-style-type: none"> <li>Conventional low-pressure boiler for heat generation running on biomass or fossil fuels. No cogeneration.</li> </ul> |

|  |   |  |  |
|--|---|--|--|
|  | <p>power generation. Modern pulp mills achieve this by burning black liquor in their recovery boilers.</p> <ul style="list-style-type: none"> <li>It is also part of the business-as-usual practice to have a small boiler for heat generation (e.g. to aid start-up operations). These boilers usually run on biomass fuels (from the debarking section of the mill) or fossil fuels.</li> </ul> | <p>Reports and Sustainability Reports.</p> <ul style="list-style-type: none"> <li>International documentation on best practices in the pulp industry: Please see table 2.46 of the BREF document (the "European IPPC Bureau. 2001. Integrated Pollution Prevention and Control (IPPC), Reference Document on Best Available Techniques in the Pulp and Paper Industry, Seville, Spain, p 111.". The link: <a href="http://eippcb.jrc.ec.europa.eu/pages/FActivities.htm">http://eippcb.jrc.ec.europa.eu/pages/FActivities.htm</a>).</li> </ul> |  |
|--|---|--|--|

**Unused biomass baseline**

The following table establishes the baseline of the additional biomass that will be burned in the new Viñales biomass power plant as a result of implementing the project activity. The baseline is established using a per-industry analysis.

| Industry                           | Current practice in Chile  | Documentation/reference  | Description of the technology used in the absence of the proposed project activity   |
|------------------------------------|--|--|--|
| Sawmill and Panel board industries | <ul style="list-style-type: none"> <li>Use part of the biomass residues generated internally as fuels to generate heat (i.e. for wood drying), sell the remaining</li> </ul> | <ul style="list-style-type: none"> <li>Sawmill and Panel board industries information in Chile.</li> <li>Forest industry publications such as Lignum, Ecoamérica and Infor reports.</li> </ul> | <ul style="list-style-type: none"> <li>The additional biomass consumed by the proposed project activity would most likely be left in piles for natural decay. In some particular cases,</li> </ul> |

|                 |  |  |   |
|-----------------|--|--|---|
|                 | residues if possible. Still, a considerable surplus of biomass remains unused in the region, which is dumped or burned in an uncontrolled manner.  |  | the biomass would be burned in the open-air in an uncontrolled manner.  |
| Forest industry | <ul style="list-style-type: none"> <li>Residues from harvesting, pruning and thinning operations are mostly left in piles to natural decay. In some particular cases the residues are burned in an uncontrolled manner.</li> </ul>   | <ul style="list-style-type: none"> <li>Conventional forest management practices of Arauco and other forest companies of comparable size in Chile.</li> <li>Forest industry publications such as Lignum, Ecoamérica and Infor reports.</li> </ul>   | <ul style="list-style-type: none"> <li>The additional biomass consumed by the proposed project activity would most likely be left in piles for natural decay. In some particular cases the residues would be burned in an uncontrolled manner.</li> </ul> |
| Pulp industry   | <ul style="list-style-type: none"> <li>Pulp mills in Chile tend to be (not all currently are) self-sufficient in electric power generation. Modern pulp mills achieve this by burning black liquor in their recovery boilers.</li> <li>It is also part of the business-as-usual practice to have a small boiler for heat generation (e.g. to aid start-up</li> </ul> | <ul style="list-style-type: none"> <li>AF-Celpap baseline mill design for several Arauco pulp mill projects.</li> <li>Pulp industry publications such as ATCP Chile.</li> <li>DIA and EIA studies of pulp mills in Chile by other industry players. SEIA and CONAMA web pages.</li> <li>Other industry player's company information in their web pages. Other industry player's Annual Reports and Sustainability Reports.</li> <li>International documentation on best practices in the pulp industry: Please see table 2.46 of the BREF document (the "European IPPC Bureau. 2001. Integrated Pollution Prevention and Control (IPPC), Reference Document on Best Available Techniques in the Pulp and Paper Industry, Seville, Spain, p 111.". The link: <a href="http://eippcb.jrc.ec.europa.eu/pages/FActivities.htm">http://eippcb.jrc.ec.europa.eu/pages/FActivities.htm</a>).</li> </ul> | <ul style="list-style-type: none"> <li>The additional biomass consumed by the proposed project activity would most likely be left in piles for natural decay. In some particular cases the residues would be burned in an uncontrolled manner.</li> </ul> |

|  |  |  |  |
|--|--|--|--|
|  | <p>operations).<br/>These boilers usually run on biomass fuels (from the debarking section of the mill) or fossil fuels.</p> |  |  |
|--|--|--|--|

## 2.5 Additionality

Considering that the previous section of the PDD addressed steps 1 to 3 (more related to the baseline), this section will go through Step 4, which is the final step in the baseline methodology to establish the additionality of the proposed project activity.

### **Step 4: Common practice analysis.**

#### **4.1 Other activities similar to the proposed project activity in Chile**

##### **4.1.1 Arauco initiatives:**

Arauco is the only company to have developed big-scale biomass cogeneration technology to the point of becoming a net power exporter to the grid in Chile. It is also the only company to have integrated the cogeneration technology to industrial facilities, which normally do not use this technology to generate power.

Arauco has two biomass cogeneration power plants similar to the proposed project activity: The Trupan biomass power plant and the Nueva Aldea Phase 1 biomass power plant. Both projects were developed as part of Arauco’s initiative in the CDM and are currently registered CDM project activities:

- “Trupan Biomass Power Plant in Chile”, Ref: 0259
- “Nueva Aldea Biomass Power Plant Phase 1”, Ref: 0258

##### **4.1.2 Other company’s initiatives:**

A relevant competitor in the pulp industry in Chile installed a biomass (bark) power boiler (150 ton steam/hr at 60 bar) inside one of its pulp mills. This initiative was mainly oriented towards the generation of steam for a future wood products mill that will be installed near the pulp mill area. It will also provide additional steam to increase the electric power generation capacity inside the pulp mill to make it (and other company’s interconnected pulp mills in the region) self-sufficient in electric power generation.

Today it is a common practice in the pulp industry not to rely in external electric power sources, but to generate all power internally. Older pulp mills were less energy efficient (both in energy consumption and generation capacity) so they were not necessarily self-sufficient in electric power generation.

The rest of the biomass cogeneration initiatives in Chile are definitely not comparable to the proposed project activity, since they are significantly smaller scale than the Viñales biomass power plant (i.e. <50 tvap/hr, saturated or near saturated steam at 45 bar, <10 MW, etc.).

#### 4.2. Analysis of similar options observed in Chile

Other biomass cogeneration initiatives have been presented and discussed in the preceding section. From the Project Proponent’s point of view, these initiatives present clear differences that make the proposed project activity particular and unique in its type. However, even in the case these cogeneration initiatives were considered similar to the proposed project activity, biomass cogeneration for additional power generation would still not be the common practice in any of the industries in which the proposed project activity is related to:

**Electric power industry:** The following table shows the biomass power generation situation in the SIC grid and in Chile:

|  |          | 2002   | 2003   | 2004   | 2005   | 2006   | 2007   | 2008   |
|--|----------|--------|--------|--------|--------|--------|--------|--------|
| Total power generation in Chile                            | (GWh)    | 42,636 | 45,409 | 48,970 | 50,937 | 53,916 | 56,279 | 56,679 |
| Total biomass power generation in Chile                    | (GWh)    | 374    | 429    | 649    | 516    | 571    | 744    | 884    |
| Biomass power generation / total power generation in Chile | (%)      | 0.9%   | 0.9%   | 1.3%   | 1.0%   | 1.1%   | 1.3%   | 1.6%   |
| Nº of biomass power plants in the SIC (and in Chile)       | (Number) | 4      | 5      | 7      | 8      | 8      | 10     | 10     |
| Total Number of power plants in the SIC                    | (Number) | 54     | 56     | 60     | 67     | 70     | 90     | 106    |

**Sources:** CNE, <<http://www.cne.cl/>>, CDEC-SIC.

**Note:** Biomass power generation includes all types of biomass. 2008 includes 4 Arauco biomass power generation projects registered under the CDM.

From the table above, it is possible to see the extremely low share of biomass-generated power compared to the total power generation in Chile. Furthermore, the table above does not consider some still non-registered CDM projects from Arauco. In other words, in the last years there has not been any other new biomass power plant added to the SIC, other than the ones built by (mostly) Arauco under the CDM.

**Sawmill industry:** As mentioned in the preceding section of this PDD, in 2007 there were 1,310 sawmills in Chile. According to Infor, the typical process flow chart of a well-established sawmill includes an artificial drying stage of the sawn timber. It must be mentioned that in 2007 stage was applied to 54.2% of the total sawn timber produced in Chile. In addition, only the “Very big scale” sawmills are capable of implementing this process and they do it in 64.6% of their total output.

Artificial drying is accomplished using two techniques. The first one uses traditional drying chambers in which the wood is dried at approximately 70°C and ambient pressure. The energy required to heat the chamber is normally generated by a saturated steam boiler fuelled by the wood residues from the same saw-milling process. The second consists in vacuum drying, in which the wood is dried in a vacuum chamber at ambient temperature. This system is more efficient than the previous one, but implies the consumption of electric power, which is supplied from the grid. On-site electric power cogeneration from biomass sources is not considered (even hardly mentioned) as normal practice in this industry<sup>24</sup>.

**Other comparable industries: Plywood, MDF and other wood panel board industries:** Like sawmills, plywood mills and other wood panel producing mills are not designed to operate with high pressure steam, so on-site power generation is not considered a normal practice either. In Chile there are two cogeneration initiatives comparable (in scope and scale) to the proposed project activity: the Trupan and the Nueva Aldea Phase 1 cogeneration power plants, owned by Arauco. As mentioned before, both initiatives have been implemented under the CDM.

**Pulp industry:** Though cogeneration is widely used in the Pulp industry and part of the business as usual practice, only modern pulp mills tend to be self-sufficient in thermal and electric power generation. In these mills, all internal thermal and electric power requirements are served by burning black liquor in the

<sup>24</sup> Refer to “Boletín Estadístico 123”, “La Industria del Aserrío, Chile 2008”, that provides a description of the Sawmill industry in Chile.

recovery boiler (not biomass from industrial and/or forestry operations), which is part of the Kraft process. In some cases, a small (50 to 80 ton/hr) biomass (bark) power boiler to supplement internal thermal and electric power generation is also considered a normal practice. However, it is not the common practice in Chile (or in the world) that a pulp mill becomes a net electric power exporter and operates as a power plant in the grid to which it is connected. Even today, there are examples of pulp mills recently built in Chile that are not self-sufficient in electric power generation, and must rely on power from the grid to serve their internal power requirements on a normal basis.

According to the analysis above, the following conclusions can be drawn:

1. The Viñales biomass power plant project is one of the few of its type in Chile.
2. Biomass cogeneration projects in the Sawmill and Panel board industries are not observed as common initiatives.
3. Biomass cogeneration projects in the Power industry are equally unique and therefore not observed as common initiatives either.
4. The utilization of the biomass cogeneration technology in the Pulp industry context is normally used. However, this technology is used for making the pulp mill facility self-sufficient in heat and electric power generation and not for making the facility generate surplus power to the grid. In addition, there are sufficient differences in scale and context to make the proposed project activity not comparable to power generation initiatives in the Pulp industry.

For these reasons, the Viñales biomass power plant project activity is not considered to be part of the common practice in the relevant (and comparable) industry (ies) in Chile and therefore, considered additional from a common practice analysis perspective.

## 2.6 Methodology Deviations

There are methodological deviations related to the monitoring of some parameters outlined in the Monitoring Methodology applicable in this case. These deviations are minor and are explicitly mentioned in the “Calculation” section of each of the corresponding parameters.

Biomass residue calculation method: As presented in the “Monitoring” section of this document, most of the biomass consumed under the project activity will be directly measured. However, approximately 10% of the total biomass consumed in the project plant will have to be calculated using indirect measurements. These biomass residues are generated inside the Viñales site, in the Sawmill and the Remanufacture plants. These residues are calculated, since they are sent directly to the Viñales power boiler via a pneumatic transportation system, making direct measurement methods not practical. The method basically consists in calculating the wood mass difference between the wood entering and exiting the sawmill and remanufacture plants. The calculation methods for both cases, the sawmill and remanufacture plants are fully explained in Annex 1 of this document.

Heat generator baseline efficiency: According to the “Tool to determine the baseline efficiency of thermal or electric energy generation systems” the Project Proponent can use a default factor of 100% for the efficiency of the boiler that would be used in the baseline scenario. However, in the case of the Viñales project activity, such value does not lead to a conservative emission reduction calculation.

The reason for this is because the higher the efficiency of the heat generator in the baseline scenario (i.e. a boiler generating saturated steam for heating purposes), the lower the amount of biomass residues attributed to heat generation. The difference between the total biomass residues consumption under the project scenario (i.e. actual biomass consumption) and this hypothetical biomass consumption for heat generation in the baseline is the biomass related to power generation under the project scenario.

Consequently, the lower the biomass consumption associated to heat generation, the higher the biomass amount related to power generation. The higher the biomass associated to power generation, the higher the baseline emissions due to avoided uncontrolled burning and/or decomposition of biomass residues in the open air. As a result, a lower efficiency of the heat generator that would be installed in the baseline scenario leads to lower baseline emissions due to avoided uncontrolled burning and/or decomposition of biomass residues in the open air, which is conservative and vice-versa.

As a result, the Project Proponent did not use the 100% heat generator efficiency which according to the above clearly leads to a non-conservative emission reduction calculation, but rather proposed a lower and more realistic efficiency of 85% for the biomass boiler that would have been used under the baseline scenario. This particular value is justified because of:

- Was proposed by Andritz and Metso, two reputable global suppliers of technology and services in the process industries, including mining, construction, recycling, pulp and paper, power and oil and gas.
- The Executive Board of the Clean Development Mechanism has approved the same efficiency value in the past for other similar emission reduction projects in Chile.

Calculation of the auxiliary power consumption of the Viñales biomass power plant: According to the ACM0006 (Version 12.1.1), the auxiliary power consumption must be measured and deducted from the gross power generation of the plant to carry out the emission reduction calculation. In the case of the proposed project activity there is a small fraction (< 10%) of the auxiliary power consumption that will be conservatively estimated, considering the maximum possible electric power consumption that the corresponding equipment may have during a year. Such estimation is done using the maximum theoretical power consumption of each of the relevant equipment and multiplying them by 8,760 hours, which is the total (and maximum) amount of hours in a year. This estimation provides the maximum possible power consumption of the relevant equipment in a year, hence providing a very conservative estimate for the emission reduction calculation of the project activity. The full explanation of the calculation is provided in the “Monitored parameters” section of this document.

### 3 QUANTIFICATION OF GHG EMISSION REDUCTIONS AND REMOVALS

#### 3.1 Baseline Emissions

Baseline emissions are calculated based on the most plausible baseline scenario identified in this document. This calculation is performed taking into account how power and heat would be generated and how the biomass residues would be used in the absence of the proposed project activity.

According to the ACM0006 (Version 12.1.1), baseline emissions are calculated using equation 2 as follows:

$$BE_y = EL_{BL,GR,y} * EF_{EG,GR,y} + \sum_f FF_{BL,HG,y,f} * EF_{FF,y,f} + EL_{BL,FF/GR,y} * \min(EF_{EG,GR,y}, EF_{EG,FF,y}) + BE_{BR,y}$$

Where:

|                     |  |
|---------------------|--|
| $BE_y$ =            | Baseline emissions in year y (tCO <sub>2</sub> /yr).                                     |
| $EL_{BL,GR,y}$ =    | Baseline minimum electricity generation in the grid in year y (MWh/yr).                  |
| $EF_{EG,GR,y}$ =    | Grid emission factor in year y (tCO <sub>2</sub> /MWh).                                  |
| $FF_{BL,HG,y,f}$ =  | Baseline fossil fuel demand for process heat in year y (GJ/yr).                          |
| $EF_{FF,y,f}$ =     | CO <sub>2</sub> emission factor for fossil fuel type f in year y (tCO <sub>2</sub> /GJ). |
| $EL_{BL,FF/GR,y}$ = | Baseline uncertain electricity generation in the grid or on-site in year y (MWh/yr).     |

|                  |   |
|------------------|---|
| $EF_{EG,FF,y}$ = | CO <sub>2</sub> emission factor for electricity generation with fossil fuels at the project site in the baseline in year y (tCO <sub>2</sub> /MWh). |
| $BE_{BR,y}$ =    | Baseline emissions due to disposal of biomass residues in year y (tCO <sub>2</sub> e/yr).   |
| y =              | Year of the crediting period.   |
| f =              | Fossil fuel type.   |

The Project Proponent will use the algorithm presented in page 23 of the ACM0006 (Version 12.1.1) to calculate the baseline emissions. The algorithm has the following steps:

Step 1: Determine the biomass availability, generation and capacity constraints, efficiencies and power emission factors.

Step 2: Determine the minimum baseline electricity generation in the grid;

Step 3: Determine the baseline biomass-based heat and power generation;

Step 4: Determine the baseline demand for fossil fuels to meet the balance of process heat and the corresponding electricity generation;

Step 5: Determine the baseline emissions due to uncontrolled burning or decay of biomass residues;

Step 6: Calculate baseline emissions.

In the following section, the Project Proponent will state the methodological choices and equations that will be used in the calculation of the baseline emissions for the proposed project activity.

**Step 1: Determine biomass availability, generation and capacity constraints, efficiencies and power emission factors in the baseline**

**Step 1.1: Determine total baseline process heat generation**

The amount of process heat that would be generated in the baseline in year y ( $HC_{BL,y}$ ) will be determined as the difference of the enthalpy of the process heat (steam) supplied to process heat loads in the project activity minus the enthalpy of the feed water, the boiler blow-down and any condensate return to the heat generator(s).

The respective enthalpies will be determined based on the mass flows, temperatures and, in case of superheated steam, the pressure. Steam tables and/or appropriate thermodynamic equations will be used to calculate the enthalpy as a function of temperature and pressure. The process heat will be calculated net of any parasitic heat used for drying of the biomass residues.

**Step 1.2: Determine total baseline electricity generation**

The amount of electricity that would be generated in the baseline in year y is calculated using equation 3 as follows:

$$EL_{BL,y} = EL_{PJ,gross,y} + EL_{PJ,imp,y} - EL_{PJ,aux,y}$$

Where:

$EL_{BL,y}$  = Baseline emissions generation in year y (MWh/yr).

- EL<sub>PJ, gross, y</sub> = Gross quantity of electricity generated in all power plants which are located at the project site and included in the project boundary in year y (MWh/yr).
- EL<sub>PJ, imp, y</sub> = Project electricity imports from the grid in year y (MWh/yr).
- EL<sub>PJ, aux, y</sub> = Total auxiliary electricity consumption required for the operation of the power plants at the project site in year y (MWh/yr).
- y = Year of the crediting period.

In the case of the proposed project activity, EL<sub>PJ, aux, y</sub> will include all electricity required for the operation of:

- Power boiler
- Cooling towers
- Turbine plant
- Water sourcing and treatment
- Biomass handling

The rest of the power consumption in the Viñales site is related to the sawmill.

**Step 1.3: Determine the baseline capacity of electricity generation**

The total capacity of electricity generation available in the baseline will be calculated using equation 4 below:

$$CAP_{EG, total, y} = LOC_y * \left[ \sum_i (CAP_{EG, CG, i} * LFC_{EG, CG, i}) + \sum_j (CAP_{EG, PO, j} * LFC_{EG, PO, j}) \right]$$

Where:

- CAP<sub>EG, total, y</sub> = Baseline electricity generation capacity in year y (MWh/yr).
- CAP<sub>EG, CG, i</sub> = Baseline electricity generation capacity of heat engine i (MW).
- CAP<sub>EG, PO, j</sub> = Baseline electricity generation capacity of heat engine j (MW).
- LFC<sub>EG, CG, i</sub> = Baseline load factor of heat engine i (ratio).
- LFC<sub>EG, PO, j</sub> = Baseline load factor of heat engine j (ratio).
- LOC<sub>y</sub> = Length of the operational campaign in year y (hour).
- i = Cogeneration-type heat engine in the baseline scenario.
- j = Power-only-type heat engine in the baseline scenario.
- y = Year of the crediting period.

In the case of the proposed project activity, there would be no on-site power generation in the baseline as all the power would be generated in grid-connected power plants.

**Step 1.4: Determine the baseline availability of biomass residues**

In the case of the proposed project activity, the biomass type that would be used for heat generation in the Viñales sawmill would be:

- Sawdust and bark from industrial operations, generated on-site.

Note that all the biomass residues under this category would be burned in a saturated-steam heat generator only to the extent of generating process heat for the Viñales sawmill. Any surplus of biomass residues under this category would be discarded in a baseline scenario.

**Step 1.5: Determine the efficiencies of heat generators and efficiencies and heat-to-power ratio of heat engines**

1.5.1 Efficiencies of heat generators and heat engines

Considering that the proposed project activity is a greenfield power generation project (e.g. no previous operational history), the Project Proponent will choose:

Option 1: Default values. Use option F in the latest approved version of the “Tool to determine the baseline efficiency of thermal or electric energy generation systems” Since in this case a suitable default value is not provided for the technology used in the project case, the Project Proponent will propose a conservative estimate for the baseline efficiency of the heat generator under the baseline scenario.

**Step 1.6: Determine the emission factor of on-site electricity generation with fossil fuels**

In the case of the proposed project, there is no fossil fuel based power generation identified as part of the baseline scenario. As a result the Project Proponent will do:

$$EF_{EG,FF,y} = EF_{EG,GR,y}$$

Where:

$EF_{EG,FF,y}$  = CO<sub>2</sub> emission factor for electricity generation with fossil fuels at the project site in the baseline in year y (tCO<sub>2</sub>/MWh).

$EF_{EG,GR,y}$  = CO<sub>2</sub> emission factor of the fossil fuel type that would be used for power generation at the project site in the baseline (tCO<sub>2</sub>/MWh).

**Step 1.7: Determination of the emission factor of grid electricity generation**

According to the ACM0006 (Version 12.1.1), the Project Proponent will determine the parameter  $EF_{EG,GR,y}$  as the combined margin CO<sub>2</sub> emission factor for grid to which the project activity is connected in year y. The combined margin will be calculated using the latest approved version of the “Tool to calculate the emission factor for an electricity system”.

**Determination of  $EF_{EG,GR,y}$**

According to the latest version of the “Tool to calculate the emission factor for an electricity system (Version 03.0.0)” the following steps must be followed:

Step 1: Identify the relevant electricity system.

The tool establishes that the Project Proponent should use the electricity system to which the proposed project activity is connected to, provided there are no significant transmission constraints.

The proposed project activity is connected to the Central Interconnected System of Chile (SIC). The SIC is composed by the transmission lines and the interconnected power plants that operate from Rada de Paposo in the north (II Region), to Isla Grande de Chiloé in the south (X Region). The SIC is the largest of the four transmission systems in Chile, accounting for about 75% of the power generation capacity of the country and supplying to approximately 93% of the total population. The SIC has no interconnection with any other transmission system in Chile or in the region.

According to the criteria indicated in the tool for establishing the presence of significant transmission constraints, the Project Proponent verified that none of the conditions are satisfied in the case of the SIC system. In particular, the Project Proponent verified that:

1. Prices in the SIC do not differ more than 5% during 60% or more of the year and
2. There is no transmission line in the SIC that is operated at 90% or more during 90% or more of the year.

The corresponding assessment for the SIC grid was done for the year 2008. The study will be provided as supporting evidence during the validation of the proposed project activity.

The absence of significant transmission constraints in the transmission systems can be further substantiated by the Short Law N° 1 (March, 2004). This law mandates transmission companies to assess their transmission systems every 4 years and make all the necessary investments in order to secure the quality and safety of the transmission service.

Step 2: Choose whether to include off-grid power plants in the project electricity system (optional).

Not applicable in this case.

Step 3: Select a method to determine the operating margin (OM).

Considering the characteristics of the SIC system (e.g. low-cost/must run power generation) and availability of information, the Project Proponent will choose option b) to calculate the Operating Margin (OM).

The Simple Adjusted OM method requires identifying low cost/must run resources (*k*) from other power sources (*m*):

$$EF_{grid,OM-adj,y} = (1 - \lambda_y) \cdot \frac{\sum_m EG_{m,y} \cdot EF_{EL,m,y}}{\sum_m EG_{m,y}} + \lambda_y \cdot \frac{\sum_k EG_{k,y} \cdot EF_{EL,k,y}}{\sum_k EG_{k,y}}$$

Where:

- $EF_{grid,OM-adj,y}$  = Simple adjusted operating margin CO<sub>2</sub> emission factor in year y (tCO<sub>2</sub>/MWh).
- $\lambda$  = Factor expressing the percentage of time when low-cost/must-run power units are on the margin in year y.
- $EG_{m,y}$  = Net quantity of electricity generated and delivered to the grid by power unit m in year y (MWh).
- $EG_{k,y}$  = Net quantity of electricity generated and delivered to the grid by power unit k in year y (MWh).
- $EF_{EL,m,y}$  = CO<sub>2</sub> emission factor of power unit m in year y (tCO<sub>2</sub>/MWh).
- $EF_{EL,k,y}$  = CO<sub>2</sub> emission factor of power unit k in year y (tCO<sub>2</sub>/MWh).
- $m$  = All grid power units serving the grid in year y except low-cost/must run power units.
- $k$  = All low-cost/must-run grid power units serving the grid in year y.
- $y$  = The relevant year as per the data vintage chosen in Step 3.

According to the baseline methodology, it is possible to calculate the Operating Margin using data vintages for year(s) y:

- *Ex-ante option:* The emission factor is determined once at the validation stage, thus no monitoring and recalculation of the emissions factor during the crediting period is required, or
- *Ex-post option:* The emission factor is determined for the year in which the project activity displaces grid electricity, requiring the emissions factor to be updated annually during monitoring.

The Project Proponent will use the *Ex-post option* to calculate the OM; that is, the OM will be calculated the year in which the project generation occurs.

The Project Proponent will use:

- Option A to calculate the  $EF_{grid,OM-adj,y}$ : Use information based on the net electricity generation and a CO<sub>2</sub> emission factor for each power unit.
- Option A1 for calculating the emission factor of each power unit m: Use information based on fuel consumption and electricity generation of each power unit m.

Step 4: Calculate the operating margin emission factor according to the selected method.

For the calculation of the operating margin, the Project Proponent will use:

- Option A to calculate the  $EF_{grid,OM-adj,y}$ : Use information based on the net electricity generation and a CO<sub>2</sub> emission factor for each power unit.

For the determination of the emission factor of each power unit m,  $EF_{EL,m,y}$  the Project Proponent will choose:

- Option A1: Use information based on fuel consumption and electricity generation for each power unit m.

Note that in this case, the information that is directly available from the Dispatch Centre is the net generation of each power unit m and the corresponding fossil fuel consumption rate.

Step 5: Calculate the build margin (BM) emission factor.

In terms of data vintage, the Project Proponent will choose Option 2:

Option 2: For the first crediting period, the build margin emission factor shall be updated annually, ex-post, including those units build up to the year of registration of the project activity or, if information up to the year of registration is not yet available, including those units build up to the latest year for which information is available. For the second crediting period, the build margin emission factor shall be calculated *ex ante*, as described in Option 1 above. For the third crediting period, the build margin emission factor calculated for the second crediting period should be used.

Step 6: Calculate the combined margin emission factor.

In this case, the proposed project activity is not located in a Least Developed Country (LDC) therefore, according to the corresponding tool for grid emission factor calculation; the combined margin emission factor is calculated according to the following option:

a) Weighted average CM

$$EF_{grid,CM,y} = EF_{grid,OM,y} * w_{OM} + EF_{grid,BM,y} * w_{BM}$$

Where:

$EF_{grid,BM,y}$  = Build margin CO<sub>2</sub> emission factor in year y (tCO<sub>2</sub>/MWh).  
 $EF_{grid,OM,y}$  = Operating margin CO<sub>2</sub> emission factor in year y (tCO<sub>2</sub>/MWh).  
 $w_{OM}$  = Weighting of operating margin emission factor (%).

$w_{BM}$  = Weighting of build margin emission factor (%).

According to the guidance provided by the tool for calculating the grid emission factor, in this case the Project Proponent will use the following default values for  $w_{OM}$  and  $w_{BM}$ :

- Weights:  $w_{OM} = 0.5 = w_{BM} = 0.5$  for the first crediting period and
- Weights:  $w_{OM} = 0.25 = w_{BM} = 0.75$  for the second and third crediting periods.

The values for  $w_{OM}$  and  $w_{BM}$  applied by the Project Proponent will be fixed for a crediting period and may be revised at the renewal of the crediting period.

## **Step 2: Determine the minimum baseline electricity generation in the grid**

The calculation of this parameter is accomplished using equation 13 of the ACM0006 (Version 12.1.1):

$$EL_{BL,GR,y} = \max[0, EL_{BL,y} - CAP_{EG,total,y}]$$

Where:

$EL_{BL,GR,y}$  = Baseline minimum electricity generation in the grid in year y (MWh/yr).  
 $EL_{BL,y}$  = Baseline electricity generation in year y (MWh/yr).  
 $CAP_{EG,total,y}$  = Baseline electricity generation capacity in year y (MWh/yr).  
 $y$  = Year of the crediting period.

## **Step 3: Determination of the baseline biomass-based heat and power generation**

### **Step 3.1: Determination of the baseline biomass-based heat generation**

According to the general principles suggested by the ACM0006 (Version 12.1.1), the Project Proponent will calculate the baseline biomass-based heat generation taking the following project-specific conditions:

The use of biomass residues for which scenario B4 has been identified as the baseline scenario ( $BR_{B4,n,y}$ ) will be prioritized over the use of any fossil fuels in the baseline. From this assumption, the equivalent amount of heat that would be generated with biomass residues ( $HG_{BL,BR,y}$ ) will be determined.

According to the baseline scenario design, there is only one biomass boiler identified in the baseline:

- Saturated steam biomass boiler: This boiler generates saturated steam for heat generation.

This heat generator will run on the biomass residues for which the B4 baseline scenario has been identified: sawdust and bark from industrial operations. Small amounts of fossil fuels can also be used for technical reasons (start-ups or when the biomass is too wet), however in this case such fossil fuel amounts will be disregarded for the baseline scenario (this is conservative).

#### Allocation of biomass residues and fossil fuels:

According to the information provided above, the Project Proponent will allocate 100% of the biomass types for which the B4 baseline scenario applies to the recovery boiler.

Equation 14 is used to calculate the amount of heat generated with biomass residues based on the allocation rules established above:

$$HG_{BL, BR, y} = \sum_h \sum_n (BR_{B4, n, h, y} * NCV_{BR, n, y} * \eta_{BL, HG, BR, h})$$

Subject to the following conditions:

1. The biomass residues used in each heat generator should not exceed the total amount of biomass residues available. This is stated in equation 15 as follows:

$$\sum_h \sum_n BR_{B4, n, h, y} = \sum_n BR_{B4, n, y}$$

2. The heat generation in each heat generator should not exceed the total capacity of the heat generator. This is stated in equation 16 as follows:

$$\sum_n (BR_{B4, n, h, y} * NCV_{BR, n, y} * \eta_{BL, HG, BR, h}) \leq LOC_y * CAP_{HG, h} * LFC_{HFG, h}$$

Where:

- HG<sub>BL, BR, y</sub> = Baseline biomass-based heat generation in year y (GJ/yr).
- BR<sub>B4, n, h, y</sub> = Quantity of biomass residues of category n used in heat generator h in year y with baseline scenario B4 (tonne on dry basis).
- NCV<sub>BR, n, y</sub> = Net calorific value of biomass residue of category n in year y (GJ/tonne on dry basis).
- η<sub>BL, HG, BR, h</sub> = Baseline biomass-based heat generation efficiency of heat generator h (ratio).
- BR<sub>B4, n, y</sub> = Quantity of biomass residues of category n used in the project activity in year y for which the baseline scenario is B4 (tonne on dry basis).
- LOC<sub>y</sub> = Length of the operational campaign in year y (hour).
- CAP<sub>HG, h</sub> = Baseline capacity of heat generator h (GJ/h).
- LFC<sub>HG, h</sub> = Baseline load factor of heat generator h (ratio).
- y = Year of the crediting period.
- h = Heat generator in the baseline scenario.

**Step 3.2: Determination of the baseline biomass-based cogeneration of process heat and electricity and heat extraction**

Not applicable in this case, since there would be no cogeneration in the baseline scenario.

**Step 3.3: Determination of the baseline biomass-based electricity generated in power-only mode**

Not applicable in this case, since there would be no power-only-type heat engines that would be identified in the baseline scenario.

**Step 4: Determination of the baseline demand for fossil fuels to meet the balance of process heat and the corresponding electricity generation**

**Step 4.1: Determination of the baseline fossil fuel based cogeneration of process heat and electricity and the remaining process heat demand**

Not applicable in this case, since there would be no fossil-fuel-based heat generators identified in the baseline scenario. The baseline scenario is designed so that 100% of the heat demand is satisfied by the saturated biomass boiler.

**Step 4.2: Determination of the baseline heat generation to meet the fossil-based cogeneration of heat and power and the heat to meet the balance of process heat**

Not applicable in this case, since there would be no fossil-fuel-based heat generators identified in the baseline scenario. The baseline scenario is designed so that 100% of the heat demand is satisfied by the saturated biomass boiler.

**Step 5: Determination of the baseline emissions due to uncontrolled burning or decay of biomass residues**

In the case of the proposed project activity, the Project Proponent will consider the baseline emissions due to uncontrolled decay of biomass residues. The corresponding emissions are calculated using equation 35 as follows:

$$BE_{BR,y} = BE_{BR,B1/B3,y} + BE_{BR,B2,y}$$

Where:

- BE<sub>BR,y</sub> = Baseline emissions due to disposal of biomass residues in year y (tCO<sub>2e</sub>/yr).
- BE<sub>BR,B1/B3,y</sub> = Baseline emissions due to aerobic decay or uncontrolled burning of biomass residues in year y (tCO<sub>2e</sub>/yr).
- BE<sub>BR,B2,y</sub> = Baseline emissions due to anaerobic decay of biomass residues in year y (tCO<sub>2</sub>/yr).

Since in this case, the biomass residues that would be used for heat and power generation due to the implementation of the project activity would be dumped or left to decay under mainly aerobic conditions (B1), or burnt in an uncontrolled manner without utilizing them for energy purposes (B3), the equation above simplifies to the following:

$$BE_{BR,y} = BE_{BR,B1/B3,y}$$

According to the above, we proceed to step 5.1.

**Step 5.1: Determine BE<sub>BR,B1/B3,y</sub>**

For the biomass residues categories for which the most likely baseline scenario is either that the biomass residues would be dumped or left to decay under mainly aerobic conditions (B1), or burnt in an uncontrolled manner without utilizing them for energy purposes (B3), baseline emission are calculated assuming, for both scenarios (aerobic decay and uncontrolled burning), that the biomass residues would be burnt in an uncontrolled manner.

Baseline emissions are calculated by multiplying the quantity of biomass residues with the net calorific value and appropriate emission factor, as follows:

$$BE_{BR,B1/B3,y} = GWP_{CH4} * \sum_n BR_{B1/B3,n,y} * NCV_{BR,n,y} * EF_{BR,n,y}$$

Where:

- BE<sub>BR,B1/B3,y</sub> = Baseline emissions due to aerobic decay or uncontrolled burning of biomass residues in year y (tCO<sub>2</sub>).

|                    |  |
|--------------------|--|
| $GWP_{CH_4}$ =     | Global Warming Potential of methane valid for the commitment period (tCO <sub>2</sub> e/tCH <sub>4</sub> ).  |
| $BR_{B1/B3,n,y}$ = | Quantity of biomass residues of category n used in the project activity in year y for which the baseline scenario is B1: or B3: (tonnes on dry-basis). |
| $NCV_{BR,n,y}$ =   | Net calorific value of biomass residue of category n in year y (GJ/tonne on dry basis).  |
| $EF_{BR,n,y}$ =    | CH <sub>4</sub> emission factor for uncontrolled burning of the biomass residues category n during the year y (tCH <sub>4</sub> /GJ).                  |
| n =                | Biomass residue category.  |

According to the baseline methodology ACM0006 (Version 12.1.1), page 45, the Project Proponent may undertake measurements or use referenced default values to calculate the CH<sub>4</sub> baseline emissions from uncontrolled burning of biomass. In order to accomplish a higher accuracy in the baseline emission calculations, the Project Proponent conducted a local measurement of this factor at the start of the project activity instead of using the default value provided by the methodology.

During March 2009, the Project Proponent hired the U.S. Forest Service of Missoula, Montana, USA to conduct a measurement of the CH<sub>4</sub> emission factor for uncontrolled burning of the same biomass types that will be burned as a result of the Viñales CDM project activity. The results are the following:

- Biomass from third parties (mix of sawdust and bark): 930 (Kg CH<sub>4</sub>/TJ) and a standard deviation of 168 (Kg CH<sub>4</sub>/TJ).
- Biomass from forestry operations (from harvesting, thinning and pruning operations): 114 (Kg CH<sub>4</sub>/TJ) and a standard deviation of 114 (Kg CH<sub>4</sub>/TJ).

These results were obtained during the dry season in Chile (end of summer), when the biomass is dryer and the weather conditions favor a more efficient combustion of the biomass residues. As a result, these results reflect the lower boundary of methane emission factor that would be obtained if measurements were carried throughout the entire year. This approach was deemed appropriate by the Project Proponent, since it leads to a more conservative emission reduction calculation for the project activity. For more details, please see Annex 3 of this document.

Considering the results above and Table 3 of the ACM0006 (Version 12.1.1) baseline methodology, the corresponding conservativeness factors for these measurements are:

- Biomass from third parties (mix of sawdust and bark): 0.94.
- Biomass from forestry operations (from harvesting, thinning and pruning): 0.89.

These factors led to the following adjusted methane emission factors for the two types of biomass burned:

- Biomass from third parties (mix of sawdust and bark): 874.2 (Kg CH<sub>4</sub>/TJ).
- Biomass from forestry operations (from harvesting, thinning and pruning): 101.46 (Kg CH<sub>4</sub>/TJ).

## 3.2 Project Emissions

Project emissions for the proposed project activity are calculated using equation 37 of the ACM0006 (Version 12.1.1):

$$PE_y = PE_{FF,y} + PE_{GR1,y} + PE_{GR2,y} + PE_{TR,y} + PE_{BR,y} + PE_{WW,y} + PE_{BG2,y} + PE_{BC,y}$$

Where:

|                |   |
|----------------|---|
| $PE_y =$       | Project emissions in year y (tCO <sub>2</sub> /yr).   |
| $PE_{FF,y} =$  | Emissions during the year y due to fossil fuel consumption at the project site (tCO <sub>2</sub> /yr).  |
| $PE_{GR1,y} =$ | Emissions during the year y due to grid electricity imports to the project site (tCO <sub>2</sub> /yr).   |
| $PE_{GR2,y} =$ | Emissions due to a reduction in electricity generation at the project site as compared to the baseline scenario in year y (tCO <sub>2</sub> /yr). |
| $PE_{TR,y} =$  | Emissions during the year y due to transport of the biomass residues to the project plant (tCO <sub>2</sub> /yr).                                 |
| $PE_{BR,y} =$  | Emissions from the combustion of biomass residues during the year y (tCO <sub>2e</sub> /yr).  |
| $PE_{WW,y} =$  | Emissions from waste water generated from the treatment of biomass residues in year y (tCO <sub>2e</sub> /yr).                                    |
| $PE_{BG2,y} =$ | Emissions from the production of biogas in year y (tCO <sub>2e</sub> /yr).  |
| $PE_{BC,y} =$  | Project emissions associated with the cultivation of land to produce biomass in year y (tCO <sub>2e</sub> /yr).                                   |

Considering the particular circumstances of the proposed project activity, the following simplifications apply in this case:

|                  |  |
|------------------|--|
| $PE_{GR2,y} = 0$ | In this case, there would be no electricity generation in the baseline scenario.                               |
| $PE_{WW,y} = 0$  | There will be no anaerobic treatment of waste water generated from the treatment of biomass residues (if any). |
| $PE_{BG2,y} = 0$ | The proposed project activity does not imply the production of biogas.   |
| $PE_{BC,y} = 0$  | The proposed project activity does not contemplate the cultivation of land to produce biomass.                 |

As a result, equation 37 simplifies and reduces to the following:

$$PE_y = PE_{FF,y} + PE_{GR1,y} + PE_{TR,y} + PE_{BR,y}$$

**a) Carbon dioxide emissions from on-site consumption of fossil fuels (PE<sub>FF,y</sub>)**

According to the ACM0006 (Version 12.1.1), the Project Proponent must use the last version of the “Tool to calculate project or leakage CO<sub>2</sub> emissions from fossil fuel combustion”. According to this tool and considering the availability of information in the country in which the proposed project activity is implemented, the Project Proponent will use the following approach for determining CO<sub>2</sub> emissions:

$$PE_{FC,j,y} = \sum_i (FC_{i,j,y} * COEF_{i,y})$$

Where:

|                 |  |
|-----------------|--|
| $PE_{FC,j,y} =$ | CO <sub>2</sub> emissions from fossil fuel combustion in process j during the year y (tCO <sub>2</sub> /yr). |
| $FC_{i,j,y} =$  | Quantity of fuel type i combusted in process j during the year y (mass or volume unit/yr);                   |
| $COEF_{i,y} =$  | CO <sub>2</sub> emission coefficient of fuel type i in year y (tCO <sub>2</sub> /mass or volume unit);       |
| $i =$           | are the fuel types combusted in process j during the year y.   |

The CO<sub>2</sub> emission coefficient COEF<sub>i,y</sub> will be calculated using approach B of the “Tool to calculate project or leakage CO<sub>2</sub> emissions from fossil fuel combustion”, which consists in calculating the coefficient based on the net calorific value and CO<sub>2</sub> emission factor of the fuel type i, as follows:

$$COEF_{i,y} = NCV_{i,y} * EF_{CO2,i,y}$$

Where:

COEF<sub>i,y</sub> = CO<sub>2</sub> emission coefficient of fuel type i in year y (tCO<sub>2</sub>/mass or volume unit);  
 NCV<sub>i,y</sub> = Weighted average net calorific value of the fuel type i in year y (GJ/mass or volume unit);  
 EF<sub>CO2,i,y</sub> = Weighted average CO<sub>2</sub> emission factor of fuel type i in year y (tCO<sub>2</sub>/GJ);  
 i = Fuel types combusted in process j during the year y.

For NCV<sub>i,y</sub> and EF<sub>CO2,i</sub> monitoring, the Project Proponent will use IPCC default values for the emission reduction calculation in this PDD. For subsequent monitoring, the Project Proponent may use other sources, in accordance to the guidance of the ACM0006 (Version 12.1.1) monitoring methodology and the corresponding tool.

Project emissions from on-site fossil fuel consumption must be accounted for the following situations:

- Emissions from on-site fossil fuel consumption for the generation of electric power and heat: In the case of the proposed project activity, these emissions correspond to those related to fossil fuel consumption in the heat generator (e.g. boiler) at the project site.
- Emissions from on-site fossil fuel consumption of auxiliary equipment and systems related to the generation of electric power and heat: In the case of the proposed project activity, these emissions correspond to those related with the transportation of biomass residues to the power boiler. The project activity might also contemplate the mechanical preparation of the biomass residues as well. If so, this emission source will also be considered.

**b) Emissions due to grid electricity imports to the project site (PE<sub>GR1,y</sub>)**

On a general basis, the proposed project activity is designed so that the power plant generates surplus power to the grid. However, under some particular conditions, the proposed project might require to import some electricity from the grid (maintenance periods, start-up operations and other exceptional circumstances). In such cases, this parameter will be monitored and accounted for in the emission reduction calculation, as specified in equation 38 of the ACM0006 (Version 12.1.1).

$$PE_{GR1,y} = EF_{EG,GR,y} * EL_{PJ,imp,y}$$

Where:

PE<sub>GR1,y</sub> = Emissions during the year y due to grid electricity imports to the project site (tCO<sub>2</sub>/yr).  
 EL<sub>PJ,imp,y</sub> = Project electricity imports from the grid in year y (MWh/yr).  
 EF<sub>EG,GR,y</sub> = Grid emission factor in year y (tCO<sub>2</sub>/MWh).

**d) Emissions due to transport of the biomass residues to the project plant (PE<sub>TR,y</sub>)**

According to the ACM0006 (Version 12.1.1), the Project Proponent must determine the CO<sub>2</sub> emissions resulting from transportation of the biomass residues to the project plant using the latest version of the tool “Tool for project and leakage emissions from road transportation of freight”. Note that PE<sub>TR,m</sub> in the tool corresponds to the parameter PE<sub>TR,y</sub> in this methodology and the monitoring period m is one year.

According to the tool, the Project Proponent must specify the following information:

- The origin and destination of the freight (to the extent that this is known at validation);

The Viñales biomass power plant will obtain part of its biomass fuels from third party sawmills in the nearby area. Though the region from which the sawmills will provide the biomass fuels can be known ex-ante, the specific sawmills that will supply the biomass fuels may well vary over time (i.e. some sawmills may close, others may appear, etc.). As a result, the Project Proponent will only specify in this document (Annex 4) the region (communes) from which sawmills that will supply biomass to the Viñales power plant are likely to be located.

- The type(s) of freight that are planned to be transported;

In this case, the freight type will be associated to the transportation of biomass residues to the Viñales biomass power plant.

- The planned number of trips made and/or the planned quantity of freight that should be transported;

In this case, the ex-ante estimated freight will be approximately 330,000 tons (wet) per year of biomass residues.

- The option (A) or (B) to determine the emissions.

In this case, the Project Proponent will use Option B to determine the project emissions from road transportation of freight: Use of conservative default values.

For the purpose of the monitoring of this variable, the Project Proponent will duly document and report the freight transportation activities associated to the proposed project activity in a table like the one below:

| Activity # | Freight type                                 | Weight (t) | Origin            | Destination   | Road distance (km) | Vehicle class |
|------------|--|------------|-------------------|---------------|--------------------|---------------|
| 1          | Sawdust and bark from industrial operations. | 24         | Collection site A | Project plant | 85                 | Heavy         |
| 2          | Sawdust and bark from industrial operations. | 20         | Collection site B | Project plant | 100                | Heavy         |
| Etc.       | Etc.   | Etc.       | Etc.              | Etc.          | Etc.               | Etc.          |

According to the tool, the corresponding project emissions are calculated using the following equation:

$$PE_{TR,y} = \sum_f D_{f,m} * FR_{f,m} * EF_{CO_2,f} * 10^{-6}$$

Where:

- PE<sub>TR,y</sub> = Project emissions from road transportation of freight monitoring period y (tCO<sub>2</sub>).
- D<sub>f,y</sub> = Return trip road distance between the origin and destination of freight transportation activity f in monitoring period y (km).
- FR<sub>f,y</sub> = Total mass of freight transported in freight transportation activity f in monitoring period y (t).
- EF<sub>CO<sub>2</sub>,f</sub> = Default CO<sub>2</sub> emission factor for freight transportation activity f (g CO<sub>2</sub>/t km).
- f = Freight transportation activities conducted in the project activity in monitoring period y.

**d) Emissions from the combustion of biomass residues (PE<sub>BR,y</sub>)**

Since this source is included in the project boundary, emissions are calculated using equation 40 of the ACM0006 (Version 12.1.1):

$$PE_{BR,y} = GWP_{CH_4} * EF_{CH_4,BR} * \sum_k BR_{PJ,n,y} * NCV_{BR,n,y}$$

Where:

- PE<sub>BR,y</sub> = Emissions from the combustion of biomass residues during the year y (tCO<sub>2</sub>e/yr).
- GWP<sub>CH<sub>4</sub></sub> = Global Warming Potential of methane valid for the commitment period (tCO<sub>2</sub>/tCH<sub>4</sub>).
- EF<sub>CH<sub>4</sub>,BR</sub> = CH<sub>4</sub> emission factor for the combustion of biomass residues in the project plant (tCH<sub>4</sub>/GJ).
- BR<sub>PJ,n,y</sub> = Quantity of biomass residues of category n used in the project activity in year y (tonnes on dry-basis).
- NCV<sub>BR,n,y</sub> = Net calorific value of biomass residue of category n in year y (GJ/tonne on dry-basis).

The methodology provides in Tables 4 and 5 of the ACM0006 (Version 12.1.1) default values and conservativeness factors for the methane emission factor. The values and the corresponding justification are presented in the section of the data and parameters available at the validation.

**3.3 Leakage**

According to the ACM0006 (Version 12.1.1), the baseline scenarios for biomass residues for which potential leakage is relevant are: B5:, B6:, B7: and B8:. As can be seen in section 2.4 of this document, the biomass baseline scenarios that are relevant for the Viñales project activity are B1: and B3:. As a result, no leakage must be considered for these biomass types.

However, since the ACM0006 (Version 12.1.1) contemplates the possibility of incorporating new types of biomass during the crediting period, leakage might be relevant for the new biomass types that are incorporated to the project.

For the biomass categories whose baseline scenarios has been identified as B5:, B6:, B7: or B8:, project participants shall calculate leakage emissions using equation 42 of the ACM0006 (Version 12.1.1) as follows:

$$LE_y = EF_{CO_2,LE} * \sum_n BR_{B5/B8,n,y} * NCV_{BR,n,y}$$

Where:

- LE<sub>y</sub> = Leakage emissions in year y (tCO<sub>2</sub>).
- EF<sub>CO<sub>2</sub>,LE</sub> = CO<sub>2</sub> emission factor of the most carbon intensive fossil fuel used in the country (tCO<sub>2</sub>/GJ).
- BR<sub>B5/B8,n,y</sub> = Quantity of biomass residues of category n used in the project activity in year y for which the baseline scenario is B5:, B6:, B7: or B8: (tonnes on dry-basis).
- GWP<sub>CH<sub>4</sub></sub> = Global Warming Potential of methane valid for the commitment period (tCO<sub>2</sub>e/tCH<sub>4</sub>).
- NCV<sub>BR,n,y</sub> = Net calorific value of biomass residue of category n in year y (GJ/tonne on dry basis).
- n = Biomass residue category.
- y = Year of the crediting period.

The determination of  $BR_{B5/B8,n,y}$  shall be based on the monitored amounts of biomass residues used in power plants included in the project boundary.

In the case that negative overall emission reductions arise in a year through application of the leakage emissions, emission reductions are not issued to project participants for the year concerned and in subsequent years, until emission reductions from subsequent years have compensated the quantity of negative emission reductions from the year concerned.

### 3.4 Summary of GHG Emission Reductions and Removals

| Years        | Estimated baseline emissions or removals (tCO <sub>2</sub> e) | Estimated project emissions or removals (tCO <sub>2</sub> e) | Estimated leakage emissions (tCO <sub>2</sub> e) | Estimated net GHG emission reductions or removals (tCO <sub>2</sub> e) |
|--------------|---|--|--|--|
| 2014         | 273,631   | 15,538   | 0  | 258,093  |
| 2015         | 273,631   | 15,538   | 0  | 258,093  |
| 2016         | 273,631   | 15,538   | 0  | 258,093  |
| 2017         | 273,631   | 15,538   | 0  | 258,093  |
| 2018         | 273,631   | 15,538   | 0  | 258,093  |
| 2019         | 273,631   | 15,538   | 0  | 258,093  |
| 2020         | 273,631   | 15,538   | 0  | 258,093  |
| 2021         | 273,631   | 15,538   | 0  | 258,093  |
| 2022         | 273,631   | 15,538   | 0  | 258,093  |
| 2023         | 273,631   | 15,538   | 0  | 258,093  |
| <b>Total</b> | <b>2,736,308</b>  | <b>155,379</b>   | <b>0</b>   | <b>2,580,929</b>   |

## 4 MONITORING

### 4.1 Data and Parameters Available at Validation

|                        |  |
|------------------------|--|
| Data Unit / Parameter: | <b>Biomass residues categories and quantities used for the selection of the baseline scenario selection and assessment of additionality.</b>   |
| Data unit:             | <ul style="list-style-type: none"> <li>- Type (i.e. bagasse, rice husks, empty fruit bunches, etc.);</li> <li>- Source (e.g. produced on-site, obtained from an identified biomass residues producer, obtained from a biomass residues market, etc.);</li> <li>- Fate in the absence of the project activity (scenarios B);</li> <li>- Use in the project scenario (scenarios P);</li> </ul> |

|   | - Quantity (tonnes on dry-basis).   |                            |  |   |  |  |   |   |  |                    |  |   |        |   |  |                    |  |   |        |   |  |                     |  |   |         |   |                                   |                     |  |   |        |
|---|---|----------------------------|--|---|--|--|---|---|--|--------------------|--|---|--------|---|--|--------------------|--|---|--------|---|--|---------------------|--|---|---------|---|-----------------------------------|---------------------|--|---|--------|
| Description:  | The biomass quantities provided in the table below were determined ex-ante in accordance with the pulp mill project studies.  |                            |  |   |  |  |   |   |  |                    |  |   |        |   |  |                    |  |   |        |   |  |                     |  |   |         |   |                                   |                     |  |   |        |
| Source of data:   | On-site assessment of biomass residues categories and quantities.   |                            |  |   |  |  |   |   |  |                    |  |   |        |   |  |                    |  |   |        |   |  |                     |  |   |         |   |                                   |                     |  |   |        |
| Value applied:  | See table below: <table border="1" style="width: 100%; border-collapse: collapse;"> <thead> <tr> <th style="width: 10%;">Biomass residue category k</th> <th style="width: 20%;">Biomass residues type</th> <th style="width: 15%;">Biomass residue source</th> <th style="width: 20%;">Biomass residues fate in the absence of the project activity</th> <th style="width: 15%;">Biomass residues use in project scenario</th> <th style="width: 20%;">Biomass residues quantity (dry tonnes/yr)</th> </tr> </thead> <tbody> <tr> <td>1</td> <td>Sawdust and bark from industrial operations.</td> <td>On-site production</td> <td>Heat and power generation on-site (B4)</td> <td>Heat and power generation on-site (biomass-only boiler)</td> <td>65,417</td> </tr> <tr> <td>2</td> <td>Sawdust and bark from industrial operations.</td> <td>On-site production</td> <td>Dumped and/or burned in the open air (B1: and/or B3:).</td> <td>Heat and power generation on-site (biomass-only boiler)</td> <td>83,786</td> </tr> <tr> <td>3</td> <td>Sawdust and bark from industrial operations.</td> <td>Off-site production</td> <td>Dumped and/or burned in the open air (B1: and/or B3:).</td> <td>Heat and power generation on-site (biomass-only boiler)</td> <td>128,052</td> </tr> <tr> <td>4</td> <td>Biomass from forestry operations.</td> <td>Off-site production</td> <td>Dumped and/or burned in the open air (B1: and/or B3:).</td> <td>Heat and power generation on-site (biomass-only boiler)</td> <td>35,500</td> </tr> </tbody> </table> | Biomass residue category k | Biomass residues type  | Biomass residue source                                  | Biomass residues fate in the absence of the project activity | Biomass residues use in project scenario | Biomass residues quantity (dry tonnes/yr) | 1 | Sawdust and bark from industrial operations. | On-site production | Heat and power generation on-site (B4) | Heat and power generation on-site (biomass-only boiler) | 65,417 | 2 | Sawdust and bark from industrial operations. | On-site production | Dumped and/or burned in the open air (B1: and/or B3:). | Heat and power generation on-site (biomass-only boiler) | 83,786 | 3 | Sawdust and bark from industrial operations. | Off-site production | Dumped and/or burned in the open air (B1: and/or B3:). | Heat and power generation on-site (biomass-only boiler) | 128,052 | 4 | Biomass from forestry operations. | Off-site production | Dumped and/or burned in the open air (B1: and/or B3:). | Heat and power generation on-site (biomass-only boiler) | 35,500 |
| Biomass residue category k  | Biomass residues type   | Biomass residue source     | Biomass residues fate in the absence of the project activity | Biomass residues use in project scenario                | Biomass residues quantity (dry tonnes/yr)                    |  |   |   |  |                    |  |   |        |   |  |                    |  |   |        |   |  |                     |  |   |         |   |                                   |                     |  |   |        |
| 1   | Sawdust and bark from industrial operations.  | On-site production         | Heat and power generation on-site (B4)                       | Heat and power generation on-site (biomass-only boiler) | 65,417   |  |   |   |  |                    |  |   |        |   |  |                    |  |   |        |   |  |                     |  |   |         |   |                                   |                     |  |   |        |
| 2   | Sawdust and bark from industrial operations.  | On-site production         | Dumped and/or burned in the open air (B1: and/or B3:).       | Heat and power generation on-site (biomass-only boiler) | 83,786   |  |   |   |  |                    |  |   |        |   |  |                    |  |   |        |   |  |                     |  |   |         |   |                                   |                     |  |   |        |
| 3   | Sawdust and bark from industrial operations.  | Off-site production        | Dumped and/or burned in the open air (B1: and/or B3:).       | Heat and power generation on-site (biomass-only boiler) | 128,052  |  |   |   |  |                    |  |   |        |   |  |                    |  |   |        |   |  |                     |  |   |         |   |                                   |                     |  |   |        |
| 4   | Biomass from forestry operations.   | Off-site production        | Dumped and/or burned in the open air (B1: and/or B3:).       | Heat and power generation on-site (biomass-only boiler) | 35,500   |  |   |   |  |                    |  |   |        |   |  |                    |  |   |        |   |  |                     |  |   |         |   |                                   |                     |  |   |        |
| Justification of choice of data or description of measurement methods and procedures applied: | The Project Proponent hired reputed consultants for the development of the new power plant and the estimation ex-ante of the biomass types and quantities.  |                            |  |   |  |  |   |   |  |                    |  |   |        |   |  |                    |  |   |        |   |  |                     |  |   |         |   |                                   |                     |  |   |        |
| Any comment:  | This parameter is related to the procedure for the selection of the baseline scenario selection and assessment of additionality.  |                            |  |   |  |  |   |   |  |                    |  |   |        |   |  |                    |  |   |        |   |  |                     |  |   |         |   |                                   |                     |  |   |        |

|                        |  |
|------------------------|--|
| Data Unit / Parameter: | <b>P<sub>x</sub></b>   |
| Data unit:             | Cubic meters   |
| Description:           | P <sub>x</sub> = Quantity of the main product of the production process (e.g. sugar cane, rice) produced in year x from plants operated at the |

|   |   |
|---|---|
|   | project site.   |
| Source of data:   | On-site measurements.   |
| Value applied:  | <ul style="list-style-type: none"> <li>• 352,686 m<sup>3</sup>/yr of sawn timber from the sawmill.</li> <li>• 88,203 m<sup>3</sup> of processed wood products from the remanufacture plant.</li> </ul> <p>These production levels correspond to the averages between the productions of 2012 and 2013 respectively. Production levels might vary from year to year, depending on market conditions.</p> |
| Justification of choice of data or description of measurement methods and procedures applied: | ---   |
| Any comment:  | ---   |

|   |  |
|---|--|
| Data Unit / Parameter:  | <b>CAP<sub>HG,h</sub></b>  |
| Data unit:  | (GJ/h)   |
| Description:  | CAP <sub>HG,h</sub> = Baseline capacity of heat generator h (GJ/h).  |
| Source of data:   | Reference plant design parameters.   |
| Value applied:  | 210 (GJ/h)   |
| Justification of choice of data or description of measurement methods and procedures applied: | This parameter reflects the design maximum heat generation capacity (in GJ/h) of the baseline heat generation h. This parameter was determined by Arauco based on its previous experience with saturated heat generators in other sawmills and on the Viñales sawmill heat requirements. |
| Any comment:  | ---  |

|  |   |
|--|---|
| Data Unit / Parameter:                         | <b>LFC<sub>HG,h</sub></b>   |
| Data unit:                                     | Ratio.  |
| Description:                                   | LFC <sub>HG,h</sub> = Baseline load factor of heat generator h (ratio). |
| Source of data:                                | Reference plant design parameters.                                      |
| Value applied:                                 | 90%   |
| Justification of choice of data or description | This parameter reflects the maximum load factor                         |

|  |  |
|--|--|
| of measurement methods and procedures applied: | (i.e. the ratio between the “actual heat generation” of the heat generator and its “design maximum heat generation” along one year of operation) of the baseline heat generator $h$ , taking into account downtime due to maintenance, seasonal operational patterns and any other technical constraints.<br><br>In this case, this parameter was determined from the baseline study carried out for the Viñales project and other similar/comparable projects in other Arauco sawmill facilities. |
| Any comment:                                   | ---  |

|   |  |
|---|--|
| Data Unit / Parameter:  | <b>GWP<sub>CH4</sub></b>   |
| Data unit:  | (tCO <sub>2e</sub> /tCH <sub>4</sub> ).  |
| Description:  | GWP <sub>CH4</sub> = Global Warming Potential of methane valid for the commitment period (tCO <sub>2</sub> /tCH <sub>4</sub> ).      |
| Source of data:   | IPCC   |
| Value applied:  | 21 for the first commitment period. 25 for the second commitment period. Shall be updated according to any future COP/MOP decisions. |
| Justification of choice of data or description of measurement methods and procedures applied: | ---  |
| Any comment:  | ---  |

|                        |   |
|------------------------|---|
| Data Unit / Parameter: | <b>EF<sub>burning,CH4,k,y</sub></b>   |
| Data unit:             | (tCH <sub>4</sub> /GJ)  |
| Description:           | CH <sub>4</sub> emission factor for uncontrolled burning of the biomass residue type $k$ during year $y$ .  |
| Source of data:        | Direct measurements before the start of the project activity.   |
| Value applied:         | <ul style="list-style-type: none"> <li>Biomass residues from industrial operations (mainly sawdust and bark from sawmills): 0.0008742 (tCH<sub>4</sub>/GJ) or 874.2 (Kg CH<sub>4</sub>/TJ). This value includes the adjustment of a conservativeness factor of 0.94.</li> <li>Biomass residues from forestry operations (mainly branches from harvesting, pruning and thinning operations): 0.00010146 (tCH<sub>4</sub>/GJ) or 101.46 (Kg CH<sub>4</sub>/TJ). This value</li> </ul> |

|   |  |
|---|--|
|   | includes the adjustment of a conservativeness factor of 0.89.  |
| Justification of choice of data or description of measurement methods and procedures applied: | The CH <sub>4</sub> measurement was performed for the biomass types that will be used as a result of the implementation of the Viñales project activity. For a detailed description on the methods used, please see Annex 3 of this document.  |
| Any comment:  | Differences between IPCC default values and the measured values are due to the compactness level of the biomass residues burned. In case of the biomass from industrial operations, the biomass is densely packed allowing for very little oxygen in the combustion process. This leads to high methane emission factors. In the case of the biomass from forestry operations, the biomass (mainly branches) allow for plenty of oxygen during the combustion, which leads to much lower methane emission factors. The measured values are consistent with values obtained in other parts of the world under similar conditions. |

|   |  |
|---|--|
| Data Unit / Parameter:  | <b>EF<sub>CH<sub>4</sub>,BR</sub></b>  |
| Data unit:  | (tCH <sub>4</sub> /GJ)   |
| Description:  | EF <sub>CH<sub>4</sub>,BR</sub> = CH <sub>4</sub> emission factor for the combustion of biomass residues in the project plant (tCH <sub>4</sub> /GJ).  |
| Source of data:   | On-site measurements or default values, as provided in Table 4 and 5 of the ACM0006 (Version 12.1.1).  |
| Value applied:  | 30 kg CH <sub>4</sub> /TJ (unadjusted factor).<br><br>41.1 kg CH <sub>4</sub> /TJ using conservativeness factor of 1.37 from Table 5 (maximum uncertainty).  |
| Justification of choice of data or description of measurement methods and procedures applied: | The measured CH <sub>4</sub> emission factors are adjusted by a conservatism value, thus ensuring the appropriateness and conservativeness of the associated emission reduction calculation.<br><br>Likewise, the default emission factors provided by the methodology are conservative per se and are further adjusted using conservativeness factors provided by the methodology. This |

|              |   |
|--------------|---|
|              | ensures the conservativeness of the emission reduction calculation.   |
| Any comment: | The Project Proponent will use the default values in this case. However, the Project Proponent might consider measuring this emission factor in the future. In such case, the Project Proponent will present the corresponding request for deviation, in accordance with the VCS rules. |

|   |  |
|---|--|
| Data Unit / Parameter:  | $\eta_{BL,HG,BR,boiler}$   |
| Data unit:  | (%)  |
| Description:  | Heat efficiency of the boiler (heat generator) that would have been installed in the baseline scenario.  |
| Source of data:   | Baseline plant design parameter defined by Energy Industry consultant. The same value has been recently used by the Project Proponent in other similar emission reduction project activities under the CDM.  |
| Value applied:  | 85%  |
| Justification of choice of data or description of measurement methods and procedures applied: | As stated above, the proposed value has been used in other similar emission reduction project activities implemented in Chile and has been suggested by reputable engineering and technology companies such as Metso and Andritz. The value is realistic and furthermore, leads to a more conservative emission reduction calculation than the default value that is proposed in the "Tool to determine the baseline efficiency of thermal or electric energy generation systems". |
| Any comment:  | --   |

**Data and parameters not monitored from the tool: "Project and leakage emissions from road transportation of freight" (Version 01.0.0)**

|                        |               |
|------------------------|---------------|
| Data Unit / Parameter: | $EF_{CO_2,f}$ |
|------------------------|---------------|

| Data unit:  | (g CO <sub>2</sub> /t km)   |               |   |                |     |                |     |
|---|---|---------------|---|----------------|-----|----------------|-----|
| Description:  | Default CO <sub>2</sub> emission factor for freight transportation activity <i>f</i> .  |               |   |                |     |                |     |
| Source of data:   |   |               |   |                |     |                |     |
| Value applied:  | <table border="1"> <thead> <tr> <th>Vehicle class</th> <th>Emission factor (g CO<sub>2</sub>/t km)</th> </tr> </thead> <tbody> <tr> <td>Light vehicles</td> <td>245</td> </tr> <tr> <td>Heavy vehicles</td> <td>129</td> </tr> </tbody> </table> <p>In this case, the Project Proponent will use the emission factor according to the type of vehicle (i.e. light/heavy) used in the transportation of the biomass residues to the Viñales power plant.</p>   | Vehicle class | Emission factor (g CO <sub>2</sub> /t km) | Light vehicles | 245 | Heavy vehicles | 129 |
| Vehicle class   | Emission factor (g CO <sub>2</sub> /t km)   |               |   |                |     |                |     |
| Light vehicles  | 245   |               |   |                |     |                |     |
| Heavy vehicles  | 129   |               |   |                |     |                |     |
| Justification of choice of data or description of measurement methods and procedures applied: | The default values are proposed in the corresponding CDM tool and therefore are deemed conservative and appropriate in this case.   |               |   |                |     |                |     |
| Any comment:  | Applicable to Option B. The default CO <sub>2</sub> emission factors take into account emissions generated by loaded outbound trips and empty return trips. The default emission factors have been obtained from two sources. For light vehicles, the emission factor was obtained from empirical data from European vehicles. For heavy vehicles, the emission factor has been derived based on custom design transient speed-time-gradient drive cycle (adapted from the international FIGE cycle), vehicle dimensional data, mathematical analysis of loading scenarios, and dynamic modelling based on engine power profiles, which, in turn, are a function of gross vehicle mass (GVM), load factor, speed/acceleration profiles and road gradient. The following assumptions on key parameters have been made: an average driving speed of 30 km/h, and average gradient of 1%, and a load factor attained when biomass is transported is assumed. |               |   |                |     |                |     |

#### 4.2 Data and Parameters Monitored

|                        |   |
|------------------------|---|
| Data Unit / Parameter: | <b>Biomass residues categories and quantities used in the project activity.</b> |
|------------------------|---|

| Data unit:   | <ul style="list-style-type: none"> <li>- Type (i.e. bagasse, rice husks, empty fruit bunches, etc.);</li> <li>- Source (e.g. produced on-site, obtained from an identified biomass residues producer, obtained from a biomass residues market, etc.);</li> <li>- Fate in the absence of the project activity (scenarios B);</li> <li>- Use in the project scenario (scenarios P and H);</li> <li>- Quantity (tonnes on dry-basis).</li> </ul>  |                          |                              |                         |                              |                         |                           |
|--|--|--------------------------|------------------------------|-------------------------|------------------------------|-------------------------|---------------------------|
| Description:   | The biomass quantities provided in the table below were determined ex-ante by feasibility studies by Arauco. All these amounts (as well as the ones that eventually might be incorporated later on) will be continuously monitored in the project plant, according to proper industry standards.   |                          |                              |                         |                              |                         |                           |
| Source of data:  | On-site measurements and calculations.   |                          |                              |                         |                              |                         |                           |
| Description of measurement methods and procedures to be applied: | <p>Most of the internal biomass residues will be measured at the entrance of the biomass power plant, using dedicated weight bridges. The rest of the internal biomass residues that are transported via the pneumatic transportation system will be estimated using calculations (see the Annex at the end of this document). The external biomass residues will be all measured using dedicated weight-bridges.</p> <p>The origin of the biomass (internal: the Viñales sawmill or external: from third parties) will be duly recorded as well as the biomass type (biomass residues from industrial operations or biomass residues from forestry operations) in each case.</p> <p>Since there is no (significant) buffer for biomass storage (just 3 to 4 days of operation), the Project Proponent will consider that all the biomass that enters the power plant is consumed.</p> <p>Dry weight of all biomass residues will be subsequently determined using the biomass moisture content of the corresponding biomass type.</p> |                          |                              |                         |                              |                         |                           |
| Frequency of monitoring/recording:                               | Data monitored continuously and aggregated as appropriate, to calculate emissions reductions.  |                          |                              |                         |                              |                         |                           |
| Value applied:   | See table below.   |                          |                              |                         |                              |                         |                           |
|  | <table border="1"> <thead> <tr> <th>Biomass residue category</th> <th>Biomass residues type</th> <th>Biomass residue source</th> <th>Biomass residues fate in the</th> <th>Biomass residues use in</th> <th>Biomass residues quantity</th> </tr> </thead> </table>   | Biomass residue category | Biomass residues type        | Biomass residue source  | Biomass residues fate in the | Biomass residues use in | Biomass residues quantity |
| Biomass residue category   | Biomass residues type  | Biomass residue source   | Biomass residues fate in the | Biomass residues use in | Biomass residues quantity    |                         |                           |

|  | k |  |                     | absence of the project activity                        | project scenario  | (dry tonnes/yr) |
|--|---|--|---------------------|--|---|-----------------|
|  | 1 | Sawdust and bark from industrial operations. | On-site production  | Heat and power generation on-site (B4)                 | Heat and power generation on-site (biomass-only boiler) | 65,417          |
|  | 2 | Sawdust and bark from industrial operations. | On-site production  | Dumped and/or burned in the open air (B1: and/or B3:). | Heat and power generation on-site (biomass-only boiler) | 83,786          |
|  | 3 | Sawdust and bark from industrial operations. | Off-site production | Dumped and/or burned in the open air (B1: and/or B3:). | Heat and power generation on-site (biomass-only boiler) | 128,052         |
|  | 4 | Biomass from forestry operations.            | Off-site production | Dumped and/or burned in the open air (B1: and/or B3:). | Heat and power generation on-site (biomass-only boiler) | 35,500          |

| Monitoring equipment:           | <p>See table below:</p> <table border="1"> <thead> <tr> <th data-bbox="639 222 769 323">Biomass residue category k</th> <th data-bbox="774 222 953 275">Biomass residues type</th> <th data-bbox="958 222 1382 275">Biomass residue monitoring equipment description</th> </tr> </thead> <tbody> <tr> <td data-bbox="639 329 769 422">1</td> <td data-bbox="774 329 953 422">Sawdust and bark from industrial operations.</td> <td data-bbox="958 329 1382 695" rowspan="4">Equipment type: Weighbridge<br/>Manufacturer: Pesamatic (GSE)<br/>Model: Dynamic system 460<br/>Serial number: Version 4.0.0 (162069)<br/>Calibration date: 26/11/2012<br/>Accuracy class: III (3)</td> </tr> <tr> <td data-bbox="639 428 769 520">2</td> <td data-bbox="774 428 953 520">Sawdust and bark from industrial operations.</td> </tr> <tr> <td data-bbox="639 527 769 619">3</td> <td data-bbox="774 527 953 619">Sawdust and bark from industrial operations.</td> </tr> <tr> <td data-bbox="639 625 769 695">4</td> <td data-bbox="774 625 953 695">Biomass from forestry operations.</td> </tr> </tbody> </table> | Biomass residue category k  | Biomass residues type | Biomass residue monitoring equipment description | 1 | Sawdust and bark from industrial operations. | Equipment type: Weighbridge<br>Manufacturer: Pesamatic (GSE)<br>Model: Dynamic system 460<br>Serial number: Version 4.0.0 (162069)<br>Calibration date: 26/11/2012<br>Accuracy class: III (3) | 2 | Sawdust and bark from industrial operations. | 3 | Sawdust and bark from industrial operations. | 4 | Biomass from forestry operations. |
|---------------------------------|--|---|-----------------------|--|---|--|---|---|--|---|--|---|-----------------------------------|
| Biomass residue category k      | Biomass residues type  | Biomass residue monitoring equipment description  |                       |  |   |  |   |   |  |   |  |   |                                   |
| 1                               | Sawdust and bark from industrial operations.   | Equipment type: Weighbridge<br>Manufacturer: Pesamatic (GSE)<br>Model: Dynamic system 460<br>Serial number: Version 4.0.0 (162069)<br>Calibration date: 26/11/2012<br>Accuracy class: III (3) |                       |  |   |  |   |   |  |   |  |   |                                   |
| 2                               | Sawdust and bark from industrial operations.   |   |                       |  |   |  |   |   |  |   |  |   |                                   |
| 3                               | Sawdust and bark from industrial operations.   |   |                       |  |   |  |   |   |  |   |  |   |                                   |
| 4                               | Biomass from forestry operations.  |   |                       |  |   |  |   |   |  |   |  |   |                                   |
| QA/QC procedures to be applied: | Crosscheck the measurements with an annual energy balance that is based on purchased quantities and stock changes.   |   |                       |  |   |  |   |   |  |   |  |   |                                   |
| Calculation method:             | For the biomass residues generated on-site that are transported by the pneumatic transportation system, please see the description of the calculation method in Annex 1, at the end of this document.  |   |                       |  |   |  |   |   |  |   |  |   |                                   |
| Any comment:                    | ---  |   |                       |  |   |  |   |   |  |   |  |   |                                   |

|  |  |
|--|--|
| Data Unit / Parameter:   | <b>For biomass residues categories for which scenarios B1:, B2: or B3: is deemed a plausible baseline alternative, project participants shall demonstrate that this is a realistic and credible alternative scenario.</b>  |
| Data unit:   | (Tonnes)   |
| Description:   | <ul style="list-style-type: none"> <li>- Quantity of available biomass residues of type n in the region.</li> <li>- Quantity of biomass residues of type n that are utilized (e.g. for energy generation or as feedstock) in the defined geographical region.</li> <li>- Availability of a surplus of biomass residues type n (which cannot be sold or utilized) at the ultimate supplier to the project and a representative sample of other suppliers in the defined geographical region.</li> </ul> |
| Source of data:  | Official national surveys and statistics.  |
| Description of measurement methods and procedures to be applied: | Not applicable in this case.   |
| Frequency of monitoring/recording:                               | At the validation stage for biomass residues categories identified <i>ex-ante</i> , and always that new biomass residues categories are included during the crediting period.  |
| Value applied:   | <p>Not applicable in this case.</p> <p>The Project Proponent will use the first approach to support the selection of the baseline scenario B1/B3 for the additional biomass residues used under the project activity. See page 14 of the ACM0006 (Version 12.1.1).</p>   |
| Monitoring equipment:  | Not applicable in this case.   |
| QA/QC procedures to be applied:                                  | Not applicable in this case.   |
| Calculation method:  | Not applicable in this case.   |
| Any comment:   | ---  |

|  |  |  |                               |   |   |  |
|--|--|--|-------------------------------|---|---|--|
| Data Unit / Parameter:   | <b>BR<sub>P,J,n,y</sub></b>  |  |                               |   |   |  |
| Data unit:   | (Tonnes on dry basis)  |  |                               |   |   |  |
| Description:   | BR <sub>P,J,n,y</sub> = Quantity of biomass residues of category n used in the project activity in year y (tonnes on dry-basis).                   |  |                               |   |   |  |
| Source of data:  | On-site measurements.  |  |                               |   |   |  |
| Description of measurement methods and procedures to be applied: | Please see the corresponding section of the parameter: "Biomass residues categories and quantities used in the project activity".                  |  |                               |   |   |  |
| Frequency of monitoring/recording:                               | Data monitored continuously and aggregated as appropriate, to calculate emission reductions.   |  |                               |   |   |  |
| Value applied:   | See table below.   |  |                               |   |   |  |
|  | <b>Biomass residue category k</b>  | <b>Biomass residues type</b>                 | <b>Biomass residue source</b> | <b>Biomass residues fate in the absence of the project activity</b> | <b>Biomass residues use in project scenario</b>         | <b>Biomass residues quantity (dry tonnes/yr)</b> |
|  | 1  | Sawdust and bark from industrial operations. | On-site production            | Heat and power generation on-site (B4)                              | Heat and power generation on-site (biomass-only boiler) | 65,417   |
|  | 2  | Sawdust and bark from industrial operations. | On-site production            | Dumped and/or burned in the open air (B1: and/or B3:).              | Heat and power generation on-site (biomass-only boiler) | 83,786   |
|  | 3  | Sawdust and bark from industrial operations. | Off-site production           | Dumped and/or burned in the open air (B1: and/or B3:).              | Heat and power generation on-site (biomass-only boiler) | 128,052  |
|  | 4  | Biomass from forestry operations.            | Off-site production           | Dumped and/or burned in the open air (B1: and/or B3:).              | Heat and power generation on-site (biomass-only boiler) | 35,500   |
| Monitoring equipment:  | See table describing the monitoring equipment procedures under variable "Biomass residues categories and quantities used in the project activity". |  |                               |   |   |  |
| QA/QC procedures to be applied:                                  | Crosscheck the measurements with an annual energy balance that is based on purchased quantities and stock changes.                                 |  |                               |   |   |  |

|                     |   |
|---------------------|---|
| Calculation method: | Please see the corresponding section of the parameter: "Biomass residues categories and quantities used in the project activity".   |
| Any comment:        | The biomass residue quantities used should be monitored separately for each type of biomass residue and each source (e.g. produced on-site, obtained from biomass residues suppliers, obtained from a biomass residues market, obtained from an identified biomass residues producer, etc.). Biogas should be included as appropriate if applicable (in which case convenient units such as m <sup>3</sup> should be used). |

| Data Unit / Parameter:   | <b>BR<sub>B4,n,y</sub></b>  |                            |  |   |  |  |   |   |  |                    |  |   |        |
|--|---|----------------------------|--|---|--|--|---|---|--|--------------------|--|---|--------|
| Data unit:   | (Tonnes on dry basis)   |                            |  |   |  |  |   |   |  |                    |  |   |        |
| Description:   | BR <sub>B4,n,y</sub> = Quantity of biomass residues of category n used in the project activity in year y for which the baseline scenario is B4: (tonne on dry-basis).   |                            |  |   |  |  |   |   |  |                    |  |   |        |
| Source of data:  | On-site measurements.   |                            |  |   |  |  |   |   |  |                    |  |   |        |
| Description of measurement methods and procedures to be applied: | Please see the corresponding section of the parameter: "Biomass residues categories and quantities used in the project activity".   |                            |  |   |  |  |   |   |  |                    |  |   |        |
| Frequency of monitoring/recording:                               | Data monitored continuously and aggregated as appropriate, to calculate emission reductions.  |                            |  |   |  |  |   |   |  |                    |  |   |        |
| Value applied:   | See table below. <table border="1" data-bbox="646 1411 1421 1759"> <thead> <tr> <th>Biomass residue category k</th> <th>Biomass residues type</th> <th>Biomass residue source</th> <th>Biomass residues fate in the absence of the project activity</th> <th>Biomass residues use in project scenario</th> <th>Biomass residues quantity (dry tonnes/yr)</th> </tr> </thead> <tbody> <tr> <td>1</td> <td>Sawdust and bark from industrial operations.</td> <td>On-site production</td> <td>Heat and power generation on-site (B4)</td> <td>Heat and power generation on-site (biomass-only boiler)</td> <td>65,417</td> </tr> </tbody> </table> | Biomass residue category k | Biomass residues type  | Biomass residue source                                  | Biomass residues fate in the absence of the project activity | Biomass residues use in project scenario | Biomass residues quantity (dry tonnes/yr) | 1 | Sawdust and bark from industrial operations. | On-site production | Heat and power generation on-site (B4) | Heat and power generation on-site (biomass-only boiler) | 65,417 |
| Biomass residue category k                                       | Biomass residues type   | Biomass residue source     | Biomass residues fate in the absence of the project activity | Biomass residues use in project scenario                | Biomass residues quantity (dry tonnes/yr)                    |  |   |   |  |                    |  |   |        |
| 1  | Sawdust and bark from industrial operations.  | On-site production         | Heat and power generation on-site (B4)                       | Heat and power generation on-site (biomass-only boiler) | 65,417   |  |   |   |  |                    |  |   |        |
| Monitoring equipment:  | See table describing the monitoring equipment procedures under variable "Biomass residues categories and quantities used in the project activity".  |                            |  |   |  |  |   |   |  |                    |  |   |        |

|                                 |  |
|---------------------------------|--|
| QA/QC procedures to be applied: | Crosscheck the measurements with an annual energy balance that is based on purchased quantities and stock changes.   |
| Calculation method:             | Please see the corresponding section of the parameter: "Biomass residues categories and quantities used in the project activity".  |
| Any comment:                    | According to Step 1.4 of the ACM0006 (Version 12.1.1), all these biomass residue types are used in the power boiler (heat generator), exclusively. As a result, the monitored quantities of biomass residues used in the project will be directly allocated to that heat generator in the baseline scenario. |

|  |  |  |                               |   |   |  |
|--|--|--|-------------------------------|---|---|--|
| Data Unit / Parameter:   | <b>BR<sub>B1/B3,n,y</sub></b>  |  |                               |   |   |  |
| Data unit:   | (Tonnes on dry basis)  |  |                               |   |   |  |
| Description:   | BR <sub>B1/B3,n,y</sub> = Quantity of biomass residues of category n used in the project activity in year y for which the baseline scenario is B1: or B3: (tonnes on dry-basis). |  |                               |   |   |  |
| Source of data:  | On-site measurements.  |  |                               |   |   |  |
| Description of measurement methods and procedures to be applied: | Please see the corresponding section of the parameter: "Biomass residues categories and quantities used in the project activity".  |  |                               |   |   |  |
| Frequency of monitoring/recording:                               | Data monitored continuously and aggregated as appropriate, to calculate emission reductions.   |  |                               |   |   |  |
| Value applied:   | See table below.   |  |                               |   |   |  |
|  | <b>Biomass residue category k</b>  | <b>Biomass residues type</b>                 | <b>Biomass residue source</b> | <b>Biomass residues fate in the absence of the project activity</b> | <b>Biomass residues use in project scenario</b>         | <b>Biomass residues quantity (dry tonnes/yr)</b> |
|  | 2  | Sawdust and bark from industrial operations. | On-site production            | Dumped and/or burned in the open air (B1: and/or B3:).              | Heat and power generation on-site (biomass-only boiler) | 83,786   |
|  | 3  | Sawdust                                      | Off-site                      | Dumped  | Heat and  | 128,052  |

|                                 |  |                                      |                     |  |   |        |
|---------------------------------|--|--------------------------------------|---------------------|--|---|--------|
|                                 |  | and bark from industrial operations. | production          | and/or burned in the open air (B1: and/or B3:).        | power generation on-site (biomass-only boiler)          |        |
|                                 | 4  | Biomass from forestry operations.    | Off-site production | Dumped and/or burned in the open air (B1: and/or B3:). | Heat and power generation on-site (biomass-only boiler) | 35,500 |
| Monitoring equipment:           | See table describing the monitoring equipment procedures under variable "Biomass residues categories and quantities used in the project activity". |                                      |                     |  |   |        |
| QA/QC procedures to be applied: | Crosscheck the measurements with an annual energy balance that is based on purchased quantities and stock changes.                                 |                                      |                     |  |   |        |
| Calculation method:             | Please see the corresponding section of the parameter: "Biomass residues categories and quantities used in the project activity".                  |                                      |                     |  |   |        |
| Any comment:                    | Biogas should be included as appropriate if applicable (in which case convenient units such as m <sup>3</sup> should be used).                     |                                      |                     |  |   |        |

|  |  |
|--|--|
| Data Unit / Parameter:   | <b>BR<sub>B5/B8,n,y</sub></b>  |
| Data unit:   | (Tonnes of dry matter)   |
| Description:   | BR <sub>B5/B8,n,y</sub> = Quantity of biomass residues of category n used in the project activity in year y for which the baseline scenario is B5:, B6:, B7: or B8: (tonnes on dry-basis). |
| Source of data:  | On-site measurements.  |
| Description of measurement methods and procedures to be applied: | Please see the corresponding section of the parameter: "Biomass residues categories and quantities used in the project activity".  |
| Frequency of monitoring/recording:                               | Data monitored continuously and aggregated as appropriate, to calculate emission reductions.   |
| Value applied:   | 0 (tonnes)<br><br>It is not foreseen that these types of biomass   |

|                                 |   |
|---------------------------------|---|
|                                 | residues will be used in the project activity in the future. However, the Project Proponent will include this parameter in the monitoring plan in case the situation changes in the future. |
| Monitoring equipment:           | See table describing the monitoring equipment procedures under variable “Biomass residues categories and quantities used in the project activity”.  |
| QA/QC procedures to be applied: | Crosscheck the measurements with an annual energy balance that is based on purchased quantities and stock changes.  |
| Calculation method:             | Please see the corresponding section of the parameter: “Biomass residues categories and quantities used in the project activity”.   |
| Any comment:                    | Biogas should be included as appropriate if applicable (in which case convenient units such as m <sup>3</sup> should be used).  |

|  |  |
|--|--|
| Data Unit / Parameter:   | $EF_{FF,y,f}$  |
| Data unit:   | (tCO <sub>2</sub> /GJ)   |
| Description:   | $EF_{FF,y,f}$ = CO <sub>2</sub> emission factor for fossil fuel type f in year y (tCO <sub>2</sub> /GJ).   |
| Source of data:  | For the proposed project activity, the selected source is Table 1.4 of Chapter 1 of Vol. 2 (Energy) of the 2006 IPCC Guidelines on National GHG Inventories. To ensure conservativeness, the Project Proponent will use the values at the upper limit of the uncertainty at a 95% confidence interval. |
| Description of measurement methods and procedures to be applied: | Not applicable. The Project Proponent will use IPCC default values.  |
| Frequency of monitoring/recording:                               | The Project Proponent will review the appropriateness of the data annually.  |

|                                 |  |
|---------------------------------|--|
| Value applied:                  | 0.0748 (tCO <sub>2</sub> /GJ) for Diesel.<br><br>0.0788 (tCO <sub>2</sub> /GJ) for Fuel Oil. |
| Monitoring equipment:           | ---  |
| QA/QC procedures to be applied: | Not applicable. The Project Proponent will use IPCC default values.                          |
| Calculation method:             | Not applicable.  |
| Any comment:                    | ---  |

|  |  |
|--|--|
| Data Unit / Parameter:   | <b>EF<sub>CH<sub>4</sub>,BR</sub></b>  |
| Data unit:   | (tCH <sub>4</sub> /GJ)   |
| Description:   | EF <sub>CH<sub>4</sub>,BR</sub> = CH <sub>4</sub> emission factor for the combustion of biomass residues in the project plant (tCH <sub>4</sub> /GJ).  |
| Source of data:  | Default values from the ACM0006 (Version 12.1.1) methodology.  |
| Description of measurement methods and procedures to be applied: | N.A.   |
| Frequency of monitoring/recording:                               | N.A.   |
| Value applied:   | 30 (KgCH <sub>4</sub> /TJ) with an uncertainty conservativeness factor of 1.37 (corresponds to the maximum uncertainty of 300%).<br><br>These values were taken from table 4 and 5 of the ACM0006 (Version 12.1.1.). |
| Monitoring equipment:  | N.A.   |
| QA/QC procedures to be applied:                                  | N.A. since the Project Proponent will use very conservative IPCC default values.   |
| Calculation method:  | Not applicable.  |
| Any comment:   | Monitoring of this parameter for project emissions is required, since in this case CH <sub>4</sub> emissions from  |

|  |  |
|--|--|
|  | <p>biomass combustion are included in the project boundary. A conservative factor will be applied, as specified in the baseline methodology.</p> <p>During 2006, Arauco hired a consultant to conduct measurements of this factor in two similar power boilers (fluidized bed boiler) to the one that will be installed in the Viñales biomass power plant. The results showed that combustion process of the biomass in a modern fluidized bed boiler is so efficient, that the methane concentration in the flue gases is lower than the concentration found in the clean air. In other words, the biomass combustion in this type of boilers reduces the methane concentration of the clean air. As a result, the use of a positive methane emission factor is extremely conservative in this case.</p> |
|--|--|

|  |   |
|--|---|
| Data Unit / Parameter:   | <b>EF<sub>CO<sub>2</sub>,LE</sub></b>   |
| Data unit:   | (tCO <sub>2</sub> /GJ)  |
| Description:   | EF <sub>CO<sub>2</sub>,LE</sub> = CO <sub>2</sub> emission factor of the most carbon intensive fossil fuel used in the country (tCO <sub>2</sub> /GJ).  |
| Source of data:  | Identify the most carbon intensive fuel type from the national communication, other literature sources (e.g. IEA). Possibly consult with the national agency responsible for the national communication / GHG inventory. If available, use national default values for the CO <sub>2</sub> emission factor. Otherwise, IPCC default values may be used. |
| Description of measurement methods and procedures to be applied: | ---   |
| Frequency of monitoring/recording:                               | Annually.   |
| Value applied:   | Not used in this case, since leakage is assumed to be 0.  |
| Monitoring equipment:  | ---   |

|                                 |                 |
|---------------------------------|-----------------|
| QA/QC procedures to be applied: | ---             |
| Calculation method:             | Not applicable. |
| Any comment:                    | ---             |

|  |   |
|--|---|
| Data Unit / Parameter:   | <b>HC<sub>BL,y</sub></b>  |
| Data unit:   | (GJ)  |
| Description:   | HC <sub>BL,y</sub> = Baseline process heat generation in year y (GJ).   |
| Source of data:  | On-site measurements and calculations.  |
| Description of measurement methods and procedures to be applied: | This parameter should be determined as the difference of the enthalpy of the process heat loads in the project activity minus the enthalpy of the feed-water, the boiler blow-down and any condensate return to the heat generators. The respective enthalpies should be determined based on the mass (or volume) flows, the temperatures and, in case of superheated steam, the pressure. Steam tables or appropriate thermodynamic equations may be used to calculate the enthalpy as a function of temperature and pressure. |
| Frequency of monitoring/recording:                               | Calculated based on continuously monitored data and aggregated as appropriate, to calculate emission reductions.  |
| Value applied:   | 1,028,677 (GJ/yr)   |
| Monitoring equipment:  | Equipment type: Pressure gauge transmitter<br>Power Boiler. High pressure line<br>TAG: 663-PT-0155<br>Brand: Endress & Hauser<br>Model: Cerabar S // PMP75-ACC1WB1UBGAU<br>Serial number: D 500 C 90109 C<br>Measurement range: 0 - 120 BAR(G)<br>Accuracy: ±0.075%   |

|  |   |
|--|---|
|  | <p>Equipment type: Flow transmitter Power Boiler.<br/>High pressure line<br/>TAG: 663-FT-0156<br/>Brand: Endress &amp; Hauser<br/>Model: Cerabar S // PMD75-ACC7FB1DAVU-DA63M-AB2BBD<br/>Serial number: D501F50109D<br/>Measurement range: 0 – 200 " H<sub>2</sub>O<br/>Accuracy: ±0.075%</p> |
|  | <p>Equipment type: Temperature transmitter Power Boiler. High pressure line.<br/>TAG: 663-TT-0157<br/>Brand: Endress &amp; Hauser<br/>Model: TH53-8A23E2E2B31AK<br/>Serial number: 266161<br/>Measurement range: 0 – 600 °C<br/>Accuracy: ≤±0.05%</p>   |
|  | <p>Equipment type: Pressure gauge transmitter high pressure line.<br/>TAG: 665-PT-9040-A/665-PT-9040-B<br/>Brand: Rosemount<br/>Model: 2051TG4A2B21AB4Q4<br/>Serial number: 32601 (A) – 32602 (B)<br/>Measurement range: 0 – 140 bar (G)<br/>Accuracy: ±0.05%</p>                             |
|  | <p>Equipment type: Flow transmitter high pressure line.<br/>TAG: 665-FT-9030<br/>Brand: Rosemount<br/>Model: 2051CD2F02A1A55Q4<br/>Serial number: 33712<br/>Measurement range: 0 – 200 " H<sub>2</sub>O<br/>Accuracy: ±0.05%</p>  |
|  | <p>Equipment type: Temperature transmitter high pressure line<br/>TAG: 665-TT-9043 A/665-TT-9043 B<br/>Brand: Rosemount</p>   |

|  |   |
|--|---|
|  | <p>Model: 644HANAJ6Q4<br/>         Serial number: 0271902 (A) – 0219846 (B)<br/>         Measurement range: 0 – 650 °C<br/>         Accuracy: ±0.05%</p> <p>Equipment type: Pressure gauge transmitter medium pressure line.<br/>         TAG: 665-PT-9001 A/665-PT-9001 B<br/>         Brand: Rosemount<br/>         Model: 2051TG3F2B21AB4Q4<br/>         Serial number: 32561 (A) – 32562 (B)<br/>         Measurement range: 0 – 18 bar (G)<br/>         Accuracy: ±0.05%</p> <p>Equipment type: Flow transmitter medium pressure line<br/>         TAG: 665-FT-9025<br/>         Brand: Rosemount<br/>         Model: 2051CD2F02A1AS5Q4<br/>         Serial number: 33711<br/>         Measurement range: 0 – 45.564 ton/h<br/>         Accuracy: ±0.05%</p> <p>Equipment type: Flow transmitter medium pressure line<br/>         TAG: 665-FT-9051<br/>         Brand: Rosemount<br/>         Model: 2051CD2F02A1AS5Q4<br/>         Serial number: 107763<br/>         Measurement range: 0 – 40 ton/h<br/>         Accuracy: ±0.05%</p> <p>Equipment type: Temperature transmitter medium pressure line<br/>         TAG: 665-TT-9026<br/>         Brand: Rosemount<br/>         Model: 644HFNAJ6Q4<br/>         Serial number: 0271897<br/>         Measurement range: 0-450°C<br/>         Accuracy: ±0.15°C</p> |
|--|---|

|  |  |
|--|--|
|  | <p>Equipment type: Pressure gauge transmitter low pressure line<br/>                 TAG: 665-PT-9002 A/665-PT-9002 B/665-PT-9002 C<br/>                 Brand: Rosemount<br/>                 Model: 2051TG2A2B21AB4Q4<br/>                 Serial number: 32598 (A) – 32599 (B) – 32600 (C)<br/>                 Measurement range: 0 – 10 bar (G)<br/>                 Accuracy: ±0.05%</p> |
|  | <p>Equipment type: Flow transmitter low pressure line<br/>                 TAG: 665-FT-9019<br/>                 Brand: Rosemount<br/>                 Model: 2051CD2F02A1AS5Q4<br/>                 Serial number: 33709<br/>                 Measurement range: 0 – 30 ton/h<br/>                 Accuracy: ±0.05%</p>   |
|  | <p>Equipment type: Deaerator steam flow transmitter<br/>                 TAG: 665-FT-9023<br/>                 Brand: Rosemount<br/>                 Model: 2051CD2F02A1AS5Q4<br/>                 Serial number: 33710<br/>                 Measurement range: 0 – 60 ton/h<br/>                 Accuracy: ±0.05%</p>   |
|  | <p>Equipment type: Temperature transmitter low pressure line<br/>                 TAG: 665-TT-9024<br/>                 Brand: Rosemount<br/>                 Model: 644HFNAJ6Q4<br/>                 Serial number: 0271896<br/>                 Measurement range: 0-450°C<br/>                 Accuracy: ±0.15°C</p>  |
|  | <p>Equipment type: Feed water pressure gauge transmitter<br/>                 TAG: 663-PT-0106<br/>                 Brand: Endress &amp; Hauser</p>  |

|                                 |   |
|---------------------------------|---|
|                                 | <p>Model: PMD75-ARC7FB1DAVU<br/>         Serial number: D501E40109D<br/>         Measurement range: 0-100 " H<sub>2</sub>O<br/>         Accuracy: ±0.075%</p> <p>Equipment type: Feed water temperature transmitter<br/>         TAG: 663-TT-0111<br/>         Brand: Rosemount<br/>         Model: 644HFNAJ6Q4<br/>         Serial number: 265913<br/>         Measurement range: 0-200°C<br/>         Accuracy: ±0.15°C</p> |
| QA/QC procedures to be applied: | ---   |
| Calculation method:             | N.A.  |
| Any comment:                    | ---   |

|  |  |
|--|--|
| Data Unit / Parameter:   | <b>EL<sub>PJ, gross, y</sub></b>   |
| Data unit:   | (MWh)  |
| Description:   | EL <sub>PJ, gross, y</sub> = Gross quantity of electricity generated in all power plants which are located at the project site and included in the project boundary in year y (MWh).   |
| Source of data:  | On-site measurements.  |
| Description of measurement methods and procedures to be applied: | Use calibrated electricity meters.   |
| Frequency of monitoring/recording:                               | Data monitored continuously and aggregated as appropriate, to calculate emission reductions.   |
| Value applied:   | 325,464 (MWh/yr)   |
| Monitoring equipment:  | <p>Power generation is measured by an on-line meter. The measured values are integrated and stored in the power plant's Delta V DCS system.</p> <p>Gross energy generated<br/>         TAG: 8600-10<br/>         Brand: Schneider Electric</p> |

|                                 |  |
|---------------------------------|--|
|                                 | <p>Model: Ion 8600</p> <p>Serial number: LT-1012A701-01</p> <p>Accuracy: <math>\pm 0.2\%</math></p> <p>Calibration frequency: Once every 7 years.</p> <p>Calibration date: December 24<sup>th</sup>, 2010.</p>   |
| QA/QC procedures to be applied: | <p>The consistency of metered electricity generation should be cross-checked with:</p> <ul style="list-style-type: none"> <li>- Monthly rate between receipts from electricity sales (if available) and the calculated displacement of the grid is within a range comparable to transmission losses.</li> <li>- Indicator between the electricity generation divided by the quantity of combusted biomass in Power boiler (e.g. check whether results in a reasonable efficiency that is comparable to previous years).</li> <li>- Measured energy displacement using dedicated equipment must be comparable to calculated energy displacement according methodology.</li> </ul> |
| Calculation method:             | N.A.   |
| Any comment:                    | <p>Calculated Energy displacement from the grid =<br/> Gross quantity electricity generated in power plant + Project electricity imports from the grid -<br/> Total auxiliary electricity consumption for power plant operation.</p> <p>Measured energy displacement = Grid energy export + Sawmill energy consumption.</p>  |

|  |  |
|--|--|
| Data Unit / Parameter:   | <b>EL<sub>PJ,imp,y</sub></b>   |
| Data unit:   | (MWh)  |
| Description:   | EL <sub>PJ,imp,y</sub> = Project electricity imports from the grid in year y (MWh).          |
| Source of data:  | On-site measurements.  |
| Description of measurement methods and procedures to be applied: | Use calibrated electricity meters.   |
| Frequency of monitoring/recording:                               | Data monitored continuously and aggregated as appropriate, to calculate emission reductions. |
| Value applied:   | 1,500 (MWh/yr)   |

|  |  |
|--|--|
| <p>Monitoring equipment:</p>           | <p>Power imports to project are usually expected during plant failure or plant maintenance. Total power imports will be measured by an on-line power meter and the measured values will be integrated and recorded in the power plant's DCS system.</p> <p>Import electricity to Viñales Complex<br/>TAG: SE-EI-0006/0007 (52-B1)<br/>Brand: Schneider Electric<br/>Model: Ion 8600<br/>Serial number: PT-1012A934-01<br/>Accuracy: ±0.2%<br/>Calibration frequency: According to the manufacturer, no calibration is required in this case.<br/>Factory calibration: June 6<sup>th</sup>, 2011.</p> <p>Electricity consumption in Viñales Sawmill<br/>TAG: 8600-2_3<br/>Brans: Schneider Electric<br/>Model: Ion 8600<br/>Serial number: MT-1010A242-01<br/>Accuracy: ±0.2%<br/>Calibration frequency: 7 years<br/>Factory calibration: October, 9<sup>th</sup>, 2010</p> |
| <p>QA/QC procedures to be applied:</p> | <p>The consistency of metered electricity generation should be cross-checked with:</p> <ul style="list-style-type: none"> <li>- Percentage difference between Total electricity import and receipts from electricity purchases (if available)</li> <li>- Indicator between the electricity generation divided by the quantity of combusted biomass in Power boiler (e.g. check whether results in a reasonable efficiency that is comparable to previous years).</li> </ul>  |
| <p>Calculation method:</p>             | <p>Equipment TAG SE-EI-0006/0007 (52-B1) measure the Total electricity import to Viñales complex (Power plant + Sawmill) then:</p>   |

|              |  |
|--------------|--|
|              | <p>- Project electricity imports are equal to zero when Available power generation is more or equal to Viñales sawmill energy process demand.</p> <p>- Project electricity imports are more than zero when Available power generation is less than Viñales sawmill energy process demand:</p> <p>Project electricity imports = Available power generation + Total electricity import - Electricity import to Viñales sawmill process from the grid</p> |
| Any comment: | <p>Total electricity import = Project electricity import from the grid + Electricity import to Viñales sawmill process from the grid.</p> <p>Available power generation = Gross quantity electricity generated in power plant - export surplus electricity to the grid – Internal Transmission losses before Grid injection.</p>   |

|  |  |
|--|--|
| Data Unit / Parameter:   | <b>EL<sub>PJ,aux,y</sub></b>   |
| Data unit:   | (MWh)  |
| Description:   | EL <sub>PJ,aux,y</sub> = Total auxiliary electricity consumption required for the operation of the power plants at the project site in year y (MWh).   |
| Source of data:  | On-site measurements and calculations.   |
| Description of measurement methods and procedures to be applied: | Use calibrated electricity meters and conservative calculations.   |
| Frequency of monitoring/recording:                               | Data monitored continuously and aggregated as appropriate, to calculate emission reductions.   |
| Value applied:   | 35,784 (MWh/yr)  |
| Monitoring equipment:  | <p>Total auxiliary electricity consumption</p> <p>Viñales_1_6_Manejo_Desechos_Comb</p> <p>TAG: 669-EI-1603/1604 (1-6)</p> <p>Brand: Schneider Electric</p> <p>Model: Ion 7550</p> <p>Serial number: LI-1010A261-02</p> <p>Accuracy: +/- 0.2%</p> <p>Calibration date: October 12, 2010</p> |

|  |   |
|--|---|
|  | <p>Calibration frequency: According to the manufacturer, no calibration is required in this case.</p> <p>Viñales_1_7_CP_Caldera_Poder<br/>TAG: 669-EI-1703/1704 (1-7)<br/>Brand: Schneider Electric<br/>Model: Ion 7550<br/>Serial number: LI-1010A263-02<br/>Accuracy class: +/- 0.2%<br/>Calibration date: October 12, 2010<br/>Calibration frequency: According to the manufacturer, no calibration is required in this case.</p> <p>Viñales_1_8_CP_Caldera_Poder<br/>TAG: 669-EI_1803/1804 (1-8)<br/>Brand: Schneider Electric<br/>Model: Ion 7550<br/>Serial number: LI-1010A264-02<br/>Accuracy class: +/- 0.2%<br/>Calibration date: October 12, 2010<br/>Calibration frequency: According to the manufacturer, no calibration is required in this case.</p> <p>Viñales_1_9_CP_Caldera_Poder<br/>TAG: 669-EI-1903/1904 (1-9)<br/>Brand: Schneider Electric<br/>Model: Ion 7550<br/>Serial number: LI-1010A262-02<br/>Accuracy: +/- 0.2%<br/>Calibration date: October 14<sup>th</sup>, 2010<br/>Calibration frequency: According to the manufacturer, no calibration is required in this case.</p> <p>Viñales_1_11_Barra_1B_Ed_Administración<br/>TAG: 669-EI-1703/1804 (1-11)<br/>Brand: Schneider Electric<br/>Model: Ion 7550</p> |
|--|---|

|  |  |
|--|--|
|  | <p>Serial number: LI-1010A265-02</p> <p>Accuracy: +/- 0.2%</p> <p>Calibration date: October 12, 2012</p> <p>Calibration frequency: According to the manufacturer, no calibration is required in this case.</p>   |
| <p>QA/QC procedures to be applied:</p> | <p>The consistency of metered electricity generation should be cross-checked with:</p> <ul style="list-style-type: none"> <li>- Percentage difference between the export surplus electricity to the grid plus sawmill consumption electricity with receipts from electricity sales (if available) are comparable to transmission losses.</li> <li>- Indicator between the electricity generation divided by the quantity of combusted biomass in Power boiler (e.g. check whether results in a reasonable efficiency that is comparable to previous years).</li> <li>- Measured energy displacement using dedicated equipment must be comparable to calculated energy displacement according methodology.</li> </ul>   |
| <p>Calculation method:</p>             | <p>This parameter will be measured except for the equipment associated to the pneumatic transportation system, that carries the biomass residues from sawmill and the remanufacture plants to the Viñales biomass power plant (the consumption is too small). Since these electricity consumptions must also be accounted for, the Project Proponent will make a very conservative assumption to determine this consumption:</p> <p>According to the equipment specifications, their maximum possible electric power consumption are as follows:</p> <p><u>1 Blowing line for the Sawmill</u></p> <ul style="list-style-type: none"> <li>• Rotatory valve: 4 KW</li> <li>• Blower: 75 KW</li> </ul> <p><u>2 Blowing lines for the Remanufacture plant</u></p> <ul style="list-style-type: none"> <li>• Rotatory valve: 5.5 KW</li> <li>• Blower N°1: 132 KW</li> <li>• Blower N°2: 132 KW</li> </ul> |

|              |  |
|--------------|--|
|              | <p>Total maximum power consumption: 348.5 KW.</p> <p>This value will be used to calculate the maximum electricity consumption per year associated to these equipment:</p> $348.5 \text{ KW} * 8,760 \text{ hr/yr} / (1000,000 \text{ KWh/GWh}) = \mathbf{3.05 \text{ GWh/yr.}}$ <p>This result will be added to the total auxiliary electric power consumption measured in the Viñales power plant.</p>  |
| Any comment: | <p>EL<sub>PJ,aux,y</sub> shall include all electricity required for the operation of equipment related to the preparation, storage and transport of biomass residues (e.g. for mechanical treatment of the biomass, conveyor belts, driers, etc.) and electricity required for the operation of all power plants which are located at the project site and included in the project boundary (e.g. for pumps, fans, cooling towers, instrumentation and control, etc.). In case steam turbines are used for mechanical power in the baseline situation and electric motors for the same purpose in the project situation, the electricity used to run these electric motors shall be included in EL<sub>PJ,aux,y</sub>.</p> <p>In the case of the Viñales project, EL<sub>PJ,aux,y</sub>. will include the electric consumption of:</p> <ul style="list-style-type: none"> <li>• Power boiler</li> <li>• Cooling towers</li> <li>• Turbine plant</li> <li>• Water sourcing and treatment</li> <li>• Biomass handling</li> </ul> |

|                        |   |
|------------------------|---|
| Data Unit / Parameter: | <b>NCV<sub>BR,n,y</sub></b>   |
| Data unit:             | (GJ/tonnes of dry matter)   |
| Description:           | NCV <sub>BR,n,y</sub> = Net calorific value of biomass residue of category n in year y (GJ/tonne on dry-basis). |

| Source of data:  | On-site measurements.   |                            |                         |                        |                         |   |  |                    |      |   |  |                    |      |   |  |                     |      |   |                                   |                     |      |
|--|---|----------------------------|-------------------------|------------------------|-------------------------|---|--|--------------------|------|---|--|--------------------|------|---|--|---------------------|------|---|-----------------------------------|---------------------|------|
| Description of measurement methods and procedures to be applied: | Measurements shall be carried out at reputed laboratories and according to relevant international standards. Measure the NCV on dry-basis.  |                            |                         |                        |                         |   |  |                    |      |   |  |                    |      |   |  |                     |      |   |                                   |                     |      |
| Frequency of monitoring/recording:                               | At least every six months, taking at least three samples for each measurement.  |                            |                         |                        |                         |   |  |                    |      |   |  |                    |      |   |  |                     |      |   |                                   |                     |      |
| Value applied:   | <table border="1"> <thead> <tr> <th>Biomass residue category k</th> <th>Biomass residues type</th> <th>Biomass residue source</th> <th>NCV (GJ/ton-dry matter)</th> </tr> </thead> <tbody> <tr> <td>1</td> <td>Sawdust and bark from industrial operations.</td> <td>On-site production</td> <td>18.5</td> </tr> <tr> <td>2</td> <td>Sawdust and bark from industrial operations.</td> <td>On-site production</td> <td>18.5</td> </tr> <tr> <td>3</td> <td>Sawdust and bark from industrial operations.</td> <td>Off-site production</td> <td>18.5</td> </tr> <tr> <td>4</td> <td>Biomass from forestry operations.</td> <td>Off-site production</td> <td>18.5</td> </tr> </tbody> </table> | Biomass residue category k | Biomass residues type   | Biomass residue source | NCV (GJ/ton-dry matter) | 1 | Sawdust and bark from industrial operations. | On-site production | 18.5 | 2 | Sawdust and bark from industrial operations. | On-site production | 18.5 | 3 | Sawdust and bark from industrial operations. | Off-site production | 18.5 | 4 | Biomass from forestry operations. | Off-site production | 18.5 |
| Biomass residue category k                                       | Biomass residues type   | Biomass residue source     | NCV (GJ/ton-dry matter) |                        |                         |   |  |                    |      |   |  |                    |      |   |  |                     |      |   |                                   |                     |      |
| 1  | Sawdust and bark from industrial operations.  | On-site production         | 18.5                    |                        |                         |   |  |                    |      |   |  |                    |      |   |  |                     |      |   |                                   |                     |      |
| 2  | Sawdust and bark from industrial operations.  | On-site production         | 18.5                    |                        |                         |   |  |                    |      |   |  |                    |      |   |  |                     |      |   |                                   |                     |      |
| 3  | Sawdust and bark from industrial operations.  | Off-site production        | 18.5                    |                        |                         |   |  |                    |      |   |  |                    |      |   |  |                     |      |   |                                   |                     |      |
| 4  | Biomass from forestry operations.   | Off-site production        | 18.5                    |                        |                         |   |  |                    |      |   |  |                    |      |   |  |                     |      |   |                                   |                     |      |
| Monitoring equipment:  | Not applicable. Net calorific values will be measured locally, in reputed laboratories.   |                            |                         |                        |                         |   |  |                    |      |   |  |                    |      |   |  |                     |      |   |                                   |                     |      |
| QA/QC procedures to be applied:                                  | Check the consistency of the measurements by comparing the measurement results with measurements from previous years, relevant data sources (e.g. values in the literature, values used in the national GHG inventory) and default values by the IPCC. If the measurement results differ significantly from previous measurements or other relevant data sources, conduct additional measurements. Ensure that the NCV is determined on the basis of dry biomass.   |                            |                         |                        |                         |   |  |                    |      |   |  |                    |      |   |  |                     |      |   |                                   |                     |      |
| Calculation method:  | Not applicable.   |                            |                         |                        |                         |   |  |                    |      |   |  |                    |      |   |  |                     |      |   |                                   |                     |      |
| Any comment:   | Biogas should be included as appropriate if applicable (in which case convenient units such as GJ/m <sup>3</sup> should be used).   |                            |                         |                        |                         |   |  |                    |      |   |  |                    |      |   |  |                     |      |   |                                   |                     |      |

| Data Unit / Parameter:   | <b>Moisture content of the biomass residues</b>   |                                   |                                |                        |                                |   |  |                    |     |   |  |                    |     |   |  |                     |     |   |                                   |                     |     |
|--|---|-----------------------------------|--------------------------------|------------------------|--------------------------------|---|--|--------------------|-----|---|--|--------------------|-----|---|--|---------------------|-----|---|-----------------------------------|---------------------|-----|
| Data unit:   | % Water content in mass basis in wet biomass residues.  |                                   |                                |                        |                                |   |  |                    |     |   |  |                    |     |   |  |                     |     |   |                                   |                     |     |
| Description:   | Moisture content of each biomass residues type <i>k</i> .   |                                   |                                |                        |                                |   |  |                    |     |   |  |                    |     |   |  |                     |     |   |                                   |                     |     |
| Source of data:  | On-site measurements.   |                                   |                                |                        |                                |   |  |                    |     |   |  |                    |     |   |  |                     |     |   |                                   |                     |     |
| Description of measurement methods and procedures to be applied: | The biomass residue moisture content will be monitored and registered by taking periodic samples from each biomass type flow to the power boiler. Humidity content will be calculated by evaporating the water of the samples and measuring the weight before and after the water has been evaporated. This process will be carried out in dedicated scales.  |                                   |                                |                        |                                |   |  |                    |     |   |  |                    |     |   |  |                     |     |   |                                   |                     |     |
| Frequency of monitoring/recording:                               | The moisture content should be monitored for each batch of biomass of homogeneous quality. The weighted average should be calculated for each monitoring period and used in the calculations.   |                                   |                                |                        |                                |   |  |                    |     |   |  |                    |     |   |  |                     |     |   |                                   |                     |     |
| Value applied:   | <table border="1"> <thead> <tr> <th>Biomass residue category <i>k</i></th> <th>Biomass residues type</th> <th>Biomass residue source</th> <th>Moisture content (% wet basis)</th> </tr> </thead> <tbody> <tr> <td>1</td> <td>Sawdust and bark from industrial operations.</td> <td>On-site production</td> <td>50%</td> </tr> <tr> <td>2</td> <td>Sawdust and bark from industrial operations.</td> <td>On-site production</td> <td>50%</td> </tr> <tr> <td>3</td> <td>Sawdust and bark from industrial operations.</td> <td>Off-site production</td> <td>50%</td> </tr> <tr> <td>4</td> <td>Biomass from forestry operations.</td> <td>Off-site production</td> <td>50%</td> </tr> </tbody> </table> | Biomass residue category <i>k</i> | Biomass residues type          | Biomass residue source | Moisture content (% wet basis) | 1 | Sawdust and bark from industrial operations. | On-site production | 50% | 2 | Sawdust and bark from industrial operations. | On-site production | 50% | 3 | Sawdust and bark from industrial operations. | Off-site production | 50% | 4 | Biomass from forestry operations. | Off-site production | 50% |
| Biomass residue category <i>k</i>                                | Biomass residues type   | Biomass residue source            | Moisture content (% wet basis) |                        |                                |   |  |                    |     |   |  |                    |     |   |  |                     |     |   |                                   |                     |     |
| 1  | Sawdust and bark from industrial operations.  | On-site production                | 50%                            |                        |                                |   |  |                    |     |   |  |                    |     |   |  |                     |     |   |                                   |                     |     |
| 2  | Sawdust and bark from industrial operations.  | On-site production                | 50%                            |                        |                                |   |  |                    |     |   |  |                    |     |   |  |                     |     |   |                                   |                     |     |
| 3  | Sawdust and bark from industrial operations.  | Off-site production               | 50%                            |                        |                                |   |  |                    |     |   |  |                    |     |   |  |                     |     |   |                                   |                     |     |
| 4  | Biomass from forestry operations.   | Off-site production               | 50%                            |                        |                                |   |  |                    |     |   |  |                    |     |   |  |                     |     |   |                                   |                     |     |
| Monitoring equipment:  | <p>The laboratory in which the biomass residues moisture content will be measured will count with the following equipment:</p> <p>Equipment type: Digital weight meter<br/> Brand: Sartorius<br/> Model: TE1502S<br/> Serial number: 27402265</p>   |                                   |                                |                        |                                |   |  |                    |     |   |  |                    |     |   |  |                     |     |   |                                   |                     |     |

|                                 |  |
|---------------------------------|--|
|                                 | <p>Measurement range: 0 – 1500 gr</p> <p>Equipment type: Oven<br/>Brand: MEMMERT<br/>Model: UFE 600<br/>Serial Number: G611.0831<br/>Measurement range: 30 – 250 °C</p> <p>Equipment type: Electronic moisture analyser<br/>Brand: Sartorius<br/>Model: MA 150C<br/>Serial Number: 27008246<br/>Measurement range: 40 – 180 °C</p> |
| QA/QC procedures to be applied: | ---  |
| Calculation method:             | <p>Moisture content is determined using the following equation:</p> $\text{Moisture content, biomass type } i \text{ (\%)} = [(S_w - S_d)/S_w] * 100$ <p>Where:<br/>S<sub>w</sub>: Wet biomass residue type i sample weight.<br/>S<sub>d</sub>: Bone-dry biomass residue type i weight.</p>  |
| Any comment:                    | ---  |

|  |  |
|--|--|
| Data Unit / Parameter:   | <b>P<sub>y</sub></b>   |
| Data unit:   | Use suitable units, as appropriate.  |
| Description:   | P <sub>y</sub> = Quantity of the main product of the production process (e.g. sugar cane, rice) produced in year y from plants operated at the project site. |
| Source of data:  | On-site measurements.  |
| Description of measurement methods and procedures to be applied: | ---  |
| Frequency of monitoring/recording:                               | Data aggregated as appropriate, to calculate emissions reductions.   |

|                                 |  |
|---------------------------------|--|
| Value applied:                  | <ul style="list-style-type: none"> <li>• 352,686 m<sup>3</sup>/yr of sawn timber from the sawmill.</li> <li>• 88,203 m<sup>3</sup>/yr of processed wood products from the remanufacture plant.</li> </ul> <p>These production levels correspond to the averages between the productions of 2012 and 2013 respectively. Production levels might vary from year to year, depending on market conditions.</p> |
| Monitoring equipment:           | N.A.   |
| QA/QC procedures to be applied: | ---  |
| Calculation method:             | Not applicable.  |
| Any comment:                    | ---  |

|  |   |
|--|---|
| Data Unit / Parameter:   | <b>LOC<sub>y</sub></b>  |
| Data unit:   | Hour.   |
| Description:   | LOC <sub>y</sub> = Length of the operational campaign in year y (hour).                 |
| Source of data:  | On-site measurements.   |
| Description of measurement methods and procedures to be applied: | Record and sum the hours of operation of the project activity facilities during year y. |
| Frequency of monitoring/recording:                               | ---   |
| Value applied:   | 8,520 hours.  |
| Monitoring equipment:  | ---   |
| QA/QC procedures to be applied:                                  | ---   |
| Calculation method:  | Not applicable.   |

|              |  |
|--------------|--|
| Any comment: | This estimation is based on the total available hours per month in a year, considering maintenance outages both for internal and external reasons. As a result, the yearly operating plan considers approximately 10 days of the power plant outage in a year. |
|--------------|--|

**Data and parameters monitored from the tool: “Tool to calculate project or leakage CO<sub>2</sub> emissions from fossil fuel combustion” (Version 02)**

|  |  |
|--|--|
| Data Unit / Parameter:   | <b>FC<sub>i,j,y</sub></b>  |
| Data unit:   | Mass or volume unit per year (e.g. ton/yr or m <sup>3</sup> /yr).  |
| Description:   | Quantity of fuel type i combusted in process j during the year y.  |
| Source of data:  | On-site measurements.  |
| Description of measurement methods and procedures to be applied: | On-site fossil fuel consumption will be calculated in this case. Please see the calculation section of this parameter.   |
| Frequency of monitoring/recording:                               | Continuously.  |
| Value applied:   | <ul style="list-style-type: none"> <li>• Diesel consumption in the power boiler due to operational reasons: 50 ton/yr.</li> <li>• Diesel consumption due to on-site biomass transportation from the gate to the power boiler conveyor belts: 7,438 lt/yr.</li> <li>• Diesel consumption of the front-loaders: 77,760 lt/yr.</li> </ul> |
| Monitoring equipment:  | <p><u>Diesel consumption in the power boiler:</u> The consumption will be determined by dedicated fuel flow meters.</p> <p>663FT-508</p> <p>Type: Fossil fuel flow transmitter.</p> <p>Endress+Hausser 83F40-AABSAAACBAAK</p> <p>Accuracy class: +/- 0.1%</p>  |

|  |   |
|--|---|
|  | <p>Serial number: D606EA16000</p> <p>663FT-522</p> <p>Type: Fossil fuel flow transmitter.</p> <p>Endress+Hausser 33F25-AABSAAACBAAK</p> <p>Accuracy class: +/- 0.5%</p> <p>Serial number: D606E916000</p>   |
| <p>QA/QC procedures to be applied:</p> | <p>The consistency of metered fuel consumption quantities should be cross-checked by an annual energy balance that is based on purchased quantities and stock changes.</p> <p>Where the purchased fuel invoices can be identified specifically for the emission reduction project, the metered fuel consumption quantities should also be cross-checked with available purchase invoices from the financial records.</p>  |
| <p>Calculation method:</p>             | <p><u>Diesel consumption due to on-site biomass transportation:</u></p> <p><u>Transportation of biomass residues from the gate to the power plant:</u> The Project Proponent will obtain the specific diesel consumption (km/lt of diesel) for all the trucks transporting the biomass residues on-site. In addition, the Project Proponent will also determine the distances travelled by the trucks on-site. The total amount of diesel consumed by each truck will be determined by dividing the total distance travelled on-site by the corresponding specific consumption. The total amount of diesel consumed due to on-site biomass transportation will be the sum of all the diesel amounts consumed by all the trucks used for on-site biomass transportation.</p> <p><u>Diesel consumption of the front loaders:</u> The calculation is similar to the one described above. However, in this case, the Project Proponent will use the diesel performance index expressed in litres of diesel consumption per hour of operation of the front loader. The Project Proponent will choose a conservative diesel performance index</p> |

|              |   |
|--------------|---|
|              | for the emission reduction calculation for the period. The total diesel consumption will be determined by multiplying the diesel consumption index of the front loader by the total amount of hours of operation of the front loader. |
| Any comment: | ---   |

| Data Unit / Parameter:  | <b>NCV<sub>i,y</sub></b>   |             |                                      |  |   |  |                         |   |   |   |                         |
|---|--|-------------|--------------------------------------|--|---|--|-------------------------|---|---|---|-------------------------|
| Data unit:  | GJ per mass or volume unit (e.g. GJ/m <sup>3</sup> , GJ/ton)   |             |                                      |  |   |  |                         |   |   |   |                         |
| Description:  | Weighted average net calorific value of fuel type i in year y.   |             |                                      |  |   |  |                         |   |   |   |                         |
| Source of data:   | <p>The following data sources may be used in the relevant conditions apply:</p> <table border="1"> <thead> <tr> <th>Data source</th> <th>Conditions for using the data source</th> </tr> </thead> <tbody> <tr> <td>a) Values provided by the fuel supplier in invoices.</td> <td>This is the preferred source if the carbon fraction of the fuel is not provided (Option A).</td> </tr> <tr> <td>b) Measurements by the project participants.</td> <td>If a) is not available.</td> </tr> <tr> <td>c) Regional or national default values.</td> <td>If a) is not available.<br/><br/>These sources can only be used for liquid fuels and should be based on well documented, reliable sources (such as national energy balances).</td> </tr> <tr> <td>d) IPCC default values at the upper limit of the uncertainty at a 95% confidence interval as provided in Table 1.2 of Chapter 1 of Vol. 2 (Energy) of the 2006 IPCC Guidelines on National GHG Inventories.</td> <td>If a) is not available.</td> </tr> </tbody> </table> <p>For the proposed project, the selected source is the one provided in option d) of the table above: the IPCC default values at the upper limit of the uncertainty at a 95% confidence interval as provided in Table 1.2 of Chapter 1 of Vol. 2</p> | Data source | Conditions for using the data source | a) Values provided by the fuel supplier in invoices. | This is the preferred source if the carbon fraction of the fuel is not provided (Option A). | b) Measurements by the project participants. | If a) is not available. | c) Regional or national default values. | If a) is not available.<br><br>These sources can only be used for liquid fuels and should be based on well documented, reliable sources (such as national energy balances). | d) IPCC default values at the upper limit of the uncertainty at a 95% confidence interval as provided in Table 1.2 of Chapter 1 of Vol. 2 (Energy) of the 2006 IPCC Guidelines on National GHG Inventories. | If a) is not available. |
| Data source   | Conditions for using the data source   |             |                                      |  |   |  |                         |   |   |   |                         |
| a) Values provided by the fuel supplier in invoices.  | This is the preferred source if the carbon fraction of the fuel is not provided (Option A).  |             |                                      |  |   |  |                         |   |   |   |                         |
| b) Measurements by the project participants.  | If a) is not available.  |             |                                      |  |   |  |                         |   |   |   |                         |
| c) Regional or national default values.   | If a) is not available.<br><br>These sources can only be used for liquid fuels and should be based on well documented, reliable sources (such as national energy balances).  |             |                                      |  |   |  |                         |   |   |   |                         |
| d) IPCC default values at the upper limit of the uncertainty at a 95% confidence interval as provided in Table 1.2 of Chapter 1 of Vol. 2 (Energy) of the 2006 IPCC Guidelines on National GHG Inventories. | If a) is not available.  |             |                                      |  |   |  |                         |   |   |   |                         |

|  |   |
|--|---|
|  | (Energy) of the 2006 IPCC Guidelines.   |
| Description of measurement methods and procedures to be applied: | Not applicable, since the Project Proponent will use option d) (IPCC default values) in this case.        |
| Frequency of monitoring/recording:                               | For option d): Any future revision of the IPCC Guidelines should be taken into account.                   |
| Value applied:   | <ul style="list-style-type: none"> <li>• Diesel: 43.3 GJ/ton</li> <li>• Fuel oil: 41.7 GJ/ton.</li> </ul> |
| Monitoring equipment:  | Not applicable, since the Project Proponent will use option d) (IPCC default values) in this case.        |
| QA/QC procedures to be applied:                                  | Not applicable, since the Project Proponent will use option d) (IPCC default values) in this case.        |
| Calculation method:  | Not applicable in this case.  |
| Any comment:   | Applicable where Option B is used.  |

| Data Unit / Parameter:                               | <b>EF<sub>CO<sub>2</sub>,i</sub></b>  |             |                                      |  |                               |  |                         |   |                         |
|--|---|-------------|--------------------------------------|--|-------------------------------|--|-------------------------|---|-------------------------|
| Data unit:   | (tCO <sub>2</sub> /GJ).   |             |                                      |  |                               |  |                         |   |                         |
| Description:   | Weighted average CO <sub>2</sub> emission factor of fuel type i in year y.  |             |                                      |  |                               |  |                         |   |                         |
| Source of data:                                      | <p>The following data sources may be used if the relevant conditions apply:</p> <table border="1"> <thead> <tr> <th>Data source</th> <th>Conditions for using the data source</th> </tr> </thead> <tbody> <tr> <td>a) Values provided by the fuel supplier in invoices.</td> <td>This is the preferred source.</td> </tr> <tr> <td>b) Measurements by the project participants.</td> <td>If a) is not available.</td> </tr> <tr> <td>c) Regional or national default values.</td> <td>If a) is not available.</td> </tr> </tbody> </table> <p>These sources can only be used for liquid fuels and should be based on well documented, reliable sources (such as</p> | Data source | Conditions for using the data source | a) Values provided by the fuel supplier in invoices. | This is the preferred source. | b) Measurements by the project participants. | If a) is not available. | c) Regional or national default values. | If a) is not available. |
| Data source  | Conditions for using the data source  |             |                                      |  |                               |  |                         |   |                         |
| a) Values provided by the fuel supplier in invoices. | This is the preferred source.   |             |                                      |  |                               |  |                         |   |                         |
| b) Measurements by the project participants.         | If a) is not available.   |             |                                      |  |                               |  |                         |   |                         |
| c) Regional or national default values.              | If a) is not available.   |             |                                      |  |                               |  |                         |   |                         |

|  |   |                            |
|--|---|----------------------------|
|  |   | national energy balances). |
|  | d) IPCC default values at the upper limit of the uncertainty at a 95% confidence interval as provided in Table 1.4 of Chapter 1 of Vol. 2 (Energy) of the 2006 IPCC Guidelines on National GHG Inventories.   | If a) is not available.    |
|  | For the proposed project, the selected source is the one provided in option d) of the table above: the IPCC default values at the upper limit of the uncertainty at a 95% confidence interval as provided in Table 1.4 of Chapter 1 of Vol. 2 (Energy) of the 2006 IPCC Guidelines. |                            |
| Description of measurement methods and procedures to be applied: | Not applicable, since the Project Proponent will use option d) (IPCC default values) in this case.  |                            |
| Frequency of monitoring/recording:                               | For option d): Any future revision of the IPCC Guidelines should be taken into account.   |                            |
| Value applied:   | <ul style="list-style-type: none"> <li>• Diesel: 0.0748 (tCO<sub>2</sub>/GJ).</li> <li>• Fuel oil: 0.0788 (tCO<sub>2</sub>/GJ).</li> </ul>  |                            |
| Monitoring equipment:  | Not applicable, since the Project Proponent will use option d) (IPCC default values) in this case.  |                            |
| QA/QC procedures to be applied:                                  | Not applicable, since the Project Proponent will use option d) (IPCC default values) in this case.  |                            |
| Calculation method:  | Not applicable in this case.  |                            |
| Any comment:   | Applicable where Option B is used.  |                            |

**Data and parameters monitored from the tool: “Project and leakage emissions from road transportation of freight” (Version 01.1)**

|                        |                  |
|------------------------|------------------|
| Data Unit / Parameter: | D <sub>f,m</sub> |
|------------------------|------------------|

|  |  |
|--|--|
| Data unit:   | Kilometre.   |
| Description:   | Return trip road distance between the origin and destination of freight transportation activity <i>f</i> in monitoring period <i>m</i> .                                   |
| Source of data:  | Records of vehicle operator and/or records by project participants.  |
| Description of measurement methods and procedures to be applied: | Determined once for each freight transportation activity <i>f</i> for a reference trip using the vehicle odometer or any other appropriate sources (e.g. on-line sources). |
| Frequency of monitoring/recording:                               | To be updated whenever the road distance changes.  |
| Value applied:   | 240 km (on average). This value was used for ex-ante emission reduction calculation.   |
| Monitoring equipment:  | Odometer or any other appropriate measurement system to determine road distance.   |
| QA/QC procedures to be applied:                                  | --   |
| Calculation method:  | N.A. Distances from biomass supply centres will be determined using odometers, on-line systems, etc.   |
| Any comment:   | Applicable to Option B.  |

|  |   |
|--|---|
| Data Unit / Parameter:   | <b>FR<sub>f,m</sub></b>   |
| Data unit:   | tonnes  |
| Description:   | Total mass of freight transported in freight transportation activity <i>f</i> in monitoring period <i>m</i> . |
| Source of data:  | Records by project participants.  |
| Description of measurement methods and procedures to be applied: | ---   |

|                                    |   |
|------------------------------------|---|
| Frequency of monitoring/recording: | Continuously.   |
| Value applied:                     | 327,104 (ton/yr) of wet biomass from third parties.   |
| Monitoring equipment:              | ---   |
| QA/QC procedures to be applied:    | ---   |
| Calculation method:                | N.A. Biomass residues from third parties will be measured (weighted) using dedicated weighbridges at the entrance of the biomass power plant. |
| Any comment:                       | Applicable to Option B.   |

**Data and parameters monitored from the tool: “Tool to calculate the emission factor for an electricity system (Version 03.0)”**

|  |   |
|--|---|
| Data Unit / Parameter:   | $FC_{i,m,i,y}$ , $FC_{i,k,y}$   |
| Data unit:   | Mass or volume unit.  |
| Description:   | Amount of fossil fuel type i consumed by power plant/unit m, k or n.  |
| Source of data:  | Utility or government record or official publications.  |
| Description of measurement methods and procedures to be applied: | ---   |
| Frequency of monitoring/recording:                               | <ul style="list-style-type: none"> <li>• Simple adjusted OM: Annually during the crediting period for the relevant year.</li> <li>• Build Margin BM: For the first crediting period, annually ex-post. For the second and third crediting period, only once ex-ante at the start of the second crediting period.</li> </ul> |
| Value applied:   | See Annex 2 of this document.   |
| Monitoring equipment:  | Not applicable.   |
| QA/QC procedures to be applied:                                  | ---   |
| Calculation method:  | Not applicable.   |
| Any comment:   | ---   |

| Data Unit / Parameter:   | NCV <sub>i,y</sub>   |             |                                      |  |   |  |  |  |    |
|--|--|-------------|--------------------------------------|--|---|--|--|--|----|
| Data unit:   | GJ/mass or volume unit.  |             |                                      |  |   |  |  |  |    |
| Description:   | Net calorific value (energy content) of fossil fuel type i in year y.  |             |                                      |  |   |  |  |  |    |
| Source of data:  | <p>The following data sources may be used in the relevant conditions apply:</p> <table border="1"> <thead> <tr> <th>Data source</th> <th>Conditions for using the data source</th> </tr> </thead> <tbody> <tr> <td>Values provided by the fuel supplier of the power plants invoices.</td> <td>If data is collected from power plant operators (e.g. utilities).</td> </tr> <tr> <td>Regional or national average default values.</td> <td>If values are reliable and documented in regional or national energy statistics/energy balances.</td> </tr> <tr> <td>IPCC default values at the lower limit of the uncertainty at a 95% confidence interval as provided in Table 1.2 of Chapter 1 of Vol. 2 (Energy) of the 2006 IPCC Guidelines on National GHG Inventories.</td> <td>--</td> </tr> </tbody> </table> <p>In this case, there exist reliable and documented national energy statistics therefore; the source used for the emission reduction calculation was the CNE (National Energy Commission) Energy Balance.</p> | Data source | Conditions for using the data source | Values provided by the fuel supplier of the power plants invoices. | If data is collected from power plant operators (e.g. utilities). | Regional or national average default values. | If values are reliable and documented in regional or national energy statistics/energy balances. | IPCC default values at the lower limit of the uncertainty at a 95% confidence interval as provided in Table 1.2 of Chapter 1 of Vol. 2 (Energy) of the 2006 IPCC Guidelines on National GHG Inventories. | -- |
| Data source  | Conditions for using the data source   |             |                                      |  |   |  |  |  |    |
| Values provided by the fuel supplier of the power plants invoices.   | If data is collected from power plant operators (e.g. utilities).  |             |                                      |  |   |  |  |  |    |
| Regional or national average default values.   | If values are reliable and documented in regional or national energy statistics/energy balances.   |             |                                      |  |   |  |  |  |    |
| IPCC default values at the lower limit of the uncertainty at a 95% confidence interval as provided in Table 1.2 of Chapter 1 of Vol. 2 (Energy) of the 2006 IPCC Guidelines on National GHG Inventories. | --   |             |                                      |  |   |  |  |  |    |
| Description of measurement methods and procedures to be applied:   | ---  |             |                                      |  |   |  |  |  |    |
| Frequency of monitoring/recording:   | <ul style="list-style-type: none"> <li>Simple adjusted OM: Annually during the crediting period for the relevant year.</li> <li>Build Margin, BM: For the first crediting period, annually ex-post. For the second and third crediting period, only once ex-ante at the start of the second crediting period.</li> </ul>   |             |                                      |  |   |  |  |  |    |
| Value applied:   | See the Annex 2 of this document.  |             |                                      |  |   |  |  |  |    |
| Monitoring equipment:  | Not applicable.  |             |                                      |  |   |  |  |  |    |

|                                 |  |
|---------------------------------|--|
| QA/QC procedures to be applied: | ---  |
| Calculation method:             | Not applicable.  |
| Any comment:                    | The gross calorific value (GCV) of the fuel can be used, if gross calorific values are provided by the data sources used. Make sure that in such cases also a gross calorific value basis is used for CO <sub>2</sub> emission factor. |

| Data Unit / Parameter:   | EF <sub>CO2,i,y</sub> , EF <sub>CO2,m,i,y</sub>  |             |                                      |  |   |  |  |  |    |
|--|--|-------------|--------------------------------------|--|---|--|--|--|----|
| Data unit:   | (tCO <sub>2</sub> /GJ)   |             |                                      |  |   |  |  |  |    |
| Description:   | CO <sub>2</sub> emission factor of fossil fuel type i used in power unit m in year y.  |             |                                      |  |   |  |  |  |    |
| Source of data:  | <p>The following data sources may be used in the relevant conditions apply:</p> <table border="1"> <thead> <tr> <th>Data source</th> <th>Conditions for using the data source</th> </tr> </thead> <tbody> <tr> <td>Values provided by the fuel supplier of the power plants invoices.</td> <td>If data is collected from power plant operators (e.g. utilities).</td> </tr> <tr> <td>Regional or national average default values.</td> <td>If values are reliable and documented in regional or national energy statistics/energy balances.</td> </tr> <tr> <td>IPCC default values at the lower limit of the uncertainty at a 95% confidence interval as provided in Table 1.4 of Chapter 1 of Vol. 2 (Energy) of the 2006 IPCC Guidelines on National GHG Inventories.</td> <td>--</td> </tr> </tbody> </table> <p>Since no actual, national or regional values are available, the Project Proponent will use the IPCC default factors for the emission reduction calculation.</p> | Data source | Conditions for using the data source | Values provided by the fuel supplier of the power plants invoices. | If data is collected from power plant operators (e.g. utilities). | Regional or national average default values. | If values are reliable and documented in regional or national energy statistics/energy balances. | IPCC default values at the lower limit of the uncertainty at a 95% confidence interval as provided in Table 1.4 of Chapter 1 of Vol. 2 (Energy) of the 2006 IPCC Guidelines on National GHG Inventories. | -- |
| Data source  | Conditions for using the data source   |             |                                      |  |   |  |  |  |    |
| Values provided by the fuel supplier of the power plants invoices.   | If data is collected from power plant operators (e.g. utilities).  |             |                                      |  |   |  |  |  |    |
| Regional or national average default values.   | If values are reliable and documented in regional or national energy statistics/energy balances.   |             |                                      |  |   |  |  |  |    |
| IPCC default values at the lower limit of the uncertainty at a 95% confidence interval as provided in Table 1.4 of Chapter 1 of Vol. 2 (Energy) of the 2006 IPCC Guidelines on National GHG Inventories. | --   |             |                                      |  |   |  |  |  |    |
| Description of measurement methods and procedures to be applied:   | ---  |             |                                      |  |   |  |  |  |    |
| Frequency of monitoring/recording:   | <ul style="list-style-type: none"> <li>Simple adjusted OM: Annually during the</li> </ul>  |             |                                      |  |   |  |  |  |    |

|                                 |  |
|---------------------------------|--|
|                                 | <p>crediting period for the relevant year.</p> <ul style="list-style-type: none"> <li>Build Margin BM: For the first crediting period, annually ex-post. For the second and third crediting period, only once ex-ante at the start of the second crediting period.</li> </ul>  |
| Value applied:                  | <p>Diesel: 0.0726 (tCO<sub>2</sub>/GJ)<br/>         IFO 180: 0.0755 (tCO<sub>2</sub>/GJ)<br/>         Natural Gas: 0.0543 (tCO<sub>2</sub>/GJ)<br/>         Coal: 0.0895 (tCO<sub>2</sub>/GJ)<br/>         Petcoke: 0.0829 (tCO<sub>2</sub>/GJ)<br/>         Liquid petroleum gases: 0.0616 (tCO<sub>2</sub>/GJ)</p> |
| Monitoring equipment:           | Not applicable.  |
| QA/QC procedures to be applied: | ---  |
| Calculation method:             | Not applicable.  |
| Any comment:                    | ---  |

|  |   |
|--|---|
| Data Unit / Parameter:   | <b>EG<sub>m,y</sub>, EG<sub>k,y</sub></b>   |
| Data unit:   | (MWh)   |
| Description:   | Net electricity generated by power plant/unit m, k in year y.   |
| Source of data:  | Utility or government records or official publications.   |
| Description of measurement methods and procedures to be applied: | ---   |
| Frequency of monitoring/recording:                               | <ul style="list-style-type: none"> <li>Simple adjusted OM: Annually during the crediting period for the relevant year.</li> <li>Build Margin BM: For the first crediting period, annually ex-post. For the second and third crediting period, only once ex-ante at the start of the second crediting period.</li> </ul> |
| Value applied:   | See Annex 2 of this document.   |
| Monitoring equipment:  | Not applicable.   |
| QA/QC procedures to be applied:                                  | ---   |
| Calculation method:  | Not applicable.   |
| Any comment:   | ---   |

### 4.3 Description of the Monitoring Plan

The Project Proponent will implement monitoring procedures according to the monitoring methodology chosen for this project activity. This monitoring methodology will account for emission reductions and leakage effects in an accurate and conservative manner. According to the monitoring methodology of the ACM0006 (Version 12.1.1), all data collected as part of monitoring will be archived electronically and kept at least for 2 years after the end of the last crediting period.

The monitoring methodology will be supported by a dedicated management information system designed exclusively to guarantee the quality of the information related to the Viñales biomass power plant project activity. The system will use the same principles of the ISO 9001 version 2000 standard and will be incorporated to the plant's management information system. To ensure the quality and integrity of the management system, Arauco Bioenergía S.A. personnel will perform periodic internal audits.

**Monitoring information flow of Viñales biomass power plant project activity**

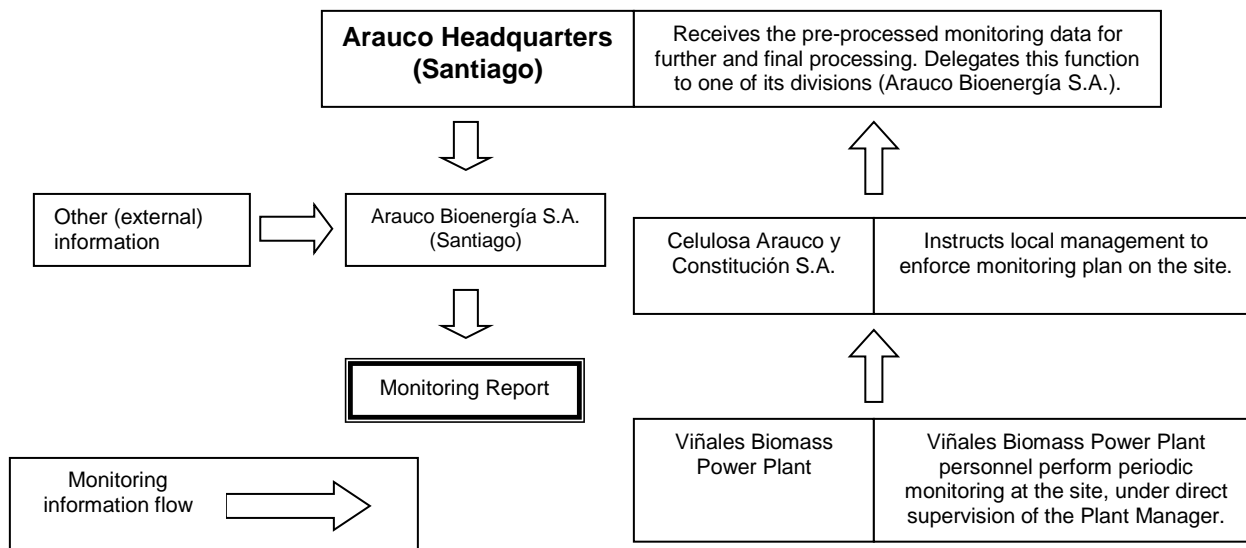

Arauco counts with on-site personnel (at the project activity site), who will be in charge of gathering and registering all the required information described in the monitoring plan. Such duties will be incorporated to the personnel’s everyday activities to ensure continuity and high-quality standards. The information will be partially processed and stored there, and will be sent periodically (monthly) to Arauco Bioenergía in Santiago for further and final processing (table formats, reports, etc.). With the information at this level, Arauco will be in condition to certify the emission reduction of the Viñales project activity periodically (i.e. once every year).

Finally, since the Viñales sawmill is a modern facility and counts with very high quality, security and environmental standards, there are plenty of safety measures and security procedures implemented in the facility in case of emergencies or accidental events that might lead to unintended emissions. Particularly, for events related to accidental fires, the mill counts with on-line fire sensors that continuously monitor the entire production cycle and has a fire brigade especially trained to fight any fire contingency in the site.

**5 ENVIRONMENTAL IMPACT**

The impacts of the project that were identified in the Environmental Impact Declaration (DIA) are the following:

- **Solid and Liquid Wastes:** The operation of the plant will generate sewage water that will be treated in a sewage treatment plant in accordance with the Chilean regulations. The project will consume all the biomass residues that will be generated by the Viñales sawmill. Very low amounts of residues, like ashes, plastics and other industrial waste will be sent to a landfill, also according with the Chilean regulations.
- **Atmospheric emissions:** The emissions are related to noise and particulate material. Both of them are treated with state of art technology that put them below the emission limit factor required by the Chilean regulations.

All the impacts addressed above, were mentioned and resolved during the corresponding DIA procedure.

No transboundary impacts are considered for this project.

## 6 STAKEHOLDER COMMENTS

The Project Proponent used the following media to present the proposed project activity to the local community:

- Television: Interviews in TV programs.
- Radio: Interviews.
- Press: Articles describing the proposed project, leaflets with information about Climate Change and the proposed project activity.
- Door-to-door presentation of the project to the local community.
- Meetings with local stake holders (see below).

The Project Proponent organized several meetings with the local community, the local authorities and other stakeholders in the VII Region. In these meeting, the project proponent described the technical aspects related to the project and the way in which the proposed project would contribute to reduce greenhouse gas emissions. Comments and impressions of the stakeholders were recorded and gathered via a Q&A session at the end of the meetings and via a brief questionnaire that was handed out by Arauco personnel and filled in by the attendants before they left the meeting. The meetings took place during July, 2008 and the following stakeholders were involved:

- Environmental authorities of the VII Region.
- Viñales personnel.
- Local business community.
- CORMA (the Wood Corporation).
- Fisherman federation of the VII Region.
- Environmental Committee of Constitución.
- Personnel of the Constitución pulp mill.
- Other professionals and members of the workforce of the VII Region.

## **ANNEX 1**

## **Biomass residues transported via pneumatic transportation system to the power plant**

The types of meters currently available in the market make it very difficult and complex to accurately measure the biomass residues that are transported via a pneumatic transportation system. For this reason, the Project Proponent will present a simple calculation algorithms use in Viñales sawmill and Remanufacture plant to calculate these residues both in an accurate and conservative way. It is important to note that Project Proponent will receive a monthly volume of residues and is not involved in the calculation algorithms.

### **1. Biomass residues generated in the Viñales remanufacture plant**

The remanufacture plant performs different types of tasks:

1. Brushing: The four faces of the wood piece are brushed in order to maintain the stability and superficial quality of the wood.
2. Logging: The logs are cut perpendicularly in order to separate the knots, generating wood blocks free from defects.
3. Finger: Joint of wood-blocks through dented surfaces which allows producing wood blanks of determined lengths.
4. Band sawing: Wood blank longitudinal cut aimed at obtaining the best section for the molding machine.
5. Molding: Process in which the wood blocks are shaped into different pre-defined forms and designs.
6. Painting and coating: Finishing process through which the different wood-products coming from the molding process are painted and coated with a special paste.
7. Sliding table saw: Pre-finished wood products are further trimmed in order to comply with the exact measures of the final product.

All the processes above generate biomass residues. In every one of them, the biomass residue calculation is based on the difference between the wood that enters and exits the process (in some cases, this is captured by a performance factor). The volume measurement is carried out using normal length meter, which is a standard practice in this industry. No calibration for this type of meter is needed in this case. The wood density,  $D_r$ , is assumed a constant parameter (of 459 (kg/m<sup>3</sup>)) for all the different moldings products. This is deemed a reasonable assumption in this case, since all the molding products come from dried (and stabilized) wood from Radiata Pine. The measurement is carried out on a continuous basis, for all the production batches of the products mentioned above.

The equations below present the ways in which each type of biomass residue will be calculated. Each equation calculates the mass (kg) of the corresponding biomass residue:

**1. Biomass residues generated from the Brushing process:**

$$\text{Biomass residues} = a * b * Dr$$

Where:

a = Green wood volume consumption of the brushing machine (m<sup>3</sup>).

b = Real (unadjusted) performance factor of the brushing machine (number).

Dr = Wood density (kg/m<sup>3</sup>).

**2. Biomass residues generated from the Logging process:**

$$\text{Biomass residues} = c * d * Dr$$

Where:

c = Logs volume consumption (m<sup>3</sup>).

b = Performance factor for the production of wood-splinters. This parameter is determined based on empirical measurements (number).

Dr = Wood density (kg/m<sup>3</sup>).

**3. Biomass residues generated from the production of finger-joints:**

$$\text{Biomass residues} = m * q * Dr$$

Where:

m = Sawdust volume generated from processing one wood-blank in the finger-joint process (m<sup>3</sup>).

q = Amount of wood-blocks produced in the finger-joint process (number).

Dr = Wood density (kg/m<sup>3</sup>).

**4. Biomass residues generated from the band-sawing process:**

$$\text{Biomass residues} = e * f * g * Dr$$

Where:

e = Wood thickness that is being sawed (m).

f = Linear meters of cuts along the thickness of the wood-blanks (m).

g = Cut width (0.0022 m).

Dr = Wood density (kg/m<sup>3</sup>).

**5. Biomass residues generated from the molding process:**

$$\text{Biomass} = \text{shavings} + \text{splinters}$$

$$\text{Shavings} = (h-i) * (1-J) * Dr$$

Where:

h = Wood-blank volume consumed by the molding machine (m<sup>3</sup>).

i = Sawdust volume generated from cutting the wood-blanks to the specified thickness (m<sup>3</sup>).

j = Performance index from consuming wood-blanks and producing wood-moldings. This factor is calculated from the geometry of the wood molding (number for each type of molding).

Dr = Wood density (kg/m<sup>3</sup>).

$$\text{Splinters} = k * I * Dr$$

Where:

k = Molding volume production (m<sup>3</sup>).

I = Process performance (number).

Dr = Wood density (kg/m<sup>3</sup>).

**6. Biomass residues generated from the painting, coating and squaring processes:**

$$\text{Biomass residues} = r * s * Dr$$

Where:

r = Input volume moldings to the process (m<sup>3</sup>).

s = Process performance (number. Empirical, determined for the process).

Dr = Wood density (kg/m<sup>3</sup>).

## 2. Biomass residues generated in the Viñales sawmill plant

The Viñales sawmill generates the following sub-types of biomass residues:

- Shavings: Which are transported via the pneumatic transportation system to the Viñales power plant.
- Bark: Which is transported to the Viñales power plant via trucks.

Considering that the biomass residues that are transported via trucks are weighed at the entrance of the Viñales power plant, the calculation of the biomass residues is only needed for the other sub-type of biomass: the biomass residues generating in the Shaving process.

$$\text{Biomass residues} = I \cdot (1 - P) \cdot D_s$$

and

$$P = [S_o / (S_i \cdot f_c)]$$

Where:

I = Wood volume consumed by the Shaving process (m<sup>3</sup>).

P = Shaving performance index (number).

D<sub>s</sub> = Average wood density (kg/m<sup>3</sup>).

S<sub>o</sub> = Wood section that exists the shaving process (m<sup>2</sup>).

S<sub>i</sub> = Wood section that enters the shaving process (m<sup>2</sup>).

f<sub>c</sub> = Wood correction factor due to wood drying as a result of the shaving process (number).

Note the following:

- In this case, the wood density (D<sub>s</sub>) will be measured twice per year (i.e. one measurement each semester), taking at least 5 wood samples each time. The instruments involved in this measurement (weight meter) will be the same that the ones involved in the determination of the biomass humidity in the Viñales power plant, therefore they will undergo maintenance and calibration in accordance with the ACM0006 requirements. As QC/QA procedures, the person in charge of measuring this parameter will compare it with previous measurements and/or with literature values. In case of significant differences/discrepancies that cannot be reasonably explained, the person in charge will carry out new measurements.
- The contraction factor (f<sub>c</sub>) is determined using empirical data associated to the shaving process and it is assumed to remain constant (0.965). This is deemed a reasonable assumption, since the conditions under which the shaving process is carried out do not change over time.

## ANNEX 2

**NET POWER GENERATION IN 2011**

Source: CDEC-SIC Daily reports and plant energy consumption report

| POWER PLANT              | POWER OUTPUT (MW) | PLANT TYPE       | FUEL TYPE   | LOW COST / MUST RUN | NET ENERGY GEN (GWh/yr) | UNIT                        | FOSSIL FUEL CONSUMPTION (Unit) |
|--------------------------|-------------------|------------------|-------------|---------------------|-------------------------|-----------------------------|--------------------------------|
| 1 Los Molles             | 18                | Run of the river | Hydro       | Yes                 | 27.2                    | N.C.                        | 0.00                           |
| 2 Sauce Andes            | 1.1               | Run of the river | Hydro       | Yes                 | 5.0                     | N.C.                        | 0.00                           |
| 3 Aconagua               | 74                | Run of the river | Hydro       | Yes                 | 291.6                   | N.C.                        | 0.00                           |
| 4 Los Quiños             | 39.3              | Run of the river | Hydro       | Yes                 | 199.1                   | N.C.                        | 0.00                           |
| 5 Florida                | 28.5              | Run of the river | Hydro       | Yes                 | 75.0                    | N.C.                        | 0.00                           |
| 6 Maitenes               | 31                | Run of the river | Hydro       | Yes                 | 115.3                   | N.C.                        | 0.00                           |
| 7 Alfalfal               | 178               | Run of the river | Hydro       | Yes                 | 670.1                   | N.C.                        | 0.00                           |
| 8 Quelltehuas            | 49                | Run of the river | Hydro       | Yes                 | 308.9                   | N.C.                        | 0.00                           |
| 9 Puntilla               | 22                | Run of the river | Hydro       | Yes                 | 121.3                   | N.C.                        | 0.00                           |
| 10 Volcan                | 13                | Run of the river | Hydro       | Yes                 | 87.6                    | N.C.                        | 0.00                           |
| 11 Los Morros            | 3.1               | Run of the river | Hydro       | Yes                 | 10.1                    | N.C.                        | 0.00                           |
| 12 Sauzal 50Hz           | 76.8              | Run of the river | Hydro       | Yes                 | 385.9                   | N.C.                        | 0.00                           |
| 13 Sauzal 60Hz           | 76.8              | Run of the river | Hydro       | Yes                 | 0.3                     | N.C.                        | 0.00                           |
| 14 Sauzalito             | 12                | Run of the river | Hydro       | Yes                 | 67.4                    | N.C.                        | 0.00                           |
| 15 Cunillique            | 89                | Run of the river | Hydro       | Yes                 | 483.1                   | N.C.                        | 0.00                           |
| 16 San Ignacio           | 37                | Run of the river | Hydro       | Yes                 | 171.0                   | N.C.                        | 0.00                           |
| 17 Loma Alta             | 40                | Run of the river | Hydro       | Yes                 | 227.2                   | N.C.                        | 0.00                           |
| 18 Rucue                 | 178.4             | Run of the river | Hydro       | Yes                 | 916.4                   | N.C.                        | 0.00                           |
| 19 Pullinque             | 51.4              | Run of the river | Hydro       | Yes                 | 197.5                   | N.C.                        | 0.00                           |
| 20 Pilmaiquén            | 39                | Run of the river | Hydro       | Yes                 | 238.5                   | N.C.                        | 0.00                           |
| 21 Capullo               | 11                | Run of the river | Hydro       | Yes                 | 69.2                    | N.C.                        | 0.00                           |
| 22 Peuchén               | 80                | Run of the river | Hydro       | Yes                 | 220.9                   | N.C.                        | 0.00                           |
| 23 Mampil                | 49                | Run of the river | Hydro       | Yes                 | 157.6                   | N.C.                        | 0.00                           |
| 24 Chacabuco             | 25.5              | Run of the river | Hydro       | Yes                 | 122.4                   | N.C.                        | 0.00                           |
| 25 Antuco                | 320               | Run of the river | Hydro       | Yes                 | 1,466.5                 | N.C.                        | 0.00                           |
| 26 Abanico               | 136               | Run of the river | Hydro       | Yes                 | 282.1                   | N.C.                        | 0.00                           |
| 27 Isla                  | 68                | Run of the river | Hydro       | Yes                 | 387.1                   | N.C.                        | 0.00                           |
| 28 Machicura             | 95                | Run of the river | Hydro       | Yes                 | 409.6                   | N.C.                        | 0.00                           |
| 29 Eyzaguirre            | 2.1               | Run of the river | Hydro       | Yes                 | 3.7                     | N.C.                        | 0.00                           |
| 30 Quileco               | 30                | Run of the river | Hydro       | Yes                 | 376.1                   | N.C.                        | 0.00                           |
| 31 El Rincón             | 0.28              | Run of the river | Hydro       | Yes                 | 2.4                     | N.C.                        | 0.00                           |
| 32 Chiburgo              | 19.4              | Run of the river | Hydro       | Yes                 | 66.8                    | N.C.                        | 0.00                           |
| 33 Palmucho              | 32                | Run of the river | Hydro       | Yes                 | 223.7                   | N.C.                        | 0.00                           |
| 34 Hornitos              | 55                | Run of the river | Hydro       | Yes                 | 173.0                   | N.C.                        | 0.00                           |
| 35 Puciaro               | 6                 | Run of the river | Hydro       | Yes                 | 13.9                    | N.C.                        | 0.00                           |
| 36 Ojos de Agua          | 9                 | Run of the river | Hydro       | Yes                 | 41.3                    | N.C.                        | 0.00                           |
| 37 Coya                  | 10.8              | Run of the river | Hydro       | Yes                 | 69.1                    | N.C.                        | 0.00                           |
| 38 Lircay                | 19                | Run of the river | Hydro       | Yes                 | 119.6                   | N.C.                        | 0.00                           |
| 39 El Manzano            | 4.85              | Run of the river | Hydro       | Yes                 | 25.1                    | N.C.                        | 0.00                           |
| 40 Pehui                 | 1.1               | Run of the river | Hydro       | Yes                 | 6.6                     | N.C.                        | 0.00                           |
| 41 Truful Truful         | 0.5               | Run of the river | Hydro       | Yes                 | 1.7                     | N.C.                        | 0.00                           |
| 42 La Paloma             | 5.4               | Run of the river | Hydro       | Yes                 | 4.2                     | N.C.                        | 0.00                           |
| 43 Trueno                | 5.6               | Run of the river | Hydro       | Yes                 | 25.9                    | N.C.                        | 0.00                           |
| 44 San Clemente          | 5.5               | Run of the river | Hydro       | Yes                 | 17.2                    | N.C.                        | 0.00                           |
| 45 Carbomet              | 5.12              | Run of the river | Hydro       | Yes                 | 40.4                    | N.C.                        | 0.00                           |
| 46 La Higuera            | 154.7             | Run of the river | Hydro       | Yes                 | 198.0                   | N.C.                        | 0.00                           |
| 47 Juncalito             | 1.5               | Run of the river | Hydro       | Yes                 | 2.6                     | N.C.                        | 0.00                           |
| 48 El Tártaro            | 0.14              | Run of the river | Hydro       | Yes                 | 0.5                     | N.C.                        | 0.00                           |
| 49 Guayacán              | 12                | Run of the river | Hydro       | Yes                 | 72.0                    | N.C.                        | 0.00                           |
| 50 Confluencia           | 155               | Run of the river | Hydro       | Yes                 | 130.1                   | N.C.                        | 0.00                           |
| 51 Maniposas             | 6                 | Run of the river | Hydro       | Yes                 | 29.6                    | N.C.                        | 0.00                           |
| 52 Los Corrales          | 0.8               | Run of the river | Hydro       | Yes                 | 2.8                     | N.C.                        | 0.00                           |
| 53 Carena                | 10                | Run of the river | Hydro       | Yes                 | 49.4                    | N.C.                        | 0.00                           |
| 54 Diuto                 | NO DATA           | Run of the river | Hydro       | Yes                 | 4.8                     | N.C.                        | 0.00                           |
| 55 Dongo                 | NO DATA           | Run of the river | Hydro       | Yes                 | 12.9                    | N.C.                        | 0.00                           |
| 56 Mallarauco            | 3.4               | Run of the river | Hydro       | Yes                 | 12.1                    | N.C.                        | 0.00                           |
| 57 Licán                 | NO DATA           | Run of the river | Hydro       | Yes                 | 41.7                    | N.C.                        | 0.00                           |
| 58 Chacayes              | NO DATA           | Run of the river | Hydro       | Yes                 | 93.1                    | N.C.                        | 0.00                           |
| 59 Muchi                 | NO DATA           | Run of the river | Hydro       | Yes                 | 0.5                     | N.C.                        | 0.00                           |
| 60 La Arena              | NO DATA           | Run of the river | Hydro       | Yes                 | 1.6                     | N.C.                        | 0.00                           |
| 61 Taltal 2 GNL          | 122.45            | Open Cycle       | LNG         | No                  | 15.7                    | (MM m <sup>3</sup> -std/yr) | 5.00                           |
| 62 Taltal 1 GNL          | 122.45            | Open Cycle       | LNG         | No                  | 66.4                    | (MM m <sup>3</sup> -std/yr) | 22.03                          |
| 63 Taltal                | 244.9             | Open Cycle       | Diesel      | No                  | 66.8                    | (000 ton/yr)                | 19.43                          |
| 64 D. Almagro            | 23.8              | Open Cycle       | Diesel      | No                  | 0.6                     | (000 ton/yr)                | 0.29                           |
| 65 El Salvador           | 23.8              | Open Cycle       | Diesel      | No                  | 0.2                     | (000 ton/yr)                | 0.09                           |
| 66 Guacolda 1            | 152               | Coal/Steam       | Coal        | No                  | 1,104.1                 | (000 ton/yr)                | 567.12                         |
| 67 Guacolda 2            | 152               | Coal/Steam       | Coal        | No                  | 943.9                   | (000 ton/yr)                | 462.46                         |
| 68 Guacolda 3            | 152               | Coal/Steam       | Coal        | No                  | 1,162.7                 | (000 ton/yr)                | 520.21                         |
| 69 Guacolda 4            | 152               | Coal/Steam       | Coal        | No                  | 1,123.8                 | (000 ton/yr)                | 536.04                         |
| 70 Huasco TV             | 16                | Coal/Steam       | Coal        | No                  | 0.0                     | (000 ton/yr)                | 0.00                           |
| 71 Huasco TG             | 64.23             | Open Cycle       | Diesel      | No                  | 0.8                     | (000 ton/yr)                | 0.47                           |
| 72 Huasco TG IFO         | 64.23             | Open Cycle       | IFO 180     | No                  | 0.2                     | (000 ton/yr)                | 0.08                           |
| 73 L Verde TG            | 18.8              | Open Cycle       | Diesel      | No                  | 1.5                     | (000 ton/yr)                | 0.63                           |
| 74 Los Vientos TG        | 132               | Open Cycle       | Diesel      | No                  | 42.6                    | (000 ton/yr)                | 12.56                          |
| 75 Nehuenco              | 368.4             | Combined Cycle   | Natural Gas | No                  | 0.0                     | (MM m <sup>3</sup> -std/yr) | 0.00                           |
| 76 Nehuenco Diesel       | 368.4             | Combined Cycle   | Diesel      | No                  | 782.3                   | (000 ton/yr)                | 130.95                         |
| 77 Nehuenco GNL          | 368.4             | Combined Cycle   | LNG         | No                  | 724.9                   | (MM m <sup>3</sup> -std/yr) | 134.74                         |
| 78 Nehuenco TG 9B        | 108               | Open Cycle       | Natural Gas | No                  | 4.5                     | (MM m <sup>3</sup> -std/yr) | 1.41                           |
| 79 Nehuenco TG 9B Diesel | 108               | Open Cycle       | Diesel      | No                  | 0.0                     | (000 ton/yr)                | 0.00                           |
| 80 Nehuenco TG 9B GNL    | 108               | Open Cycle       | LNG         | No                  | 15.4                    | (MM m <sup>3</sup> -std/yr) | 2.84                           |
| 81 Nehuenco II           | 398.3             | Combined Cycle   | Natural Gas | No                  | 0.0                     | (MM m <sup>3</sup> -std/yr) | 0.00                           |
| 82 Nehuenco II Diesel    | 398.3             | Combined Cycle   | Diesel      | No                  | 497.5                   | (000 ton/yr)                | 83.47                          |
| 83 Nehuenco II GNL       | 398.3             | Combined Cycle   | LNG         | No                  | 1,301.1                 | (MM m <sup>3</sup> -std/yr) | 242.03                         |
| 84 San Isidro            | 379               | Combined Cycle   | Natural Gas | No                  | 3.6                     | (MM m <sup>3</sup> -std/yr) | 0.73                           |
| 85 San Isidro Diesel     | 379               | Combined Cycle   | Diesel      | No                  | 10.9                    | (000 ton/yr)                | 2.01                           |
| 86 San Isidro GNL        | 379               | Combined Cycle   | LNG         | No                  | 2,425.0                 | (MM m <sup>3</sup> -std/yr) | 483.46                         |
| 87 San Isidro II         | 353               | Combined Cycle   | Natural Gas | No                  | 0.0                     | (MM m <sup>3</sup> -std/yr) | 0.00                           |
| 88 San Isidro II Diesel  | 353               | Combined Cycle   | Diesel      | No                  | 8.0                     | (000 ton/yr)                | 1.47                           |
| 89 San Isidro II GNL     | 353               | Combined Cycle   | LNG         | No                  | 3,027.1                 | (MM m <sup>3</sup> -std/yr) | 564.48                         |
| 90 Ventanas 1            | 320               | Coal/Steam       | Coal        | No                  | 857.5                   | (000 ton/yr)                | 347.63                         |
| 91 Ventanas 2            | 220               | Coal/Steam       | Coal        | No                  | 1,357.6                 | (000 ton/yr)                | 550.96                         |
| 92 Nueva Ventanas        | 272               | Coal/Steam       | Coal        | No                  | 1,856.2                 | (000 ton/yr)                | 733.88                         |
| 93 L Verde               | 54.7              | Coal/Steam       | Coal        | No                  | 0.4                     | (000 ton/yr)                | 0.17                           |
| 94 Nueva Renca GNL       | 379               | Gas              | LNG         | No                  | 1,719.6                 | (MM m <sup>3</sup> -std/yr) | 348.71                         |
| 95 Nueva Renca FA        | 353               | Steam            | LPG         | No                  | 1.3                     | (000 ton/yr)                | 0.14                           |
| 96 Nueva Renca Diesel    | 379               | Combined Cycle   | Diesel      | No                  | 275.1                   | (000 ton/yr)                | 57.83                          |
| 97 Renca                 | 100               | Diesel/Steam     | Diesel      | No                  | 25.7                    | (000 ton/yr)                | 9.36                           |
| 98 Constitución          | 11.1              | Biomass/steam    | Biomass     | Yes                 | 48.8                    | N.C.                        | 0.00                           |
| 99 Constitución A.       | 8                 | Biomass/steam    | Biomass     | Yes                 | 37.5                    | N.C.                        | 0.00                           |
| 100 Petropover           | 75                | Petcoke/steam    | Petcoke     | Yes                 | 292.5                   | (000 ton/yr)                | 140.24                         |

**FOSSIL FUEL CO<sub>2</sub> EMISSION DATA**

(SOURCES: CNE ENERGY BALANCE 2010 AND REVISED 2006 IPCC GUIDELINES FOR NATIONAL GREENHOUSE GAS INVENTORIES)

**FUEL DATA**

**COAL**

|                                 |                              |       |  |
|---------------------------------|------------------------------|-------|--|
| Net calorific value             | (TJ / 000 ton)               | 27.8  | IPCC default value, Volume 2, Table 1.4. |
| Emission factor                 | (tCO <sub>2</sub> / TJ)      | 89.5  |  |
| CO <sub>2</sub> Emission factor | (tCO <sub>2</sub> / 000 ton) | 2,490 |  |

**PETCOKE**

|                                 |                              |       |  |
|---------------------------------|------------------------------|-------|--|
| Net calorific value             | (TJ / 000 ton)               | 27.8  | IPCC default value, Volume 2, Table 1.4. |
| Emission factor                 | (tCO <sub>2</sub> / TJ)      | 82.9  |  |
| CO <sub>2</sub> Emission factor | (tCO <sub>2</sub> / 000 ton) | 2,307 |  |

**DIESEL**

|                                 |                              |       |  |
|---------------------------------|------------------------------|-------|--|
| Net calorific value             | (TJ / 000 ton)               | 43.3  | IPCC default value, Volume 2, Table 1.4. |
| Emission factor                 | (tCO <sub>2</sub> / TJ)      | 72.6  |  |
| CO <sub>2</sub> Emission factor | (tCO <sub>2</sub> / 000 ton) | 3,145 |  |

**NATURAL GAS**

|                                 |   |       |  |
|---------------------------------|---|-------|--|
| Net calorific value             | (TJ / MM m <sup>3</sup> )               | 35.2  | IPCC default value, Volume 2, Table 1.4. |
| Emission factor                 | (tCO <sub>2</sub> / TJ)                 | 54.3  |  |
| CO <sub>2</sub> Emission factor | (tCO <sub>2</sub> / MM m <sup>3</sup> ) | 1,910 |  |

**IFO 180 (RESIDUAL FUEL OIL)**

|                                 |                              |       |  |
|---------------------------------|------------------------------|-------|--|
| Net calorific value             | (TJ / 000 ton)               | 41.8  | IPCC default value, Volume 2, Table 1.4. |
| Emission factor                 | (tCO <sub>2</sub> / TJ)      | 75.5  |  |
| CO <sub>2</sub> Emission factor | (tCO <sub>2</sub> / 000 ton) | 3,153 |  |

**BUTANE GAS (NATURAL GAS LIQUIDS)**

|                                 |                              |       |  |
|---------------------------------|------------------------------|-------|--|
| Net calorific value             | (TJ / 000 ton)               | 45.6  | IPCC default value, Volume 2, Table 1.4. |
| Emission factor                 | (tCO <sub>2</sub> / TJ)      | 61.6  |  |
| CO <sub>2</sub> Emission factor | (tCO <sub>2</sub> / 000 ton) | 2,807 |  |

**PROPANE GAS (NATURAL GAS LIQUIDS)**

|                                 |                              |       |  |
|---------------------------------|------------------------------|-------|--|
| Net calorific value             | (TJ / 000 ton)               | 45.6  | IPCC default value, Volume 2, Table 1.4. |
| Emission factor                 | (tCO <sub>2</sub> / TJ)      | 61.6  |  |
| CO <sub>2</sub> Emission factor | (tCO <sub>2</sub> / 000 ton) | 2,807 |  |

**OPERATING MARGIN CALCULATION**

ACCORDING TO ACM0002 v 13.0.0, METHODOLOGICAL TOOL v 3.0.0

Each year in which the project generation occurs.

|   |                              | 2011          |
|---|------------------------------|---------------|
| Total emissions from non-low cost / must run power plants | (tCO <sub>2</sub> /yr)       | 16,602,734    |
| Total emissions from low-cost / must-run power plants     | (tCO <sub>2</sub> /yr)       | 323,477       |
| Total energy generated in the SIC                         | (GWh/yr)                     | 45,041        |
| Total energy by non-low cost / must run power plants      | (GWh/yr)                     | 23,001        |
| Total energy by low cost / must run power plants          | (GWh/yr)                     | 22,039        |
| Factor λ  | (number)                     | 0.0001141553  |
| <b>Operating Margin</b>                                   | <b>(tCO<sub>2</sub>/GWh)</b> | <b>721.74</b> |

**Notes:**

- Low cost / must run units present very low GHG emissions, since they are basically hydro plants and very few biomass plants.

**BUILD MARGIN CALCULATION**

ACCORDING TO ACM0002 v 13.0.0, METHODOLOGICAL TOOL v 3.0.0

| Power plants                 | POWER OUTPUT (MW) | PLANT TYPE              | FUEL TYPE      | START OPERATION | CDM PROYECT | TOTAL GEN IN 2011 (GWh) | SIC EMISSION 2011 (tCO2/GWh) |
|------------------------------|-------------------|-------------------------|----------------|-----------------|-------------|-------------------------|------------------------------|
| La Arena                     | NO DATA           | Run of the river        | Hydro          | Nov-11          | No          | 2                       | 0                            |
| Muchi                        | NO DATA           | Run of the river        | Hydro          | Sep-11          | No          | 0                       | 0                            |
| <b>Loma Los Colorados II</b> | <b>9.8</b>        | <b>Biogas/engine</b>    | <b>Biogas</b>  | <b>Sep-11</b>   | <b>Yes</b>  | <b>0</b>                | <b>0</b>                     |
| Santa María                  | 370               | Coal/Steam              | Coal           | Sep-11          | No          | 96                      | 903                          |
| JCE                          | 0.8               | Diesel engine           | Diesel         | Sep-11          | No          | 0                       | 0                            |
| Punta Colorada eólico        | 20                | Aeolics                 | Wind           | Sep-11          | No          | 4                       | 0                            |
| Danisco                      | 0.8               | Diesel engine           | Diesel         | Sep-11          | No          | 0                       | 0                            |
| Chacayes                     | NO DATA           | Run of the river        | Hydro          | Aug-11          | No          | 93                      | 0                            |
| Lautaro-Comasa               | 25                | Biomass/steam           | Biomass        | Aug-11          | No          | 53                      | 0                            |
| Lonquimay                    | 1.6               | Diesel engine           | Diesel         | Aug-11          | No          | 0                       | 840                          |
| Tirúa                        | 0.8               | Diesel engine           | Diesel         | Aug-11          | No          | 0                       | 840                          |
| Skretting Osorno             | 3                 | Diesel engine           | Diesel         | Jun-11          | No          | 0                       | 0                            |
| Energía Pacifico             | 15.6              | Biomass/steam           | Biomass        | Jun-11          | No          | 34                      | 0                            |
| Licán                        | NO DATA           | Run of the river        | Hydro          | Jun-11          | No          | 42                      | 0                            |
| Dongo                        | NO DATA           | Run of the river        | Hydro          | Jun-11          | No          | 13                      | 0                            |
| Mallarauco                   | 3.4               | Run of the river        | Hydro          | Jun-11          | No          | 12                      | 0                            |
| HBS                          | 2.2               | Biomass/steam           | Biomass        | May-11          | No          | 0                       | 0                            |
| Tomaval                      | NO DATA           | Diesel engine           | Diesel         | May-11          | No          | 3                       | 0                            |
| Carena                       | 10                | Run of the river        | Hydro          | May-11          | No          | 49                      | 0                            |
| Diuto                        | NO DATA           | Run of the river        | Hydro          | May-11          | No          | 5                       | 0                            |
| Los Sauces II                | 1.6               | Diesel engine           | Diesel         | May-11          | No          | 4                       | 835                          |
| Polincay                     | 1.6               | Diesel engine           | Diesel         | Mar-11          | No          | 0                       | 683                          |
| Southern                     | 0.8               | Diesel engine           | Diesel         | Mar-11          | No          | 0                       | 0                            |
| Lautaro                      | 0.8               | Diesel engine           | Diesel         | Mar-11          | No          | 0                       | 991                          |
| Calle Calle                  | 12.8              | Diesel engine           | Diesel         | Feb-11          | No          | 17                      | 832                          |
| <b>Confluencia</b>           | <b>155</b>        | <b>Run of the river</b> | <b>Hydro</b>   | <b>Dec-10</b>   | <b>Yes</b>  | <b>0</b>                | <b>0</b>                     |
| Mariposas                    | 6                 | Run of the river        | Hydro          | Dec-10          | No          | 30                      | 0                            |
| Cem Bio Bio IFO              | 13.6              | Diesel engine           | IFO 180        | Dec-10          | No          | 57                      | 684                          |
| Cem Bio Bio DIESEL           | 13.6              | Diesel engine           | Diesel         | Dec-10          | No          | 0                       | 601                          |
| Cabrero                      | 11                | Biomass/steam           | Biomass        | Nov-10          | Yes         | 0                       | 0                            |
| La Higuera                   | 154.7             | Run of the river        | Hydro          | Sep-10          | Yes         | 0                       | 0                            |
| Juncalito                    | 1.5               | Run of the river        | Hydro          | Sep-10          | No          | 3                       | 0                            |
| El Tartaro                   | 0.14              | Run of the river        | Hydro          | Sep-10          | No          | 0                       | 0                            |
| <b>Guayacán</b>              | <b>12</b>         | <b>Run of the river</b> | <b>Hydro</b>   | <b>Sep-10</b>   | <b>Yes</b>  | <b>0</b>                | <b>0</b>                     |
| Los Corrales                 | 0.8               | Run of the river        | Hydro          | Sep-10          | No          | 3                       | 0                            |
| Carbomet                     | 5.12              | Run of the river        | Hydro          | Aug-10          | No          | 40                      | 0                            |
| El Salvador                  | 23.8              | Open Cycle              | Diesel         | Aug-10          | No          | 0                       | 1279                         |
| <b>San Clemente</b>          | <b>9.5</b>        | <b>Run of the river</b> | <b>Hydro</b>   | <b>Jul-10</b>   | <b>Yes</b>  | <b>0</b>                | <b>0</b>                     |
| Curicó                       | 0                 | Diesel engine           | Diesel         | Jul-10          | No          | 2                       | 0                            |
| Punta Colorada               | 16.3              | Diesel engine           | Diesel         | Jul-10          | No          | 2                       | 630                          |
| Punta Colorada IFO           | 16.3              | Diesel engine           | IFO 180        | Jul-10          | No          | 64                      | 675                          |
| Punta Colorada Diesel        | 16.3              | Diesel engine           | Diesel         | Jul-10          | No          | 2                       | 587                          |
| <b>Trueno</b>                | <b>3.6</b>        | <b>Run of the river</b> | <b>Hydro</b>   | <b>Jun-10</b>   | <b>Yes</b>  | <b>0</b>                | <b>0</b>                     |
| Emelda                       | 72                | Open Cycle              | IFO 180        | Jun-10          | No          | 1                       | 968                          |
| Colihues IFO                 | 22                | Diesel engine           | IFO 180        | Jun-10          | No          | 49                      | 668                          |
| Colihues DIE                 | 22                | Diesel engine           | Diesel         | Jun-10          | No          | 0                       | 0                            |
| Ja Paloma                    | 5.4               | Run of the river        | Hydro          | May-10          | Yes         | 0                       | 0                            |
| Loma Los Colorados           | 14                | Biogas engine           | Biogas         | Apr-10          | Yes         | 0                       | 0                            |
| Guacolda 4                   | 152               | Coal/Steam              | Coal           | Jan-10          | No          | 1124                    | 1126                         |
| Totoral (edilicia)           | 46                | Aeolics                 | Wind           | Jan-10          | Yes         | 0                       | 0                            |
| Monte Redondo                | 48                | Aeolics                 | Wind           | Jan-10          | Yes         | 0                       | 0                            |
| Quintero GNL                 | 240               | Open Cycle              | LNG            | Nov-09          | No          | 171                     | 606                          |
| Canela 2                     | 60                | Aeolics                 | Wind           | Nov-09          | No          | 108                     | 0                            |
| Truful Truful                | 0.5               | Run of the river        | Hydro          | Oct-09          | No          | 2                       | 0                            |
| Nueva Ventanas               | 272               | Coal/Steam              | Coal           | Oct-09          | No          | 1856                    | 934                          |
| Tapihue                      | 6.4               | Diesel engine           | Diesel         | Oct-09          | No          | 2                       | 764                          |
| Termopacifico                | 96                | Diesel engine           | Diesel         | Oct-09          | No          | 49                      | 1013                         |
| San Lorenzo de D. De Almagro | 60                | Diesel engine           | Diesel         | Sep-09          | No          | 0                       | 1080                         |
| Louisiana Pacific            | 2.9               | Diesel engine           | Diesel         | Jul-09          | No          | 1                       | 551                          |
| El Peñón                     | 80                | Diesel engine           | Diesel         | Jul-09          | No          | 169                     | 688                          |
| Pehui                        | 1.1               | Run of the river        | Hydro          | Jun-09          | No          | 7                       | 0                            |
| Biomar                       | 2.4               | Diesel engine           | Diesel         | Jun-09          | No          | 0                       | 696                          |
| Eagon                        | 2.4               | Diesel engine           | Diesel         | Jun-09          | No          | 1                       | 914                          |
| Salmofood I                  | 1.6               | Diesel engine           | Diesel         | Jun-09          | No          | 0                       | 0                            |
| Salmofood II                 | 1.6               | Diesel engine           | Diesel         | Jun-09          | No          | 0                       | 692                          |
| Teno                         | 50                | Diesel engine           | Diesel         | Jun-09          | No          | 113                     | 687                          |
| Newen Propano                | 15                | Open Cycle              | Propane        | Jun-09          | No          | 12                      | 640                          |
| Newen Gas Natural            | 15                | Open Cycle              | Natural Gas    | Jun-09          | No          | 34                      | 623                          |
| Watts                        | 2.64              | Diesel engine           | Diesel         | Jun-09          | No          | 0                       | 292                          |
| Multiexport I                | 1.6               | Diesel engine           | Diesel         | Jun-09          | No          | 0                       | 696                          |
| Multiexport II               | 1.6               | Diesel engine           | Diesel         | Jun-09          | No          | 0                       | 547                          |
| Tierra Amarilla              | 142               | Diesel engine           | Diesel         | Jun-09          | No          | 1                       | 879                          |
| Quintero                     | 240               | Open Cycle              | Diesel         | Jun-09          | No          | 46                      | 822                          |
| <b>Lebu (Cristoro)</b>       | <b>3.6</b>        | <b>Aeolics</b>          | <b>Wind</b>    | <b>Jun-09</b>   | <b>Yes</b>  | <b>0</b>                | <b>0</b>                     |
| Guacolda 3                   | 152               | Coal/Steam              | Coal           | Apr-09          | No          | 1163                    | 1042                         |
| San Gregorio                 | 0.5               | Diesel engine           | Diesel         | Mar-09          | No          | 1                       | 498                          |
| Linares Norte                | 0.5               | Diesel engine           | Diesel         | Mar-09          | No          | 0                       | 496                          |
| Chuyaca                      | 20                | Diesel engine           | Diesel         | Feb-09          | No          | 19                      | 860                          |
| Trapén                       | 90                | Diesel engine           | Diesel         | Feb-09          | No          | 169                     | 687                          |
| Los Espinos                  | 122               | Diesel engine           | Diesel         | Feb-09          | No          | 108                     | 666                          |
| <b>Urcay</b>                 | <b>19</b>         | <b>Run of the river</b> | <b>Hydro</b>   | <b>Jan-09</b>   | <b>Yes</b>  | <b>0</b>                | <b>0</b>                     |
| El Manzano                   | 4.85              | Run of the river        | Hydro          | Dec-08          | Yes         | 0                       | 0                            |
| Santa Lidia                  | 136               | Open Cycle              | Diesel         | Dec-08          | No          | 145                     | 825                          |
| Skretting                    | 2.7               | Diesel engine           | Diesel         | Oct-08          | No          | 0                       | 696                          |
| Cenizas                      | 16.5              | Diesel engine           | Diesel         | Oct-08          | No          | 41                      | 694                          |
| Los Pinos                    | 92.1              | Open Cycle              | Diesel         | Sep-08          | No          | 262                     | 665                          |
| Colmito                      | 55                | Open Cycle              | Diesel         | Aug-08          | No          | 7                       | 933                          |
| Coya                         | 10.8              | Run of the river        | Hydro          | Jul-08          | No          | 69                      | 0                            |
| Chiloé                       | 9                 | Diesel engine           | Diesel         | Jul-08          | No          | 5                       | 858                          |
| Ojos de Agua                 | 9                 | Run of the river        | Hydro          | Jun-08          | Yes         | 0                       | 0                            |
| Puclaro                      | 6                 | Run of the river        | Hydro          | May-08          | Yes         | 0                       | 0                            |
| Totoral                      | 3                 | Open Cycle              | Diesel         | Apr-08          | No          | 2                       | 769                          |
| Quintay                      | 3                 | Open Cycle              | Diesel         | Apr-08          | No          | 3                       | 736                          |
| Placilla                     | 3                 | Open Cycle              | Diesel         | Apr-08          | No          | 1                       | 679                          |
| Olivos                       | 96                | Open Cycle              | Diesel         | Feb-08          | No          | 30                      | 684                          |
| <b>Nueva Aldea 3</b>         | <b>37</b>         | <b>Biomass/steam</b>    | <b>Biomass</b> | <b>Jan-08</b>   | <b>Yes</b>  | <b>0</b>                | <b>0</b>                     |
| Campanario Diesel            | 220               | Open Cycle              | Diesel         | Jan-08          | No          | 69                      | 762                          |
| Quellon II                   | 10                | Diesel engine           | Diesel         | Jan-08          | No          | 22                      | 908                          |
| Palmucho                     | 32                | Run of the river        | Hydro          | Sep-07          | No          | 224                     | 0                            |
| Hornitos                     | 55                | Run of the river        | Hydro          | Sep-07          | Yes         | 0                       | 0                            |
| Canela 1                     | 18.2              | Aeolics                 | Wind           | Sep-07          | Yes         | 0                       | 0                            |

|                         |             |                         |                |               |            |          |          |
|-------------------------|-------------|-------------------------|----------------|---------------|------------|----------|----------|
| Chilbuo                 | 19.4        | Run of the river        | Hydro          | Jul-07        | No         | 67       | 0        |
| Curanilahue             | 2.1         | Diesel engine           | Diesel         | Jul-07        | No         | 0        | 0        |
| Construcción I          | 9           | Diesel engine           | Diesel         | Jul-07        | No         | 6        | 867      |
| Maulé                   | 6           | Diesel engine           | Diesel         | Jul-07        | No         | 3        | 866      |
| Monte Patria            | 9           | Diesel engine           | Diesel         | Jul-07        | No         | 0        | 910      |
| Punitaqui               | 9           | Diesel engine           | Diesel         | Jul-07        | No         | 0        | 885      |
| Degan                   | 39.6        | Diesel engine           | Diesel         | Jul-07        | No         | 81       | 689      |
| <b>Ecuador (ex FPC)</b> | <b>14.2</b> | <b>Biomass/steam</b>    | <b>Biomass</b> | <b>Jun-07</b> | <b>Yes</b> | <b>0</b> | <b>0</b> |
| Esperanza               | 22.2        | Diesel engine           | Diesel         | Jun-07        | No         | 5        | 923      |
| San Isidro II           | 353         | Combined Cycle          | Natural Gas    | Apr-07        | No         | 0        | 0        |
| San Isidro I Diesel     | 353         | Combined Cycle          | Diesel         | Apr-07        | No         | 8        | 574      |
| San Isidro II GNL       | 353         | Combined Cycle          | LNG            | Apr-07        | No         | 3027     | 354      |
| <b>Quilleco</b>         | <b>70.8</b> | <b>Run of the river</b> | <b>Hydro</b>   | <b>Apr-07</b> | <b>Yes</b> | <b>0</b> | <b>0</b> |
| El Rincon               | 0.28        | Run of the river        | Hydro          | Apr-07        | No         | 2        | 0        |
| Casablanca              | 1.2         | Diesel engine           | Diesel         | Apr-07        | No         | 0        | 1402     |
| Las Vegas               | 2           | Diesel engine           | Diesel         | Apr-07        | No         | 2        | 741      |
| Curauima                | 2           | Diesel engine           | Diesel         | Apr-07        | No         | 1        | 1134     |
| Concon                  | 2.2         | Diesel engine           | Diesel         | Apr-07        | No         | 1        | 885      |
| Byzaguirre              | 2.1         | Run of the river        | Hydro          | Mar-07        | No         | 4        | 0        |
| Campanario Gas          | 180         | Open Cycle              | Natural Gas    | Mar-07        | No         | 7        | 92       |
| Los Vientos TG          | 132         | Open Cycle              | Diesel         | Jan-07        | No         | 43       | 923      |
| Cafete                  | 3           | Diesel engine           | Diesel         | Jan-07        | No         | 4        | 870      |
| Los Sauces              | 3           | Diesel engine           | Diesel         | Jan-07        | No         | 2        | 789      |
| Traiguén                | 3           | Diesel engine           | Diesel         | Jan-07        | No         | 3        | 851      |
| Curacautin              | 3           | Diesel engine           | Diesel         | Jan-07        | No         | 2        | 886      |
| Colipulli               | 3           | Diesel engine           | Diesel         | Jan-07        | No         | 1        | 858      |
| Nueva Aldea 2           | 10          | Open Cycle              | Diesel         | 2006          | No         | 0        | 0        |
| Ancud                   | 3.3         | Diesel engine           | Diesel         | 2006          | No         | 2        | 885      |
| Quellon                 | 4.99        | Diesel engine           | Diesel         | 2006          | No         | 3        | 851      |
| Antihue TG              | 101.3       | Open Cycle              | Diesel         | 2005          | No         | 205      | 814      |
| TG_Coronel              | 46.7        | Open Cycle              | Natural Gas    | 2005          | No         | 9        | 517      |
| TG_Coronel Diesel       | 46.7        | Open Cycle              | Diesel         | 2005          | No         | 105      | 874      |
| <b>Nueva Aldea</b>      | <b>14</b>   | <b>Biomass/steam</b>    | <b>Biomass</b> | <b>2005</b>   | <b>Yes</b> | <b>0</b> | <b>0</b> |
| Candelaria              | 253.9       | Open Cycle              | Natural Gas    | 2005          | No         | 11       | 597      |
| Candelaria Diesel       | 253.9       | Open Cycle              | Diesel         | 2005          | No         | 122      | 694      |
| Candelaria GNL          | 253.9       | Open Cycle              | LNG            | 2005          | No         | 319      | 611      |
| L.Verde TG              | 18.8        | Open Cycle              | Diesel         | 2004          | No         | 1        | 1358     |
| Licantén                | 4           | Biomass/steam           | Biomass        | 2004          | No         | 29       | 0        |
| <b>Valdivia</b>         | <b>61</b>   | <b>Biomass/steam</b>    | <b>Biomass</b> | <b>2004</b>   | <b>Yes</b> | <b>0</b> | <b>0</b> |
| Horcones TG             | 24.3        | Open Cycle              | Natural Gas    | 2004          | No         | 0        | 880      |
| Horcones Diesel         | 24.3        | Open Cycle              | Diesel         | 2004          | No         | 12       | 1093     |
| Ralco                   | 690         | Reservoirs              | Hydro          | 2004          | No         | 2440     | 0        |
| Nehuenco II             | 398.3       | Combined Cycle          | Natural Gas    | 2003          | No         | 0        | 0        |
| Nehuenco II Diesel      | 398.3       | Combined Cycle          | Diesel         | 2003          | No         | 497      | 517      |
| Nehuenco II GNL         | 398.3       | Combined Cycle          | LNG            | 2003          | No         | 1301     | 348      |
| <b>Chacabuco</b>        | <b>13</b>   | <b>Biomass</b>          | <b>Biomass</b> | <b>2003</b>   | <b>Yes</b> | <b>0</b> | <b>0</b> |
| Chacabuco               | 25.5        | Run of the river        | Hydro          | 2002          | Yes        | 0        | 0        |
| Nehuenco TG 9B          | 108         | Open Cycle              | Natural Gas    | 2002          | No         | 4        | 597      |
| Nehuenco TG 9B Diesel   | 108         | Open Cycle              | Diesel         | 2002          | No         | 0        | 856      |
| Nehuenco TG 9B GNL      | 108         | Open Cycle              | LNG            | 2002          | No         | 15       | 348      |
| San Fco. Mostazal       | 24          | Open Cycle              | Diesel         | 2002          | No         | 16       | 1088     |
| Peuchén                 | 80          | Run of the river        | Hydro          | 2000          | No         | 221      | 0        |
| Mampul                  | 49          | Run of the river        | Hydro          | 2000          | No         | 158      | 0        |
| Taltal 2 GNL            | 122.45      | Open Cycle              | LNG            | 2000          | No         | 16       | 667      |
| Taltal 1 GNL            | 122.45      | Open Cycle              | LNG            | 2000          | No         | 66       | 632      |
| Taltal                  | 244.9       | Open Cycle              | Diesel         | 2000          | No         | 67       | 914      |
| Rucue                   | 178.4       | Run of the river        | Hydro          | 1998          | No         | 916      | 0        |
| Petroprover             | 75          | Petcoke/steam           | Petcoke        | 1998          | No         | 292      | 928      |
| Nehuenco                | 368.4       | Combined Cycle          | Natural Gas    | 1998          | No         | 0        | 0        |
| Nehuenco Diesel         | 368.4       | Combined Cycle          | Diesel         | 1998          | No         | 782      | 516      |
| Nehuenco GNL            | 368.4       | Combined Cycle          | LNG            | 1998          | No         | 725      | 348      |
| San Isidro              | 379         | Combined Cycle          | Natural Gas    | 1998          | No         | 4        | 376      |
| San Isidro Diesel       | 379         | Combined Cycle          | Diesel         | 1998          | No         | 11       | 564      |
| San Isidro GNL          | 379         | Combined Cycle          | LNG            | 1998          | No         | 2425     | 369      |
| Puntilla                | 22          | Run of the river        | Hydro          | 1997          | No         | 121      | 0        |
| Loma Alta               | 40          | Run of the river        | Hydro          | 1997          | No         | 227      | 0        |
| Nueva Renca GNL         | 379         | Gas                     | LNG            | 1997          | No         | 1720     | 378      |
| Nueva Renca FA          |             | Steam                   | LPG            | 1997          | No         | 1        | 0        |
| Nueva Renca Diesel      | 379         | Combined Cycle          | Diesel         | 1997          | No         | 275      | 645      |
| San Ignacio             | 37          | Run of the river        | Hydro          | 1996          | No         | 171      | 0        |
| Construcción A.         | 8           | Biomass/steam           | Biomass        | 1996          | No         | 37       | 0        |
| <b>Watts</b>            | <b>9</b>    | <b>Biomass/steam</b>    | <b>Biomass</b> | <b>1996</b>   | <b>Yes</b> | <b>0</b> | <b>0</b> |
| Guacolda 2              | 152         | Coal/Steam              | Coal           | 1996          | No         | 944      | 1189     |
| Pangué                  | 467         | Reservoirs              | Hydro          | 1996          | No         | 1717     | 0        |
| Laja                    | 12.7        | Biomass/steam           | Biomass        | 1995-2007     | No         | 42       | 0        |
| Construcción            | 11.1        | Biomass/steam           | Biomass        | 1995-2007     | No         | 49       | 0        |
| Capullo                 | 11          | Run of the river        | Hydro          | 1995          | No         | 69       | 0        |
| Guacolda 1              | 152         | Coal/Steam              | Coal           | 1995          | No         | 1104     | 1246     |
| Aconcagua               | 74          | Run of the river        | Hydro          | 1993          | No         | 292      | 0        |
| Curillilque             | 89          | Run of the river        | Hydro          | 1993          | No         | 483      | 0        |
| Aifaifa                 | 178         | Run of the river        | Hydro          | 1991          | No         | 670      | 0        |
| Pehuénche               |             |                         |                |               |            |          |          |

## **COMBINED MARGIN CALCULATION**

ACCORDING TO ACM0002 v 13.0.0, METHODOLOGICAL TOOL v 3.0.0

OM: Calculated ex post (Option 2, the year in which the emissions occur)  
 BM: Calculated ex-post (Option 2, updated annually from the date the first emissions occur)

|  |                              | 2011          |
|--|------------------------------|---------------|
| Operating Margin                         | (tCO <sub>2</sub> /GWh)      | 721.74        |
| Build Margin                             | (tCO <sub>2</sub> /GWh)      | 653.94        |
| <b>Combined Margin 1st credit period</b> | <b>(tCO<sub>2</sub>/GWh)</b> | <b>687.84</b> |

## **ANNEX 3**

**Methane emission factor of uncontrolled burning of biomass residues from forest operations**

**1. Introduction**

The objective of this project is to quantify the emission factors (EF) of methane (CH<sub>4</sub>) from burning forest residues in the open air, natural, uncontrolled conditions in the south central part of Chile. Two fuel types were burned:

- a) A mixture of sawdust and bark, which are residues from industrial operations (mainly sawmill industry) and are used at Arauco biomass power plants.
- b) A pile of different sizes of branches, which are residues from forestry operations (mainly harvesting, pruning, and thinning).

The mixture of sawdust and bark, collected by third parties, is planned to be used by the Celulosa Arauco y Constitución S.A. (as Arauco) at two new biomass power plants: one in the Horcones Complex, close to Concepcion in the VIII Region, and the other one in the Viñales sawmill, located near Constitución in the VII Region. The same biomass residues are being used by Arauco as fuels at the Nueva Aldea, Trupan, Valdivia, and other biomass power plants. Different sizes of branches (2.5–30 cm in diameter), collected from forestry operations, may also be used as supplemental fuel for the new plants.

We conducted field experiments in south central Chile on March 18–26, 2009, a transition period from late summer to early autumn, to quantify methane and other trace gas emissions from burning the two fuel types mentioned above. We will report the weather conditions, the fuel moisture and carbon content, and the average emission factor of methane (EF CH<sub>4</sub>) with an associated standard deviation for each fuel type burned under natural conditions. We will also discuss the application of the methane emission factors derived from the experiments to calculate the annual amount of methane emissions from burning these fuels in open air.

Our team has a 20-year experience in studying emissions of trace gases from biomass fires in various ecosystems in the United States, Canada, Mexico, the Amazon in Brazil, Chile, Zambia, South Africa, and central Siberia in Russia. Dr. Hao was the co-author of one of the Intergovernmental Panel on Climate Change (IPCC) reports in 2001 [Hao, 2001]. He was recognized by the IPCC for the contribution to the 2007 Nobel Peace Prize to IPCC.

**2. Field Site and Fuel Type**

The experimental site (37°18'54.22"S, 71°59'39.50"W, elevation 310 m) was located at a gravel pit near Canteras in south central Chile. The choice of locating at a gravel pit was to prevent fires spreading to adjacent forests. Eight piles of biomass fuels used at the Arauco's power generating plants were arranged in two rows with four piles on each row and approximately 10 m apart between the piles. Each pile was about 2 m high and had a volume of about 30 m<sup>3</sup>. The fuel types include a mixture of sawdust and bark and branches in different sizes. The description of each pile is summarized in Table 1.

Table 1. Fuel Types of the Experiments

| Fuel Type                       | Identification       | Piles        |
|---------------------------------|----------------------|--------------|
| Mixture of sawdust and bark     | MX4, MX11, MX5, X12  | 4, 5, 11, 12 |
| Branches in different diameters | BR6, BR13, BR7, BR14 | 6, 7, 13, 14 |

**3. Meteorological Conditions**

These experiments were carried out during the transition period from late summer to early autumn. The daily weather conditions at the field site on March 18–26, 2009 are summarized in Table 2. We measured

wind speed, temperature, and relative humidity. The weather conditions during the nine days were fairly constant: sunny, windy, warm, and low humidity almost everyday.

Table 2. Weather Conditions during the Experiments

| Day | March | Condition | Wind Speed (km/hr) | Mean Temperature (°C) | Mean Relative Humidity (%) |
|-----|-------|-----------|--------------------|-----------------------|----------------------------|
| 1   | 18    | sunny     | 7 (2–15)           | 33                    | 24                         |
| 2   | 19    | sunny     | 13 (6–23)          | 24                    | 35                         |
| 3   | 20    | sunny     | 7 (3–22)           | 22                    | 45                         |
| 4   | 21    | sunny     | 8 (5–12)           | 23                    | 31                         |
| 5   | 22    | sunny     |                    |                       |                            |
| 6   | 23    | sunny     | 6 (2–12)           | 23                    | 36                         |
| 7   | 24    | sunny     | 7 (3–20)           | 23                    | 34                         |
| 8   | 25    | sunny     | 8 (4–15)           | 23                    | 42                         |
| 9   | 26    | sunny     | 5 (3–8)            | 21                    | 47                         |

#### 4. Experimental Method

##### 4.1 Combustion Processes

For uncontrolled, open air burning of piled forest residues, a propane torch was used to ignite the piles. The use of fossil fuels, such as diesel or kerosene, for ignition was avoided to prevent contamination of smoke samples. Small tunnels were dug to facilitate air flow in some of the piles. The piles of the sawdust and bark mixture burned for several hours until the combustion process was stabilized and the sampling was initiated. The duration of each pile burned varied considerably. It took several days to burn the piles of mixed sawdust and bark. Windy conditions increased the rate of fuel consumption. Combustion of a pile of sawdust and bark mixture, dominated by prolonged smoldering combustion, is shown in Figure 1. The piles of branches were completely burned within a few hours with predominantly flaming combustion. Combustion of a branch pile is shown in Figure 2.



Figure 1. Burning sawdust and bark mixture shortly after ignition, March 19, 2009



Figure 2. Burning branch pile shortly after ignition on March 20, 2009

## 4.2 Sampling System

Smoke samples were collected every 2–3 hours during daytime. A background sample of clean air was collected at the start of each day, about 100 m upwind from the burning piles. The sampling system was a portable unit mounted on a metal frame that can be carried as a backpack to collect a sample. The inlet of the sampling system was connected to a sample probe (3 m long, 6 mm O.D.) with a flexible 3/8" (O.D.) stainless steel tube. Smoke samples were collected by inserting the sample probe into the smoke about one meter from the pile.

The sampling system consists of a Rasmussen KNF canister pump with 6 mm (O.D.) stainless steel tubing connected through a T-fitting to a pressure relief valve and a pressure gauge, respectively. The pressure relief valve was used to regulate the pressure of the system and set the final pressure in the canisters. The pressure gauge allowed the operator to monitor the pressure change in the canisters while filling the samples and to check that each canister was evacuated prior to sampling. The sampling system was initially purged with smoke, and then the samples were drawn into the canisters by pressuring the canisters to 25 psia. The flow rate into the canisters was 2 liters/minute and it took approximately 30 seconds to fill each canister. The canisters were 500 ml steel bottles with Nupro model SS-00121 stainless steel ball valves. At the end of each sampling, a purge valve opened to flush out the residual sample in the sampling line. The sampling pump was powered by a 12 volt gel cell rechargeable battery.

Based on our previous laboratory tests, the storage time for the low molecular weight trace gases in canisters is longer than six months. Thus, within the time frame of 4–6 weeks between sample collection and analysis, it is reasonable to assume that the concentrations of carbon dioxide (CO<sub>2</sub>), carbon monoxide (CO), CH<sub>4</sub>, and non-methane hydrocarbons (NMHC) in the canisters were stable and did not change during this period.

## 4.3 Fuel Analysis

Samples of about 250 g for each pile were collected prior to ignition for analysis of fuel moisture content. Samples were immediately weighed in the field with a portable balance. After the samples were transported back to the Fire Sciences Laboratory, they were dried for 48 hours at a 100°C oven and weighed [Allen, 1989]. After fuel moisture analysis, a portion of each sample was milled (40 mesh) and sent to the University of Idaho Analytical Services Laboratory for analysis of the carbon content of the biomass by a CHN (carbon-hydrogen-nitrogen) analyzer.

## 4.4 Trace Gas Analysis

Trace gas concentrations in canisters were analyzed at the Fire Sciences Laboratory, using the methodology developed by Hao et al. [1996]. The samples were analyzed for CO<sub>2</sub>, CO, CH<sub>4</sub>, and C<sub>2</sub>, C<sub>3</sub>, and C<sub>4</sub> alkanes and alkenes with a Hewlett Packard model 5890 Series II gas chromatograph equipped with dual flame ionization detectors (FIDs). The CO<sub>2</sub> and CO analysis utilized a 1 ml sample loop to inject the sample onto a 3.2 mm I.D. x 2 m long Carbosphere (Alltech) column, with a helium carrier gas (flow rate - 16 ml/minute). After separation of CO<sub>2</sub> and CO in the column, the compounds were passed through a methanizer (375°C) that converted CO<sub>2</sub> and CO to methane, enabling detection by the FID at 350°C. The oven temperature program for this analysis was 40°C for five minutes, an increase to 140°C at 20°C/minute, and 4 minutes at 140°C. The CH<sub>4</sub> and C<sub>2</sub>–C<sub>4</sub> analyses were performed using a 0.25 ml sample loop, a 0.53 mm x 50 m HP-AL/S column (J&W Scientific), with helium carrier gas at a flow rate of 6 ml/min, and FID at 300°C, with a makeup helium gas flow of 14 ml/min. The oven temperature program for hydrocarbon analysis was the same as the program for CO<sub>2</sub> and CO analysis, as both analyses were performed simultaneously.

Chromatogram data was processed and archived by Hewlett Packard ChemStation II software. A set of CO<sub>2</sub>, CO, CH<sub>4</sub>, and C<sub>2</sub> and C<sub>3</sub> calibration standards at concentrations close to the samples were analyzed each day to construct a standard curve for each compound. Based on the integrated peak areas, the sample concentrations were calculated from the standard curves and written into an Excel spreadsheet. Duplicate samples were analyzed for every sixth analysis. The National Institute of Science and Technology (NIST) primary CO<sub>2</sub> and CO standards were analyzed periodically to verify the response of the detectors. Both the accuracy and precision are 1% for CO<sub>2</sub>, CO, and CH<sub>4</sub> analyses.

The emission factor of a compound is defined as the amount (g) of the compound emitted per kg of biomass burned. The emission factor was calculated by the carbon mass balance method [Ward and Radke, 1993]. The computation was based on the emitted, above-ambient background concentrations of carbon-containing compounds and the carbon content of the biomass. In these experiments, the carbon-containing compounds of CO<sub>2</sub>, CO, CH<sub>4</sub>, and C<sub>2</sub>, C<sub>3</sub>, and C<sub>4</sub> gases were analyzed in the sample, and C<sub>2</sub>–C<sub>4</sub> gases were summed as the non-methane hydrocarbons. High molecular weight hydrocarbons were found in trace concentrations in smoke as compared to the major light carbon compounds (e.g., CO<sub>2</sub>, CO, CH<sub>4</sub>), and accounted for less than 0.01% of the total emitted carbon. Therefore, the omission of measuring the concentrations of high molecular weight hydrocarbons is insignificant in calculating emission factors of methane.

## 5. Results and Discussion

The piles were burned under weather conditions during the transition period from late summer to the beginning of autumn. We collected 51 smoke samples from burning four piles of mixed sawdust and bark, 44 smoke samples from burning four piles of branches in different sizes, and nine clean air samples during the nine-day period. The average moisture content of the mixed fuel of sawdust and bark was 45.5% with a standard deviation of 8.2% (n=4). The average moisture content of branches was extremely low (7.3%) with a standard deviation of 3.2% (n=4). The average carbon content of the mixed fuel and branches was 51.3% ± 0.5% (n=4) and 52.0±1.2% (n=4), respectively. These values are very similar to the default value of wood carbon content of 50%.

Clean air concentrations of 376–422 ppm for CO<sub>2</sub>, 0.1–0.6 ppm for CO, and 1.6–1.8 ppm for CH<sub>4</sub> were comparable to the clean air concentrations measured in other parts of the world. The background concentrations were subtracted from the pile emission concentrations to obtain net emission concentrations.

The emission factor of methane of each sample from burning mixed fuel or branches is shown in Figure 3. The sample number is the order of the samples taken during the nine-day period. It is apparent that the EF CH<sub>4</sub> of mixed fuel (11.6–24.9 g/kg) were much higher than the EF CH<sub>4</sub> of branches (0.1–7.0 g/kg). The EF CH<sub>4</sub> in the first week were slightly higher than the ones in the second week.

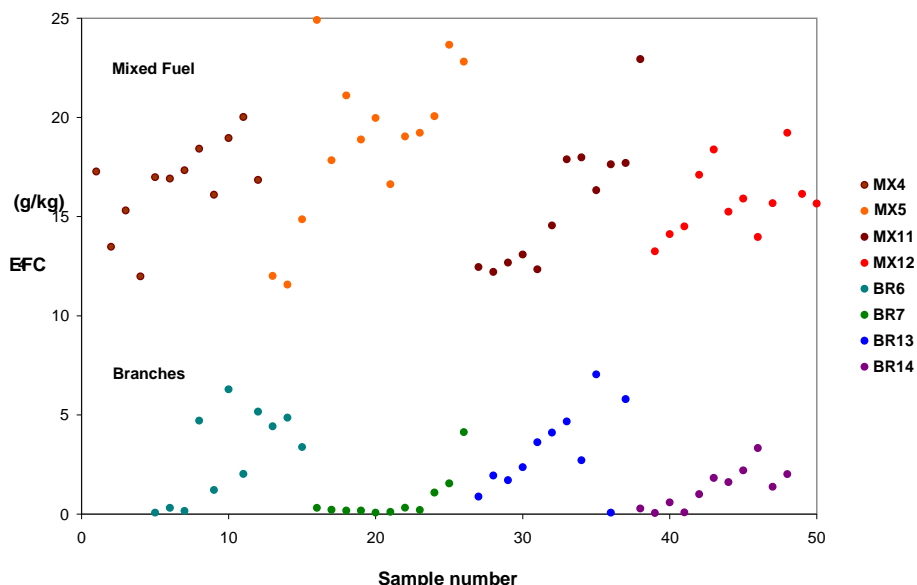

Figure 3. Emission Factor of Methane for Each Sample

The average methane emission factor for each fuel type is summarized in Table 3. The average emission factor of methane from burning mixed sawdust and bark (17.2 g/kg or 930 kg/TJ) is consistent with that for the same type of fuels burned in previous experiments in Chile. The standard deviation ( $\pm 3.1$  g/kg or 168 kg/TJ,  $n=51$ ) is also similar with that of previous measurements carried out in Chile. The average emission factor of methane for burning branches (2.1 g/kg or 114 kg/TJ) is about eight times lower than the EF CH<sub>4</sub> for burning the mixture of sawdust and bark, because burning branches were dominated by high-temperature flaming combustion (Figure 2).

Table 3. Experimental Results

| Fuel Type              | EF CH <sub>4</sub><br>(g/kg) | Standard Deviation<br>(g/kg) | Number of Samples<br>(n) |
|------------------------|------------------------------|------------------------------|--------------------------|
| Mixed sawdust and bark | 17.2                         | 3.1                          | 51                       |
| Branches               | 2.1                          | 2.1                          | 44                       |

or EF CH<sub>4</sub> are equivalent to  $930 \pm 168$  kg CH<sub>4</sub>/TJ for mixed sawdust and bark, and  $114 \pm 114$  kg CH<sub>4</sub>/TJ for branches, based on the net heat content of fuel to be 18.5 MJ/kg measured and provided by Arauco.

The values of the average methane emission factors of burning a mixture of sawdust and bark or branches in different sizes derived from these measurements are very conservative estimates, if the EF CH<sub>4</sub> are used to determine the amount of methane emitted annually from burning these fuels in the open field. These experiments were carried out in warm, dry, windy conditions near the end of the dry season. The moisture content of the biomass is extremely low because of the weather conditions. The weather conditions favor flaming combustion, which result in low methane emissions. When the fuels are burned in the rainy season, the conditions favor smoldering combustion and higher methane emission factors than the values in this report.

## 6. Conclusion

The average emission factor of methane was 17.2 g/kg (or 930 kg CH<sub>4</sub>/TJ), with a standard deviation of 3.1 g/kg (or 167 kg/TJ), from open, uncontrolled burning of four sawdust/bark piles in central Chile in

March 2009. This value was calculated by averaging the measurements of 51 samples collected in nine days. The piles were large enough to represent the combustion process of large piles. The proposition is based on visual observation of the piles burned and the narrow range of the CH<sub>4</sub> emission factors of the experiments. The average methane emission factor was 2.1 g/kg (or 114 kg CH<sub>4</sub>/TJ), with a standard deviation of ±2.1 g/kg (or 114 kg/TJ), for burning four piles of branches in different sizes.

The average methane emission factors derived from these experiments are very conservative values if they are used to calculate the annual methane emissions from burning these fuels in open air. The experiments were conducted in warm, windy, and low humidity weather conditions in nine days. The emissions of methane are expected to be lower under these conditions than the methane emissions in cool, rainy, and high humidity conditions. In addition, digging tunnels, not a common practice, to speed up the experiments also tend to favor flaming combustion and low methane emissions.

The standard deviations of the reported emission factors of methane characterize the natural variability and changes of the combustion process during the duration of the experiments. The standard deviations do NOT represent the variation of the highly reproducible sampling and analytical methods used in this project.

## 7. References

- Allen, S., editor, (1989), *Chemical Analysis of Ecological Materials*, Blackwell Scientific Publications, London.
- Hao, W., D.E. Ward, G. Olbu and S.P. Baker, (1996), Emissions of CO<sub>2</sub>, CO and hydrocarbons from fires in diverse African savanna ecosystems. *Journal of Geophysical Research*, 101(D19), 23577-23584.
- Hao, W.M., (2001), CH<sub>4</sub> and N<sub>2</sub>O emissions from savanna burning and agricultural waste burning: basis for future methodological development. in: *Intergovernmental Panel on Climate Change: Good Practice Guidance and Uncertainty Management in National Greenhouse Gas Inventories*, 4.49-4.52 and 4.84-4.90, World Meteorological Organization, Geneva, Switzerland.
- Ward, D.E., and L.F. Radke, (1993), Emissions Measurements from Vegetation Fires: A Comparative Evaluation of Methods and Results. In: *Fire in the environment: The Ecological, Atmospheric, and Climatic Importance of Vegetation Fires*, Wiley, New

## ANNEX 4

**INFLUENCE AREA OF THE VIÑALES POWER PLANT**

| <b>Communes</b>   | <b>Country region</b> | <b>Communes</b> | <b>Country region</b> |
|-------------------|-----------------------|-----------------|-----------------------|
| Requinoa          | VI                    | Teno            | VII                   |
| Chépica           | VI                    | Vichuquén       | VII                   |
| Coltauco          | VI                    | Talca           | VII                   |
| La Estrella       | VI                    | Constitución    | VII                   |
| Las Cabras        | VI                    | Curepto         | VII                   |
| Litueche          | VI                    | Empedrado       | VII                   |
| Lolol             | VI                    | Maule           | VII                   |
| Malloa            | VI                    | Pelarco         | VII                   |
| Marchihue         | VI                    | Pencahue        | VII                   |
| Nancagua          | VI                    | Río Claro       | VII                   |
| Navidad           | VI                    | San Clemente    | VII                   |
| Palmilla          | VI                    | San Rafael      | VII                   |
| Paredones         | VI                    | Linares         | VII                   |
| Pichidegua        | VI                    | Colbún          | VII                   |
| Placilla          | VI                    | Longaví         | VII                   |
| Pumanque          | VI                    | Parral          | VII                   |
| Quinta de Tilcoco | VI                    | Retiro          | VII                   |
| Rengo             | VI                    | San Javier      | VII                   |
| Santa Cruz        | VI                    | Villa Alegre    | VII                   |
| San Vicente       | VI                    | Yerbas Buenas   | VII                   |
| Peumo             | VI                    | Cauquenes       | VII                   |
| Peralillo         | VI                    | Chanco          | VII                   |
| Curicó            | VII                   | Pelluhue        | VII                   |
| Hualañé           | VII                   | Cobquecura      | VIII                  |
| Licantén          | VII                   | Quirihue        | VIII                  |
| Molina            | VII                   | Ninhue          | VIII                  |
| Rauco             | VII                   | San Carlos      | VIII                  |
| Romeral           | VII                   | Ñiquen          | VIII                  |
| Sagrada Familia   | VII                   |                 |                       |

As stated in this document, this is the geographical region from which all (or most) of the biomass residues will be sourced and therefore, the locations from which the trucks will source the biomass fuels.