



# Verified Carbon Standard

## WIND POWER PROJECT AT THENI BY POWERICA LIMITED



Document Prepared by EKI Energy Services Limited

<b>Project Title</b>	Wind power project at Theni by Powerica Limited
<b>Version</b>	03.1
<b>Report ID</b>	VVER 1830
<b>Date of Issue</b>	05-December-2022
<b>Project ID</b>	1830
<b>Monitoring Period</b>	01-January-2021 to 31-December-2021 (First and last day included)
<b>Prepared By</b>	EKI Energy Services Limited
<b>Contact</b>	Shital Patil Executive Email ID: <a href="mailto:shital@enkingint.org">shital@enkingint.org</a> / <a href="mailto:registry@enkingint.org">registry@enkingint.org</a> Address: Office no. 201, Plot 48, Scheme 78 part 2 Vijay Nagar, Near Brilliant Convention Centre Indore - 452010 (M.P, India) Website <a href="http://www.enkingint.org">www.enkingint.org</a>

## CONTENTS

<b>1</b>	<b>PROJECT DETAILS.....</b>	<b>3</b>
1.1	Summary Description of the Implementation Status of the Project .....	3
1.2	Sectoral Scope and Project Type .....	3
1.3	Project Proponent .....	3
1.4	Other Entities Involved in the Project .....	4
1.5	Project Start Date .....	4
1.6	Project Crediting Period .....	4
1.7	Project Location .....	4
1.8	Title and Reference of Methodology .....	5
1.9	Participation under other GHG Programs .....	6
1.10	Other Forms of Credit.....	6
1.11	Sustainable Development Contributions .....	7
<b>2</b>	<b>SAFEGUARDS .....</b>	<b>9</b>
2.1	No Net Harm .....	9
2.2	Local Stakeholder Consultation .....	9
2.3	AFOLU-Specific Safeguards .....	9
<b>3</b>	<b>IMPLEMENTATION STATUS .....</b>	<b>9</b>
3.1	Implementation Status of the Project Activity .....	9
3.2	Deviations .....	11
3.3	Grouped Projects .....	12
<b>4</b>	<b>DATA AND PARAMETERS.....</b>	<b>12</b>
4.1	Data and Parameters Available at Validation .....	12
4.2	Data and Parameters Monitored.....	13
4.3	Monitoring Plan.....	14
<b>5</b>	<b>QUANTIFICATION OF GHG EMISSION REDUCTIONS AND REMOVALS .....</b>	<b>16</b>
5.1	Baseline Emissions .....	17
5.2	Project Emissions .....	17
5.3	Leakage.....	17
5.4	Net GHG Emission Reductions and Removals.....	17
	<b>APPENDIX 1: ENERGY METER CALIBRATION DETAILS .....</b>	<b>19</b>

# 1 PROJECT DETAILS

## 1.1 Summary Description of the Implementation Status of the Project

The project activity involves an installation of 6 Wind Turbine Generators (WTG) of total generating capacity of 9.9 MW (6 units of Vestas make V82 WTG). The WTG units are installed in Theni district in the state of Tamilnadu, India. The main purpose of the project activity is to generate electrical energy through sustainable means using wind power resources and to contribute to climate change mitigation efforts. In the absence of the project activity, the electricity thus supplied would have been generated through fossil fuel based thermal power plants. The project activity thus contributes to reduction in specific emissions (emissions of pollutant) including GHG emissions. The project activity is also responsible for sustainable economic growth and conservation of environment through use of wind as a renewable source. The project is located in Tamil Nadu state and each WTG have separate feeder and separate meter.

The project activity is a Greenfield project for generation of electrical energy using wind which is a renewable source of energy. Thus, this project actually displaces the electricity grid which is essentially fossil-fuel based.

The start date of the project activity is 13-September-2010, which is the date of commissioning of the first WTG. The project has been operational since the commissioning and has contributed to reduction in greenhouse gas emissions.

Total GHG emissions reductions achieved during the current monitoring period 01-January-2021 to 31-December-2021 are 15,598 tCO<sub>2</sub>e as the result of supplying 16,560.26 MWh electricity that would otherwise have been provided by fossil-fuel dominated grid.

## 1.2 Sectoral Scope and Project Type

Sectoral Scope 1: Energy Industries (renewable/non- renewable sources)

Project type : Renewable energy project (wind)

The project activity is not a grouped project.

## 1.3 Project Proponent

<b>Organization name</b>	Powerica Limited
<b>Contact person</b>	Mr. Pradeep Gupta
<b>Title</b>	Head - Wind Energy Division
<b>Address</b>	9 <sup>th</sup> Floor, Godrej Coliseum, Sion (E) Mumbai – 400022, Maharashtra, India

<b>Telephone</b>	+ 91 22 4001 2000
<b>Email</b>	<a href="mailto:pradeep.gupta@powericaltd.com">pradeep.gupta@powericaltd.com</a>

## 1.4 Other Entities Involved in the Project

<b>Organization name</b>	EKI Energy Services Limited
<b>Role in the Project</b>	Project Consultant
<b>Contact person</b>	Shital Patil
<b>Title</b>	Executive
<b>Address</b>	Office No 201, Plot No 48, Scheme 78, Vijay Nagar Part- II, Indore 452010, India
<b>Telephone</b>	+91-7972836470
<b>Email</b>	<a href="mailto:shital@enkingint.org">shital@enkingint.org</a> / <a href="mailto:registry@enkingint.org">registry@enkingint.org</a>

## 1.5 Project Start Date

The project start date is 13-September-2010 which is the date of commissioning of the first phase of the 9.9 MW wind power project.

## 1.6 Project Crediting Period

The crediting period of the project activity is for 10 years (Renewable).

The length of the second crediting period is 13-September-2020 to 12- September-2030 (both dates inclusive).

## 1.7 Project Location

The project activity located in Taluka: Andipatti, District: Theni, State: Tamilnadu.

The project location is attached in the figure below:

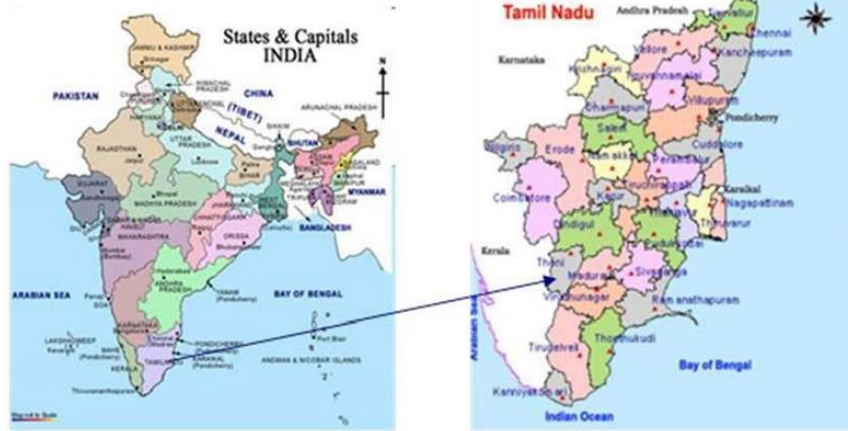

Note: Map not drawn to scale

The unique location information of the WTG is provided in the table below. The WTG numbers indicated in the table below are unique identification number provided by the state utility.

Google map link:

<https://www.google.com/maps/d/viewer?mid=1rjN4PB1S2zhAWPzxaMHD7nu3LZcGGYDA&usp=sharing>

The geo-coordinates of each WTG are as follows:

WTG No.	HTSC No.	Latitude	Longitude	Village
TSSP1255	T-144	9° 59' 40"	77° 34' 10"	Shanmuga- Sundarapuram
TM721	T-141	9° 58' 46"	77° 34' 43"	Mottanuthu
TSSP158	T-142	9° 59' 08"	77° 34' 39"	Shanmuga- Sundarapuram
TM41	T-145	9° 58' 34"	77° 35' 24"	Mottanuthu
TGU28	T-139	9° 57' 03"	77° 33' 33"	Usilampatti
TSSP174	T-143	9° 59' 23"	77° 34' 43"	Shanmuga- Sundarapuram

## 1.8 Title and Reference of Methodology

Methodology Number: AMS –I.D.

**Title:** - “Grid connected renewable electricity generation”, Version 18<sup>1</sup>

Sectoral scope: 1

<sup>1</sup> <https://cdm.unfccc.int/methodologies/DB/W3TINZ7KKWCK7L8WTFQOQFQQH4SBK>

The methodology AMS – I.D. also refers to the latest approved versions of the following tools:

- Tool to calculate the emission factor for an electricity system, (Version 07.0 ,EB 100, Annex 04)<sup>2</sup>
- Assessment of the validity of the original/current baseline and update of the baseline at the renewal of the crediting period, (EB 66, version 03.0.1)<sup>3</sup>

Reference: Appendix B of simplified M&P for small scale project activities (UNFCCC, Recent norms)

As the project activity do not cause any project or leakage emissions from fossil fuel combustion, the “Tool to calculate project or leakage CO<sub>2</sub> emissions from fossil fuel combustion” has not been used in the PDD.

## 1.9 Participation under other GHG Programs

The project activity has also been registration with UNFCCC under Clean Development Mechanism (CDM) program, Registration reference number is 4572<sup>4</sup>.

The Project is not rejected by any other GHG programs.

Details of the credits issued under CDM and VCS mechanism mentioned in below table

Mechanism	Period
13-September-2010 to 30-April-2011	VCS
01-May-2011 to 10-September-2011	CDM
11-September-2011 to 10-December-2012	CDM
11-December-2012 to 10-September-2018	VCS
11-September-2018 to 31-December-2019	VCS
01-January-2020 to 31-December-2020	VCS

## 1.10 Other Forms of Credit

India is Non-annex1 country and there is no compliance with an emission trading program or to meet binding limits on GHG emissions for this project activity. The project is registered under CDM and UNFCCC (Registration ID 4572). The project proponent (PP) has submitted undertaking that they will not claim same GHG emission reductions of the project from CDM and VCS. PP

<sup>2</sup> <https://cdm.unfccc.int/methodologies/PAMethodologies/tools/am-tool-07-v7.0.pdf>

<sup>3</sup> <https://cdm.unfccc.int/methodologies/PAMethodologies/tools/am-tool-11-v3.0.1.pdf>

<sup>4</sup> <https://cdm.unfccc.int/Projects/DB/LRQA%20Ltd1300097036.88/view>

would not use net GHG emission reductions by the projects for compliance with emission trading program to meet binding limits on GHG emissions. PP has also submitted undertaking for not availing other forms of environmental credit for the same crediting period under consideration.

## 1.11 Sustainable Development Contributions

The Designated National Authority (DNA) for the Government of India (GoI) on the Ministry of Environment and Forestry (MoEF)<sup>5</sup>, called the National CDM Authority (NCDMA), has stipulated four indicators on sustainable development for Clean Development Mechanism (CDM) projects structured in India. The project participants' view on the contribution of this project activity towards sustainable development follows these four indicators as explained below:

### Social well-being:

- **Generating Local Employment:** The installation of wind power project in rural areas will result in generating local employment opportunities and capacity building of the local employees. The project activity would create both direct and indirect employment throughout the life-cycle of the project activity.
- **Encouragement to entrepreneurs:** The project will provide encouragement to other entrepreneurs to invest into renewable energy sources.

### Economic well-being:

- **Rural Development:** The installation of wind power project will result in rural and infrastructural development in the surrounding rural areas
- **Economic Development:** The generation of wind power will result in improvising the reliability of the NEWNE Grid and thereby enhance economic development in the region.

### Environment well-being:

- **Reduction in the consumption of fossil fuels:** The installation of power plant generating electricity through renewable resource such as wind power, would lead to reduction in usage of fossil fuels e.g. Coal, oil, natural gas.
- **Reduction in GHG emissions:** The reduction in usage of fossil fuels for electricity generation will result in reduction of the release of associated GHG emissions (CO<sub>2</sub> and CH<sub>4</sub> emissions).
- **Improvement of Air Quality:** The use of renewable energy for power generation will avoid the emission of air pollutants such as Suspended Particulate Matter (SPM), Sulphur Dioxide (SO<sub>2</sub>) and Nitrogen Oxides (NO<sub>x</sub>) thereby improvising the surrounding air quality
- **Conservation of Natural Resources:** Installation of wind power plant will result in conserving fast depleting natural resources such as coal, oil etc.

### Technological well-being:

---

<sup>5</sup> Since June 2014, the name of DNA changed to Ministry of Environment, Forest and Climate Change (MoEFCC)

- **Advanced Technology:** The project activity involves installation and operation of state-of-art wind turbine generators (WTGs) of Vestas make. The implementation of these new technologies will help in increasing reliability of renewable energy generation and encourage development of even better technology in the future.
- **Safe and Sound Technology:** The project activity deploys the technology, which is environmentally safe and sound, as it does not produce greenhouse gases and any toxic or radioactive waste.

### **Sustainable Development Contributions**

According to the Appendix 2- the document history mentioned in the VCS Standard Version 4.2. (latest version), it is clearly mentioned that Project Proponent is required to demonstrate contributions to a minimum of three SDGs, effective immediately for all projects registered on or after 20 January 2023. Since this is the 5th Verification of this project and it is registered before 20 January 2023, SDG reporting is not required for the current version and the PP will demonstrate contribution to at least three SDGs by 20 January 2025.

## 2 SAFEGUARDS

### 2.1 No Net Harm

Please refer to D 1 and D 2 of PDD (version 5.1 dated 08/11/2019) of the UNFCCC registered CDM project with reference no. 4572.

The web link of the same is given below:

<https://cdm.unfccc.int/Projects/DB/LRQA%20Ltd1300097036.88/view>

### 2.2 Local Stakeholder Consultation

Please refer to E 1 and E 2 of PDD (version 5.1 dated 08/11/2019) of the UNFCCC registered CDM project with reference no. 4572.

The web link of the same is given below:

<https://cdm.unfccc.int/Projects/DB/LRQA%20Ltd1300097036.88/view>

The process of local stakeholder consultation is continuous. During the current monitoring period, the project proponent has kept grievance register in plant site office and sought comments/grievances/suggestions from local stakeholders including local community, government agencies and NGOs. However, no major comments/grievances/suggestions have been received from the aforementioned stakeholders during the current monitoring period and all such minor suggestions have been take care by the PP, The same approached will be followed during second crediting period of the project activity.

### 2.3 AFOLU-Specific Safeguards

Not Applicable

## 3 IMPLEMENTATION STATUS

### 3.1 Implementation Status of the Project Activity

It is to be noted that the project activity is a greenfield project for generation of electrical energy using wind which is a renewable source of energy. Thus, this project actually displaces the electricity grid which is essentially fossil-fuel based.

In wind energy generation, kinetic energy of the wind is converted into mechanical energy and subsequently into electrical energy. Wind turbines capture the wind's energy with three propeller-like blades, which are mounted on a rotor, to generate electricity. The turbines sit high atop towers, taking advantage of the stronger and less turbulent wind. As the wind blows through the

blades of the windmill, a pocket of low-pressure air forms on the downwind side of the blade. The low-pressure air pocket then pulls the blade towards it, causing the rotor to spin. The rotor turns the shaft that further spins the connected generator. The spinning of this generator produces the required electricity. Since power is generated from wind energy, no emissions are attributed to the project emissions and emissions due to fossil-fuel based grid has been displaced due to the project activity.

Emission reductions will be claimed on the net electrical energy that is supplied to grid which will be metered using main meter located at the electrical yard of the respective WTGs. These electrical energy meters are essentially electronic tri-vector meters of accuracy class 0.5. Since these meters are not designed to measure high voltages and currents as generated in the WTG, the WTG output is connected to these meters via transformers (CT/PT) for stepping down the generated voltage and current to ranges which the meters can record. As such, these meters have a multiplying factor which when multiplied to the meter reading provides the actual amount of electricity generated. The technology providers for the project have additionally installed an LCS meter at the WTG controller.

V82\_1.65 MW\_50Hz:

Lifetime	20 years
Rated Power	1,650 kW
Rotor diameter	82 m
Swept area	5,281 m <sup>2</sup>
No. of blades	3
Cut in wind speed	3.5 m/s
Cut out wind Speed	25 m/s
Rotor Speed	14.4 rpm
Regulation	Active-Stall
Hub Height	78 m
Generator Type	Asynchronous
Insulation	Class F

The WTGs are under operation since the date of commissioning and no event has been identified which may impact GHG emission reduction. The commissioning dates of all the WTGs are provided as below.

Total GHG emissions reductions achieved during the current monitoring period 01-January-2021 to 31-December-2021 are 15,598 tCO<sub>2</sub>e as the result of supplying 16,560.26 MWh electricity that would otherwise have been provided by fossil-fuel dominated grid.

WTG No.	Location	Date of commissioning
TSSP 1255	Shanmuga-Sundarapuram	13-September-2010
TM 721	Mottanuthu	13-September-2010
TSSP 158	Shanmuga-Sundarapuram	13-September-2010
TM 41	Mottanuthu	17-September-2010
TGU 28	Usilampatti	13-September-2010
TSSP 174	Shanmuga-Sundarapuram	13-September-2010

## 3.2 Deviations

### 3.2.1 Methodology Deviations

There is no any methodology deviation applicable for the project activity.

### 3.2.2 Project Description Deviations

This project deviation was approved during renewal of crediting period (Monitoring period from 01-January-2020 to 31-December-2020).

As per registered CDM PDD, the calibration frequency is once in every two years. The calibration of meters is not in control of PP and same is done by state electricity board. The state electricity board does not follow any fixed calibration frequency; hence deviation is requested for change in calibration frequency as once in five years. This calibration frequency is as per CEA notification.

The change in calibration frequency does not have any impact on ER calculations as during monthly reading state electricity board official and PP representative check the meter conditions.

Also both parties accepts the reading and PP raise the invoice to state electricity board based on monthly JMR reading. Thus financial obligations are involved which ensures that meters are running accurately.

The deviation is in accordance with the existing national regulation for testing of meters (monitoring equipment) in the host country and the monitoring parameter thus measured is cross-checked by invoices issued by state electricity transmission utility. Hence the deviation does not have any impact of value of monitored parameter and thus on the value of GHG emission reductions. Thus the deviation does not impact the applicability of the methodology, additionality or the appropriateness of the baseline scenario of the project activity.

### 3.3 Grouped Projects

This is not a grouped project activity.

## 4 DATA AND PARAMETERS

### 4.1 Data and Parameters Available at Validation

<b>Data / Parameter</b>	<b>EF<sub>grid,OM,y</sub></b>
<b>Data unit</b>	tCO <sub>2</sub> /MWh
<b>Description</b>	Operating Margin CO <sub>2</sub> emission factor in year y
<b>Source of data</b>	Calculated from CEA database, Version 15, Dec 2019 <sup>6</sup>
<b>Value applied</b>	0.9622
<b>Justification of choice of data or description of measurement methods and procedures applied</b>	Calculated as the last 3 year (2016-17, 2017-18, 2018-19) generation-weighted average, sourced from Baseline CO <sub>2</sub> Emission Database, Version 15.0, Dec 2019 published by Central Electricity Authority (CEA), Government of India.
<b>Purpose of Data</b>	For the calculation of the Baseline Emission
<b>Comments</b>	This parameter is fixed ex-ante for the entire crediting period

<b>Data / Parameter</b>	<b>EF<sub>grid,BM,y</sub></b>
<b>Data unit</b>	tCO <sub>2</sub> /MWh
<b>Description</b>	Build Margin CO <sub>2</sub> emission factor in year y
<b>Source of data</b>	Calculated from CEA database, Version 15, Dec 2019 <sup>7</sup>
<b>Value applied</b>	0.8811
<b>Justification of choice of data or description of measurement methods and procedures applied</b>	Calculated as per “Tool to calculate the emission factor for an electricity system, version 07” as per the latest data available for the most recent year 2018-19. The data is obtained from “CO <sub>2</sub> Baseline Database for Indian Power Sector” version 15, published by the Central Electricity Authority, Ministry of Power, and Government of India.
<b>Purpose of Data</b>	For the calculation of the Baseline Emission
<b>Comments</b>	This parameter is fixed ex-ante for the entire crediting period.

<sup>6</sup> [http://www.cea.nic.in/reports/others/thermal/tpece/cdm\\_co2/user\\_guide\\_ver15.pdf](http://www.cea.nic.in/reports/others/thermal/tpece/cdm_co2/user_guide_ver15.pdf)

<sup>7</sup> [http://www.cea.nic.in/reports/others/thermal/tpece/cdm\\_co2/user\\_guide\\_ver15.pdf](http://www.cea.nic.in/reports/others/thermal/tpece/cdm_co2/user_guide_ver15.pdf)

Data / Parameter	$EF_{grid,CM,y}$
Data unit	tCO <sub>2</sub> /MWh
Description	Combined Margin CO <sub>2</sub> emission factor in year y
Source of data	Calculated from CEA database, Version 15, Dec 2019 <sup>8</sup>
Value applied	0.9419
Justification of choice of data or description of measurement methods and procedures applied	<p>The combined margin emissions factor is calculated as follows:</p> $EF_{grid,CM,y} = EF_{grid,OM,y} * W_{OM} + EF_{grid,BM,y} * W_{BM}$ <p>Where:</p> <p><math>EF_{grid,BM,y}</math> = Build margin CO<sub>2</sub> emission factor in year y (tCO<sub>2</sub>/MWh)  <math>EF_{grid,OM,y}</math> = Operating margin CO<sub>2</sub> emission factor in year y (tCO<sub>2</sub>/MWh)  <math>W_{OM}</math> = Weighting of operating margin emissions factor (%) = 75%  <math>W_{BM}</math> = Weighting of build margin emissions factor (%) = 25%</p>
Purpose of Data	For the calculation of the Baseline Emission
Comments	This parameter is fixed ex-ante for the entire crediting period.

## 4.2 Data and Parameters Monitored

Data / Parameter	$EG_y$
Data unit	MWh/year
Description	Quantity of net electricity supplied to the grid in year y
Source of data	TNEB Statement
Description of measurement methods and procedures to be applied	<p><u>Monitoring</u>: Electrical Energy Meters which are electronic tri-vector meters</p> <p><u>Data type</u>: Measured &amp; Calculated</p> <p><u>Archiving</u>: Paper &amp; Electronic <u>Recording Frequency</u>: Monthly</p> <p><u>Responsibility</u>: The O&amp;M site-in-charge shall be responsible for the regular recording of data.</p> <p><u>Calibration Frequency</u>: The meters shall be calibrated once every five years. as per CEA (installation and operation of meters) (Amendment) Regulations, 2019</p> <p>Web-link: <a href="https://cea.nic.in/regulations-category/metering-regulations/?lang=en">https://cea.nic.in/regulations-category/metering-regulations/?lang=en</a></p>

<sup>8</sup> [http://www.cea.nic.in/reports/others/thermal/tpece/cdm\\_co2/user\\_guide\\_ver15.pdf](http://www.cea.nic.in/reports/others/thermal/tpece/cdm_co2/user_guide_ver15.pdf)

Frequency of monitoring/recording	Continuous monitoring and monthly recording														
Value monitored	16,560.26														
Monitoring equipment	<p><b>Monitoring Equipment:</b> Electrical Energy Meters which are electronic tri-vector meters.</p> <p>Accuracy: 0.5s</p> <p>Make: HPL</p> <p>Details of energy meters are given below:</p> <table border="1" style="width: 100%; border-collapse: collapse;"> <thead> <tr> <th style="width: 50%;">WTG No.</th> <th style="width: 50%;">Meter Serial No.</th> </tr> </thead> <tbody> <tr> <td>TGU 28 SS(T-139)</td> <td>627560</td> </tr> <tr> <td>TM 41 SS(T-145)</td> <td>624763</td> </tr> <tr> <td>TSSP 158 SS(T-142)</td> <td>624852</td> </tr> <tr> <td>TSSP 174 SS(T-143)</td> <td>627558</td> </tr> <tr> <td>TM 721 SS(T-141)</td> <td>627555</td> </tr> <tr> <td>TSSP 1225 SS(T-144)</td> <td>627553</td> </tr> </tbody> </table>	WTG No.	Meter Serial No.	TGU 28 SS(T-139)	627560	TM 41 SS(T-145)	624763	TSSP 158 SS(T-142)	624852	TSSP 174 SS(T-143)	627558	TM 721 SS(T-141)	627555	TSSP 1225 SS(T-144)	627553
WTG No.	Meter Serial No.														
TGU 28 SS(T-139)	627560														
TM 41 SS(T-145)	624763														
TSSP 158 SS(T-142)	624852														
TSSP 174 SS(T-143)	627558														
TM 721 SS(T-141)	627555														
TSSP 1225 SS(T-144)	627553														
QA/QC procedures to be applied	<p>The amount of electricity exported to grid is cross-checked with the invoices for sale of power.</p> <p>Meter calibration shall be conducted once in every five years and internal audit system is in place.</p> <p>(Meter calibration details are available in Appendix -1)</p>														
Purpose of the data	Calculation of baseline emissions														
Calculation method	--														
Comments	The Monitored Data to be kept for a minimum of two years after the end of the crediting period or the last issuance whichever is later.														

### 4.3 Monitoring Plan

The monitoring methodology specified in the methodology requires that the project- monitoring plan to consist of metering the electricity generated by the renewable technology. In order to monitor the mitigation of GHG due to the project activity, the total energy exported needs to be measured. The net energy supplied to grid by the project activity multiplied by emission factor for

regional grid, would form the baseline emission to the project activity. Since the baseline methodology is based on ex-ante determination of the baseline emission factor, the monitoring of baseline emission factor is not required. The sole parameter for monitoring is the electricity exported to the grid. The Project is operated and managed by Vestas Wind Technology India Private Limited (Vestas). Vestas will have a designated Site-In-Charge (O&M) on site who will be responsible for monitoring the electricity exported from the project activity. The overall flow of information has been depicted using the following *hierarchical* structure:

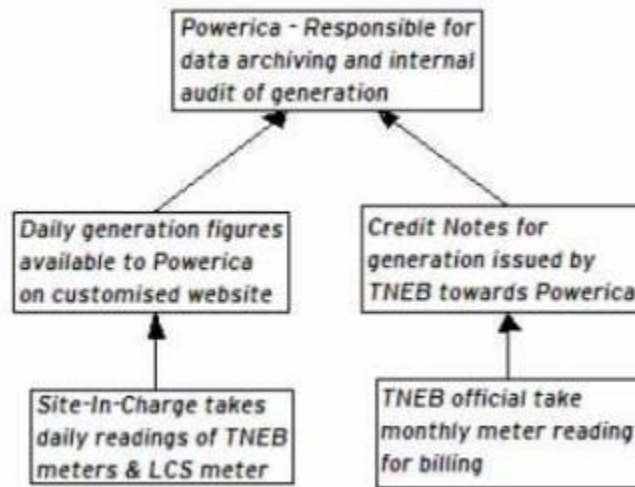

There are two points of monitoring:

- At the WTG panel by LCS meter provided by O&M service provider
- At the WTG electrical yard substation using a TNEB owned electronic tri-vector meters

The net electricity exported to grid is calculated as the product of difference of current and previous TNEB meter readings multiplied with the multiplying factor of the meter. Additionally, all the WTGs at the site are connected to a central monitoring system located at that site only. This system captures daily generation figures which are later made available to Powerica on the customized website of Vestas.

### Emergency Preparedness

In the context of the project activity, the meters will be kept in sealed by TNEB and all maintenance will be taken up by TNEB only. In case of failure of the main meter, generation value of controller meter would be considered. The previous month's transmission loss between the main meter and controller meter would be taken into account to determine net electricity supplied to grid. There was no any such instance occurred where main meter is failed during current monitoring period. The state electricity board has removed check meters, hence only main meters are part of project activity. The monitoring process is under control of state electricity board and PP do not have any control on it.

The schematic line diagram of metering point are as below where project activity uses only main meter for determination of net electricity supplied to grid.

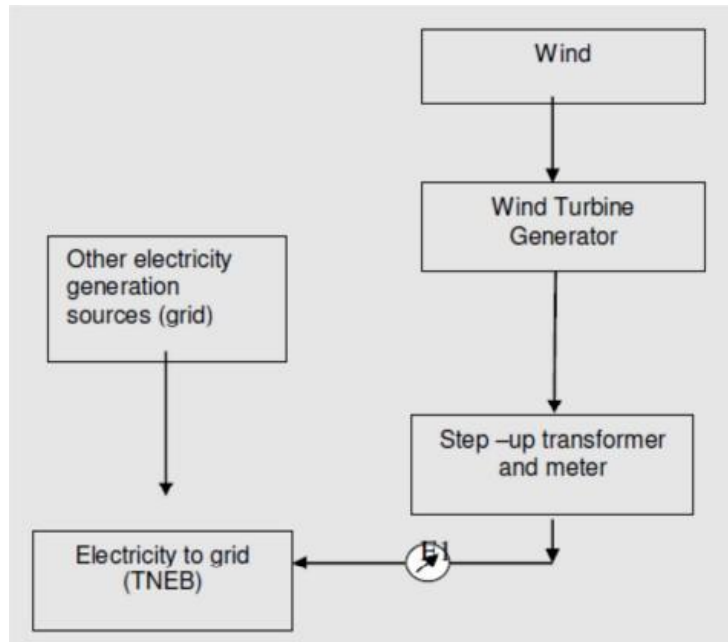

The project promoters have contracted the technology supplier for providing O&M services for the power project. The service provider would be responsible for maintenance of the necessary spare parts and consumables for the maintenance of the WTGs such as anemometers, wind vanes and sensors, oil filters, batteries, auxiliary motors and pumps, WTG controllers, slip rings, limit switches and sensors, detergents & solvents etc. The service provider would also be responsible for supply of necessary main components of the WTG such as main gearboxes, blades, generators, towers, hubs, main shafts & bearings, ground and top controller and hydraulic systems. The service provider would also ensure that occupational health and safety procedures are adhered to during the operation & maintenance activities. Additionally, spare meters would also be kept available at the site for replacement in case of failure of any of the monitoring equipment

## 5 QUANTIFICATION OF GHG EMISSION REDUCTIONS AND REMOVALS

## 5.1 Baseline Emissions

Baseline emissions are calculated by multiplying the Net electricity exported to the grid with net baseline emission factor, as given in the registered VCS PD.

$$BE_y = EG_{,y} \times EF_{grid,CM,y}$$

Where,

$BE_y$  = Baseline Emissions (tCO<sub>2</sub>/year)

$EG_{,y}$  = Net electricity supplied to the grid in year y (MWh)

$EF_{grid, CM, y}$  = Baseline Emission Factor (Combined margin CO<sub>2</sub> emission factor for grid)

The calculation of yearly baseline emissions is provided below:

$$\begin{aligned} BE_y &= 16,560.26 * 0.9419 \\ &= 15,598 \text{ tCO}_2 \end{aligned}$$

## 5.2 Project Emissions

No project emissions are applicable to this wind electric power project, since the electricity generation is based on wind resources, which does not involve in combustion or generation of emissions from fossil fuels. Hence, these emission sources are neglected.

$$PE_y = 0$$

## 5.3 Leakage

No leakage emissions are considered. The main emissions potentially giving rise to leakage in the context of electric sector projects are emissions arising due to activities such as power plant construction and upstream emissions from fossil fuel use (e.g. extraction, processing, and transport). These emission sources are neglected.

$$LE_y = 0$$

## 5.4 Net GHG Emission Reductions and Removals

The Formula used to calculate the net emission reduction for the project activity is

$$ER_y = BE_y - PE_y - LE_y$$

Where,

$ER_y$  = Emission Reduction in tCO<sub>2</sub>/year

$BE_y$  = Baseline emission in tCO<sub>2</sub>/year

$PE_y$  = Project emissions in tCO<sub>2</sub>/year

$LE_y$  = Leakage Emissions in tCO<sub>2</sub>/year

For the project activity during the current monitoring period, as per section 6.2,

BE<sub>y</sub> = 15,598 tCO<sub>2e</sub>, PE<sub>y</sub> = 0 tCO<sub>2e</sub> , LE<sub>y</sub> = 0 tCO<sub>2e</sub>.

Year	Baseline emissions or removals (tCO <sub>2e</sub> )	Project emissions or removals (tCO <sub>2e</sub> )	Leakage emissions (tCO <sub>2e</sub> )	Net GHG emission reductions or removals (tCO <sub>2e</sub> )
01-January-2021 to 31-December-2021	15,598	0	0	15,598
<b>Total</b>	15,598	0	0	15,598

During the current monitoring period, actual emission reductions achieved are 15,598 tCO<sub>2e</sub> whereas estimated emission reductions was 22,735 tCO<sub>2e</sub>. The project witnessed a decrease of 31.39 % in emission reductions as compared to ex-ante emissions.

# APPENDIX 1: ENERGY METER CALIBRATION DETAILS

WTG No.	Meter Serial No.	Make	Accuracy class	Last Calibration date	Next due date of Calibration
TGU 28 SS(T-139)	627560	HPL	0.5s	17-May-2017	16-May-2022
TM 41 SS(T-145)	624763	HPL	0.5s	17-May-2017	16-May-2022
TSSP 158 SS(T-142)	624852	HPL	0.5s	17-May-2017	16-May-2022
TSSP 174 SS(T-143)	627558	HPL	0.5s	17-May-2017	16-May-2022
TM 721 SS(T-141)	627555	HPL	0.5s	17-May-2017	16-May-2022
TSSP 1225 SS(T-144)	627553	HPL	0.5s	17-May-2017	16-May-2022

Earlier there were check meters also installed as back up meters, however state electricity board had removed that check meters and only main meters are used for export, import values. Hence that main meters are mentioned in above table.

As per registered CDM PDD, the calibration frequency is once in every two years. The calibration of meters is not in control of PP and same is done by state electricity board. The state electricity board does not follow any fixed calibration frequency, hence deviation is requested for change in calibration frequency as once in five years and this deviation request was approved during the previous verification. This calibration frequency is as per CEA notification, CEA (installation and operation of meters) (Amendment) Regulations, 2019

<https://cea.nic.in/regulations-category/metering-regulations/?lang=en>

Based on once in five year calibration frequency as per requested deviation, there is no any delay in calibration and no error factor is applicable for current monitoring period.