



# Verified Carbon Standard

## WIND POWER PROJECT IN RAJASTHAN



India's Largest Carbon Credit Developer & Supplier

Document Prepared by EKI Energy Services Limited

<b>Project Title</b>	Wind power project in Rajasthan
<b>Version</b>	02
<b>Report ID</b>	01
<b>Date of Issue</b>	07-07-2020
<b>Project ID</b>	1195
<b>Monitoring Period</b>	01-06-2018 to 05-12-2019 (inclusive of both days)
<b>Prepared By</b>	EKI Energy Services Limited
<b>Contact</b>	Anjali Rao Project Manager Email ID : anjali@enkingint,.org T +91 731 42 89 086, M +91 9109120940 Address: Office no. 201, Plot 48, Scheme 78 part 2 Vijay Nagar, Near Brilliant Convention Centre Indore - 452010 (M.P, India) Website www.enkingint.org

## CONTENTS

<b>1</b>	<b>PROJECT DETAILS.....</b>	<b>3</b>
1.1	Summary Description of the Implementation Status of the Project.....	3
1.2	Sectoral Scope and Project Type.....	3
1.3	Project Proponent .....	3
1.4	Other Entities Involved in the Project .....	4
1.5	Project Start Date .....	4
1.6	Project Crediting Period .....	4
1.7	Project Location.....	4
1.8	Title and Reference of Methodology .....	6
1.9	Participation under other GHG Programs.....	7
1.10	Other Forms of Credit.....	7
1.11	Sustainable Development.....	7
<b>2</b>	<b>SAFEGUARDS .....</b>	<b>8</b>
2.3	AFOLU-Specific Safeguards .....	8
<b>3</b>	<b>IMPLEMENTATION STATUS .....</b>	<b>9</b>
3.1	Implementation Status of the Project Activity .....	9
3.2	Deviations .....	10
3.3	Grouped Projects .....	10
<b>4</b>	<b>DATA AND PARAMETERS.....</b>	<b>10</b>
4.1	Data and Parameters Available at Validation.....	10
4.2	Data and Parameters Monitored.....	12
4.3	Monitoring Plan.....	13
<b>5</b>	<b>QUANTIFICATION OF GHG EMISSION REDUCTIONS AND REMOVALS .....</b>	<b>15</b>
5.1	Baseline Emissions .....	15
5.2	Project Emissions .....	16
5.3	Leakage.....	16
5.4	Net GHG Emission Reductions and Removals.....	16
	<b>APPENDIX 1: CALIBRATION DETAILS .....</b>	<b>17</b>
	<b>APPENDIX 2: MAJOR BREAKDOWN DETAILS .....</b>	<b>17</b>

# 1 PROJECT DETAILS

## 1.1 Summary Description of the Implementation Status of the Project

Mytrah Energy (India) Limited (MEIL) (formerly Caparo Energy (India) Limited) is continuously developing the wind power assets in India. MEIL has set up 42 MW wind power project in Jaisalmer District in the state of Rajasthan. The project activity comprises of 20 Wind Energy Generators (WEGs) with a capacity of 2.1 MW each.

The Project activity is a zero emissions wind based power generation project connected to NEWNE regional grid of India (Now INDIAN grid). The project helps to reduce the supply demand gap in the state and also generates power using zero emissions wind based power generation which helps to reduce GHG emissions and specific pollutants like SO<sub>x</sub>, NO<sub>x</sub>, and SPM associated with the conventional thermal power generation facilities. The project activity conserves fossil fuel like coal, which can be used in other industrial applications. In the project site, there are other wind projects owned by other customers connected to the same substation. There is an apportioning procedure which is approved by the state nodal agency for apportioning the electricity to each and every customer. The WEG commissioning details has been mentioned under Section 1.7.

The total VCU's generated achieved during this monitoring period is 91,292 tCO<sub>2e</sub>.

## 1.2 Sectoral Scope and Project Type

The project activity falls under

**Sectoral Scope:** 01 - Energy industries (renewable / non-renewable sources)

**Project Type** : I - Renewable Energy Projects

**Title** : Consolidated baseline methodology for grid-connected electricity generation from renewable sources

**Reference** : Approved consolidated baseline and monitoring methodology ACM0002, Version 12.3.0<sup>2</sup>

This project is not a grouped project activity.

## 1.3 Project Proponent

<b>Organization name</b>	Mytrah Energy (India) Limited
<b>Contact person</b>	Mr. Santosh Kotti
<b>Title</b>	Assistant Manager
<b>Address</b>	1st Floor, 8001, 8th Floor, Q-City, Nanakramguda, Gachibowli Hyderabad 500032, Telangana, INDIA

<b>Telephone</b>	+91 9655967839
<b>Email</b>	<a href="mailto:santosh.kotti@mytrah.com">santosh.kotti@mytrah.com</a>

#### 1.4 Other Entities Involved in the Project

<b>Organization name</b>	<b>EKI Energy Services Limited</b>
<b>Role in the Project</b>	Project Consultant
<b>Contact person</b>	Anjali Rao
<b>Title</b>	Project Manager
<b>Address</b>	Office No. 201, EnKing Embassy, Plot No. 48, Scheme No. 78, Part II, Vijay Nagar INDORE – 452010, India.
<b>Telephone</b>	9109120940
<b>Email</b>	<a href="mailto:anjali@enkingint.org">anjali@enkingint.org</a>

#### 1.5 Project Start Date

The project start date for this project is said to be 19<sup>th</sup> June 2011. This is because the first WEG was commissioned as on the said date.

#### 1.6 Project Crediting Period

The project is registered under Clean Development Mechanism (CDM) of UNFCCC with 10 years crediting period (Reference No: 8591) on 13<sup>th</sup> Dec 2012.<sup>1</sup> Crediting period of the project under CDM starts on 31<sup>st</sup> December 2012 and ends on 30<sup>th</sup> December 2022.

The project has begun generating GHG emission reductions from 19<sup>th</sup> June 2011. Hence, crediting period for VCS begins on 19<sup>th</sup> June 2011 and ends on 18<sup>th</sup> June 2021 considering 10 years fixed crediting period.

The project proponent is also not claiming GHG emission reductions under two schemes for the same period.

#### 1.7 Project Location

The wind power project is located in Tejwa – Mokal village, Jaisalmer District, Rajasthan State, India. The geo- coordinates of the project location is as follows.

The location of WEGs is as given below

The geographical location of the project site with commissioning dates are as shown below:

<sup>1</sup> <http://cdm.unfccc.int/Projects/DB/DNV-CUK1354785555.66/view>

Sr. No.	WTG ID	WTG Co-ordinate		Date of Commissioning
		Latitude	Longitude	
1	MK014	27.1631	70.6809	04-08-2011
2	MK015	27.1612	70.6858	19-07-2011
3	MK016	27.1594	70.6907	19-07-2011
4	MK017	27.1576	70.6956	19-07-2011
5	MK021	27.1466	70.7251	30-09-2011
6	MK039	27.1697	70.6926	12-07-2011
7	MK040	27.1715	70.6877	12-07-2011
8	MK042	27.1752	70.6779	19-07-2011
9	MK043	27.1771	70.673	04-08-2011
10	MK066	27.1837	70.6848	12-07-2011
11	MK067	27.1812	70.6891	30-06-2011
12	MK068	27.1804	70.6949	30-06-2011
13	MK069	27.1782	70.6995	30-06-2011
14	MK092	27.1887	70.7016	19-06-2011
15	MK093	27.1905	70.6966	25-06-2011
16	MK094	27.1924	70.6917	30-06-2011
17	MK161	27.2195	70.6917	25-06-2011
18	MK163	27.2237	70.6833	25-06-2011
19	MK164	27.2255	70.6784	19-06-2011
20	MK165	27.2274	70.6735	19-06-2011

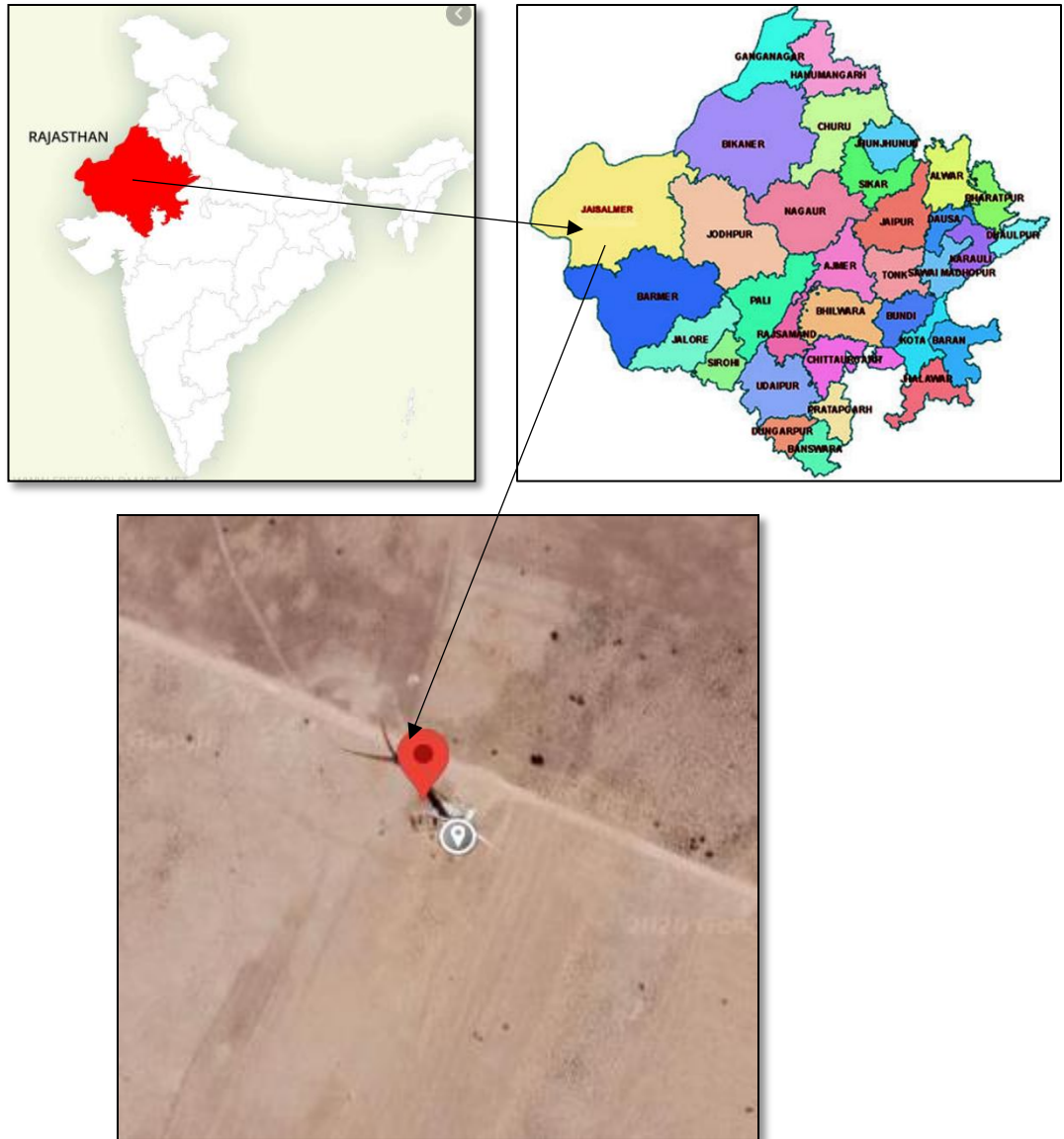

## 1.8 Title and Reference of Methodology

Title: Consolidated baseline methodology for grid-connected electricity generation from renewable sources.

Methodology applied is ACM 0002, version 12.3.0<sup>2</sup>.

“Tool to calculate the emission factor for an electricity system” version 2.2.1

<sup>2</sup> <https://cdm.unfccc.int/methodologies/DB/C505BVV9P8VSNV3LTK1BP3OR24Y5L>

## 1.9 Participation under other GHG Programs

Participation under Other GHG Programs: The PP has participated under CDM mechanism of UNFCCC. The UN reference id 8591<sup>1</sup> of program with this project activity. The PP would not consider the credit from any other mechanism for the current monitoring period which is 01-06-2018 to 05-12-2019. The undertaking is provided to confirm that there is no any double accounting for current monitoring period.

## 1.10 Other Forms of Credit

Include the following information, as applicable:

- Emission Trading Programs and Other Binding Limits: The PP has not applied this project in any Emission Trading Programs and other Binding Limits.
- Other Forms of Environmental Credit: The PP has not applied this project in any other form of environmental credits.

## 1.11 Sustainable Development

### **Contribution to sustainable development:**

Ministry of Environment and Forests, has stipulated economic, social, environment and technological well-being as the four indicators of sustainable development. The project contributes to sustainable development using the following ways.

- **Social well-being:** The project would help in generating employment opportunities during the construction and operation phases. The project activity leads to development in infrastructure in the region like development of roads and also may promote business with improved power generation.
- **Economic well-being:** The project is a clean technology investment in the region, which would not have been taken place in the absence of the VCS benefits the project activity also helps to reduce the demand supply gap in the state.  
**Technological well-being:** The successful operation of project activity would lead to promotion of solar based power generation and would encourage other entrepreneurs to participate in similar projects
- **Environmental well-being:** The project activity being a renewable source of energy, it reduces the dependence on fossil fuels and conserves natural resources which are on the verge of depletion. Due to its zero emission the project activity also helps in avoiding significant amount of GHG emissions.

## 2 SAFEGUARDS

### 2.1 No Net Harm

The project does not involve any potential negative environmental and socio economic impacts and hence this criteria is not applicable to this project activity.

### 2.2 Local Stakeholder Consultation

The stakeholders identified for the project were: the usual occupants of the villages around and the local communities, NGOs, governmental agencies, employees, contractors. Local population is considered to be a major stakeholder with respect to the project activity. Comments were received from the village people. Newspaper advertisement was placed in newspaper on 16/03/2011. The stakeholder meeting was organised at the project site on 31/03/2011.

Representative of the project proponent explained the purpose of the meeting and detailed each questions in the questionnaire. He further explained about the advantages of the wind energy generation and explained how the project would help in reducing demand supply gap in environment friendly manner.

The villagers wished to know the impact of WTGs on the environment in the region. Further to the discussion, Representative of Suzlon Energy Limited, explained it's a eco-friendly technology which have no harmful effect on the environment. Finally the comments were received from the stakeholder, which has been briefed in section E-2 of registered PDD.

According to the feedback received from the stakeholders, due to the erection of wind farms the socioeconomic situation in the area and the village people's living standard has been improved. It has not only provided employment but also significantly contributed to the infrastructure development likes roads.

Local Stakeholder consultation had been carried out during CDM registration of this project activity. There were no comments that required follow up action from PP. The PP also placed a grievance register onsite in where the stakeholder can put down his/her complain and the same if found genuine will be addressed immediately.

### 2.3 AFOLU-Specific Safeguards

This Section is not applicable here as the project activity is not an AFOLU project activity.

## 3 IMPLEMENTATION STATUS

### 3.1 Implementation Status of the Project Activity

The project activity comprises of 20 Wind Turbine Generators (WTG's) with a capacity of 2.1 MW each. The project activity is using S-95- 2.1 MW WTG manufactured by Suzlon Energy Ltd. The technology of electricity generation from renewable wind resource is environment friendly as it does not use any fossil fuel. The power (electricity) thus produced by the project activity would be transmitted to the state electricity grid, thereby displacing equivalent amount of power in the grid which is dominated by emission intensive thermal power plants.

S95-2.1 MW wind turbines utilize well-proven DFIG technology that has been deployed in more than 5000 units around the world. The technical lifetime of the wind turbine is 20 years. Key inclusions in this design are:

- DFIG convertor featuring variable speed
- Larger swept area with rotor diameters; 95 and 97 meters
- 80-meter, 90-meter and 100-meter hub heights

The technical specification of the WTG is as follows:

MODEL	S95 - 2.1MW
<b>Operating Data</b>	
Rated power	2.1MW
Cut-in wind speed	3.5 m/s
Rated wind speed	11 m/s
Cut-out wind speed	25 m/s
50 years gust wind speed	59.5 m/s
Wind Class	IEC - IIA
Rotational Speed	15 to 17.6 rpm
<b>Rotor</b>	
Pitch system	Pitch regulated, electrical
Diameter	95 m
Swept area	7085 m <sup>2</sup>
Blade material type	Epoxy bounded fibre glass
<b>Generator</b>	
Type	Asynchronous 3 phase induction with slip rings operated with rotor circuit inverter system (DFIG)
Frequency	50/60 Hz
Protection	IP 54, IP23 for slip ring unit
Cooling system	Air cooled
Insulation	Class H
Slip control	Unique Flexi-Slip providing slip up to 16.67%
<b>Braking System</b>	
Aerodynamic brake	3 independent systems with blade pitching
Mechanical brake	Hydraulic fail-safe disc brake system

Gearbox	
Type	3 stages (One planetary & Two helical)
Yaw System	
Type	Driven by 3 electrical driven planetary drives
Bearings	Polyamide slide
Tower	
Type	Tubular Steel Tower (4 sections)

No events or situations happened during the reported monitoring period that can alter the applicability of the applied methodology.

The commissioning dates respective to the WTG sites are mentioned in section 1.7.

## 3.2 Deviations

### 2.3.1 Methodology Deviations

There is no request for deviation applied during this monitoring period.

### 2.3.2 Project Description Deviations

No deviation project description deviation is applicable for the project.

## 3.3 Grouped Projects

This project activity is not a grouped project activity.

# 4 DATA AND PARAMETERS

## 4.1 Data and Parameters Available at Validation

<b>Data / Parameter</b>	<b>EF<sub>grid,OMsimple,y</sub></b>
<b>Data unit</b>	tCO <sub>2</sub> /MWh
<b>Description</b>	Operating margin CO <sub>2</sub> emission factor of NEWNE grid
<b>Source of data</b>	Central Electricity Authority:CO <sub>2</sub> Emission Database CEA CO <sub>2</sub> Baseline database Version 07 <sup>3</sup>
<b>Value applied</b>	0.9842
<b>Justification of choice of data or description of measurement methods</b>	The operating margin emission factor data has been deduced from CO <sub>2</sub> database. CEA CO <sub>2</sub> Baseline database Version 07

<sup>3</sup> [http://www.cea.nic.in/reports/planning/cdm\\_co2/cdm\\_co2.htm](http://www.cea.nic.in/reports/planning/cdm_co2/cdm_co2.htm)

and procedures applied	
Purpose of Data	Calculation of baseline emissions
Comments	<p>The operating margin emission factor is a 3-year generation-weighted average (2008-11).</p> <p>Data calculated to be 0.9842. The operating Margin is calculated ex ante and fixed during the crediting period.</p>

Data / Parameter	<b>EF<sub>grid,BM,y</sub></b>
Data unit	tCO <sub>2</sub> /MWh
Description	Build margin CO <sub>2</sub> emission factor of NEWNE grid
Source of data	Central Electricity Authority:CO <sub>2</sub> Emission Database CEA CO <sub>2</sub> Baseline database Version 07 <sup>4</sup>
Value applied	0.8588
Justification of choice of data or description of measurement methods and procedures applied	<p>The operating margin emission factor data has been deduced from CO<sub>2</sub> database.</p> <p>CEA CO<sub>2</sub> Baseline database Version 07</p>
Purpose of Data	Calculation of baseline emissions
Comments	<p>The build Margin would be calculated ex-ante and fixed during the crediting period. For ex-ante calculation the most recent data available has been used and the build margin thus calculated is 0.8588</p>

Data / Parameter	<b>EF<sub>grid,CM,y</sub></b>
Data unit	tCO <sub>2</sub> /MWh
Description	Combined margin CO <sub>2</sub> emission factor of NEWNE grid
Source of data	Central Electricity Authority:CO <sub>2</sub> Emission Database CEA CO <sub>2</sub> Baseline database Version 07 <sup>5</sup>
Value applied	0.9529
Justification of choice of data or description of measurement methods and procedures applied	<p>Calculated as per the procedures in “Tool to calculate the emission factor for an electricity system” based on CEA data.</p>
Purpose of Data	Calculation of baseline emissions

<sup>4</sup> [http://www.cea.nic.in/reports/planning/cdm\\_co2/cdm\\_co2.htm](http://www.cea.nic.in/reports/planning/cdm_co2/cdm_co2.htm)

<sup>5</sup> [http://www.cea.nic.in/reports/planning/cdm\\_co2/cdm\\_co2.htm](http://www.cea.nic.in/reports/planning/cdm_co2/cdm_co2.htm)

<b>Comments</b>	The combined margin would be calculated ex-ante and fixed for the entire crediting period and the combined margin thus calculated is 0.9529.
-----------------	--

## 4.2 Data and Parameters Monitored

<b>Data / Parameter</b>	<b>EG<sub>PJ,y</sub></b>
<b>Data unit</b>	MWh
<b>Description</b>	Quantity of net electricity exported to the grid during the year y.
<b>Source of data</b>	Certificate for share of electricity generated by Wind Farm.
<b>Description of measurement methods and procedures to be applied</b>	<p>Net electricity supplied is calculated on the basis of the difference between calculated values of “export” and calculated value “import” on the JVVNL energy meter at the common evacuation point and the percentage transmission loss as prescribed in the PPA for metering at 220 kV.</p> <p>All the data items monitored under the monitoring plan is archived for entire crediting period or till the last issuance of VER/CERs for this project activity whichever occurs later.</p> <p>Calibration Frequency: All Energy meters are tested for accuracy at least once in a year. The accuracy class of the energy meter is 0.2s</p>
<b>Frequency of monitoring/recording</b>	Measuring frequency: Continuous Reading frequency: Daily Recording frequency: Monthly
<b>Value monitored</b>	95,804.82 MWh
<b>Monitoring equipment</b>	Energy meters of 0.2s accuracy class
<b>QA/QC procedures to be applied</b>	Net electricity supplied to the grid by the project activity is cross checked with invoices submitted to JVVNL.
<b>Purpose of the data</b>	Calculation of baseline emissions
<b>Calculation method</b>	Net electricity supplied to the grid by the project activity is cross checked with invoices submitted to JVVNL.
<b>Comments</b>	The data will be archived for two years after the end of the last crediting period or till the last issuance of CERs for the project activity, whichever is later.

<b>Data / Parameter</b>	<b>E,WEG,I,Y</b>
<b>Data unit</b>	MWh/y
<b>Description</b>	Quantity of Electricity generated by the individual WEGs of the PP in year y.
<b>Source of data</b>	WEG controller meter reading
<b>Description of measurement methods and procedures to be applied</b>	<p>Electricity generated by the WEG is continuously monitored by the controller meter installed within the WEG. These reading are recorded online by the technology supplier.</p> <p>Calibration Frequency: The WEG controller meter does not require calibration as per the specification provided by the technology supplier.</p> <p>Calibration Frequency: All Energy meters are tested for accuracy at least once in a year. The accuracy class of the energy meter is 0.2s</p>
<b>Frequency of monitoring/recording</b>	Continuous measuring
<b>Value monitored</b>	105226.41 MWh (summation of generation from all 20 WEGs)
<b>Monitoring equipment</b>	Microprocessor based controller meter
<b>QA/QC procedures to be applied</b>	The quantity of electricity generated by the individual WEG is cross-checked with the online tracking system provided by the technology supplier.
<b>Purpose of the data</b>	Calculation of baseline emissions
<b>Calculation method</b>	Not Applicable
<b>Comments</b>	-

### 4.3 Monitoring Plan

The electricity exported to the grid through the project activity and the electricity imported from the JVNl grid is monitored. The electricity export and import is through a common evacuation system having common metering equipments. Suzlon Energy Limited has been identified as the common agency responsible for joint metering.

The organizational structure of this VCS project activity is as follows:

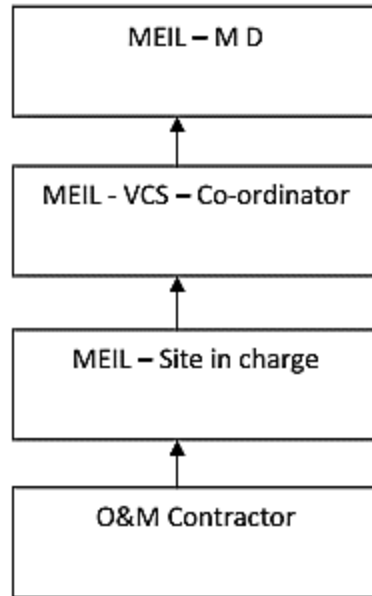

The project proponent has entered into agreement with the WEG- Supplier – Suzlon Energy Limited for the operation and maintenance of WEGs. The WEG supplier has dedicated and technically well-equipped O&M team for day to day Operation and maintenance of each WEG. O&M contractor provides a monthly report, which includes wind data, generation data, major breakdown events and machine availability, which forms the basis for invoicing and emission reduction computation. Project Manager is responsible for recording of monthly Joint Meter Readings of export and import. Monthly power export and import data are to be sent regularly to CDM coordinator of MEIL. All data will be archived for a period two years after crediting period. The single line diagram for the project activity is as follows:

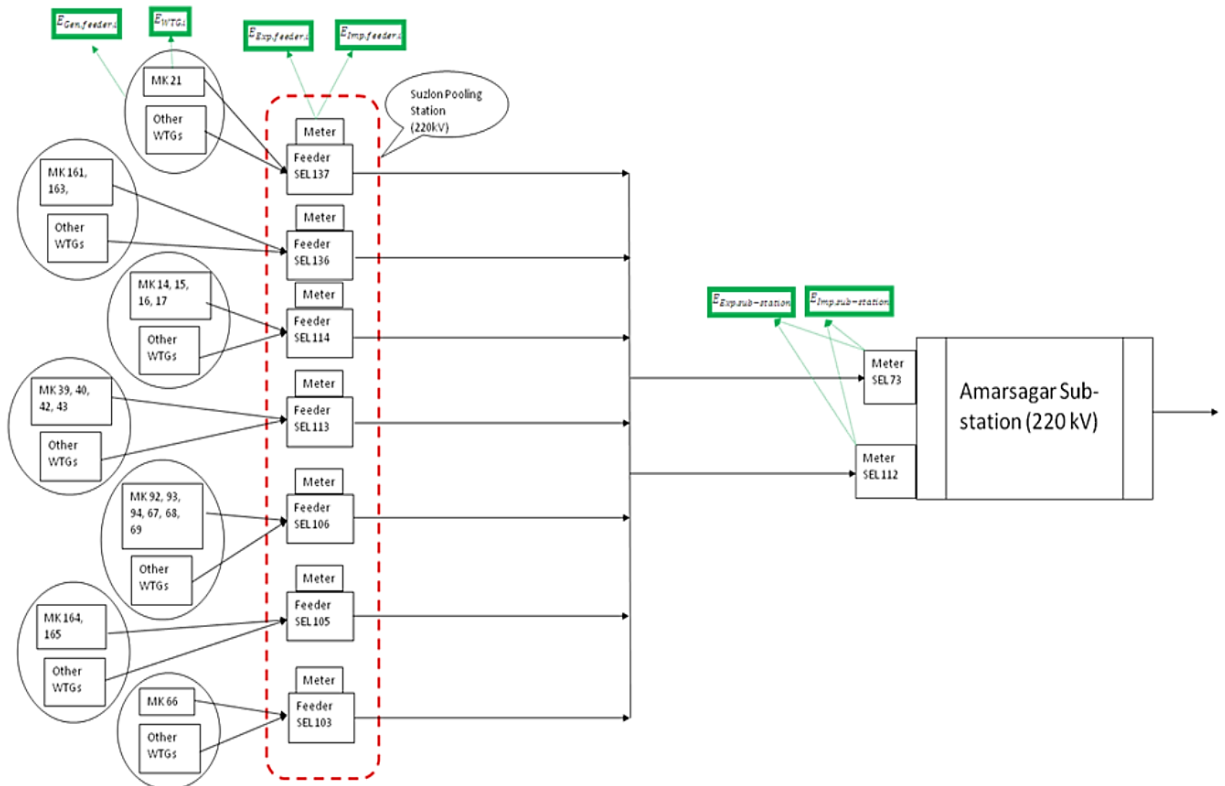

## 5 QUANTIFICATION OF GHG EMISSION REDUCTIONS AND REMOVALS

### 5.1 Baseline Emissions

The baseline emissions are the product of electrical energy baseline  $EG_{BL,y}$  expressed in MWh of electricity produced by the renewable generating unit multiplied by the grid emission factor. Baseline emission factor is calculated as combined margin, consisting of a combination of operating margin (OM) and build margin (BM) factors.

$$BE_y = EG_{BL,y} * EF_{grid, CM, y}$$

Where:

- $BE_y$  : Baseline Emissions in year  $y$ ; t CO<sub>2</sub>
- $EG_{BL,y}$  : Energy baseline in year  $y$ ; MWh
- $EF_{grid, CM, y}$  : Combined margin CO<sub>2</sub> emission factor for grid connected power generation in year  $y$ , tCO<sub>2</sub>/MWh

As per registered CDM PDD, combined margin emission factor is 0.9529 tCO<sub>2</sub> /MWh. Hence the baseline emissions for the project activity for the current monitoring period are as follows.

$$BE_y = EG_{BL, y} * EF_{CO_2} = 95,804.82 * 0.9529 = 91,292 \text{ tCO}_2\text{e (round down values)}$$

## 5.2 Project Emissions

The project activity involves in harnessing wind power. So the emissions from the project are zero.

## 5.3 Leakage

The project activity is a Greenfield wind power project and there is no technology transfer with respect to this project activity. Hence the Leakage emissions for the project are zero.

## 5.4 Net GHG Emission Reductions and Removals

Year	Baseline emissions or removals (tCO <sub>2</sub> e)	Project emissions or removals (tCO <sub>2</sub> e)	Leakage emissions (tCO <sub>2</sub> e)	Net GHG emission reductions or removals (tCO <sub>2</sub> e)
01/06/2018 to 31/12/2018	39978	0	0	39978
01/01/2019 to 05/12/2019	51314	0	0	51314
<b>Total</b>	91292	0	0	91292

The actual GHG avoided during the current monitoring plan is 91,292 tCO<sub>2</sub>e. The estimated GHG during current monitoring period is 107,083 tCO<sub>2</sub>e. The actual VER is -14.75% lower than the estimated VER. This variation is majorly due to the variations in wind flow pattern, grid availability and other parameters which are not in the control of PP. The above variations is conservative.

## APPENDIX 1: CALIBRATION DETAILS

Feeder number	Meter number	Meter make	Calibration date	Calibration due date
SEL-73	13195548	L&T	18/04/2018	17/04/2019
			23/03/2019	22/03/2020
	13195549	L&T	18/04/2018	17/04/2019
			23/03/2019	22/03/2020
SEL-112	RJB90206	L&T	18/04/2018	17/04/2019
			23/03/2019	22/03/2020
	RJB90207	L&T	18/04/2018	17/04/2019
			23/03/2019	22/03/2020

## APPENDIX 2: MAJOR BREAKDOWN DETAILS

Gen. Date	Month	Site	Loc. No.	Breakdown Remark	Formula Parameter	Breakdown Hrs.
09-Aug-2018	Aug-18	Mokal	MK068	HSS Shaft Failure	U	24.00
23-Aug-2019	Aug-18	Mokal	MK068	HSS Shaft Failure	U	24.00
11-Sep-2018	Sep-18	Mokal	MK068	HSS Shaft Failure	U	24.00
16-Sep-2018	Sep-18	Mokal	MK068	HSS Shaft Failure	U	24.00
27-Sep-2018	Sep-18	Mokal	MK068	HSS Shaft Failure	U	24.00
14-Oct-2018	Oct-18	Mokal	MK068	HSS Shaft Failure	U	24.00
20-Nov-2018	Nov-18	Mokal	MK068	HSS Shaft Failure	U	24.00
16-Dec-2018	Dec-18	Mokal	MK068	HSS Shaft Failure	U	24.00
20-Feb-2019	Feb-19	Mokal	MK068	HSS Shaft Failure	U	24.00
21-Feb-2019	Feb-19	Mokal	MK068	HSS Shaft Failure	U	24.00
19-Mar-2019	Mar-19	Mokal	MK068	HSS Shaft Failure	U	24.00
13-Jun-2019	Jun-19	Mokal	MK014	Elec FB NacelleFan Err	U	24.00
03-Jul-2019	Jul-19	Mokal	MK021	Elec FB GearBox Heating	U	24.00
13-Sep-2019	Sep-19	Mokal	MK040	Elec VibControllerErrStop	U	24.00
13-Sep-2019	Sep-19	Mokal	MK043	Elec YawSensor ErrStop	U	24.00
13-Sep-2019	Sep-19	Mokal	MK069	Elec FB YawCCW Err	U	24.00
21-Oct-2019	Oct-19	Mokal	MK093	Elec_YawMonitoringDefect	U	19.40